

TECHNICAL MANUAL

DIRECT AND GENERAL SUPPORT MAINTENANCE MANUAL

FOR

**TRUCK, TRACTOR, LINE HAUL
52,000 GVWR, 6 X 4, M915A2
(NSN 2320-01-272-5029)**

**TRUCK, TRACTOR, LIGHT EQUIPMENT
TRANSPORTER (LET)
68,000 GVWR, 6 X 6, W/WINCH, M916A1
(NSN 2320-01-272-5028)**

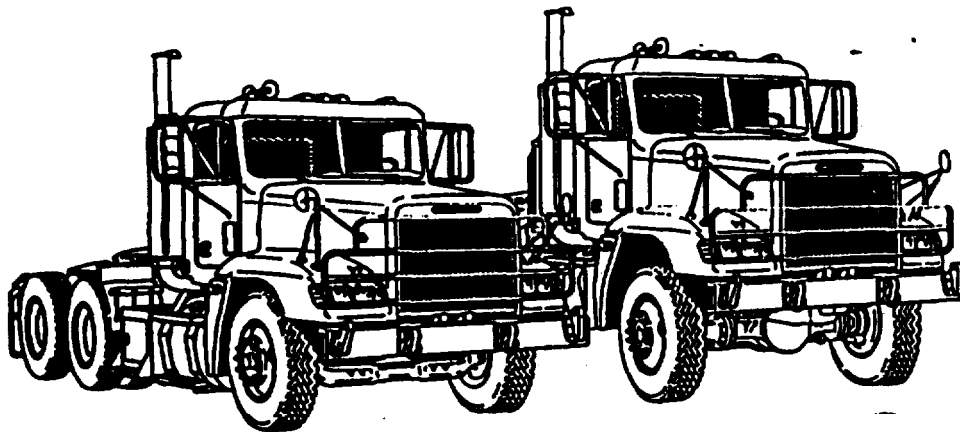

Approved for public release; distribution is unlimited.

TABLE OF CONTENTS	i
-------------------	---

HOW TO USE THIS MANUAL	v
---------------------------	---

TROUBLESHOOTING	2-2
-----------------	-----

POWER PACKAGE MAINTENANCE	3-1
------------------------------	-----

ELECTRICAL SYSTEM MAINTENANCE	4-1
----------------------------------	-----

FRONT AXLE MAINTENANCE	5-1
---------------------------	-----

REAR AXLE MAINTENANCE	6-1
--------------------------	-----

STEERING MAINTENANCE	7-1
-------------------------	-----

FRAME AND TOWING ATTACHMENTS MAINTENANCE	8-1
--	-----

SUSPENSION MAINTENANCE	9-1
---------------------------	-----

BODY, CAR, HOOD, AND HULL MAINTENANCE	10-1
--	------

WINCH MAINTENANCE	11-1
-------------------	------

INDEX	Index-1
-------	---------

WARNING**CARBON MONOXIDE POISONING CAN BE DEADLY**

CARBON MONOXIDE IS A COLORLESS, ODORLESS, DEADLY POISONOUS GAS, WHICH, WHEN BREATHED, DEPRIVES THE BODY OF OXYGEN AND CAUSES SUFFOCATION. EXPOSURE TO AIR CONTAMINATED WITH CARBON MONOXIDE PRODUCES SYMPTOMS OF HEADACHE, DIZZINESS, LOSS OF MUSCULAR CONTROL, APPARENT DROWSINESS, OR COMA. PERMANENT BRAIN DAMAGE OR DEATH CAN RESULT FROM SEVERE EXPOSURE.

CARBON MONOXIDE OCCURS IN THE EXHAUST FUMES OF FUEL-BURNING HEATERS AND INTERNAL-COMBUSTION ENGINES AND BECOMES DANGEROUSLY CONCENTRATED UNDER CONDITIONS OF INADEQUATE VENTILATION. THE FOLLOWING PRECAUTIONS MUST BE OBSERVED TO ENSURE THE SAFETY OF PERSONNEL WHENEVER THE PERSONNEL HEATER, MAIN, OR AUXILIARY ENGINE OF ANY VEHICLE IS OPERATED FOR MAINTENANCE PURPOSES OR TACTICAL USE:

1. DO NOT operate engine of vehicle in an enclosed area unless it is ADEQUATELY VENTILATED.
2. DO NOT idle engine for long periods without maintaining ADEQUATE VENTILATION in the personnel compartments.
3. DO NOT drive any vehicle with inspection plates, cover plates, or engine compartment doors removed unless necessary for maintenance purposes.
4. BE ALERT at all times during vehicle operation for exhaust odors and exposure symptoms. If either is present, IMMEDIATELY VENTILATE personnel compartments. If symptoms persist, remove affected personnel from vehicle and treat as follows: expose to fresh air; keep warm, DO NOT PERMIT EXERCISE; if necessary, administer artificial respiration (see FM 21-11),

THE BEST DEFENSE AGAINST CARBON MONOXIDE POISONING IS ADEQUATE VENTILATION.

WARNING

COMPRESSED AIR

To prevent injury, compressed air will not exceed 30 psi (207 kPa). Use only with effective chip guarding and personal protective equipment (goggles/shield, gloves, etc.).

WARNING

Drycleaning solvent P-D-680 is toxic and flammable. Wear protective goggles and gloves and use only in a well-ventilated area. Avoid contact with skin, eyes, and clothes and do not breathe vapors. Do not use near open flame or excessive heat. The flash point is 100°-138°F (38°-50°C). If you become dizzy while using cleaning solvent, get fresh air immediately and get medical aid. If contact with eyes is made, wash your eyes with water and get medical aid immediately.

WARNING

Adhesives, solvents, and sealing compounds can burn easily, can give off harmful vapors, and are harmful to skin and clothing. To avoid injury or death, keep away from open fire and use in well-ventilated area. If adhesive, solvent, or sealing compound gets on skin or clothing, wash immediately with soap and water.

WARNING

Make sure lifting device is securely fastened and weight being lifted does not exceed capacity of lifting device. Failure to do so may cause personal injury.

WARNING

Do not disconnect any air system lines or fittings unless vehicle engine is shut off and air system pressure is relieved. To do so could result in serious injury to personnel.

WARNING

Spilled hydraulic fluid is very slippery. Wipe up any spilled fluid immediately. Failure to do so could result in serious injury to personnel.

WARNING

When servicing this vehicle, performing maintenance, or disposing of materials such as engine coolant, transmission fluid, lubricants, battery acids or batteries and CARC paint, consult your Unit/Local Hazardous Waste Disposal Center or safety office for local regulatory guidance. If further information is needed, please contact the Army Environmental Hotline at 1-800-872-3845.

WARNING

Use care to prevent refrigerant from touching your skin or eyes, because liquid refrigerant, when exposed to air, quickly evaporates and will freeze skin or eye tissue. Serious injury or blindness could result if you come into contact with liquid refrigerant.

WARNING

Refrigerant R-134a air conditioning systems should not be pressure tested or leak tested with compressed air. Combustible mixtures of air and R-134a may form, resulting in a fire or explosion, which could cause personnel injury.

WARNING

Do not remove air conditioner compressor oil fill plug without first recovering the system. Failure to recover the system could cause uncontrolled release of high-pressure refrigerant, which can freeze skin and eye tissue causing serious injury or blindness.

CHANGE
NO. 2

HEADQUARTERS
DEPARTMENT OF THE ARMY
Washington, D.C., 24 February 2006

DIRECT AND GENERAL SUPPORT MAINTENANCE MANUAL

FOR

**TRUCK, TRACTOR, LINE HAUL: 52,000 GVWR, 6 X 4, M915A2
(NSN 2320-01-272-5029)**

**TRUCK TRACTOR, LIGHT EQUIPMENT TRANSPORTER (LET)
68,000 GVWR, 6 X 6, W/WINCH, M916A1
(NSN 2320-01-272-5028)**

**TRUCK TRACTOR, LIGHT EQUIPMENT TRANSPORTER (LET)
68,000 GVWR, 6 X 6, W/WINCH, M916A2
(NSN 2320-01-431-1163)**

**TRUCK, DUMP, HEAVY, CHASSIS
68,000 GVWR, 6 X 6, 14 CU YD, ON-OFF HIGHWAY
M917A1 (NSN 3805-01-431-1165)
M917A1 W/MCS (NSN 3805-01-432-8249)**

VOLUME 1 OF 2

TM 9-2320-363-34-1, dated 16 June 1992, is changed as follows:

1. The manual title is changed to read as shown above.
2. Remove old pages and insert new pages.
3. New or changed material is indicated by a vertical bar in the margin.

Remove Pages

*3-161 and 3-162
3-167 and 3-168
3-177 and 3-178
3-219 and 3-220
3-223 and 3-224
4-1 and 4-2

4-7.1 and 4-8
4-37 and 4-38
4-39 and 4-39.0
4-43 and 4-44

4-45 and 4-45.0
4-45.1 and 4-46

4-47 thru 4-47.2*

Insert Pages

*3-161 and 3-162
3-167 and 3-168
3-177 and 3-178
3-219 and 3-220
3-223 and 3-224
4-1 and 4-1.0
4-1.1 and 4-2
4-7.1 and 4-8
4-37 and 4-38
4-39 and 4-39.0
4-43 and 4-43.0
4-43.1 and 4-44
4-45 and 4-45.0
4-45.1 thru 4-45.4
4-45.5 and 4-46
4-47 thru 4-47.2*

Approved for public release; distribution is unlimited.

Remove Pages

4-47.9 and 4-47.10
11.1-17 thru 11.1-20
Index 1 thru Index 8
Back Cover Blank/Pin Number

Insert Pages

4-47.9 and 4-47.10
11.1-17 thru 11.1-20
Index 1 thru Index 8
Back Cover Blank/Pin Number

4. File this change sheet in front of the publication for reference purposes.

By Order of the Secretary of the Army:

PETER J. SCHOOMAKER
General, United States Army
Chief of Staff

Official:

SANDRA R. RILEY
Administrative Assistant to the
Secretary of the Army
0509501

DISTRIBUTION: To be distributed in accordance with the initial distribution requirements for IDN: 380905, requirements for TM 9-2320-363-34-1.

Approved for public release; distribution is unlimited.

CHANGE
NO. 1

HEADQUARTERS
DEPARTMENT OF THE ARMY
Washington D.C., 30 December 1997

DIRECT AND GENERAL SUPPORT MAINTENANCE MANUAL

FOR

**TRUCK, TRACTOR, LINE HAUL: 52,000 GVWR, 6 X 4, M915A2
(NSN 2320-01-272-5029)**

**TRUCK TRACTOR, LIGHT EQUIPMENT TRANSPORTER (LET)
68,000 GVWR, 6 X 6, W/WINCH, M916A1
(NSN 2320-01-272-5028)**

**TRUCK TRACTOR LIGHT EQUIPMENT TRANSPORTER (LET)
68,000 GVWR, 6 X 6, W/WINCH, M916A2
(NSN 2320-01-431-1163)**

**TRUCK, DUMP, HEAVY, CHASSIS
68,000 GVWR, 6 X 6, 14 CU YD, ON-OFF HIGHWAY
M917A1 (NSN 3805-01-431-1165)
M917A1 W/MCS (NSN 3805-01-432-8249)**

VOLUME 1 OF 2

Approved for Public Release; Distribution is Unlimited

TM 9-2320-363-34-1, dated 16 June 1992, is changed as follows:

1. The manual title is changed to read as shown above.
2. Remove old pages and insert new pages.
3. New or changed material is indicated by a vertical bar in the margin.

Remove Pages

i thru vi
1-7 thru 1-3/(1-4 Blank)
2-1 thru 2-4
2-7 thru 2-72
2-19 and 2-20
2-23 thru 2-26

2-33 thru 2-36
3-1 thru 3-6
3-43 thru 3-46
3-51 and 3-52
3-61 and 3-62

3-67 thru 3-70

3-79 and 3-80
3-97 and 3-92
3-113 and 3-114
3-183 and 3-184

Insert Pages

c/(d Blank)
i thru vi
1-1 thru 1-3/(1-4 Blank)
2-1 thru 2-4
2-7 thru 2-12
2-19 and 2-20
2-23 thru 2-26
2-28.7 thru 2-28.9/(2-28.10 Blank)
2-33 thru 2-36
3-1 thru 3-6
3-43 thru 3-46
3-57 and 3-52
3-61 and 3-62
3-66.1 thru 3-66.5/(3-66.6 Blank)
3-67 thru 3-70
3-70.7 thru 3-70.4
3-79 and 3-80
3-91 and 3-92
3-113 and 3-114
3-183 and 3-184

Remove Pages

3-197 and 3-198
 3-233 thru 3-236
 3-239 thru 3-246
 3-249 thru 3-256
 3-263 thru 3-270

3-273 thru 3-277/(3-278 Blank)

4-1 and 4-2
 4-7 and 4-8

4-9 thru 4-12
 4-15 and 4-76
 4-17 and 4-18

4-19 and 4-20

4-23 and 4-24
 4-31 and 4-32
 4-35 thru 4-38
 4-39 and 4-40

4-43 and 4-44
 4-45 and 4-46

4-47 and 4-48

5-1 and 5-2
 5-5 thru 5-10
 5-13 thru 5-16
 5-29 and 5-30
 5-33 and 5-34
 5-37 thru 5-40

6-1 and 6-2
 6-5 thru 6-8
 6-11 and 6-12
 6-15 and 6-16
 6-21 and 6-22

6-27 thru 6-31/(6-32 Blank)

7-1 thru 7-6
 8-1 and 8-2
 8- 19 thru 8-24
 8-37 and 8-38
 8-53 and 8-54
 8-67 and 8-68
 9-1 thru 9-6
 9-13 thru 9-22
 9-27 thru 9-32
 10-1 and 10-2
 10-35 and 10-36

Insert Pages

3-197 and 3-198
 3-233 thru 3-236
 3-239 thru 3-246
 3-249 thru 3-256
 3-263 thru 3-268
 3-269 and 3-269.0
 3-269.1 thru 3-269.4
 3-269.5 and 3-270

3-273 thru 3-277/(3-278 Blank)

4-1 and 4-2
 4-7 and 4-7.0
 4-7.1 and 4-8

4-9 thru 4-12
 4-15 and 4-16
 4-17 and 4-17.0
 4-17.1 and 4-18

4-19 and 4-19.0
 4-19.1 and 4-20

4-23 and 4-24
 4-31 and 4-32
 4-35 thru 4-38

4-39 and 4-39.0
 4-39.1 and 4-40

4-43 and 4-44
 4-45 and 4-45.0

4-45.1 and 4-46
 4-47 and 4-47.0

4-47.1 thru 4-47.10
 4-47.11 and 4-48

5-1 and 5-2
 5-5 thru 5-10
 5-13 thru 5-16
 5-29 and 5-30
 5-33 and 5-34
 5-37 thru 5-40

6-1 and 6-2
 6-5 thru 6-8
 6-11 and 6-12
 6-15 and 6-16
 6-21 and 6-22

6-27 thru 6-3 1/(6-32 Blank)

7-1 thru 7-6
 8-1 and 8-2
 8-19 thru 8-24
 8-37 and 8-38
 8-53 and 8-54
 8-67 and 8-68
 9-1 thru 9-6
 9-13 thru 9-22
 9-27 thru 9-34
 10-1 and 10-2
 10-35 and 10-36

Remove Pages

10-39 and 10-40

 10-41 and 10-42
 10-47 and 10-48
 10-75 and 10-76
 11-1 and 11-2
 11-7 thru 11-10
 11-15 and 11-16
 11-19 and 11-20
 11-25 and 11-26
 11-29 and 11-30
 11-33 and 11-34
 11-39 thru 11-42

Index- 1 thru Index- 7/(Index-8 Blank)

Insert Pages

10-39 and 10-39.0
 10-39.1 and 10-39.2
 10-39.3 and 10-40
 10-41 and 10-42
 10-47 and 10-48
 10-75 and 10-76
 11-1 and 11-2
 11-7 thru 11-10
 11-75 and 11-16
 77-19 and 11-20
 11-25 and 11-26
 11-29 and 11-30
 11-33 and 11-34
 11-39 thru 11-42
 11.1-1 thru 11.1-25/(11.1-26Blank)
 Index- 1 thru Index-8

4. File this change sheet in front of the publication for reference purposes.

By Order of the Secretary of the Army:

DENNIS J. REIMER
 General, United States Army
 Chief of Staff

Official:



JOEL B. HUDSON
 Administrative Assistant to the
 Secretary of the Army
 04432

Distribution:

To be distributed in accordance with IDN number 380905, Direct Support and General Support maintenance requirements for TM9-2320-363-34-1.

LIST OF EFFECTIVE PAGES**NOTE**

A vertical line in the outer margins of the page indicates the portion of text effected by the change. Changes to illustrations are indicated by miniature pointing hands. Change to wiring diagrams is indicated by shaded areas.

Dates of issue for original and change pages are:

Original - 16 June 1992

Change 1 - 30 December 1997

Change 2 - 24 February 2006

TOTAL NUMBER OF PAGES FOR FRONT AND REAR MATTER IS 31 AND TOTAL NUMBER OF CHAPTERS IS 10 CONSISTING OF THE FOLLOWING:

Page No.	*Change No.	Page No.	*Change No.	Page No.	*Change No.
Cover (Back Blank)	0	3-46 thru 3-51	0	3-245	0
		3-52	1	3-246	1
a to b	0	3-53 thru 3-60	0	3-247 thru 3-248	0
c/d (Blank)	1	3-61	1	3-249	1
A (B Blank)	2	3-62 thru (3-66.6 Blank)	1	3-250	0
i to v	1	3-67 thru 3-68	1	3-251	1
vi	0	3-69	0	3-252	0
1-1 thru 1-3	1	3-70 thru 3-70.4	1	3-253	1
(1-4 Blank)	0	3-71 thru 3-79	0	3-254	0
2-1 to 2-2	1	3-80	1	3-255	1
2-3	0	3-81 thru 3-90	0	3-256 thru 3-262	0
2-4	1	3-91	1	3-263 thru 3-266	1
2-5 thru 2-6	0	3-92 thru 3-113	0	3-267	0
2-7	1	3-114	1	3-268 thru 3-269	1
2-8	0	3-115 thru 3-161	0	3-269.1	0
2-9	1	3-162	2	3-269.2 thru 3-270	1
2-10	0	3-163 thru 3-166	0	3-271 thru 3-272	0
2-11	1	3-167	2	3-273 thru (3-278 Blank)	1
2-12 thru 2-18	0	3-168 thru 3-176	0	4-1 thru 4-1.1	2
2-19	1	3-177	2	4-2 thru 4-6	0
2-20 thru 2-23	0	3-178 thru 3-182	0	4-7 thru 4.7.0	1
2-24 thru 2-26	1	3-183	1	4-7.1	2
2-27 thru 2-33	0	3-184 thru 3-197	0	4-8 thru 4-9	0
2-34	1	3-198	1	4-10 thru 4-11	1
2-35	0	3-199 thru 3-219	0	4-12 thru 4-15	0
2-36	1	3-220	2	4-16 thru 4-17.1	1
3-1	0	3-221 thru 3-222	0	4-18	0
3-2	1	3-223	2	4-19 thru 4-19.1	1
3-3	0	3-224 thru 3-233	0	4-20 thru 4-23	0
3-4	1	3-234 thru 3-236	1	4-24	1
3-5	0	3-237 thru 3-238	0	4-25 thru 4-30	0
3-6	1	3-239	1	4-31	1
3-7 thru 3-42	0	3-240	0	4-32 thru 4-35	0
3-43	1	3-241	1	4-36 thru 4-37	1
3-44	0	3-242 thru 3-243	0	4-38 thru 4-39.1	2
3-45	1	3-244	1	4-40 thru 43	0

* Zero in this column indicates an original page.

A

Page No.	*Change No.	Page No.	*Change No.	Page No.	*Change No.
4-43.0 thru 4-45	2	9-18	0	Metric Conversion	0
4-45.0 thru 4-45.1	1	9-19	1	PIN Number	2
4-45.2 thru 4-47	2	9-20	0		
4-47.0 thru 4-47.1	1	9-21	1		
4-47.2	2	9-22 thru 9-27	0		
4-47.3 thru 4-47.8	1	9-28 thru 9-34	1		
4-47.9	2	10-1	1		
4-47.10 thru 4-47.11	1	10-2 thru 10-35	0		
4-48 thru (4-56 Blank)	0	10-36	1		
5-1 thru 5-2	1	10-37 thru 10-39	0		
5-3 thru 5-5	0	10-39.0 thru 10-39.3	1		
5-6 thru 5-9	1	10-40 thru 41	0		
5-10 thru 5-13	0	10-42	1		
5-14 thru 5-15	1	10-43 thru 10-46	0		
5-16 thru 5-29	0	10-47	1		
5-30	1	10-48 thru 10-74	0		
5-31 thru 5-33	0	10-75	1		
5-34	1	10-76 thru 10-94	0		
5-35 thru 5-36	0	11-1 thru 11-2	1		
5-37 thru 5-39	1	11-3 thru 11-7	0		
5-40 thru (5-62 Blank)	0	11-8 thru 11-9	1		
6-1 thru 6-2	1	11-10 thru 11-14	0		
6-3 thru 6-5	0	11-15	1		
6-6 thru 6-7	1	11-16 thru 11-18	0		
6-8 thru 6-10	0	11-19 thru 11-20	1		
6-11 thru 6-12	1	11-21 thru 11-24	0		
6-13 thru 6-14	0	11-25 thru 11-26	1		
6-15 thru 6-16	1	11-27 thru 11-28	0		
6-17 thru 6-20	0	11-29 thru 11-30	1		
6-21 thru 6-22	1	11-31 thru 11-32	0		
6-23 thru 6-26	0	11-33 thru 11-34	1		
6-27 thru (6-32 Blank)	1	11-35 thru 11-38	0		
7-1	0	11-39	1		
7-2 thru 7-4	1	11-40 thru 11-41	0		
7-5	0	11-42	1		
7-6	1	11-43 thru (11-48 Blank)	0		
8-1	1	11.1-1 thru 11.1-17	1		
8-2 thru 8-19	0	11.1-18 thru 11.1-20	2		
8-20 thru 8-24	1	11.1-21 thru (11.1-26 Blank)	1		
8-25 thru 8-36	0	Index-1	2		
8-37	1	Index -2	1		
8-38 thru 8-53	0	Index-3	2		
8-54	1	Index-4 thru Index-5	1		
8-55 thru 8-66	0	Index-6	2		
8-67	1	Index-7	1		
8-68 thru 8-74	0	Index-8	2		
9-1	1	Auth. Page (Back Blank)	0		
9-2	0	Sample 2028-2	0		
9-3 thru 9-5	1	2028-2	0		
9-6 thru 9-13	0	2028-2	0		
9-14 thru 9-17	1	2028-2	0		

DIRECT AND GENERAL SUPPORT MAINTENANCE MANUAL
FOR
TRUCK, TRACTOR, LINE HAUL: 52,000 GVWR, 6 X 4, M915A2
(NSN 2320-01-272-5029)
TRUCK TRACTOR, LIGHT EQUIPMENT TRANSPORTER (LET)
68,000 GVWR, 6 X 6, W/WINCH, M916A1
(NSN 2320-01-272-5028)
TRUCK TRACTOR, LIGHT EQUIPMENT TRANSPORTER (LET)
68,000 GVWR, 6 X 6, W/WINCH, M916A2
(NSN 2320-01-431-1163)
TRUCK, DUMP, HEAVY, CHASSIS
68,000 GVWR, 6 X 6, 14 CU YD, ON-OFF HIGHWAY
M917A1 (NSN 3805-01-431-1165)
M917A1 W/MCS (NSN 3805-01-432-8249)
VOLUME 1 OF 2

REPORTING ERRORS AND RECOMMENDING IMPROVEMENTS

You can help improve this manual. If you find any mistakes or if you know of a way to improve the procedures, please let us know. Mail your letter, DA Form 2028 (Recommended Changes to Publications and Blank Forms), or DA Form 2028-2 located at the back of this manual direct to: Commander, US Army Tank-automotive and Armaments Command, ATTN: AMSTA-AC-NML, Rock Island, IL 61299-7630. A reply will be furnished to you. You may also provide DA Form 2028-2 information to TACOM via datafax or e-mail. TACOM's datafax number for AMSTA-AC-NML is DSN 793-0726 or Commercial (309) 782-0726 and the e-mail address is: amsta-ac-nml@ria-emh2.army.mil.

TABLE OF CONTENTS

	Page
VOLUME 1	
CHAPTER 1 INTRODUCTION	
Section I General Information	1-1
Section II Equipment Description and Data	1-3
Section III Principles of Operation	1-3
CHAPTER 2 DIRECT AND GENERAL SUPPORT MAINTENANCE INSTRUCTIONS	
Section I Repair Parts, Special Tools; Test, Measurement, and Diagnostic Equipment (TMDE); and Support Equipment	2-1
Section II Troubleshooting	2-2

Approved for public release; distribution is unlimited.

TABLE OF CONTENTS (Cont)

	Page
Section III	General Maintenance Instructions 2-29
CHAPTER 3	POWER PACKAGE MAINTENANCE 3-1
Section I	Engine Assembly and Related Parts Removal and Installation 3-2
Section II	Transmission and Transfer Case Removal and Installation 3-234
CHAPTER 4	ELECTRICAL SYSTEM MAINTENANCE 4-1
CHAPTER 5	FRONT AXLE MAINTENANCE 5-1
CHAPTER 6	REAR AXLE MAINTENANCE 6-1
CHAPTER 7	STEERING MAINTENANCE 7-1
CHAPTER 8	FRAME AND TOWING ATTACHMENTS MAINTENANCE 8-1
CHAPTER 9	SUSPENSION MAINTENANCE 9-1
CHAPTER 10	BODY, CAB, HOOD, AND HULL MAINTENANCE 10-1
CHAPTER 11	WINCH MAINTENANCE 11-1
CHAPTER 11.1	AIR CONDITIONING SYSTEM MAINTENANCE 11.1-1
VOLUME 2	
CHAPTER 12	ENGINE, FUEL, AND COOLING SYSTEM REPAIR INSTRUCTIONS 12-1
Section I	Engine Repair 12-2
Section II	Fuel System Repair 12-170
Section III	Air Intake Repair 12-171
Section IV	Cooling System Repair 12-185
CHAPTER 13	ELECTRICAL SYSTEM REPAIR INSTRUCTIONS 13-1
Section I	Alternator Repair 13-2
Section II	Starter Repair 13-26
CHAPTER 14	TRANSMISSION REPAIR INSTRUCTIONS 14-1
Section I	Transmission Installation/Removal from Transmission Stand 14-2
Section II	Flywheel and Turbine Replacement and Repair 14-7
Section III	Torque Converter Stator Replacement and Repair 14-22
Section IV	Torque Converter Pump Replacement and Repair 14-27
Section V	Torque Converter Housing and Front Support Replacement and Repair 14-35
Section VI	Forward Clutch and Housing Replacement and Repair 14-54
Section VII	Lockup Cutoff Control Valve Repair 14-71
Section VIII	Control Valve Replacement and Repair 14-74
Section IX	Fourth Clutch Replacement and Repair 14-96

TABLE OF CONTENTS (Cont)

	Page
Section X	Third Clutch and Housing Replacement and Repair 14-105
Section XI	Gear Unit and Main Shaft Replacement and Repair 14-116
Section XII	Rear Cover and First Clutch Replacement and Repair 14-133
Section XIII	Transmission Housing Repair 14-146
Section XIV	Second Clutch Replacement and Repair 14-152
CHAPTER 15	TRANSFER CASE REPAIR INSTRUCTIONS 15-1
Section I	Transfer Case Repair (All Except M915A2) 15-2
Section II	Input Shaft Repair (All Except M915A2) 15-23
Section III	Center Shaft Repair (All Except M915A2) 15-29
Section IV	Lower Rear Output Shaft Repair (All Except M915A2) 15-33
Section V	Lower Front Output Shaft Repair (All Except M915A2) 15-37
Section VI	Lower Shift Rod Repair (All Except M915A2) 15-41
Section VII	Upper Shift Rod Repair (All Except M915A2) 15-44
Section VIII	Lubrication Pump Repair (All Except M915A2) 15-46
Section IX	Air Shift Chamber Repair (All Except M915A2) 15-51
CHAPTER 16	FRONT AXLE REPAIR INSTRUCTIONS 16-1
CHAPTER 17	FORWARD-REAR AND REAR-REAR AXLE REPAIR INSTRUCTIONS 17-1
Section I	Forward-Rear Axle Differential Carrier Repair 17-2
Section II	Rear-Rear Axle Differential Carrier Repair 17-47
Section III	Rear Axle Housing Repair 17-72
CHAPTER 18	BRAKE SYSTEM AND WHEELS REPAIR INSTRUCTIONS 18-1
CHAPTER 19	STEERING REPAIR INSTRUCTIONS 19-1
Section I	Power Steering Pump Repair 19-2
Section II	Steering Gear Repair 19-8
CHAPTER 20	FRAME AND TOWING ATTACHMENTS REPAIR INSTRUCTIONS 20-1
Section I	Fifth Wheel Replacement 20-2
Section II	Slide Bracket and Plate Repair (M915A2) 20-8
Section III	Top Plate Replacement (M915A2) 20-12
Section IV	Top Plate' Repair (M915A2) 20-15
Section V	Slide Bracket and Base Repair (M916A1 and M916A2) 20-20
Section VI	Top Plate Replacement (M916A1 and M916A2) 20-30

TABLE OF CONTENTS (Cont)

	Page
Section VII	Top Plate Repair (M916A1 and M916A2) 20-33
Section VIII	Ramp Replacement 20-38
Section IX	Frame Alinement 20-40
CHAPTER 21	SUSPENSION REPAIR INSTRUCTIONS 21-1
CHAPTER 22	BODY, CAB, HOOD, AND HULL REPAIR INSTRUCTIONS 22-1
Section I	Hood Repair.. 22-2
Section II	Hood SMC Repair 22-4
Section III	Cab Body Repair 22-12
Section IV	Cab Door Repair 22-28
CHAPTER 23	HYDRAULIC WINCH REPAIR INSTRUCTIONS 23-1
Section I	Hydraulic Winch Repair (M916A1 and M916A2) 23-2
Section II	Hydraulic Motor Repair (M916A1 and M916A2) 23-9
Section III	Hydraulic Pump Repair (M916A1 and M916A2) 23-12
Section IV	Speed Control Valve Repair (M916A1 and M916A2) 23-18
Section V	Direction Control Valve Repair (M916A1 and M916A2) 23-22
Section VI	Gear End Repair (M916A1 and M916A2) 23-26
Section VII	Motor End Repair (M916A1 and M916A2) 23-34
CHAPTER 24	POWER TAKE-OFF (PTO) REPAIR INSTRUCTIONS 24-1
CHAPTER 25	ACCESSORY ITEMS REPAIR INSTRUCTIONS 25-1
Section I	Vehicle Heater Repair (M915A2 and M916A1) 25-2
Section II	Arctic Personnel Heater Repair 25-10
Section III	Vehicle Heater/Air Conditioner Unit Repair (All Except M915A2 and M916A1) 25-36
CHAPTER 26	AIR CONDITIONING SYSTEM REPAIR INSTRUCTIONS 26-1
APPENDIX A	References A-1
APPENDIX B	Expendable Supplies and Materials List B-1
APPENDIX C	Illustrated List of Manufactured Items C-1
APPENDIX D	Torque Limits D-1
	INDEX Index 1

HOW TO USE THIS MANUAL

This manual has an edge index that will help you find specific information in a hurry. Simply spread the pages in the right edge of the manual until the printed blocks can be seen. Open the manual where the block on the edge of the page lines up with your selected topic printed in the front cover block.

OVERVIEW

This manual is organized by chapters, sections and appendices. A summary of the organization of this manual, by major divisions, follows:

Front cover index gives you a quick reference to chapters, sections, and appendices that you will use often.

WARNINGS - All warnings you should observe while working on or around the M915 family of vehicles are shown in this part of the manual. These are repeated in the parts of the manual where they apply.

Table of Contents - The contents of the chapters and appendices are listed here.

Chapter 1 - This chapter contains general information about the M915 family of vehicles.

Chapter 2 - This chapter outlines troubleshooting of the M915 family of vehicles, and their systems. It includes a troubleshooting index, by symptom and system, for troubleshooting. Other sections include information on tools, repair parts, and general maintenance instructions.

Chapters 3 thru 26 - These chapters contain step-by-step instructions for doing the maintenance tasks. Each system of the M915 family of vehicles has its own chapter, and any special tools, equipment, or supplies you may need for a task are listed.

Appendix A - This appendix lists the technical manuals and other publications you may have to refer to while working on the vehicle.

Appendix B - This appendix lists the expendable supplies and materials you will need while performing maintenance on the M915 family of vehicles.

Appendix C - This appendix describes any manufactured items you will need for performing maintenance on the M915 family of vehicles.

Appendix D - This appendix describes the proper method of tightening fasteners.

Index - The index is an alphabetical listing of the contents of this manual.

Back Cover - This inside back cover contains a metric conversion table.

USING THE MANUAL ON THE JOB

Find the task or component that needs repair by using the Index (page Index-I), then turn to the page listed for that task or component.

Read the INITIAL SETUP procedures, and gather the necessary items and personnel. Pay attention to the warnings. The INITIAL SETUP sheet is described on page vi.

1 → **TOP PLATE REPAIR**

2 → This task covers: a. Disassembly b. Cleaning c. Inspection d. Assembly

INITIAL SETUP

3 → **Applicable Configuration:**
M915A2

4 → **Tools and Special Equipment:**
Shop Equipment, SC 4910-95-CL-A31
Tool Kit, SC 5180-90-CL-N05
Shop Equipment, SC 5180-95-CL-A62
Shop Equipment, SC 4910-95-CL-A63
Plug, TF-0237

5 → **Materials/Parts:**

Kit	P/N RK-63503
Kit	P/N RK-63506
Compound, Antiseize	Appendix B, Item 11

6 → **Personnel Required:** (2)

7 → **References:**
LO 9-2320-363-12
TM 9-2320-363-20
TM 9-237

Equipment Condition: ← 8

Reference	Condition Description
Page 20-12	Top Plate Removed

General Safety Instructions: ← 9

WARNING

- When removing spring, compress spring slightly and relieve tension slowly. Failure to do so could cause spring to fly off, resulting in injury to personnel.
- Locks must be closed while adjusting to make sure contact is made with locks, yoke, and top plate. Failure to do so will result in loss of trailer.

1. TITLE—This is the name of the task.
2. TASK COVERS—This lists all the tasks included in the module.
3. APPLICABLE CONFIGURATION—If the task is applicable to only one of the vehicles, M915A2 or M916A1 (as appropriate) will be listed here.
4. TOOLS AND SPECIAL EQUIPMENT—These are the tools and equipment you will need to do the task.
5. MATERIALS/PARTS—These are the supplies you will need to do the task. If parts or materials are required, they are listed here or referenced to Appendix B.
6. PERSONNEL REQUIRED—Personnel required to perform a task will be identified if the task requires more than one.
7. REFERENCES—These are the other technical publications you will need to do the task.
8. EQUIPMENT CONDITION—This is the condition(s) the vehicle must be in before you start the task. Other tasks that must be done first are listed by page number or by technical manual number if another manual is required.
9. GENERAL SAFETY INSTRUCTIONS—These are the safety precautions that must be observed while you are doing the task.
10. FOLLOW-ON MAINTENANCE—These are the tasks listed at the end of the procedure that must be completed to return the vehicle to an operational condition.

CHAPTER 1 INTRODUCTION

Section I. GENERAL INFORMATION

SCOPE

Type of Manual: Direct and General Support Maintenance Manual.

Model Numbers and Equipment Names:

1. Truck, Tractor, Line Haul: 52,000 GVWR, 6 x 4, M915A2.
2. Truck, Tractor, Light Equipment Transporter (LET): 68,000 GVWR, 6 x 6, w/Winch, M916A1 and M916A2.
3. Truck, Dump, Heavy, Chassis: 6 x 6, M917A1 and M917A1 w/MCS.

Purpose of Equipment: The M915A2 truck tractor is a 6 x 4 prime mover of the M871, M872, and M1062 semitrailers used primarily to transport containers, bulk cargo, and petroleum products over primary and secondary roads under worldwide climatic conditions in a military environment.

The M916A1 and M916A2 truck tractors are 6 x 6 prime movers of low-bed M172 and M870 semitrailers, used primarily to transport heavy engineering equipment over primary and secondary roads, and off-roads, under worldwide climatic conditions in a military environment.

The M917A1 and M917A1 w/MCS dump trucks are 6 x 6 vehicles used to transport, dump or spread aggregate, hot mix asphalt and similar materials over primary and secondary roads and off-road.

MAINTENANCE FORMS, RECORDS, AND REPORTS

Department of the Army forms and procedures used for equipment maintenance will be those prescribed by DA Pam 738-750, The Army Maintenance Management System (TAMMS).

DESTRUCTION OF ARMY MATERIEL TO PREVENT ENEMY USE

When the tactical situation requires that Army materiel be abandoned, refer to TM 750-244-6, Procedures for Destruction of Tank-Automotive Equipment to Prevent Enemy Use, for procedures on destruction of the vehicle.

PREPARATION FOR STORAGE OR SHIPMENT

Instructions for storage and shipment, including administrative storage, are found in TM 740-90-1 and MIL-V-62038D.

REPORTING EQUIPMENT IMPROVEMENT RECOMMENDATIONS (EIRs)

If your vehicle needs improvement, let us know. Send us a Quality Deficiency Report. You the user, are the only one who can tell us what you don't like about your equipment. Let us know why you don't like the design or performance. Put it on an SF 368 (QDR) and mail it to:

COMMANDER
U.S. Army Tank-automotive and Armaments Command
A-t-TN: AMSTA-AC-NML
Rock Island, IL 61299-7630

WARRANTY INFORMATION

The vehicles are warranted by Freightliner Corporation in accordance with TB 9-2320-363-15. Warranty starts on the date found in block 23, DA Form 2408-9 in the logbook. Report all defects in material or workmanship to your supervisor, who will take appropriate action through your direct and general support maintenance shop.

METRIC SYSTEM

The equipment described herein contains metric components and requires metric common and special tools; therefore, metric units in addition to English units will be used throughout the manual. An English-to-metric conversion table is included as the last page of this manual inside the back cover.

Section II. EQUIPMENT DESCRIPTION AND DATA

DESCRIPTION

This section contains information that can be useful when performing direct and general support maintenance tasks on the M915 family of vehicles. For equipment operating data, refer to TM 9-2320-363-10.

EQUIPMENT CHARACTERISTICS, CAPABILITIES, AND FEATURES

Refer to TM 9-2320-363-10 and TM 9-2320-363-20 for equipment characteristics, capabilities, and features.

LOCATION AND DESCRIPTION OF COMPONENTS

Refer to TM 9-2320-363-10 and TM 9-2320-363-20 for location and description of components.

DIFFERENCES BETWEEN MODELS

Refer to TM 9-2320-363-10 and TM 9-2320-363-20 for differences between models.

Section III. PRINCIPLES OF OPERATION

PRINCIPLES OF OPERATION

Refer to TM 9-2320-363-10 and TM 9-2320-363-20 for principles of operation.

CHAPTER 2
DIRECT AND GENERAL SUPPORT MAINTENANCE INSTRUCTIONS

SCOPE

This chapter contains information for troubleshooting the M915 family of vehicles, as well as general maintenance instructions.

	Page
Section I. Repair Parts, Special Tools; Test, Measurement, and Diagnostic Equipment (TMDE); and Support Equipment	2-1
Section II. Troubleshooting	2-2
Section III. General Maintenance Instructions	2-29

Section I. REPAIR PARTS, SPECIAL TOOLS; TEST, MEASUREMENT, AND DIAGNOSTIC EQUIPMENT (TMDE); AND SUPPORT EQUIPMENT

OVERVIEW

This section includes information on tools and equipment you need to support the M915 family of vehicles.

COMMON TOOLS AND EQUIPMENT

For authorized common tools and equipment, refer to the Modified Table of Organization and Equipment (MTOE) applicable to your unit. Tool kits required for each task in this manual are listed on the INITIAL SETUP page for each task.

SPECIAL TOOLS, TMDE, AND SUPPORT EQUIPMENT

Special tools and support equipment required to maintain the M915 family of vehicles, are listed in the Maintenance Allocation Chart (TM 9-2320-363-20) and in the Repair Parts and Special Tools List (TM 9-2320-363-24P).

REPAIR PARTS

Repair parts are listed and illustrated in the Repair Parts and Special Tools List (TM 9-2320-363-24P).

Section II. TROUBLESHOOTING

OVERVIEW

This section contains troubleshooting, testing, and repair information for the M915 family of vehicles. Make sure the problems are real. Be sure the electrical or hydraulic power is on when needed. Refer to the preliminary troubleshooting procedures before you start troubleshooting, and during troubleshooting when referenced.

	Page
Preliminary Troubleshooting Procedures	2-2
Relieving Hydraulic System Pressure (M916A1 and M916A2)	2-2
Transmission Stall Test	2-3
Troubleshooting Symptom Index	2-4
Troubleshooting Table	2-6
Troubleshooting and Testing the Air Conditioning System (All Except M915A2 and M916A1)	2-28.1

PRELIMINARY TROUBLESHOOTING PROCEDURES

NOTE

Fluid leaks are classified as Class I, Class II, or Class III.

Class I: Seepage of fluid, as indicated by wetness or discoloration, not great enough to form drops.

Class II: Leakage of fluid great enough to form drops, but not enough to cause drops to drip from the item being checked or observed.

Class III: Leakage of fluid great enough to form drops that fall from the item being checked or observed.

Before starting any specific troubleshooting procedures, perform the following procedures:

1. Visually check for ruptured oil hoses or tubes, and for Class II or Class III leaks.
2. Check for mechanical jamming or binding caused by rocks or other foreign matter.
3. Check fluid levels in subject area and service as required (Unit PMCS, TM 9-2320-363-20-1).

RELIEVING HYDRAULIC SYSTEM PRESSURE (M916A1 and M916A2)

Cycle hydraulic winch controls a few times to drain and relieve system pressure.

TRANSMISSION STALL TEST

NOTE

To make thorough test of vehicle-mounted transmission, be sure that engine is properly tuned and that oil level in transmission is correct.

Perform transmission stall test when power package (engine and transmission) is not performing satisfactorily. Purpose Of test is to determine if transmission or engine is defective.

WARNING

Apply parking brake when performing transmission stall test. Block wheels to prevent forward or reverse movement. In event of brake failure and/or Improper blocking of wheels, vehicle can suddenly move forward or backward and could cause personal injury or death.

1. Block wheels to prevent forward or reverse movement.
2. Start engine and set parking brake.
3. Put transfer case in high range and set transmission to 2nd gear.

CAUTION

Do not maintain stall condition longer than 30 seconds. Transmission oil can become overheated and damage to transmission could occur. Do not allow temperature to exceed 300°F (140°C). Keep close check to prevent cooling system from overheating.

4. Accelerate engine to full throttle. Write down maximum rpm that engine will run (torque converter stall speed). Stall speed should be 2100 rpm ±150 rpm.
 - If engine speed is high, go to Transmission Malfunction 10.
 - If engine speed is low, go to Transmission Malfunction 11.

Troubleshooting Symptom Index

Malfunction Number	Malfunction	Troubleshooting Procedure Page
ENGINE		
1.	ENGINE FAILS TO CRANK	2-5
2.	ENGINE CRANKS BUT FAILS TO START	2-5
3.	ENGINE RUNS ERRATICALLY	2-6
4.	ENGINE OVERHEATS	2-6
5.	ENGINE RETARDER (JAKE BRAKE) NOT OPERATING	2-6

Troubleshooting Symptom Index (Cont)

Malfunction Number	Malfunction	Troubleshooting Procedure Page
-----------------------	-------------	--------------------------------------

TRANSMISSION

1.	TRANSMISSION OIL TEMPERATURE GAGE STAYS OVER 251°F (121°C)	2-7,
2.	TRANSMISSION NOISY	2-9
3.	TRANSMISSION WILL NOT SHIFT INTO GEAR, SLIPS OUT OF GEAR, OR OPERATES ERRATICALLY	2-11
4.	OIL LEAKING AT CONVERTER HOUSING	2-13
5.	EXCESSIVE CREEP IN FIRST AND REVERSE	2-13
6.	AUTOMATIC SHIFTS OCCUR AT TOO HIGH A SPEED	2-14
7.	AUTOMATIC SHIFTS OCCUR AT TOO LOW A SPEED, OR SHIFTS ROUGH	2-15
8.	VEHICLE MOVES IN NEUTRAL.	2-17
9.	TRANSMISSION SLIPS IN ALL FORWARD GEARS	2-17
10.	HIGH STALL SPEED (ABOVE 1200 RPM)	2-18
11.	LOW STALL SPEED (BELOW 1100 RPM)	2-18

■ TRANSFER CASE (ALL EXCEPT M915A2)

1.	TRANSFER CASE WILL NOT ENGAGE, SHIFT CONTROL CABLE AND LINKAGE IS OPERATIVE	2-19
2.	TRANSFER CASE WILL NOT ENGAGE IN HIGH RANGE, LOW RANGE IS OPERATIVE, SHIFT CONTROL CABLE AND LINKAGE IS OPERATING	2-19
3.	TRANSFER CASE WILL NOT ENGAGE IN LOW RANGE, HIGH RANGE IS OPERATIVE, SHIFT CONTROL CABLE AND LINKAGE IS OPERATING	2-19
4.	TRANSFER CASE OVERHEATS DURING OPERATION, LUBRICATION AT PROPER LEVEL.	2-19
5.	TRANSFER CASE EXCESSIVELY NOISY	2-19

STEERING

1.	ABNORMAL NOISE	2-20
2.	NO RECOVERY	2-20
3.	EXTERNAL OIL LEAKS FROM STEERING GEAR	2-23
4.	OVERSTEER OR DARTING	2-23
5.	HIGH STEERING EFFORT IN ONE DIRECTION	2-23
6.	HIGH STEERING EFFORT IN BOTH DIRECTIONS	2-24

■ HYDRAULIC WINCH (M916A1 AND M916A2)

1.	NO OR LOW OIL FLOW FROM PUMP	2-24
2.	EXTERNAL LEAKS	2-24
3.	DELIVERS LESS THAN OR NO RATED PULL	2-25
4.	DOES NOT HOLD LINE IN NEUTRAL.	2-25
5.	BRAKE WILL NOT RELEASE	2-25
6.	BRAKE WILL NOT APPLY, OR APPLIES BUT TORQUE LOW	2-26

Troubleshooting Symptom Index (Cont)

Malfunction Number	Malfunction	Troubleshooting Procedure Page
ARCTIC HEATER		
1.	HEATER WILL NOT START, BLOWER DOES NOT RUN	2-26
2.	BLOWER RUNS WHEN SWITCH IS IN START POSITION, BUT HEATER WILL NOT IGNITE	2-26
3.	BLOWER RUNS WHEN SWITCH IS IN START POSITION AND HEATER IGNITES, BUT PILOT LAMP WILL NOT LIGHT	2-27
4.	HEATER STARTS AND RUNS BUT GOES OUT LATER	2-27
5.	HEATER OVERHEATS	2-27
6.	HEAT OUTPUT LOW	2-27
7.	HEATER BURNS ON HIGH HEAT CONTINUOUSLY	2-28
8.	HEATER BURNS ON LOW HEAT CONTINUOUSLY.	2-28
9.	HEATER SMOKES EXCESSIVELY	2-28
10.	BLOWER WILL NOT STOP WHEN HEATER IS SHUT OFF.	2-28

Table 2-1. Troubleshooting

Malfunction	Test or Inspection	Corrective Action
ENGINE		
1. ENGINE FAILS TO CRANK.	Using accessory drive, rotate engine two complete revolutions.	<ul style="list-style-type: none"> • If engine cannot be rotated, internal damage is indicated and engine must be disassembled to determine damage (page 3-2).
2. ENGINE CRANKS BUT FAILS TO START.	<p>Step 1. Inspect timing wheel for looseness.</p> <ul style="list-style-type: none"> • Tighten timing wheel (page 12-41). <p>Step 2. Inspect timing wheel for chipped or missing teeth.</p> <ul style="list-style-type: none"> • Replace timing wheel (page 12-41). <p>Step 3. Check injector drive pulses. With ignition off, remove rocker arm cover (page 3-71). Disconnect return wire 619 or 620 and install 6-volt test light in place of disconnected wire and ground. Crank engine and observe that plunger motion coincides with light flashes. Reconnect return wire and repeat step for remaining cylinders.</p> <p style="padding-left: 40px;"> If light does not flash for one or more tests, troubleshoot DDEC (TM 9-2320-363-20). If light and start of plunger motion do not coincide, check mechanical timing (page 3-178).</p>	

Table 2-1. Troubleshooting (Cont)

Malfunction	Test or Inspection	Corrective Action
-------------	--------------------	-------------------

ENGINE (CONT)

3. ENGINE RUNS ERRATICALLY.

- Step 1. Inspect timing wheel for looseness.
- Tighten timing wheel (page 12-41).
- Step 2. Inspect timing wheel for chipped or missing teeth.
- Replace timing wheel (page 12-41).

4. ENGINE OVERHEATS.

- Step 1. Check for excessive fan tip movement (wobble). Measure movement with fan disengaged. Movement must not exceed 3/16 in. (4.76 mm) fore and aft at blade tip.
- If measurement exceeds 3/16 in. (4.76 mm), replace clutch (TM 9-2320-363-20). If measurement is within tolerance, go to step 2.

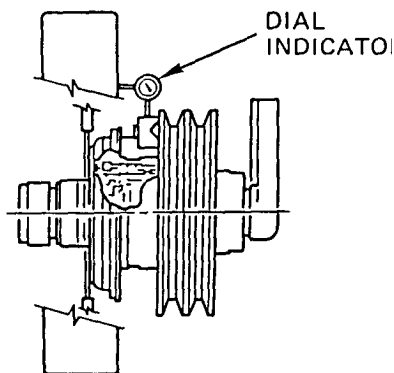

- Step 2. Check for lining wear. Install dial indicator as close to clutch as possible and place indicator probe on clutch. Apply air pressure of at least 90 psi (620.5 kPa). Make sure fan rotates freely. Zero indicator and release pressure and disconnect tube.
- If dial indicator reads 0.17 in. (4.32 mm) or greater, repair (page 12-206) or replace clutch (TM 9-2320-363-20).

5. ENGINE RETARDER (JAKE BRAKE) NOT OPERATING.

- Test retarder solenoid (page 4-50).
- Replace retarder solenoid (page 4-50).

Table 2-1. Troubleshooting (Cont)

Malfunction	Test or Inspection	Corrective Action
-------------	--------------------	-------------------

NOTE

To make a thorough test of vehicle-mounted transmission, be sure engine is properly tuned and oil level in transmission is correct.

TRANSMISSION

1. TRANSMISSION OIL TEMPERATURE GAGE STAYS OVER 250°F (121°C).

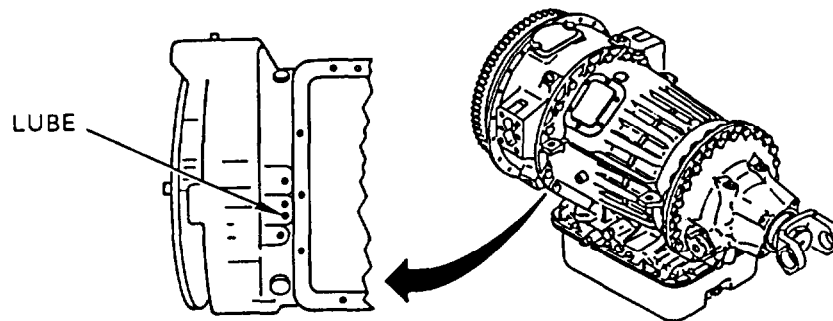

Step 1. Check for low lubrication oil pressure. Remove plug from lube port and install 0 to 100 psi (0 to 690 kPa) gage. Start engine and allow to run at idle speed. With parking brake applied, shift transmission into DRIVE and accelerate engine to approximately 1900 rpm. Check for 25 to 30 psi (172 to 207 kPa) lube system pressure.

- If pressure is less than 25 or more than 30 psi (172 to 207 kPa), disassemble transmission (pages 14-22, 14-27, 14-35) and check for damaged torque converter.

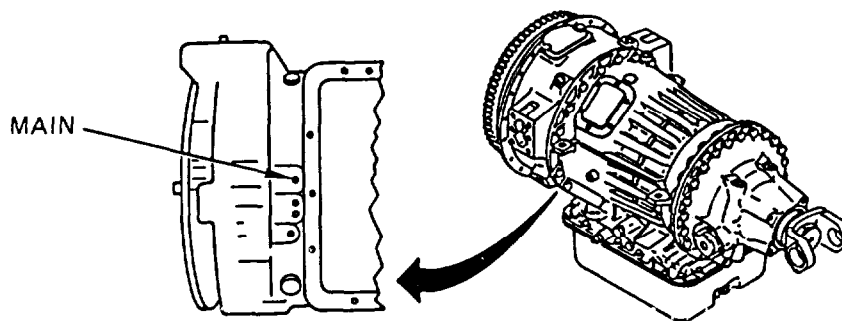

Step 2. Check for low main pressure. Remove oil line (all except M915A2) or plug (M915A2) from main pressure port on transmission and install tee (all except M915A2) and 0 to 300 psi (0 to 2070 kPa) gage. Start engine and allow to run at idle speed (600 rpm). With parking brake applied, shift transmission into DRIVE. Check for 80 to 100 psi (552 to 690 kPa) main system pressure.

- If pressure is not 80 to 100 psi (552 to 690 kPa), disassemble transmission (page 14-27) and inspect lubrication pressure regulator and converter bypass valve for damage.

Table 2-1. Troubleshooting (Cont)

Malfunction	Test or Inspection	Corrective Action
-------------	--------------------	-------------------

TRANSMISSION (CONT)

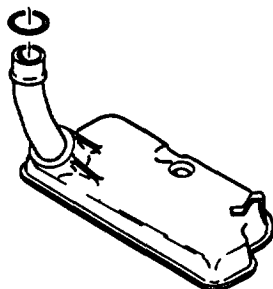

Step 3. Check for clogged internal filter element. Remove internal filter element (page 3-258).

- If internal filter element is clogged, replace internal filter element (page 3-258) and repeat step 2.

Step 4. Check for damaged or missing preformed packing on internal filter pickup tube.

- If preformed packing is damaged or missing, replace preformed packing (page 3-258) and repeat step 2.
- If preformed packing is not damaged or missing, disassemble transmission (page 14-1) and inspect oil pump, main pressure regulator valve, and control valve body for loose screws and sticking valves. Repeat step 2.

Table 2-1. Troubleshooting (Cont)

Malfunction	Test or Inspection	Corrective Action
-------------	--------------------	-------------------

TRANSMISSION (CONT)

2. TRANSMISSION NOISY.

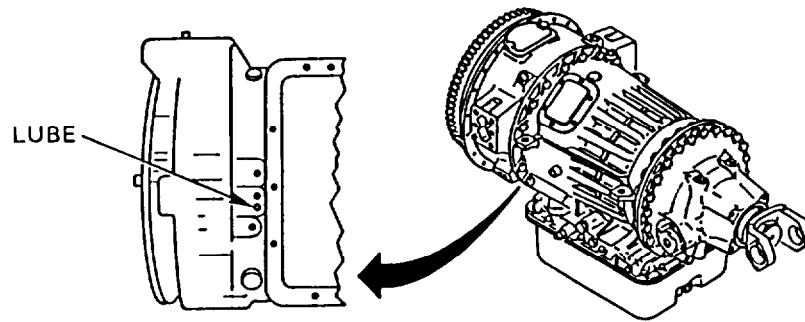

Step 1. Check for low lubrication oil pressure. Remove plug from lube port. Install 0 to 100 psi (0 to 690 kPa) gage. Start engine and allow to run at idle speed. With parking brake applied, shift transmission into DRIVE and accelerate engine to approximately 1900 rpm. Check for 25 to 30 psi (172 to 207 kPa) lube system pressure.

- If pressure is less than 25 or more than 30 psi (172 to 207 kPa), disassemble transmission (page 14-1) and check torque converter, planetary gear assemblies, and bearings for damage.

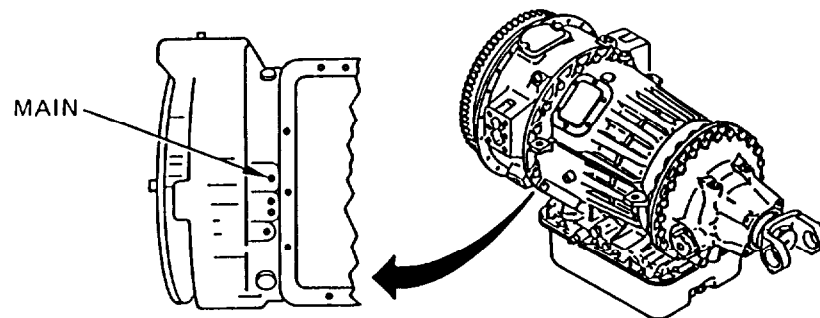

Step 2. Check for low main pressure. Remove oil line (all except M915A2) or plug (M915A2) from main pressure port on transmission and install tee (all except M915A2) and 0 to 300 psi (0 to 2070 kPa) gage. Start engine and allow to run at idle speed (600 rpm). With parking brake applied, shift transmission into DRIVE. Check for 80 to 100 psi (552 to 690 kPa) main system pressure.

- If pressure is less than 80 or more than 100 psi (552 to 690 kPa), disassemble transmission (page 14-27) and inspect lubrication pressure regulator and converter bypass valve for damage. Inspect all other moving parts for damage from lack of oil.

Table 2-1. Troubleshooting (Cont)

Malfunction	Test or Inspection	Corrective Action
-------------	--------------------	-------------------

TRANSMISSION (CONT)

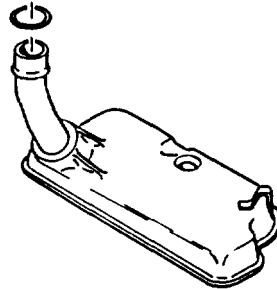

Step 3. Check for clogged internal filter element. Remove internal filter element (page 3-258).

- If internal filter element is clogged, replace internal filter element (page 3-258) and repeat step 2.
- If filter element is not clogged, check for damaged or missing preformed packing on pickup tube. Replace damaged or missing preformed packing (page 3-258) and repeat step 2.
- If transmission is still noisy, disassemble transmission (page 14-27) and inspect oil pump, main pressure regulator valve, converter bypass valve, and lubrication pressure regulator for damage. Inspect all other parts for damage from lack of oil.

Table 2-1. Troubleshooting (Cont)

Malfunction	Test or Inspection	Corrective Action
-------------	--------------------	-------------------

TRANSMISSION (CONT)

3. TRANSMISSION WILL NOT SHIFT INTO GEAR, SLIPS OUT OF GEAR, OR OPERATES ERRATICALLY.

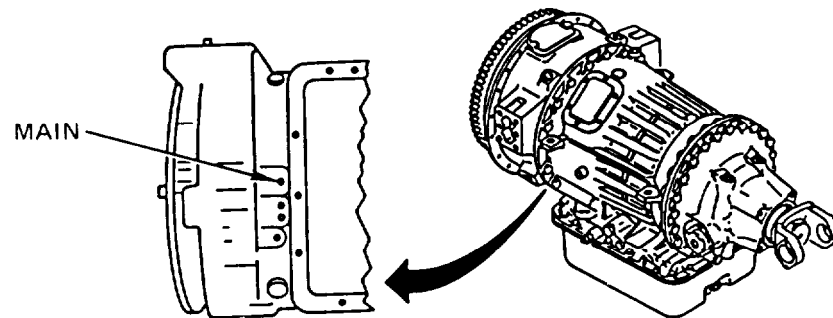

- Step 1. Check for low main pressure. Remove oil line (all except M915A2) or plug (M915A2) from main pressure port on transmission and install tee (all except M915A2) and 0 to 300 psi (0 to 2070 kPa) gage. Start engine and allow to run at idle speed (600 rpm). With parking brake applied, shift transmission into DRIVE. Check for 80 to 100 psi (552 to 690 kPa) main system pressure.
- If pressure is 80 to 100 psi (552 to 690 kPa), go to step 4.

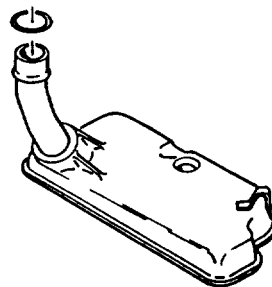

- Step 2. Check for clogged internal filter element. Remove oil pan (TM 9-2320-363-20).
- If internal filter element is clogged, replace internal filter element (page 3-258) and repeat step 1.

Table 2-1. Troubleshooting (Cont)

Malfunction	Test or Inspection	Corrective Action
-------------	--------------------	-------------------

TRANSMISSION (CONT)

Step 3. Check for damaged or missing preformed packing on internal filter pickup tube.

- If preformed packing is damaged or missing, replace preformed packing and gasket (page 3-258) and repeat step 1.
- If preformed packing is not damaged or missing, disassemble transmission (page 14-1) and inspect oil pump, main pressure regulator valve, and control valve body for loose screws and sticking valves.

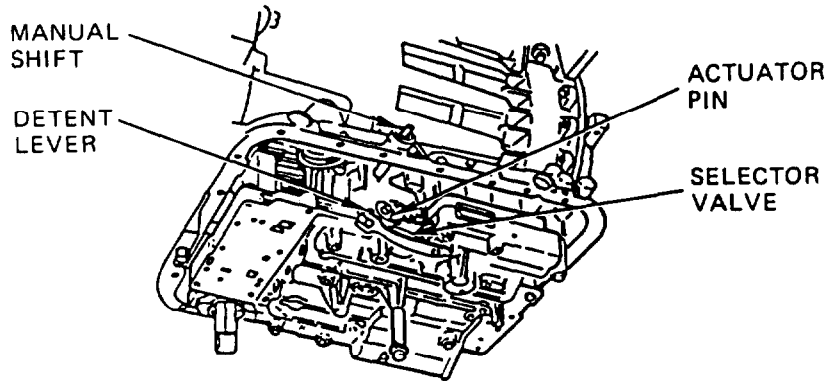

Step 4. Remove oil pan (TM 9-2320-363-20). Manually shift transmission and check that manual shaft and detent lever engage selector valve and that actuator pin is attached to detent lever.

- If selector valve does not engage detent lever, repair selector valve (page 14-74) or replace defective parts (TM 9-2320-363-20).
- If selector valve engages, disassemble transmission (page 14-1) and valve body (page 14-74) and check for worn clutch packs in transmission, loose valve body screws, and sticking valves in valve body.

Table 2-1. Troubleshooting (Cont)

Malfunction	Test or Inspection	Corrective Action
-------------	--------------------	-------------------

TRANSMISSION (CONT)

4. OIL LEAKING AT CONVERTER HOUSING.

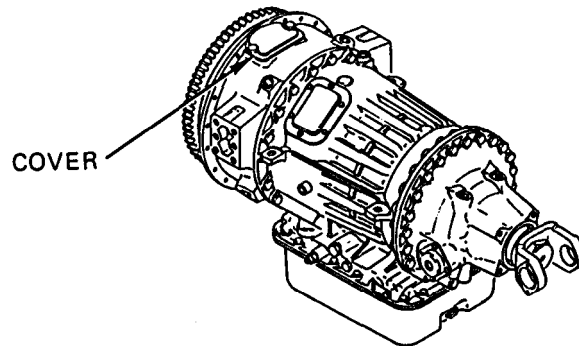

Remove cover from top of converter housing (page 14-7). Check for signs of oil.

- If engine oil is inside housing, replace rear engine crankshaft oil seal (pages 3-141, 3-145).
- If transmission oil is inside housing, inspect inner converter housing mounting screws, converter pump to converter housing seal ring, converter housing gasket, torque converter cover seal ring, oil pump seal, pitot attachment screws, pump hub seal rings, and converter pump hub.

5. EXCESSIVE CREEP IN FIRST AND REVERSE.

Step 1. Check for too high engine speed.

- If idle is more than 600 rpm, adjust engine idle speed (TM 9-2320-363-20).

Table 2-1. Troubleshooting (Cont)

Malfunction	Test or inspection	Corrective Action
-------------	--------------------	-------------------

TRANSMISSION (CONT)

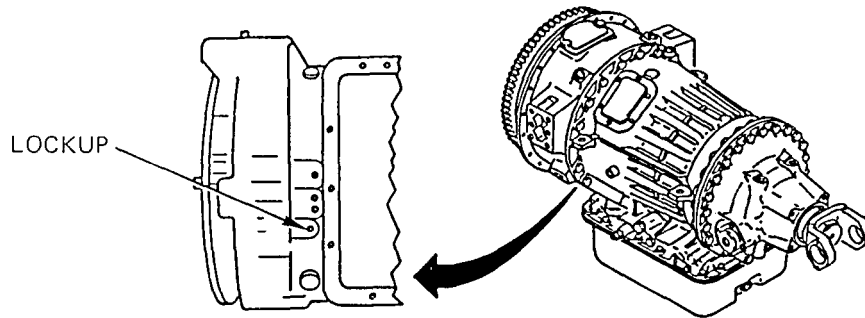

Step 2. Check for lockup pressure at idle speed. Remove pressure switch at transmission lockup port and install tee and 0 to 300 psi (0 to 2070 kPa) gage. Start engine and allow to run at idle speed. With parking brake applied, shift transmission into DRIVE. Check for 0 psi (0 kPa) lockup pressure. There should be no lockup pressure.

- If there is any lockup pressure, inspect lockup clutch valve for sticking pistons (page 3-262).
- If there is no lockup pressure, disassemble transmission (page 14-1) and check for warped clutch plates, stuck (applied) clutch pack pistons, or damaged torque converter to turbine support bearing.

6. AUTOMATIC SHIFTS OCCUR AT TOO HIGH A SPEED.

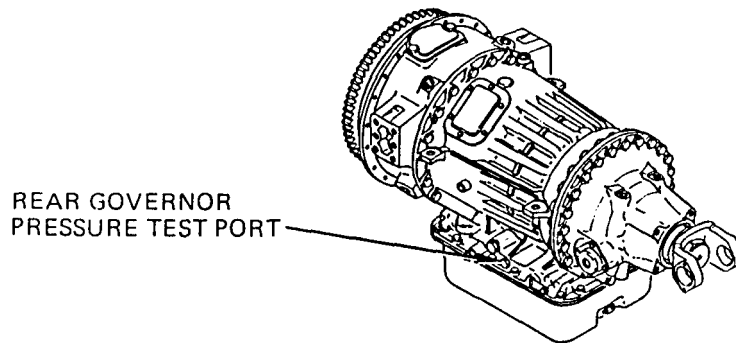

Step 1. Check for low rear governor pressure. Remove plug from rear governor test port. install 0 to 200 psi (0 to 1380 kPa) gage at rear governor test port. Start engine and shift transmission into DRIVE. Release parking brake and drive vehicle until engine tachometer reads approximately 1650 rpm. Check for 100 to 115 psi (690 to 794 kPa) rear governor pressure.

- If pressure is below 100 psi (690 kPa), repair valve body (page 14-74).

Table 2-1. Troubleshooting (Cont)

Malfunction	Test or Inspection	Corrective Action
-------------	--------------------	-------------------

TRANSMISSION (CONT)

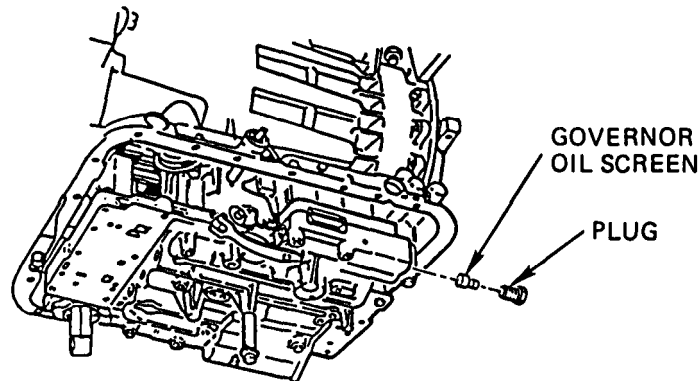

Step 2. Check for clogged governor oil filter screen. Remove oil pan (TM 9-2320-363-20), Remove plug and oil filter screen (page 3-260).

- If oil filter screen is clogged or damaged, clean or replace oil filter screen as required (page 3-260) and repeat step 1.
- If oil filter screen is not clogged or damaged, go to Malfunction 3, steps 1 thru 3.

7. AUTOMATIC SHIFTS OCCUR AT TOO LOW A SPEED, OR SHIFTS ROUGH.

Step 1. Check for defective modulator valve, Remove modulator valve from transmission (TM 9-2320-363-20), Apply 70 psi (483 kPa) air pressure at modulator valve hose fitting. Check that modulator valve plunger moves as air is applied. Modulator valve must not leak air when operated.

- If modulator valve does not operate properly or is damaged, replace modulator valve (TM 9-2320-363-20).

Table 2-1. Troubleshooting (Cont)

Malfunction	Test or Inspection	Corrective Action
-------------	--------------------	-------------------

TRANSMISSION (CONT)

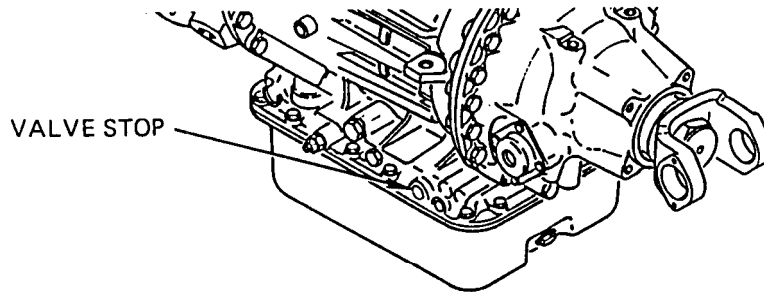

Step 2. Check for defective control valve. Remove modulator valve from transmission (page 3-261). Check valve stop in transmission for free movement. Check that spring pushes valve stop out when released and is not damaged.

- If valve stop does not move freely or spring is damaged or does not push valve stop out, repair control valve (page 14-74).

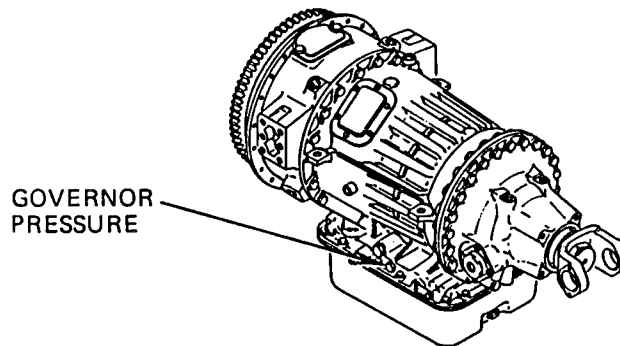

Step 3. Check for high rear governor pressure. Remove plug from rear governor test port. Install 0 to 200 psi (0 to 380 kPa) gage at rear governor test port. Start engine and shift transmission into DRIVE. Release parking brake and drive vehicle until engine tachometer reads approximately 1650 rpm. Check for 100 to 115 psi (690 to 794 kPa) rear governor pressure.

- If pressure is over 115 psi (794 kPa), replace governor valve (page 3-260). If pressure is below 100 psi (690 kPa), repair control valve body (page 14-74).

Table 2-1. Troubleshooting (Cont)

Malfunction	Test or inspection	Corrective Action
-------------	--------------------	-------------------

TRANSMISSION (CONT)

8. VEHICLE MOVES IN NEUTRAL.

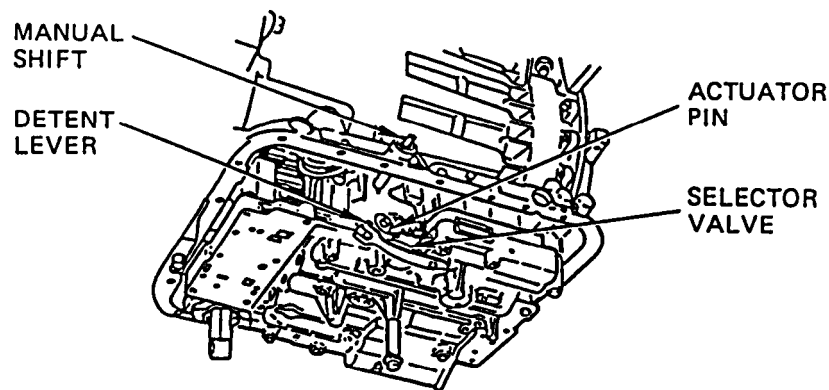

Remove oil pan (TM 9-2320-363-20). Manually shift transmission and check that manual shaft and detent lever engage selector valve and that actuator pin is attached to detent lever.

- If selector valve does not engage detent lever, replace defective parts (TM 9-2320-363-20).
- If selector valve engages, disassemble transmission (page 14-1) and valve body (page 14-74) and check for applied clutch packs in transmission or leaking or sticking valves in valve body.

9. TRANSMISSION SLIPS IN ALL FORWARD GEARS.

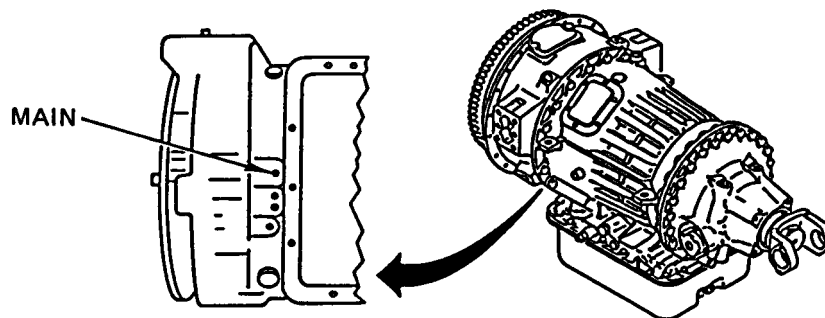

Check for low main pressure. Remove line from main pressure port on transmission and install tee and 0 to 300 psi (0 to 2068 kPa) gage. Start engine and allow to run at idle speed. With parking brake applied, shift transmission into DRIVE. Check for 80 to 100 psi (552 to 690 kPa) main system pressure.

- If pressure is 80 to 100 psi (552 to 690 kPa), rebuild forward clutch (page 14-54).
- If pressure is less than 80 psi (552 kPa), go to Malfunction 3, steps 1 thru 3.

Table 2-1. Troubleshooting (Cont)

Malfunction	Test or inspection	Corrective Action
-------------	--------------------	-------------------

TRANSMISSION (CONT)

10. HIGH STALL SPEED (ABOVE 1200 RPM).

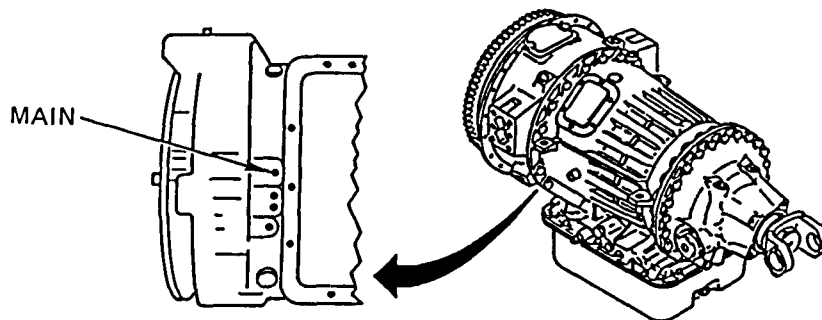

Check for low main pressure. Remove line from main pressure port. install tee and 0 to 300 psi (0 to 2070 kPa) gage. Start engine and allow to run at idle speed. With parking brake applied, shift transmission into DRIVE and accelerate engine to approximately 1200 rpm. Check for 140 to 175 psi (965 to 1206 kPa) main system pressure.

- If pressure is 140 to 175 psi (965 to 1206 kPa), disassemble transmission (page 14-54) and inspect forward and first clutches for damage.
- If pressure is not 140 to 175 psi (965 to 1206 kPa), go to Malfunction 2.

11. LOW STALL SPEED (BELOW 1100 RPM).

Check for damaged torque converter. Disassemble torque converter stator, pump, and housing (pages 14-22, 14-27, 14-35).

- Replace damaged torque converter parts (pages 14-22, 14-27, 14-35).

Table 2-1. Troubleshooting (Cont)

Malfunction	Test or Inspection	Corrective Action
TRANSFER CASE (ALL EXCEPT M915A2)		
1. TRANSFER CASE WILL NOT ENGAGE, SHIFT CONTROL CABLE AND LINKAGE IS OPERATIVE.	Check for internal binding or broken linkage.	<ul style="list-style-type: none"> ● Repair (page 15-2) or replace transfer case (page 3-234).
2. TRANSFER CASE WILL NOT ENGAGE IN HIGH RANGE, LOW RANGE IS OPERATIVE, SHIFT CONTROL CABLE AND LINKAGE IS OPERATING.	Check for binding or broken high range-shaft or gears.	<ul style="list-style-type: none"> ● Repair (page 15-2) or replace transfer case (page 3-234).
3. TRANSFER CASE WILL NOT ENGAGE IN LOW RANGE, HIGH RANGE IS OPERATIVE, SHIFT CONTROL CABLE AND LINKAGE IS OPERATING.	Check for binding or broken low-range shaft or gears.	<ul style="list-style-type: none"> ● Repair (page 15-2) or replace transfer case (page 3-234).
4. TRANSFER CASE OVERHEATS DURING OPERATION, LUBRICATION AT PROPER LEVEL.	Check for failed bearings.	<ul style="list-style-type: none"> ● Repair (page 15-2) or replace transfer case (page 3-234).
5. TRANSFER CASE EXCESSIVELY NOISY.	Step 1. Check for proper oil level.	<ul style="list-style-type: none"> ● Service transfer case (TM 9-2320-363-20).
	Step 2. Check for worn bearings and gears.	<ul style="list-style-type: none"> ● Repair (page 15-2) or replace transfer case (page 3-234).

Table 3-1. Troubleshooting (Cont)

Malfunction	Test or Inspection	Corrective Action
-------------	--------------------	-------------------

STEERING

1. ABNORMAL NOISE.

Step 1. If clicking noise is heard when initiating steering maneuver or when changing directions of turn, some linkage component is probably loose and shifting under load.

- Tighten or replace loose or defective components,

Step 2. Check for excessive air in fluid (fluid is foamy) and/or low fluid level.

- Fill pump reservoir to proper level (TM 9-2320-363-20).

2. NO RECOVERY.

Step 1. Disconnect lower steering column from steering gear and check both upper and lower columns for binding.

- Replace defective column or universal joint (TM 9-2320-363-20).

Step 2. Check for sufficient pump pressure as follows:

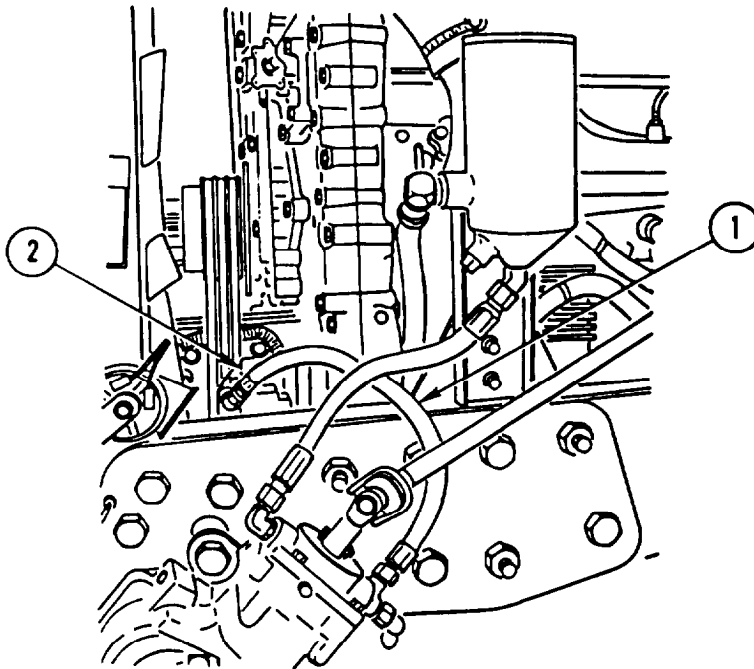

- a. Disconnect pressure hose (1) from power steering pump (2).

Table 2-1. Troubleshooting (Cont)

Malfunction

Test or Inspection

Corrective Action

STEERING (CONT)

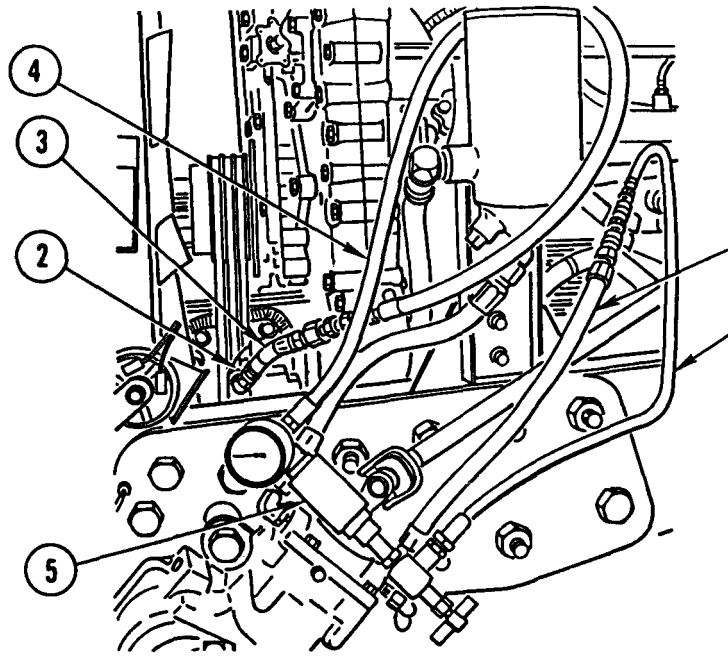

- b. Connect adapter hose P/N J-28593 (3) to power steering pump (2).
- c. Connect hose (4) from dial end of flow/pressure tester P/N J-26487-B (5) to adapter hose (3).
- d. Connect hose (6) from load valve end of flow/pressure tester (5) to pressure hose (1).

CAUTION

Before performing step e, make sure load valve is completely open to prevent damage to flow/pressure valve.

- e. With engine idling, rotate steering wheel to left and right for 5 minutes to warm power steering fluid.

Table 2-1. Troubleshooting (Cont)

Malfunction	Test or Inspection	Corrective Action
-------------	--------------------	-------------------

STEERING (CONT)

CAUTION

To prevent damage to power steering pump during performance of step f, do not allow load valve to be closed for more than 5 seconds.

- f. With engine idling, close load valve and read pressure gage. Pressure must be 900 to 1000 psi (621 to 690 kPa).
 - If pressure is less than 900 psi (621 kPa), repair (page 19-2) or replace power steering pump (page 7-2).

Step 3. Check for sufficient pump flow as follows:

- a. Perform steps a thru e of step 2.

WARNING

Maximum flow rate is 7 gpm (26.5 liters/rein). Flow rate in excess of 7 gpm (26.5 liters/rein) will damage steering gear and could cause loss of steering and injury to personnel.

- b. With engine idling, read flow meter. Rate of flow must be 7 gpm (26.5 liters/rein).
 - Repair (page 19-2) or replace power steering pump (page 7-2).
- c. With engine idling, close load valve until pressure gage indicates pump relief and pump relief pressure drops to 0. Immediately open load valve. Flow rate must return to 7 gpm (26.5 liters/rein).
 - Repair (page 19-2) or replace power steering pump (page 7-2).
- d. Run engine at 2100 rpm and fully close load valve until pressure gage indicates pump relief and flow rate drops to 0. Immediately open load valve. Flow rate must return to 7 gpm (26.5 liters/rein).
 - Repair (page 19-2) or replace power steering pump (page 7-2).

Step 4. Check for defective teflon seals in steering control valve.

- Repair (page 19-8) or replace steering gear (page 7-4).

Table 3-1. Troubleshooting (Cont)

Malfunction	Test or Inspection	Corrective Action
-------------	--------------------	-------------------

STEERING (CONT)

Step 5. Check for steering gear control valve sticking.

- Repair (page 19-8) or replace steering gear (page 7-4).

3. EXTERNAL OIL LEAKS FROM STEERING GEAR.

NOTE

External leakage is not acceptable from steering gear.

Step 1. Check for leak at rubber relief plug (on frame side of steering gear).

- Repair (page 19-8) or replace steering gear (page 7-4).

Step 2. Check for leak at shaft seals.

- Repair (page 19-8) or replace steering gear (page 7-4).

4. OVERSTEER OR DARTING.

Step 1. Disconnect lower steering column from steering gear and check both upper and lower columns for binding.

- Replace defective column or universal joint (TM 9-2320-363-20).

Step 2. Disconnect steering gear pitman arm and check front end components for binding.

- Replace defective components (TM 9-2320-363-20).

5. HIGH STEERING EFFORT IN ONE DIRECTION.

Step 1. Check for sufficient pump pressure (Malfunction 2, step 2).

- If pressure is less than 900 psi (621 kPa), repair (page 19-2) or replace power steering pump (page 7-2).

Step 2. Check for sufficient pump flow (Malfunction 2, step 3).

- Repair (page 19-2) or replace power steering pump (page 7-2).

Step 3. Check for defective teflon seals in steering control valve.

- Repair (page 19-8) or replace steering gear (page 7-4).

Step 4. Check for steering gear control valve sticking.

- Repair (page 19-8) or replace steering gear (page 7-4).

Table 3-1. Troubleshooting (Cont)

Malfunction	Test or Inspection	Corrective Action
-------------	--------------------	-------------------

STEERING (CONT)

6. HIGH STEERING EFFORT IN BOTH DIRECTIONS.

Step 1. Disconnect lower steering column from steering gear and check both upper and lower columns for binding.

- Replace defective column or universal joint (TM 9-2320-363-20).

Step 2. Disconnect steering gear pitman arm and check front end components for binding.

- Replace defective components (TM 9-2320-363-20).

Step 3. Check for sufficient pump pressure (Malfunction 2, step 2).

- If pressure is less than 900 psi (621 kPa), repair (page 19-2) or replace power steering pump (page 7-2).

Step 4. Check for sufficient pump flow (Malfunction 2, step 3).

- Repair (page 19-2) or replace power steering pump (page 7-2).

HYDRAULIC WINCH (M916A1 AND M916A2)

1. NO OR LOW OIL FLOW FROM PUMP.

Check for broken input shaft and internal parts.

- Repair (page 23-12) or replace winch hydraulic pump (page 11-2).

2. EXTERNAL LEAKS.

Check for damaged packings.

- Replace damaged packings (pages 23-9, 23-12).

3. DELIVERS LESS THAN OR NO RATED PULL.

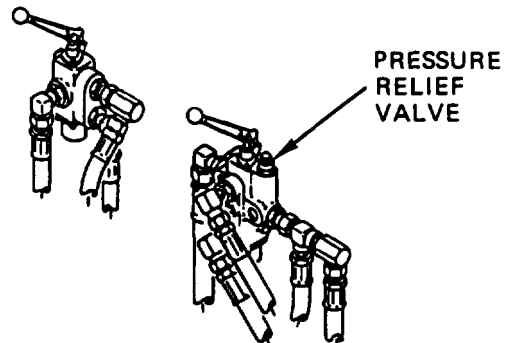
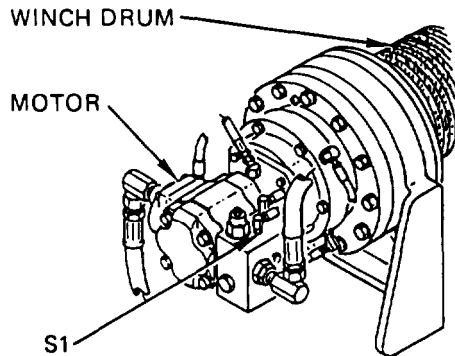

Table 2-1. Troubleshooting (Cont)

Malfunction	Test or Inspection	Corrective Action
-------------	--------------------	-------------------

HYDRAULIC WINCH (M916A1 AND M916A2 (CONT))

Check pressure relief valve setting. Install pressure gage with capacity of 3000 psi (20695 kPa) in brake pilot line and plug port S1 in counterbalance manifold. Apply hydraulic power, run engine at 1000 rpm, and observe pressure on gage.

CAUTION

To prevent damage to equipment, do not try to adjust counterbalance valve. It is a sealed non-adjustable unit.

- If pressure is less than 2500 ±50 psi (17250 ±345 kPa), replace relief valve on control valve (page 23-22).
- If pressure is normal, replace hydraulic motor (page 11-15).

4. DOES NOT HOLD LINE IN NEUTRAL.

Step 1. Check for damaged packings.

- Replace damaged packings (pages 23-9, 23-12).

Step 2. Check for damaged or broken brake springs.

- Repair winch brake (page 23-34).

Step 3. Check for damaged or worn friction plates.

- Repair winch brake (page 23-34).

5. BRAKE WILL NOT RELEASE.

Step 1. Check for leaking packings and connections.

- Replace leaking motor packings (page 23-9) pump packings (page 23-12) and tighten loose connections. If problem still exists, go to step 2.

Table 3-1. Troubleshooting (Cont)

Malfunction	Test or Inspection	Corrective Action
-------------	--------------------	-------------------

HYDRAULIC WINCH (M916A1 AND M916A2) (CONT)

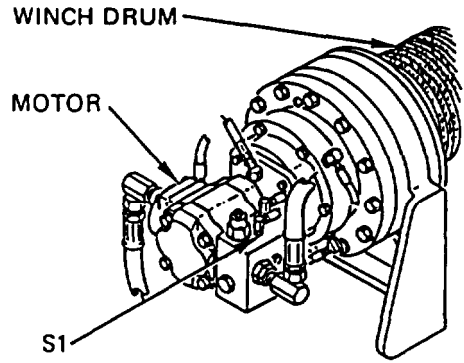

Step 2. Check for insufficient system pressure to brake. Check hydraulic system pressure. Install pressure gage with capacity of 3000 psi (20685 kPa) in brake pilot line and plug port S1 in counterbalance manifold. Apply hydraulic power, run engine at 1000 rpm, and observe pressure on gage.

- If pressure is below 270 psi (1861 kPa), repair (page 23-12) or replace hydraulic pump (page 11-2).
- If pressure is at least 270 psi (1861 kPa), check for jammed gearing in winch, or repair brake (pages 23-2, 23-26, 23-34).

6. BRAKE WILL NOT APPLY. OR APPLIES BUT TORQUE LOW.

Check for damaged springs or friction plates.

- Repair (page 23-9) or replace hydraulic motor (page 11-15).

ARCTIC HEATER

1. HEATER WILL NOT START, BLOWER DOES NOT RUN.

Step 1. Check for damaged wiring.

- Repair (page 25-34) or replace wiring (page 25-34).

Step 2. Check for defective blower motor.

- Replace blower motor (page 25-26).

2. BLOWER RUNS WHEN SWITCH IS IN START POSITION, BUT HEATER WILL NOT IGNITE.

Step 1. Check for defective flame detector switch.

- Replace flame detector switch (page 25-30).

Table 3-1. Troubleshooting (Cont)

Malfunction	Test or Inspection	Corrective Action
ARCTIC HEATER (CONT)		
	Step 2. Check for defective fuel control valve.	<ul style="list-style-type: none"> • Replace fuel control valve (page 25-14).
	Step 3. Check for defective thermostat,	<ul style="list-style-type: none"> • Replace thermostat switch (page 25-18).
	Step 4. Check for defective fixed resistor.	<ul style="list-style-type: none"> • Replace fixed resistor (page 25-22).
3. BLOWER RUNS WHEN SWITCH IS IN START POSITION AND HEATER IGNITES, BUT PILOT LAMP WILL NOT LIGHT.	Check for defective flame detector switch.	<ul style="list-style-type: none"> • Reset, or replace flame detector switch (page 25-30).
4. HEATER STARTS AND RUNS BUT GOES OUT LATER.	Step 1. Check for restriction in coolant flow.	<ul style="list-style-type: none"> • Clear restriction from hose(s) (TM 9-2320-363-20).
	Step 2. Check for defective thermostat.	<ul style="list-style-type: none"> • Replace thermostat (page 25-28).
	Step 3. Check for defective fuel control valve.	<ul style="list-style-type: none"> • Replace fuel control valve (page 25-14).
5. HEATER OVERHEATS.	Step 1. Check for defective fuel control valve.	<ul style="list-style-type: none"> • Replace fuel control valve (page 25-14).
	Step 2. Check for defective thermostat.	<ul style="list-style-type: none"> • Replace thermostat (page 25-28).
	Step 3. Check for restriction in coolant flow.	<ul style="list-style-type: none"> • Clear restriction from hose(s) (TM 9-2320-363-20).
6. HEAT OUTPUT LOW.	Step 1. Check for defective fuel control valve.	<ul style="list-style-type: none"> • Replace fuel control valve (page 25-14).

Table 3-1. Troubleshooting (Cont)

Malfunction	Test or Inspection	Corrective Action
ARCTIC HEATER (CONT)		
	Step 2. Check for defective thermostat.	<ul style="list-style-type: none"> • Replace thermostat (page 25-28).
7. HEATER BURNS ON HIGH HEAT CONTINUOUSLY.	Check for defective diode.	<ul style="list-style-type: none"> • Replace diode (page 25-11).
8. HEATER BURNS ON LOW HEAT CONTINUOUSLY.	Step 1. Check for defective thermostat.	<ul style="list-style-type: none"> • Replace thermostat (page 25-28).
	Step 2. Check for defective diode.	<ul style="list-style-type: none"> • Replace diode (page 25-11).
9. HEATER SMOKES EXCESSIVELY.	Step 1. Check for leaking fuel control valve.	<ul style="list-style-type: none"> • Replace fuel control valve (page 25-14).
	Step 2. Check for restriction in exhaust system.	<ul style="list-style-type: none"> • Clean exhaust system.
	Step 3. Check for low voltage at batteries.	<ul style="list-style-type: none"> • Replace batteries (TM 9-2320-363-20).
10. BLOWER WILL NOT STOP WHEN HEATER IS SHUT OFF.	Check for defective flame detector switch.	<ul style="list-style-type: none"> • Replace flame detector switch (page 25-30).

TROUBLESHOOTING AND TESTING THE AIR CONDITIONING SYSTEM (All Except M915A2 and M916A1)

Preliminary Checks

Before testing the operation of the air conditioning system, make the following checks:

1. Make sure the refrigerant compressor's drive belt is not damaged and is correctly tensioned. Also check the compressor mountings for tightness.
2. Check for broken, burst, or cut hoses; also check for loose fittings on all parts.
3. Check for road debris build-up on the condenser coil fins. Using air pressure and a whiskbroom or a soapy spray of water, carefully clean off the condenser; be careful not to bend the fins.
4. Check the color of the moisture indicator sight glass. If the color is a deep cobalt blue, the refrigerant charge is dry. If the indicator is not blue, the system is contaminated with moisture; recover the refrigerant, evacuate the system, replace the receiver-drier, and add a full refrigerant charge.
5. If there is not enough airflow, make sure that leaves or other debris has not entered the fresh air ports under the windshield. If debris has entered, it could clog the fins of the evaporator core, and block airflow.

Also, be sure that all ducts are connected to the dash louvers and that the air-control flaps in the heater housing are moving properly (this requires removal of the right and center dash panel).

Performance Tests

Following is a brief description of symptoms or conditions that could exist if something goes wrong with a refrigerant part.

RECEIVER-DRIER

The receiver-drier is normally at outside temperature. To the touch, the entire length of the unit should be the same temperature. If noticeable

cool spots exist, replace the receiver-drier.

A blockage at the inlet of the unit will cause high head pressures; outlet blockages will cause low head pressures and little or no cooling.

If the moisture indicator is pink or white (showing that the system is wet), the receiver-drier is saturated with moisture and must be replaced.

COOLING SYSTEM

Although they are not physically connected, there is a close tie between a vehicle's air conditioner and its cooling system. Poor air conditioner cooling can be the result of a problem in the cooling system.

If the cooling system does not work correctly, the heat of the engine will rise to abnormal levels. The added heat will transfer to the air conditioner, other underhood parts, and maybe make its way into the cab. The added heat makes it necessary for the air conditioner to work harder and at the same time, it reduces the air conditioner's ability to cool down the air in the cab. Also, if the water regulating valve isn't closing all the way, heat will enter the cab, giving the impression that the air conditioning system is not working.

Refer to the engine cooling section for cooling system troubleshooting.

EXPANSION VALVE

Problems that start in the expansion valve show up as follows: when stuck closed, the evaporator coil and the expansion valve will be at outside temperature; when stuck open, both the coil and the valve will be extremely cold with frost or ice build-up.

Because the expansion valve channels are very small, blockages in the system tend to be found here (the valve is very sensitive to contamination). Usually, the contaminant is water; less than a drop of water is all it takes to make the valve inoperative. When water reaches the valve, the extreme cold that results from the pressure drop freezes the water, forming a block of ice in the valve. After the system shuts down and the valve warms up, the ice melts, and the valve operates again, only to freeze up when moisture returns.

On-and-off operation of the expansion valve means that the receiver-drier is not removing moisture from the system. These contaminants should cause the moisture indicator's element to turn white and then pink.

REFRIGERANT COMPRESSOR

Compressor problems usually show in one of four ways: abnormal noise; seizure; leakage; or low suction and discharge pressures.

Resonant compressor noises are not causes for alarm; irregular noise or rattles are likely to be caused by broken parts. To check for seizure, de-energize the magnetic clutch and see if the drive plate can be turned. If it won't turn, the compressor has seized.

Low discharge pressure may be caused by not enough refrigerant, not enough belt tension, or a blockage somewhere in the system. These things should be checked before servicing the compressor.

EVAPORATOR

The evaporator coils are basically trouble-free when airflow over the fins is not blocked. External or, less often, internal blockages will cause low suction pressure as well as little or no cooling.

If a leak exists in the system, and it cannot be traced to other parts or fittings, suspect damage to one of the evaporator coils.

CONDENSER

The condenser is usually trouble-free. Normally, the temperature of the condenser outlet line is noticeably cooler than the inlet line. However, when road debris (such as leaves or dirt buildup) cakes up, airflow over the condenser fins is blocked; air is not able to absorb enough heat to turn the hot refrigerant gas into a liquid. High head pressures will result. In these cases, carefully clean off the outer surfaces of the condenser with compressed air or a soap and water solution; be careful not to bend the fins.

High head pressures will also occur if the condenser's tubing is abnormally bent, blocking the flow of refrigerant. Frost will appear at the point where the flow is restricted.

Less common internal blockages (bits of foreign material or metallic grit build-up) will stop the flow of refrigerant.

A quick test to check that poor system performance is caused by the condenser is to direct a spray of water onto the condenser while the system is running. If the air conditioner cools better because of the assist provided by the water, it is a sign that the condenser is not working.

When troubleshooting a suspected condenser problem, remember that the problem may be caused by the radiator transferring high levels of heat to the condenser. Refer to the radiator section for cooling system troubleshooting.

THERMOSTATIC SWITCH

IMPORTANT: Before troubleshooting the thermostatic switch, be sure there is a full charge of refrigerant in the system. The compressor will not operate, or will cycle too often, if there is not enough refrigerant in the system.

Quick or delayed cycling of the compressor may be caused by a thermostatic switch that is working, but is out of adjustment. If, after doing the tests below, the switch seems to be out of adjustment, replace it (the thermostatic switch cannot be recalibrated).

1. Be sure the compressor clutch is operating correctly.
2. Expose the evaporator coil.
3. Start the engine. Place the air conditioner control at its coldest setting; turn on the air conditioner and the fan.
4. Place an accurate thermometer in contact with a tube on the evaporator coil. Be sure the thermometer is in good contact with the tube, or you will get a wrong reading.

When the temperature drops below 31° to 36°F (-1° to 2°C), the compressor clutch should disengage and remain this way until the temperature rises to 39° to 44°F (4° to 7°C).

5. If the compressor did not engage when the temperature was above the accepted high range, do the following test:
 - 5.1 Connect a voltmeter or a test light from one of the terminals on the thermostatic switch to ground. Repeat this test with the other terminal on the switch.

- 5.2 With the engine running and the air conditioner and blower on, both terminals will show voltage when the compressor should be engaged; one terminal will show voltage when the compressor should be disengaged.

If there is no voltage, there is a problem in the electrical system from the batteries to the thermostatic switch. Check all circuits for the cause, and repair or replace the wiring or parts.

In all other cases where the compressor is not engaging and disengaging properly, the thermostatic switch is the cause. Replace it with a new switch.

6. Shut down the engine and, to prevent accidental electric shock or shorting during dash assembling, disconnect the batteries.

7. Assemble the dash.

LINE RESTRICTIONS

A restricted suction line causes low suction pressure at the compressor and little or no cooling. A restriction in a line between the compressor and the expansion valve can cause high discharge and low suction pressure, and insufficient cooling.

Usually, areas of ice or frost build-up mean a blockage. Parts that often freeze up are probably corroded or inoperative and should be replaced. Parts (such as the expansion valve) that freeze up once in a while may do so because of moisture in the system, which will cause the moisture indicator's element to turn white or pink; if this happens, recover the refrigerant charge, evacuate/recycle the system refrigerant, replace the receiver-drier, and install a new charge.

Safety Precautions

Whenever repairs are made to any air conditioner parts that hold refrigerant, you must discharge, purge or flush (if contaminated), evacuate, charge and leak test the system. In a good system, refrigerant lines are always under pressure and you should disconnect them only after the air conditioning system has been discharged to a refrigerant recovery unit through the service valves on the compressor.

Refrigerants are safe when used under the right conditions. Always wear safety goggles and non-leather gloves while discharging, purging, flushing, evacuating, charging, and leak testing the system. Do not wear leather gloves; when refrigerant gas or liquid contacts leather, the leather will stick to your skin.

WARNING: Use care to prevent refrigerant from touching your skin or eyes, because liquid refrigerant, when exposed to the air, quickly evaporates and will freeze skin or eye tissue. Serious injury or blindness could result if you come in contact with liquid refrigerant.

Refrigerant splashed in the eyes should first be treated with a few drops of sterile mineral oil in the eyes, then rinsed with a weak boric acid solution. Do not rub the eyes. Call a doctor right away.

Refrigerant splashed on the skin should be treated the same as for frostbite: gently pour cool water on the area, but do not rub the skin. Keep the skin warm with layers of soft, sterile cloth. Call a doctor right away.

Even though refrigerant does not burn, when it contacts extreme heat or flame, poisonous phosgene gas is created. This gas is also produced when an open flame leak detector is used. Phosgene fumes have an acrid (bitter) smell.

WARNING: Do not work in an area where refrigerant may contact an open flame or any burning material, such as a cigarette. When it contacts extreme heat, refrigerant breaks down into poisonous phosgene gas which, if breathed, causes severe respiratory irritation. Do not breathe the fumes from an open flame leak detector.

You must work in an area where there is a constant flow of fresh air when the system is

discharged, flushed, charged, and leak tested using an open flame leak detector.

Changes in both federal and state laws will affect the way dealerships service air conditioning systems. Under current federal laws, refrigerant must be recovered and recycled by all users to protect the environment, and not released into the atmosphere. Many service operations not directly involving the air-conditioning system require the release of the refrigerant charge. Under the new regulations, dealerships not having the required recovery and recycling equipment (and properly trained and certified personnel) will not be allowed to do any of this service work.

Because of its very low boiling point, refrigerant must be stored under pressure. To prevent the refrigerant cans from exploding, never expose them to temperatures higher than 125°F (52°C). Never leave refrigerant cans in the sun, and do not store them in sun-exposed areas where heat can build up, such as in gloveboxes, automobile trunks, etc.

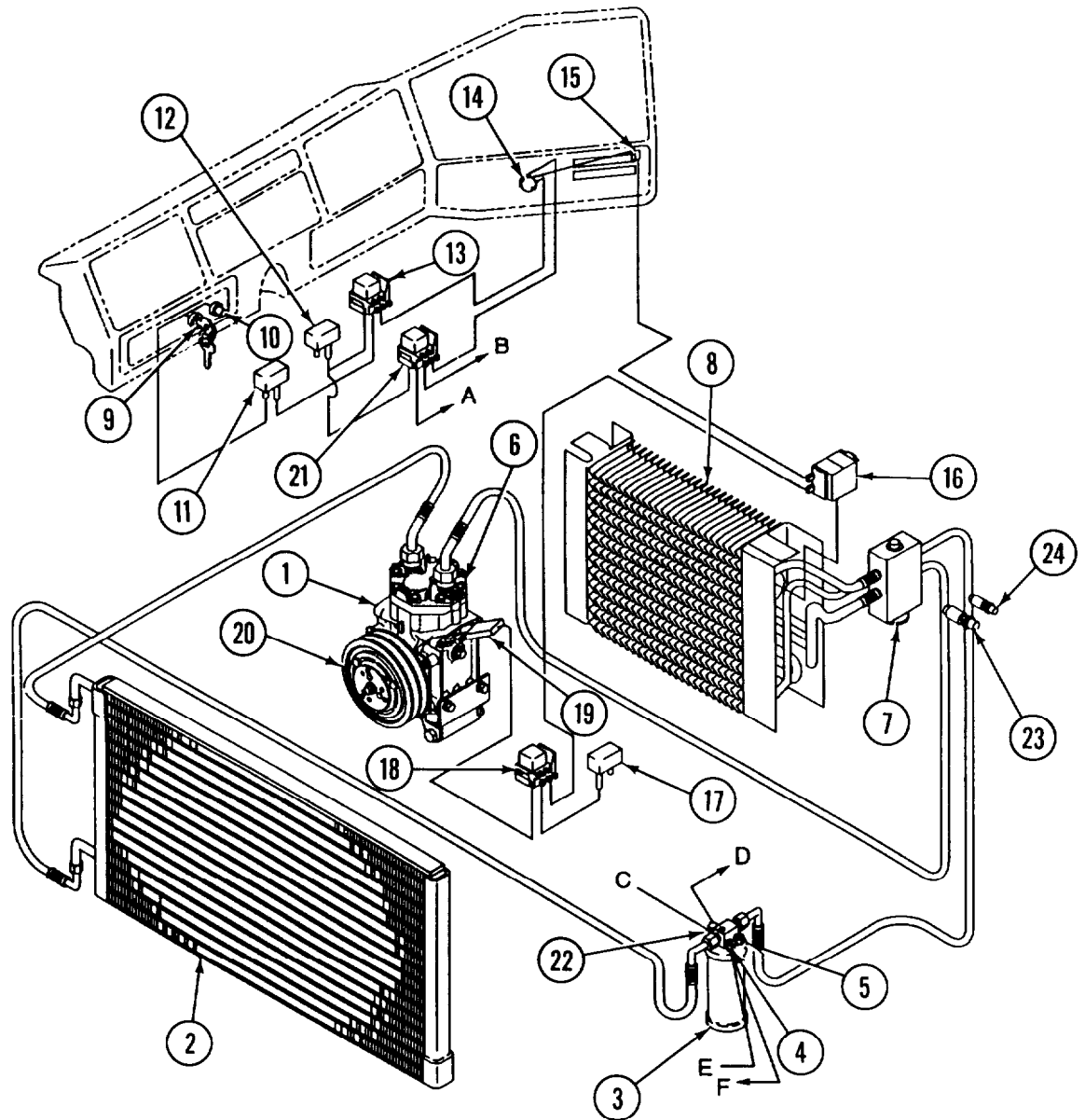

A. to resistor block
 B. to blower motor
 C. from engine fan thermal switch

D. to engine fan thermal switch
 E. from a/c clutch relay
 F. to compressor clutch

- | | | |
|-------------------------------|---------------------------|-----------------------------|
| 1. Compressor | 9. Ignition Switch | 17. Circuit Breaker (15A) |
| 2. Condenser | 10. Start Button | 18. A/C Clutch Relay |
| 3. Receiver-Drier | 11. Circuit Breaker (10A) | 19. Diode |
| 4. Binary Switch | 12. Circuit Breaker (30A) | 20. Compressor Clutch |
| 5. Moisture Indicator | 13. Power Relay | 21. High-Speed Relay |
| 6. High Pressure Relief Valve | 14. Blower Switch | 22. Fan Cycling Switch |
| 7. Expansion Valve | 15. "On-Off" Microswitch | 23. Discharge Service Valve |
| 8. Evaporator | 16. Thermostatic Switch | 24. Suction Service Valve |

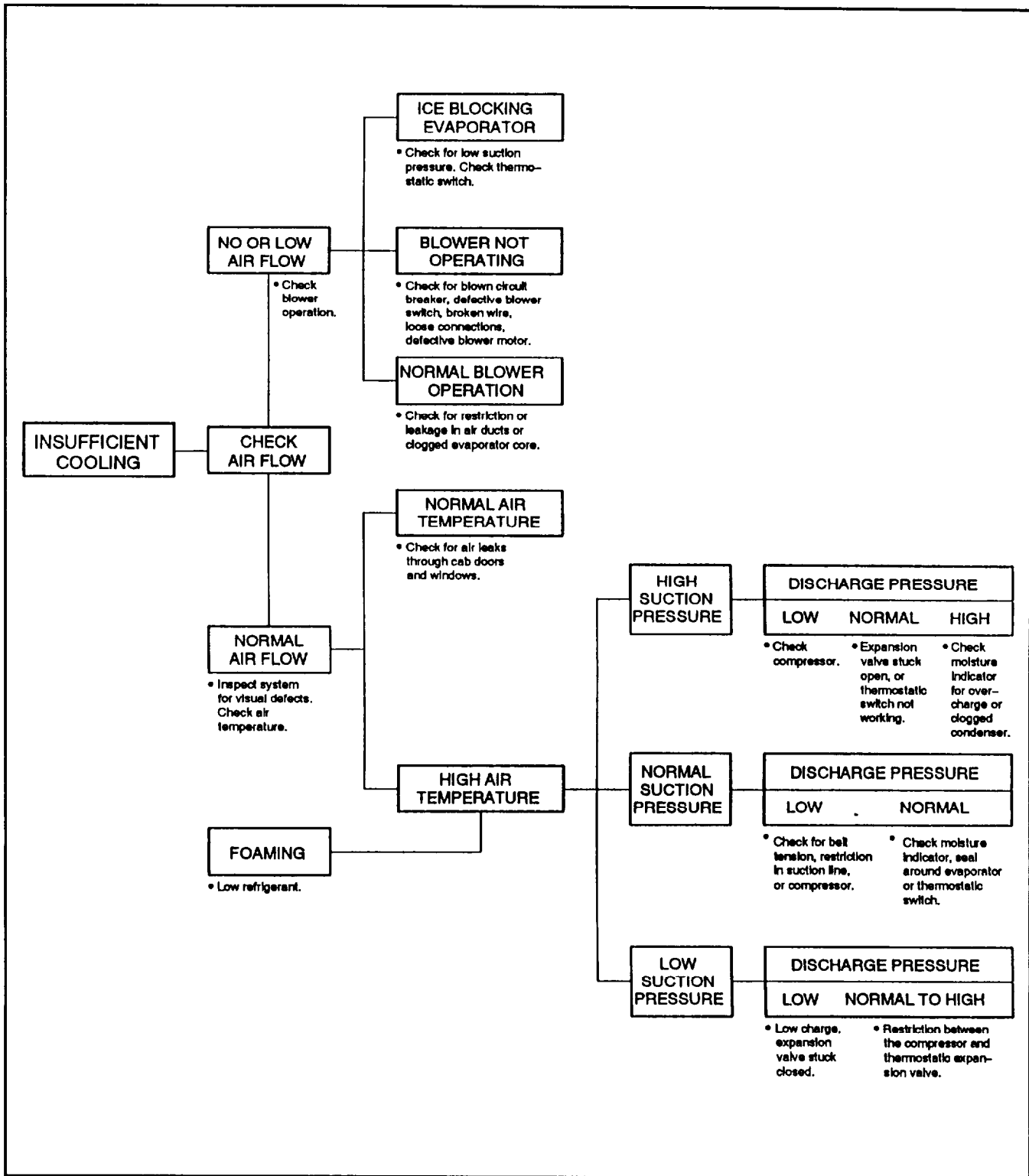

PROBLEM - LITTLE OR NO AIRFLOW

Possible Cause	Remedy
<p>The blower is not operating</p> <p>There are restrictions or leaks in the air ducts.</p> <p>ice has formed on the evaporator coil.</p>	<p>Check for an open circuit breaker. An open circuit indicates a short in the electrical system, which must be located and repaired.</p> <p>Check the air conditioner relays for operation. Replace as necessary.</p> <p>Make sure the blower motor switch is working. Replace if necessary.</p> <p>Check the wiring to the blower motor. if any connections are loose, securely tighten them.</p> <p>Check the blower motor for operation. Replace if sticking or otherwise inoperative.</p> <p>Check the resistor block. Replace if necessary.</p> <p>CAUTION: Never try to bypass the fuse in the resistor block. To do so could cause the blower motor to overheat, resulting in serious damage to the heater/air-conditioning system.</p> <p>Examine ail air ducts and remove any blockages. Stop any leaks or replace any portion where the leaks cannot be stopped.</p> <p>Defrost the evaporator coil before resuming operation of the air conditioner.</p>

PROBLEM - WARM AIRFLOW WHEN AIR CONDITIONER IS ON

Possible Cause	Remedy
<p>There is no refrigerant charge in the system.</p> <p>Moisture in the system.</p> <p>The refrigerant compressor is not operating.</p>	<p>Repair any leaks, evacuate the system, replace receiver-drier, and add a full charge of refrigerant.</p> <p>If moisture is in the system, ice crystals may form at the expansion valve, blocking the flow of refrigerant (off and on). Recover the refrigerant charge, replace the receiver-drier, evacuate the system, and add a full charge of refrigerant.</p> <p>If the refrigerant charge is low, charge the system. Repair any leaks. The refrigerant compressor clutch needs repair or replacement.</p>

PROBLEM - LOW EVAPORATOR COIL OUTLET PRESSURE (LOW COMPRESSOR SUCTION PRESSURE)

Possible Cause	Remedy
<p>The expansion valve is not working.</p> <p>There are restrictions in the line to the expansion valve.</p> <p>There is an insufficient refrigerant charge in the system.</p>	<p>Replace the expansion valve.</p> <p>Remove the line restrictions.</p> <p>Locate the leak. Recover the charge, replace the receiver-drier, and add a full refrigerant charge.</p>

PROBLEM - HIGH COMPRESSOR DISCHARGE PRESSURE

Possible Cause	Remedy
There is an internal restriction in the condenser. (Ice buildup on the condenser or a cool spot on the line from the condenser to the receiver-drier).	Replace the condenser.
Air is present in the system.	Repair any leaks, evacuate the system, and add a full charge of refrigerant.
Restriction in the compressor discharge line.	Repair or replace the line.

PROBLEM - EVAPORATOR OUTLET AIR TEMPERATURE INCREASES AS COMPRESSOR DISCHARGE PRESSURE DROPS

Possible Cause	Remedy
The expansion valve setting is too low.	Replace the expansion valve. Add a full charge of refrigerant.

PROBLEM - COMPRESSOR OPERATES TOO OFTEN OR CONTINUOUSLY

Possible Cause	Remedy
There is too little refrigerant in the system.	Repair any leaks, and add a full charge of refrigerant.
There is a restriction in the refrigerant system.	Remove the restriction from the line.

Possible Cause	Remedy
The thermostatic switch operates, but is out of adjustment.	Replace the thermostatic switch. Do not attempt to adjust it.
Loss of refrigerant is causing a delayed cycling of the compressor.	Add a full charge of refrigerant.

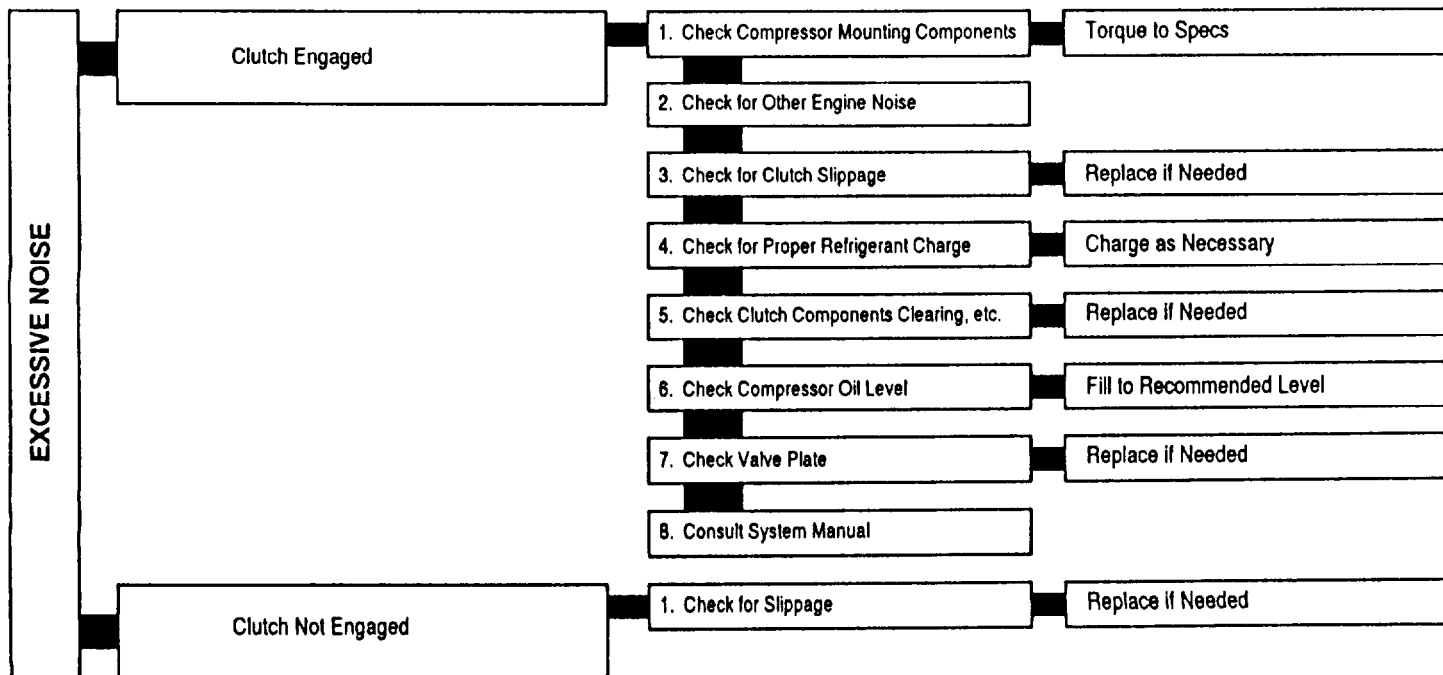
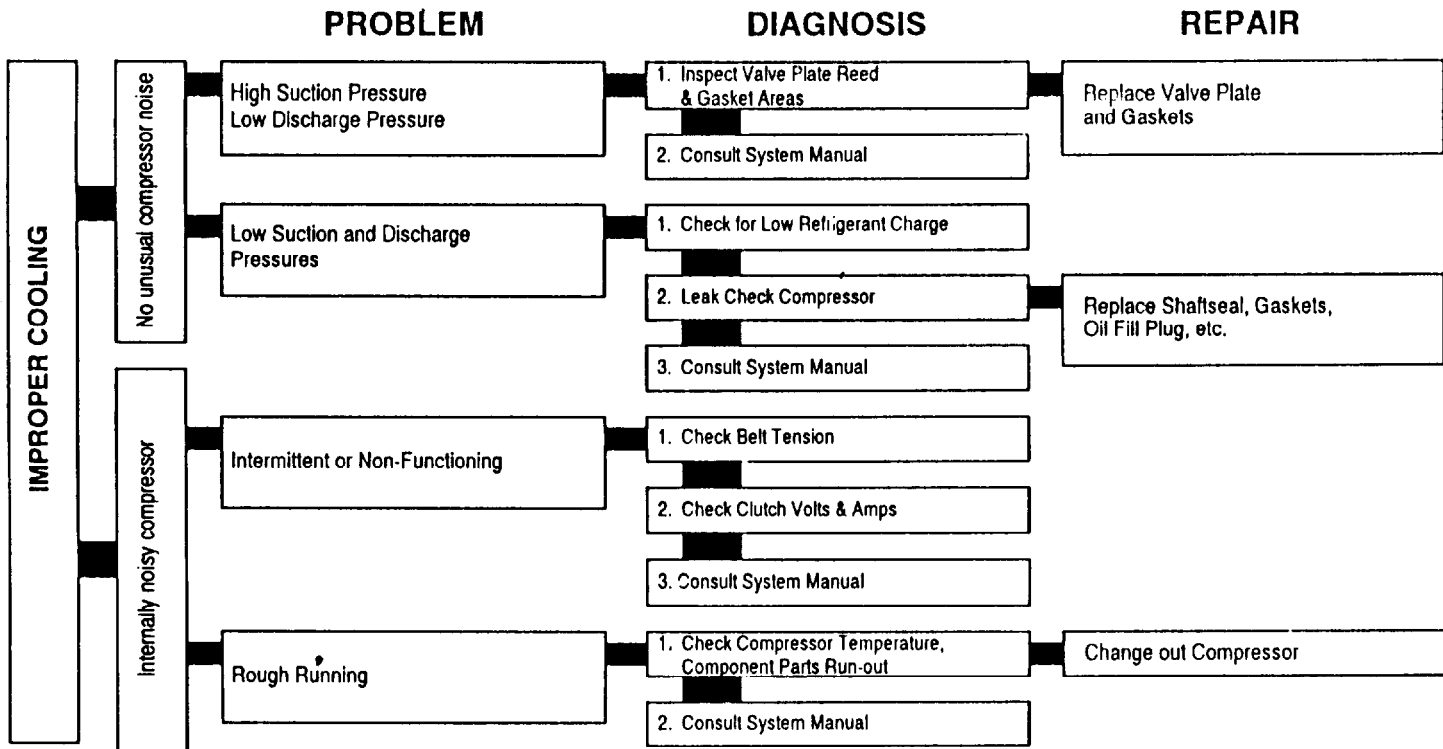

Section III. GENERAL MAINTENANCE INSTRUCTIONS

OVERVIEW

This section describes general maintenance instructions that apply to all parts of this manual. To avoid repetition, these procedures will not be described in specific maintenance sections.

GENERAL REMOVAL INSTRUCTIONS

1. **Work Required.** Remove only those parts needing repair or replacement. Do not disassemble a component any further than needed.
2. **Preparation.** Before removing any part of the electrical, hydraulic, or air systems, make certain system is not energized or pressurized. Disconnect battery cables. Relieve all pressure from air system. Make sure brakes are locked and that all controls are in OFF position before starting any removal procedure.
3. **Removal.** Make sure there is enough clearance to remove part. Disassemble adjacent parts as needed to provide working clearance.
4. **Lifting.** Always use chain hoist, jack, or other aid when lifting heavy parts. Make certain load limit of lifting device exceeds weight being lifted. Position and rig lifting device before disconnecting part for removal.
5. **Identification.** Tag or mark all similar parts, such as electrical leads, before disconnecting and removing such parts. This will make proper assembly easier. Be sure to identify mating 'ends of electric lines, hydraulic lines, and air tubes as they are disconnected.
6. **Position of Valves.** Before removing valve handles, mark or diagram their positions when open and closed. This will help during assembly,

GENERAL DISASSEMBLY INSTRUCTIONS

1. **Cleanliness.** Work area must be kept as clean as possible. This will prevent injury or contamination of internal parts. This is especially true for valves, cylinders, and other hydraulic or air system parts.
2. **Expendable Pads.** As indicated in this manual, all gaskets, packings, and seals removed during repair must be discarded and replaced with new parts. These items are usually damaged during removal. In the same way, all lockwire, cotter pins, and like items must be replaced at time of assembly.
3. **Removing Seals.** When removing gaskets, packings, or seals, do not use any metal tool that will scratch the surfaces next to these items.
4. **Disassembly.** Before disassembly of any item, study the illustration carefully. Note relationship of internal parts. Knowing details of a component will speed up disassembly and assembly and will help avoid mistakes.
5. **Parts Protection.** To prevent moisture and dirt from entering open housings, lines, and other openings, apply protective caps and plugs as soon as possible after disassembly. Wrap all removed parts in clean paper or dip parts in preservative oil.

GENERAL CLEANING INSTRUCTIONS

WARNING

- Drycleaning solvent P-D-680 is toxic and flammable. Wear protective goggles and gloves and use only in a well-ventilated area. Avoid contact with skin, eyes, and clothes and do not breathe vapors. Do not use near open flame or excessive heat. The flash point is 100°-138°F (38°-50°C). If you become dizzy while using cleaning solvent, get fresh air immediately and get medical aid. If contact with eyes is made, wash your eyes with water and get medical aid immediately.
- Never use gasoline to clean parts. Gasoline is highly flammable. Serious personal injury could result if fuel ignites during cleaning.

CAUTION

- Petroleum solvents may damage parts that are in contact with hydraulic fluids.
- To prevent damage to equipment, do not clean tires, lubricant seals, rubber hoses, or electrical components with solvent mixture.

1. Cleaning Solvents. Use only approved cleaning solvents to clean parts. Drycleaning solvent SD-2 is commonly used. Always work in a well-ventilated area.

WARNING

To prevent injury, compressed air will not exceed 30 psi (207 kPa). Use only with effective chip guarding and personal protective equipment (goggles/shield, gloves, etc.).

2. Removing Deposits. After soaking parts in solvent, wash away deposits by flushing or spraying. Where necessary, brush with a soft-bristle brush moistened in solvent. Use compressed air to dry all parts, except bearings. Bearings must be allowed to air dry.
3. Tools. Do not use abrasive wheels, or compounds in cleaning parts, unless called for in detailed instructions. These procedures may weaken a highly stressed part.
4. Ball and Roller Bearings. When cleaning ball or roller bearings, place them in a basket and suspend them in a container of drycleaning solvent. If needed, use a brush to remove bearing before solid particles are removed to prevent damaging races and balls. When bearings have been cleaned, coat them lightly with lubricating oil to remove solvent. Refer to TM 9-214 for additional instructions on cleaning bearings.
5. Rubber Parts. Do not clean O-rings or other rubber parts in drycleaning solvent. Clean by washing with a mild solution of soap and water. Wipe with a clean, dry, lint-free cloth.

WARNING

Steam cleaning creates hazardous noise levels and severe burn potential. Eye, skin, and ear protection are required.

6. Exterior Parts. Steam clean all exterior parts thoroughly before removing. This will make inspection and disassembly easier.

WARNING

Drycleaning solvent P-D-680 is toxic and flammable, Wear protective goggles and gloves and use only in a well-ventilated area, Avoid contact with skin, eyes, and clothes and do not breathe vapors. Do not use near open flame or excessive heat, The flash point is 100°-138°F (38°-50°C). If you become dizzy while using cleaning solvent, get fresh air immediately and get medical aid. If contact with eyes is made, wash your eyes with water and get medical aid immediately.

7. Engine, Cab, and Body. Use a spray gun and solvent mixture for cleaning exterior of engine, cab, and body. Allow mixture to remain on item surface for about 10 minutes before rinsing. Rinse with hot water under 80-120 pounds of pressure, if available. An ordinary garden hose with nozzle may be used if other equipment is not available. Rinse thoroughly.
8. Decreasing Machine. A decreasing machine may be used to remove heavy grease and oil accumulations from metal parts.
9. Passages. After removing parts from decreasing machine, and before coating with rust preventive, check all oil passages and cavities for dirt or blockage. A thin, flexible wire should be run through oil passages to make certain they are not clogged. Individual passages that are dirty may be cleared using a pressure spray gun and drycleaning solvent.

CAUTION

To prevent corrosion, parts should be dipped in rust preventive compound within 2 hours after decreasing.

10. Electrical Parts. Electrical parts, such as coils, junction blocks, switches, and igniters, which use insulating materials, should not be soaked or sprayed with cleaning solutions. Clean these parts with a clean, lint-free cloth moistened with drycleaning solvent.
11. Electrical Grounds. Clean electrical ground contacts with crocus cloth.
12. Oil and Fuel Tank. Pay special attention to all warnings and cautions when working on vehicle's fuel tank. Oil tanks and fuel tanks should be flushed, using a spray gun and drycleaning solvent.
13. Battery. Exterior surfaces of the electrical system and battery should be cleaned with a weak solution of baking soda and water. Apply solution with a bristle brush to remove any corrosion.

GENERAL CLEANING INSTRUCTIONS (CONT)

CAUTION

To prevent damage to equipment, never use gasoline or other petroleum-base products to clean or preserve hydraulic system parts.

14. Hydraulic System. When cleaning hydraulic system parts, use drycleaning solvent SD-2. Clean and dry parts thoroughly to make sure no residue remains. If a coating of preservative is required before assembly, apply a light film of preservative oil. If petroleum-free solvents are not available, use the same hydraulic fluid as used in the hydraulic system.

GENERAL INSPECTION INSTRUCTIONS

1. Sealing Surfaces. Inspect all surfaces in contact with gaskets, packings, or seals. Make sure there are no nicks, burrs, or scratches. If any defect is found, remove or repair it as outlined under General Repair Instructions in this chapter.
2. Bearings. Check bearings for rusted or pitted balls, races, or separators. Check balls and races for brinnelling, abrasion, and serious discoloration. Refer to TM 9-214 for additional instructions for bearings. Following are causes for bearing rejection:
 - Cuts or grooves parallel to ball or roller rotation.
 - Fatigue pits (not minor machine marks or scratches).
 - Cracks.
3. Inspection. Inspection consists of checking for defects such as distortion, wear, cracks, and pitting. Parts under heavy load or pressure must be inspected more thoroughly. Clean all parts before inspection.
4. Drain Plugs. When removing drain plugs from transmission, engine, or hydraulic system components, inspect sediment adhering to plug. A buildup of grit and/or fine metal particles may indicate part failure. A few fine particles are normal. This inspection is effective in determining defective parts prior to internal inspection of parts.
5. Gears. Gear inspection cannot be described in detail here; there are too many differences in size and shape of gears. The following steps can be used to make a general visual inspection of all gears. Follow all steps listed in General Repair Instructions for final inspection.
 - Normal Wear. Loss of metal from the surface of gear teeth. Wear must not prevent gears from meshing or performing properly.
 - Initial Pitting. This may occur when a pair of gears is first started in service. It may continue until most high spots have been reduced, as long as contact surfaces are not affected. This pitting is not necessarily serious.
 - Destructive Pitting. This type of pitting occurs after initial pitting, often at an increasing rate. This will destroy contact area and reduce the gear's ability to carry a load. Rapid destruction will occur with use.

- Abrasive Wear. This damage is caused by the fine particles that may come from many sources: metal detached from gear teeth or bearings, abrasives not completely removed before assembly, sand or scale from castings, or other impurities in oil or air.
 - Scoring. Slight scoring, scuffing, galling, or other surface damage is identified by tears or scratches in the direction of sliding. It starts in areas having the highest stress and speed. This is usually at the tip of the teeth.
 - Burning. Burning is indicated by discoloration and loss of hardness due to excessive temperature. This is caused by too much friction resulting from overload, overspeed, lack of backlash, or faulty lubrication. If discoloring can be wiped off with clean cloth, such discoloring usually can be traced to oilburn-trains, which are not serious.
 - Roiling. This damage occurs mainly on plastic gears. Roiling is when material is pushed out of shape without breaking off. This is caused by heavy, even loads; sliding; or overheating.
 - Brinelling. This can be identified by tiny indentations or ridges on the shoulder or race of a bearing.
6. Splines. inspect shaft splines for wear, pitting, rolling, peening, and fatigue cracks. In many cases, the same inspection procedure will apply to gears. However, the problem, if present, will often be much less pronounced. Have a magnetic particle inspection performed on splines, if needed.
 7. Tubes and Hoses. Check all hose surfaces for broken or frayed fabric. Check for breaks caused by sharp kinks or rubbing against other parts of the truck. Inspect air tubes for kinks. inspect the fitting threads for damage. Replace any part found defective. Following assembly and during initial operation, check for leaks.
 8. Electrical Parts. inspect all wiring harnesses for chafed or burned insulation. Inspect all terminal connectors for loose connections and broken parts.
 9. Metal Parts. Visually inspect ail castings and weldments for cracks. Paris that carry a great load should receive magnetic particle inspection. Critical nonferrous parts may be inspected with fluorescent penetrant.

GENERAL REPAIR INSTRUCTIONS

WARNING

Drilling and grinding operations are hazardous to the eyes. Eye protection is required.

1. Burrs. Remove burrs from gear teeth with a fine-cut file or hand grinder. Remove burrs on closely fitted mating surfaces by lapping the surfaces with abrasive-grade compound.
2. Exterior Parts. Chassis and exterior painted parts may be resurfaced where paint is damaged, or where parts have been repaired, by using an abrasive disc driven by a flexible shaft. Paint metal surfaces as required per TM-9-2320-363-10.
3. Bearings. Remove residue and oil stain from bearing races with crocus cloth.

GENERAL REPAIR INSTRUCTIONS (CONT)

NOTE

The following procedure is used with polished and machined steel parts not protected by cadmium, tin, copper, or other plating or surface treatment. Bare metal surfaces must be free of moisture when protective coating is applied.

4. Protective Parts. During repair operations, protect bare steel surfaces from rusting when not actually undergoing repair work. Dip parts in, or spray them with, corrosion preventive compound. The same protective coating may be applied to other metals to prevent rust. Aluminum parts may require protection in atmospheres having a high salt content. Steel parts must always be protected.

CAUTION

Before welding, the following components must be disconnected: DDEC ECU, ABS ECU, CTIS ECU, DATALOGGER, and batteries (TM 9-2320-363-20-2). If welding on a trailer, it must be uncoupled from tractor/dump truck. Failure to follow this caution may damage electronic components.

5. Welding. Welding and brazing may be used to repair cracks in external steel parts, such as brackets, panels, and light framework. These repairs should be made only when replacement parts are not available. Do not weld or braze castings, running parts, or parts under great stress, except in emergencies. When welding is required, refer to TM 9-237.
6. Stud Installation. When installing studs in engine block and axle housings, use a driver designed for the stud to be installed. A worn stud driver may damage the end thread. This makes it necessary to use a chasing die before a nut can be screwed on. This procedure will remove cadmium plating and allow corrosion, which will make future disassembly difficult and cause stud to be backed out with nut. Before driving a stud, inspect hole for chips and liquid. Blow out any foreign matter. Start stud by hand. If it will not start into hole, it is too large or has defective end thread. Before final insertion, coat thread with antiseize compound; turn stud in slowly to prevent overheating and galling of casting metal.
7. Electrical Parts. Replace all broken, worn, or burned electrical wiring. Wires with several broken strands must be replaced. Broken strands will increase the resistance of the wire and impair efficiency of electrical components, especially the ignition system.
8. Hoses. Replace all broken, frayed, crimped, or soft flexible lines and hoses. Replace stripped or damaged fittings. Replace entire flexible hose if fittings are damaged. Make sure hose clamps do not crimp hoses.
9. Fasteners. Replace any bolt, screw, nut, or fitting with damaged threads. Inspect tapped holes for thread damage. If cross-threading or galling is evident, retap the holes for the next oversize screw or stud. When retapping will weaken the part, or when the cost of the part makes retapping impractical, replace the damaged part. Chasing threads with the proper size tap or die may often be enough.
10. Dents. Straighten minor body dents by bumping with a soft-faced hammer while using a wooden block backing.
11. Sheet Metal Repair. Repair minor skin cracks by installing patches.
12. Mounting Holes. Reshape oval mounting holes to round. Drill to receive bushing with required inner diameter. Stake bushing in place with center punch.

GENERAL ASSEMBLY INSTRUCTIONS

1. Preparation. Remove grease from new parts before installation.

2. Packing Installation. Lubricate ail packings with a thin coating of light mineral oil before installation. Slightly stretch packing and place into position. Rotate component on flat surface or uniformly press the packing into position.
3. Pipe Joints. Use nonhardening pipe-joint compound or thread sealing tape when joining piping.
4. Gaskets. To provide added sealing for gasket, coat both sides with sealant. Remove all traces of previous gasket and sealant before installing new gasket.
5. Silicone Sealant.

WARNING

On direct contact, uncured silicone sealant irritates eyes. In case of contact, flush eyes with water and seek medical attention. Avoid prolonged contact with skin.

Silicone sealant is often used instead of a gasket to seal mating parts. Mating parts must be clean, dry, and free of oil or grease for proper adhesion. After silicone sealant has been applied, mating parts must be assembled within 15 minutes. Silicone sealant starts to set up in 15 minutes and takes 24 hours to completely cure. Excess silicone sealant should be wiped off after assembling mating parts.

6. Oil Seals. install oil seals with seal lip facing toward lubricant, applying an even force to outer edge of seal. Coat oil seals evenly with grease before installing. If oil seals will be installed over keyed or splined shafts, use a guide. This will prevent sharp edge of keyway or splines from cutting the leather or neoprene seal. Construct guides of very thin-gage sheet metal and shape to required diameter. However, make certain guide edges are not sharp. Bend them slightly inward so they do not cut the seal.
7. Seal Rings. Coat seal rings with oil and carefully install into their bores. If seal rings must be installed over threaded parts, temporarily wrap the threads with tape to protect the seal ring; then remove the tape.
8. Bearings and Shafts. During assembly of shafts and bearings in housings, first mount bearing on shaft, then install the assembly by applying force to shaft. When mounting bearings on shafts, always apply force to the inner races of the bearing.
9. Bearing Lubrication. Lubricate bearings before reassembly with the type of lubricant normally used in the related housing or container. This will provide lubrication during the first run-in until lubricant from the system can reach the bearings.

GENERAL INSTALLATION INSTRUCTIONS

1. Preparation. Before installing any parts, make sure they are clean and that both mounting surfaces are clean and free of oil and grease (unless otherwise noted).
2. installation. Make sure there is enough clearance to install part. Disassemble adjacent parts as needed to provide working clearance.

GENERAL ASSEMBLY INSTRUCTIONS (CONT)

3. Lifting. Always use chain hoist, jack, or other aid when lifting heavy parts. Make certain load limit of lifting device exceeds weight being lifted. Position and rig lifting device before connecting part for installation.

GENERAL LUBRICATION INSTRUCTIONS

Keep light coat of lubricating oil (PL-medium or PL-special) on parts during repair procedures to prevent rusting. Lubricate parts during the repair and assembly as required by TM 9-2320-363-20, Unit PMCS.

GENERAL TORQUE VALUE INSTRUCTIONS

Use the torque values listed in the maintenance procedures, if they are given. When no torque values are given in the maintenance procedures, refer to the torque value guide in Appendix D.

**CHAPTER 3
POWER PACKAGE MAINTENANCE**

OVERVIEW

This chapter illustrates and describes procedures for maintenance of the power package.

Section I. Engine Assembly and Related Parts Removal and Installation	3-2
Section II. Transmission and Transfer Case Removal and Installation	3-234



**Section I. ENGINE ASSEMBLY AND RELATED PARTS
REMOVAL AND INSTALLATION**

OVERVIEW

This section illustrates and describes procedures for removal and installation of the engine assembly and related parts. A list of tasks contained in this section is shown below.

	Page
Engine Replacement	3-4
Front Engine Mount Adapter Replacement	3-46
Rear Engine Mounts Replacement (M915A2)	3-48
Rear Engine Mounts Replacement (All Except M915A2)	3-52
Fan Drive Support Replacement	3-56
Air Intake Manifold Replacement (M915A2 and M916A1)	3-61
Air Intake Manifold Replacement (All Except M915A2 and M916A1)	3-66.1
Exhaust Manifold Replacement (M915A2 and M916A1)	3-67
Exhaust Manifold Replacement (All Except M915A2 and M916A1)	3-70.1
Rocker Cover Replacement	3-71
Breather Tube Replacement	3-78
Cylinder Head Replacement	3-80
Air Compressor Drive Replacement and Repair	3-92
Turbocharger Replacement	3-101
Injector Replacement	3-108
Injector Solenoid Repair	3-114
Gear Case Cover Replacement	3-116
Vibration Damper Replacement	3-122
Accessory Drive Replacement	3-126
Engine Retarder Replacement and Repair	3-129
Crankshaft Rear Oil Seal Replacement	3-141
Crankshaft Oversize Rear Oil Seal Replacement	3-145
Flywheel Housing Replacement	3-148
Flex Plate Replacement and Repair	3-154
Camshaft and Bearings Replacement	3-162
Rocker Arm Assemblies Replacement	3-183
Oil Pump Replacement and Repair	3-199

	Page
Oil Relief Valve and Oil Regulator Valve Replacement	3-216
Oil Pan Replacement	3-220
Crankshaft Front Oil Seal Replacement	3-227
Crankshaft Oversize Front Oil Seal Replacement	3-231

ENGINE REPLACEMENT

This task covers: a. Removal b. Cleaning c. Inspection d. Installation

INITIAL SETUP

Tools and Special Equipment:

Shop Equipment, SC 4910-95-CL-A31
 Tool Kit, SC 5180-90-CL-N05
 Shop Equipment, SC 5180-95-CL-A62
 Load Rotor, J 36130-812
 Spreader, 38841

Materials/Parts:

Washer, Lock
 Clamp, Seal P/N KYXOO-5833
 Nut, Lock (7)
 Washer, Lock (12) P/N 103323
 Washer Lock (3)
 Washer, Lock (6)
 Tie, Wire

Personnel Required: (2)

References:

TM 9-2320-363-20

Equipment Condition:

Reference	Condition Description
TM 9-2320-363-20	Engine Oil Drained
TM 9-2320-363-20	Air System Drained
TM 9-2320-363-20	Transmission Tunnel Access Cover Removed
TM 9-2320-363-20	Hood Removed
TM 9-2320-363-20	Fan Impeller and Shroud Removed
TM 9-2320-363-20	Air Intake Tubes, Hoses, and Clamps Removed
TM 9-2320-363-20	Air Cleaner, Pre-Cleaner, and Duct Assembly Removed
TM 9-2320-363-20	Alternator/Air Conditioner Belt Removed

Equipment Description (Cont):

Reference	Condition Description
TM 9-2320-363-20	Alternator and Alternator Adjusting Rod Removed
TM 9-2320-363-20	Fender Extensions Removed
TM 9-2320-363-20	Oil Sample Valve Removed
TM 9-2320-363-20	STE/ICE Differential Switch Removed
TM 9-2320-363-20	Transfer Case Front Output Driveline Removed (All Except M915A2)
Page 11.1-9	Air Conditioner Compressor Removed

General Safety Instructions:

WARNING

- Do not place finger in hole of engine flywheel housing while engine is being barred over. To do so could result in serious injury to personnel.
- Transmission weighs 900 lb (409 kg). Support transmission with transmission jack during removal or installation to prevent possible injury to personnel.
- Do not place hands between engine and frame or engine and transmission. To do so could result in serious personal injury.
- Engine weighs 2,850 lb (1294 kg). Use hoist with lifting capacity of 5,000 lb (2270 kg) to lift and support engine. Failure to do so could result in injury to personnel.

REMOVAL

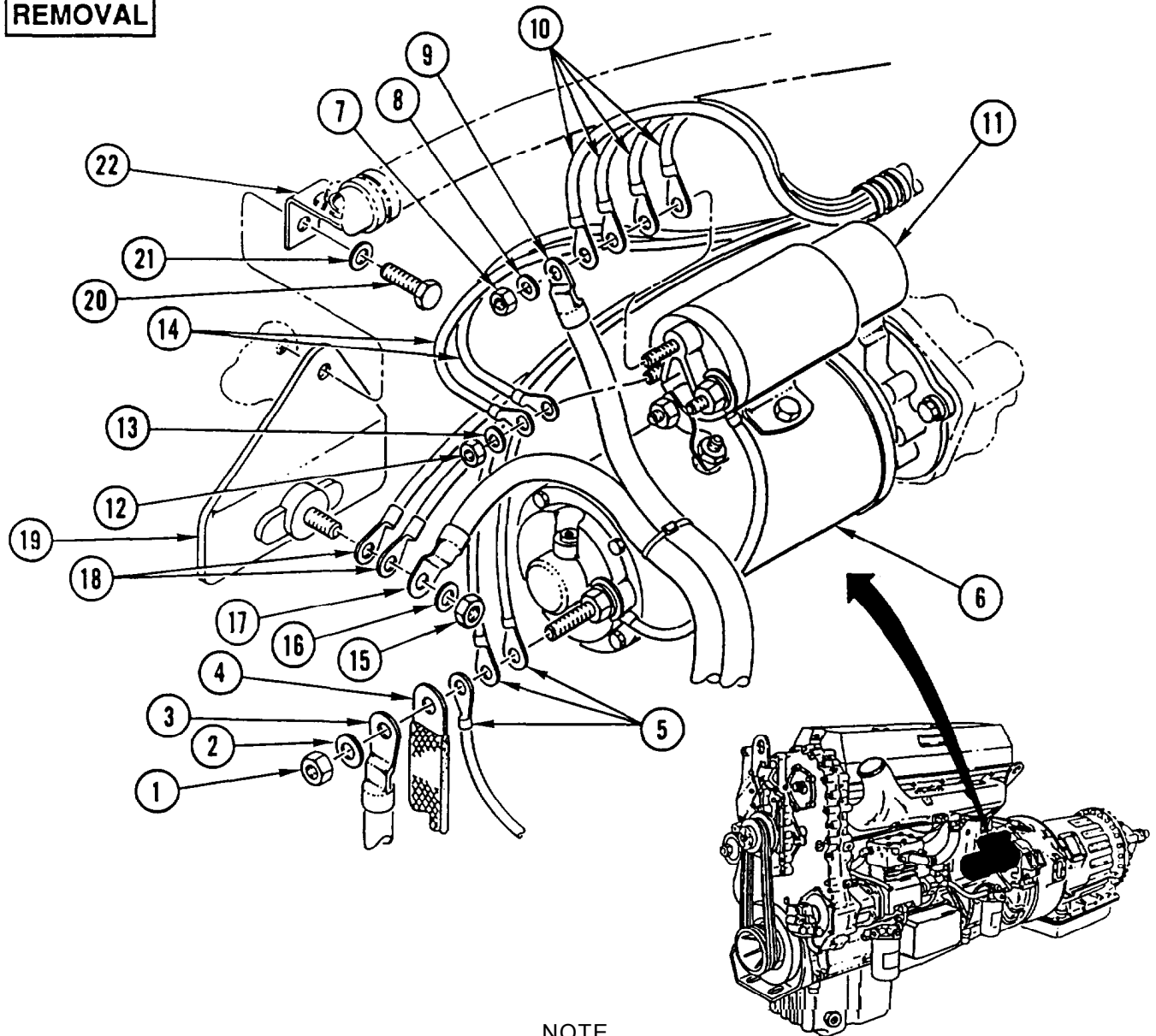

NOTE

Tag all wires, cables, connectors, hoses, and tubes prior to removal to aid in installation.

1. REMOVE NUT (1) AND WASHER (2) AND DISCONNECT CABLE (3), GROUND STRAP (4), AND THREE WIRES (5) FROM STARTER (6).
2. REMOVE NUT (7) AND WASHER (8) AND DISCONNECT CABLE (9) AND FOUR WIRES (10) FROM STARTER SOLENOID (11).
3. REMOVE NUT (12) AND WASHER (13) AND DISCONNECT TWO WIRES (14) FROM STARTER SOLENOID (11).
4. REMOVE NUT (15) AND WASHER (16) AND DISCONNECT CABLE (17) AND TWO WIRES (18) FROM PLATE (19).
5. REMOVE SCREW (20), WASHER (21), BRACKET (22), AND PLATE (19).

ENGINE REPLACEMENT (CONT)

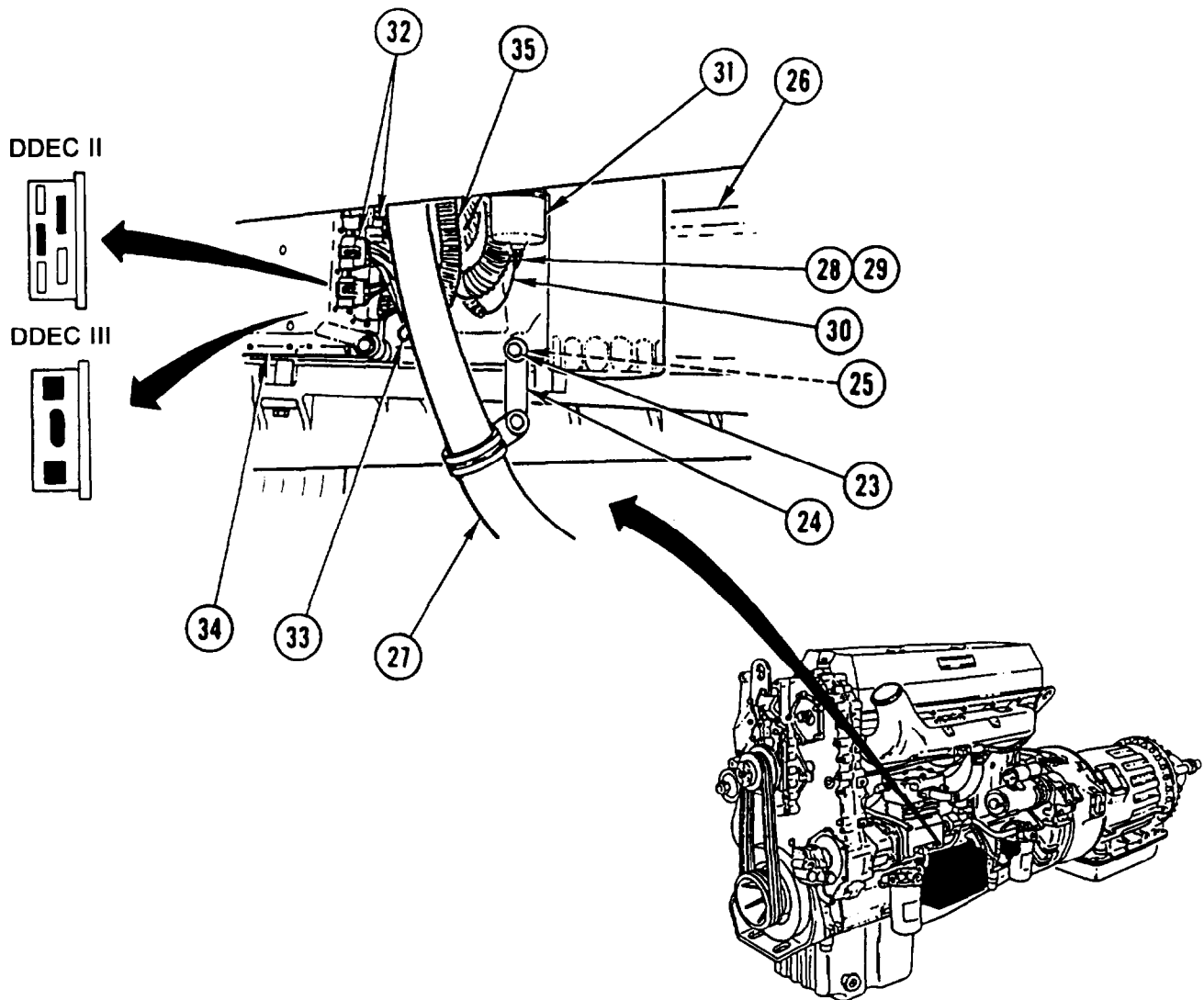

6. REMOVE SCREW (23), BRACKET (24), AND SPACER (25) FROM ENGINE BLOCK (26). SET CABLE HARNESS (27) ASIDE.
7. REMOVE NUT (28), WASHER (29), AND WIRE (30) FROM FUEL PRESSURE SENDING UNIT (31).
8. IF REMOVING A DDEC II EQUIPPED ENGINE, DISCONNECT TWO PLUGS (32) AND CONNECTOR (33) FROM DDEC II ELECTRONIC CONTROL MODULE (34). PULL HARNESS (35) OUT AND TIE TO CAB MOUNT.
 - 8.1 IF REMOVING A DDEC III EQUIPPED ENGINE, DISCONNECT DDEC III ELECTRONIC CONTROL MODULE HARNESS(ES) FROM CONNECTORS LOCATED AT REAR OF ECM.
 - 8.2 CUT TIE WRAPS AS REQUIRED TO FREE HARNESS FROM ENGINE.

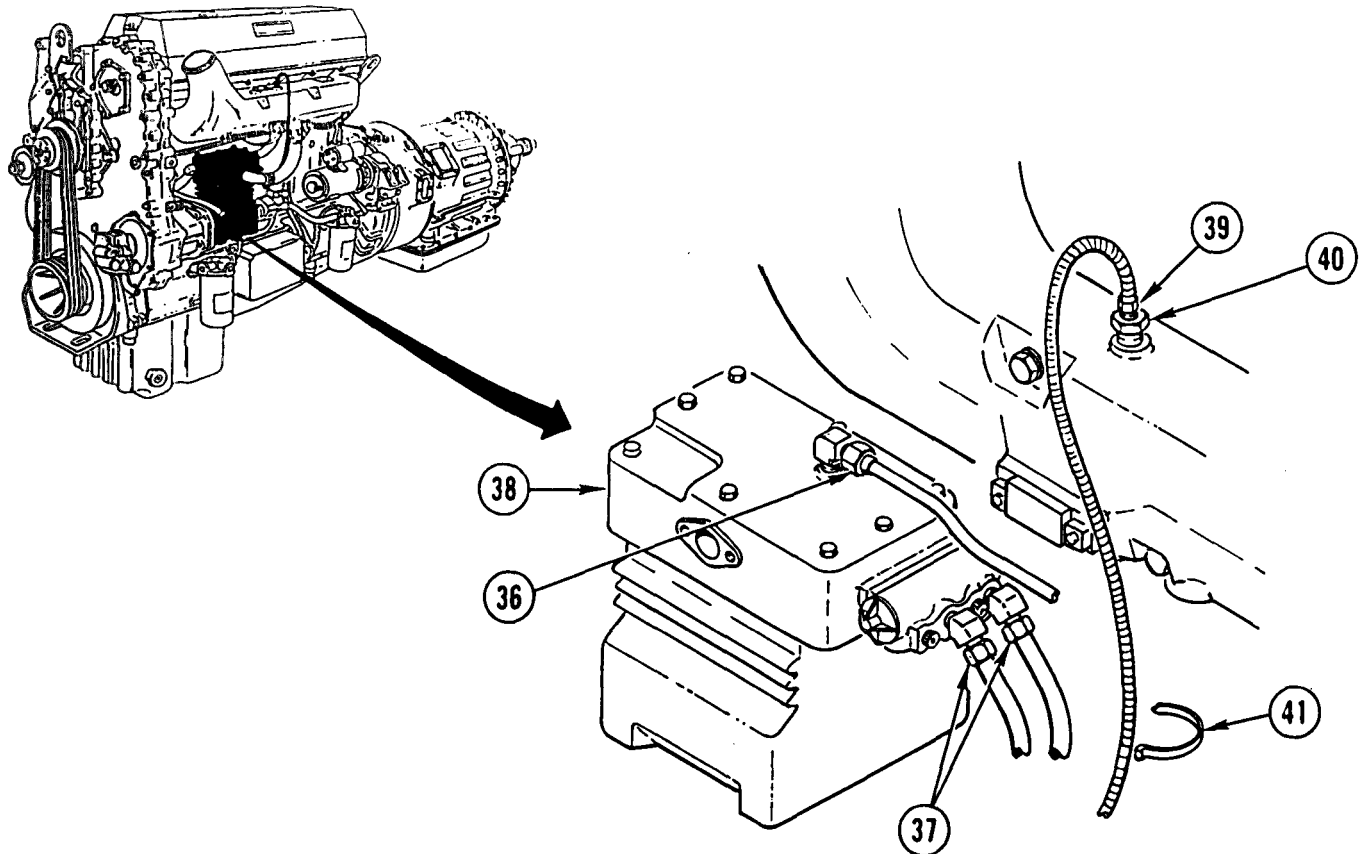

9. DISCONNECT HOSE (36) AND TWO TUBES (37) FROM AIR COMPRESSOR (38).
10. REMOVE TUBE (39), ATOMIZER (40), AND WIRE TIE (41). SET TUBE (39) AND TWO TUBES (37) ASIDE. DISCARD WIRE TIE.

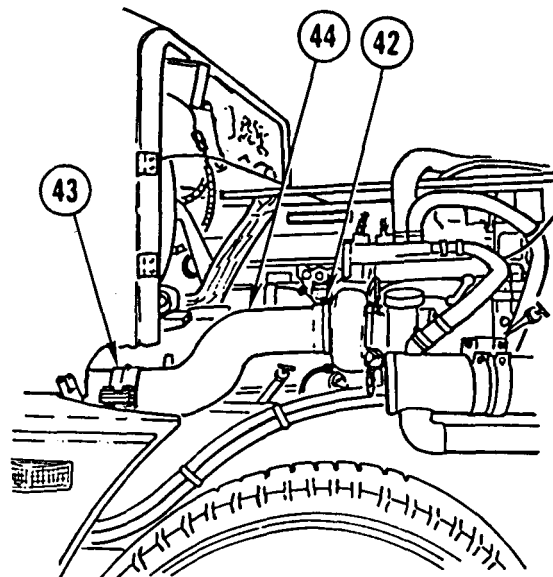

11. REMOVE CLAMP (42), SEAL CLAMP (43), AND EXHAUST PIPE (44). DISCARD SEAL CLAMP.

ENGINE REPLACEMENT (CONT)

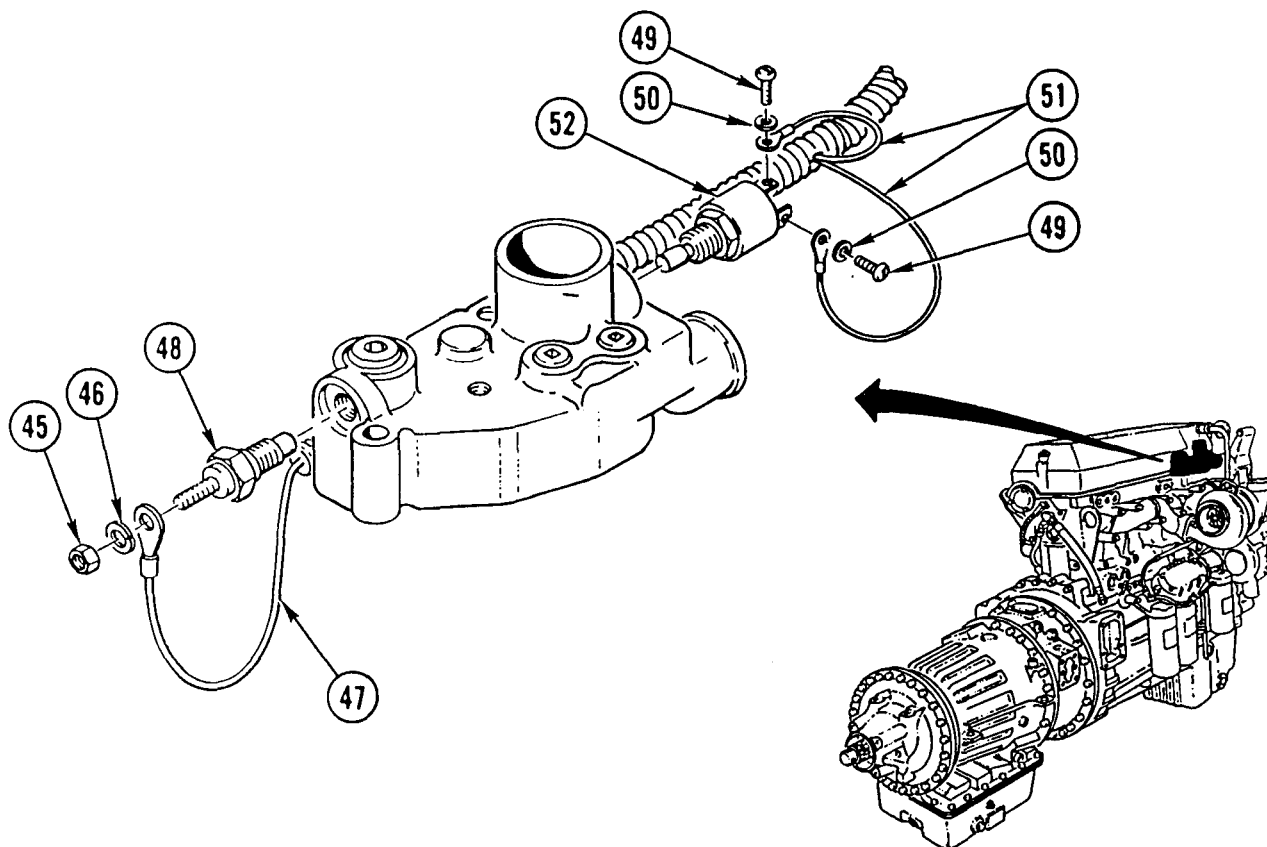

12. REMOVE NUT (45), LOCK WASHER (46), AND WIRE (47) FROM TEMPERATURE SENDING UNIT (48). DISCARD LOCK WASHER.
13. REMOVE TWO SCREWS (49), TWO LOCK WASHERS (50), AND TWO WIRES (51) FROM TEMPERATURE SENDING UNIT (52). DISCARD LOCK WASHERS.

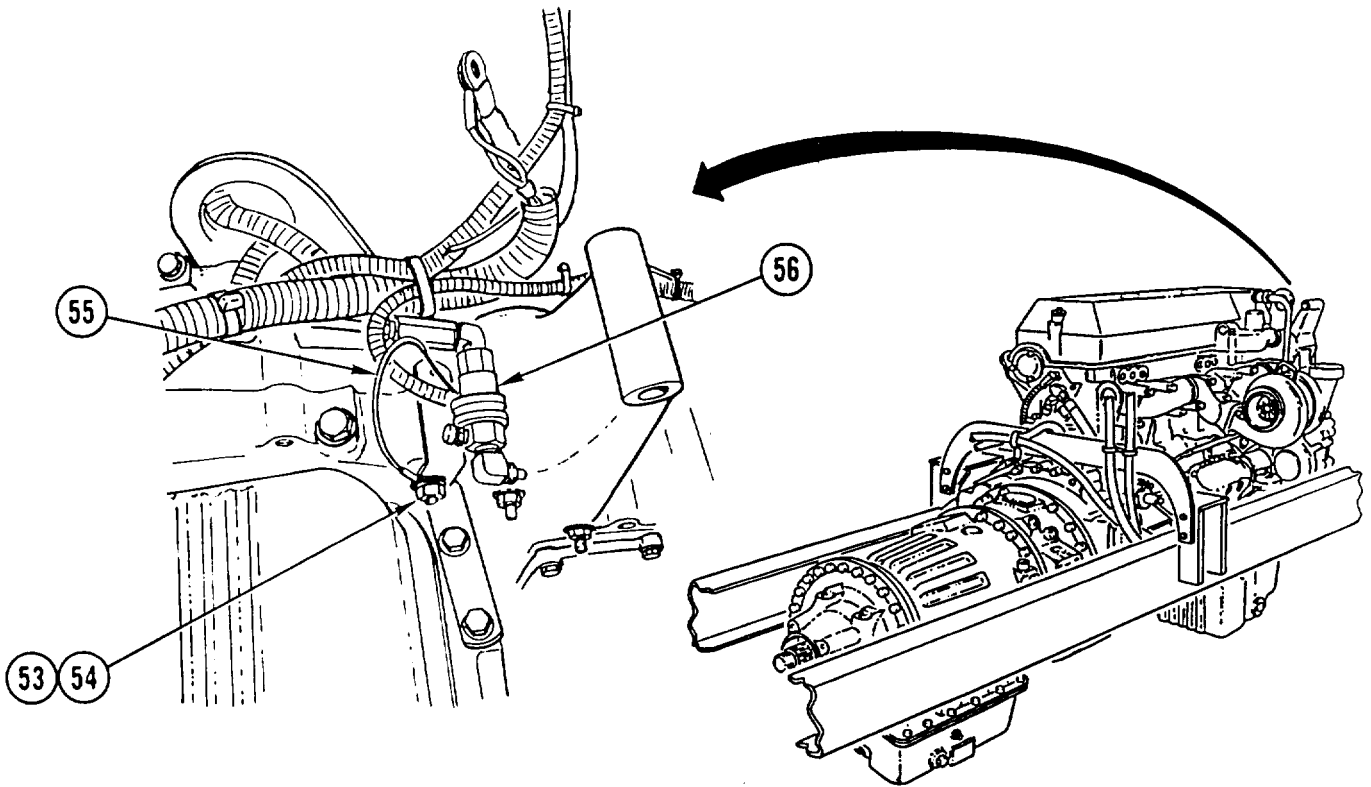

14. REMOVE NUT (53), WASHER (54), WIRE (55), AND SOLENOID (56). INSTALL NUT (53).

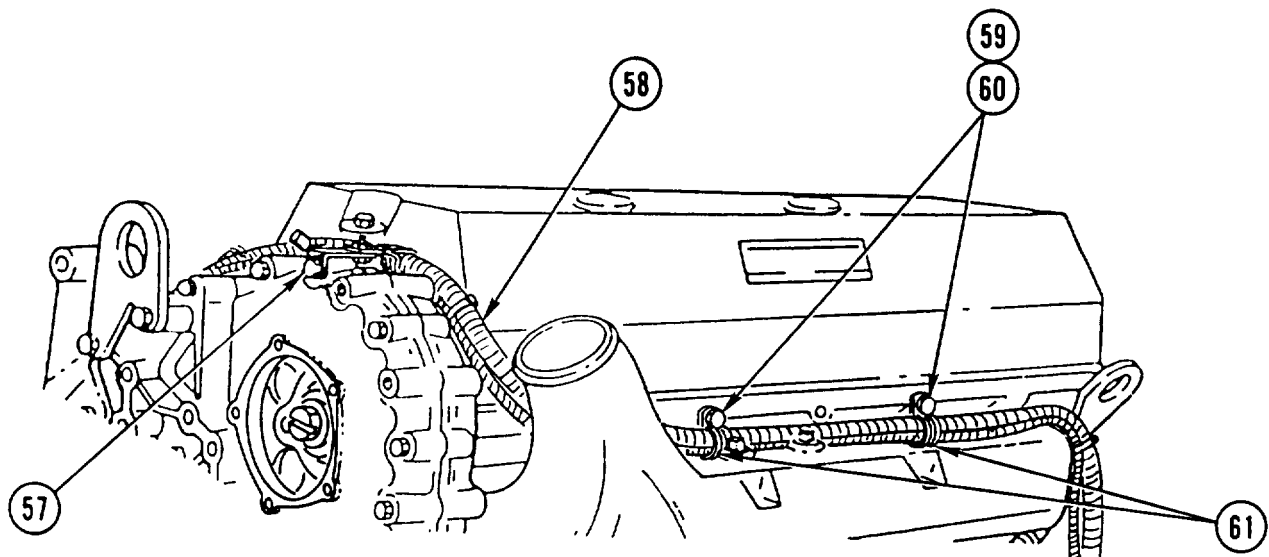

15. REMOVE SCREW (57) AND SET HARNESS (58) ASIDE. INSTALL SCREW (57).

16. REMOVE TWO SCREWS (59), TWO WASHERS (60), AND TWO CLAMPS (61). SET HARNESS (58) ASIDE.

ENGINE REPLACEMENT (CONT)

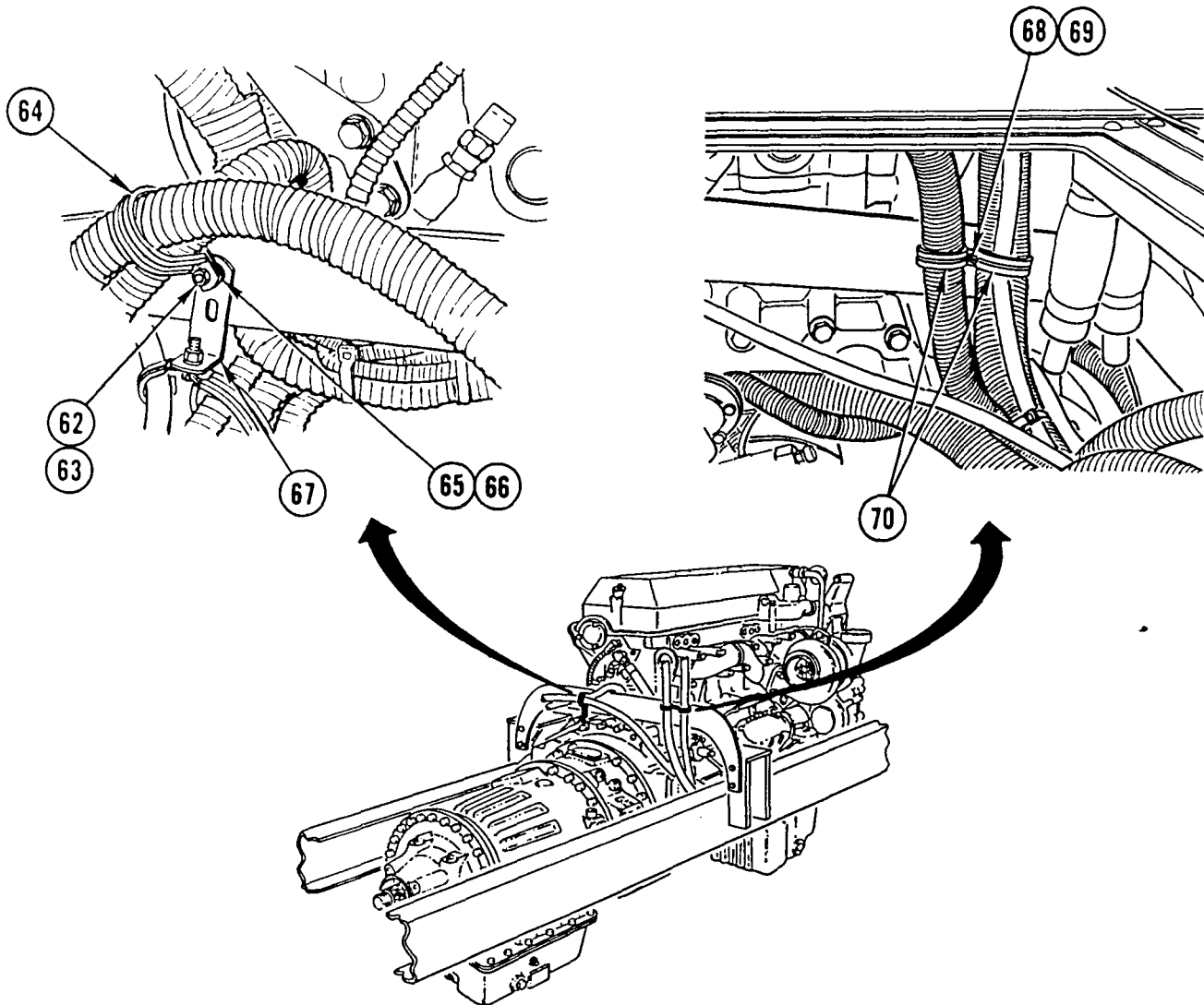

NOTE

Steps 17 thru 19 can be performed thru center floor panel of cab.

17. REMOVE LOCK NUT (62), WASHER (63), AND CLAMP (64). DISCARD LOCK NUT.
18. REMOVE LOCK NUT (65), WASHER (66), AND BRACKET (67). DISCARD LOCK NUT.
19. REMOVE LOCK NUT (68), WASHER (69), AND TWO CLAMPS (70). DISCARD LOCK NUT.

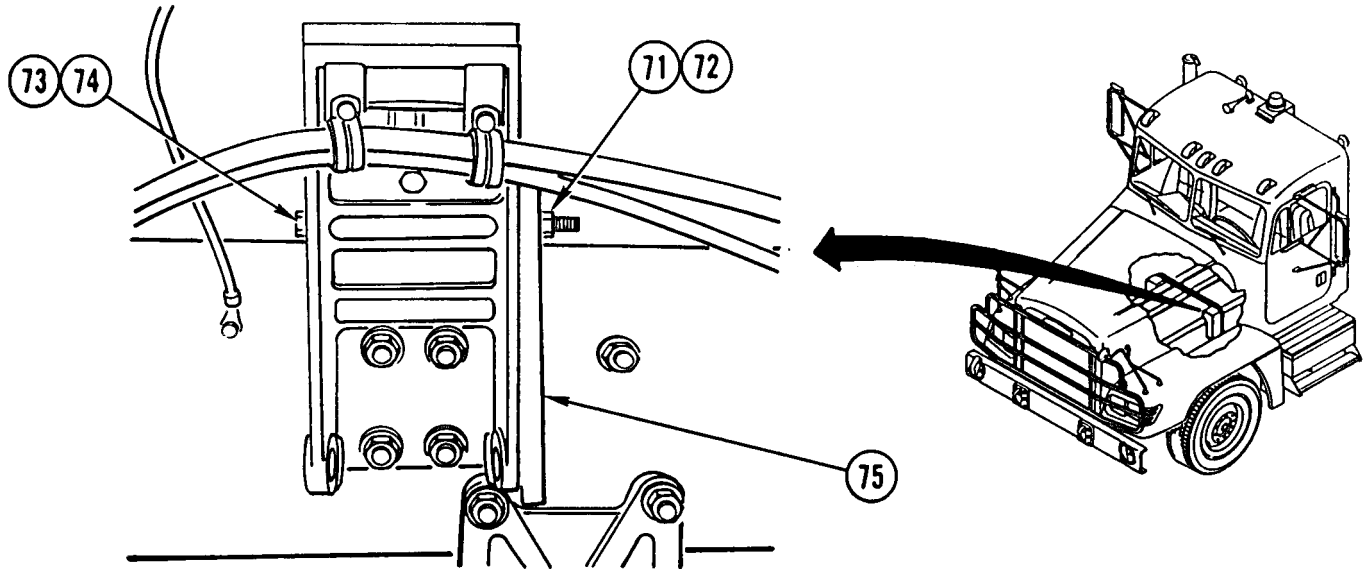

20. REMOVE NUT (71), WASHER (72), SCREW (73), AND WASHER (74) FROM LEFT END OF CROSSMEMBER (75).

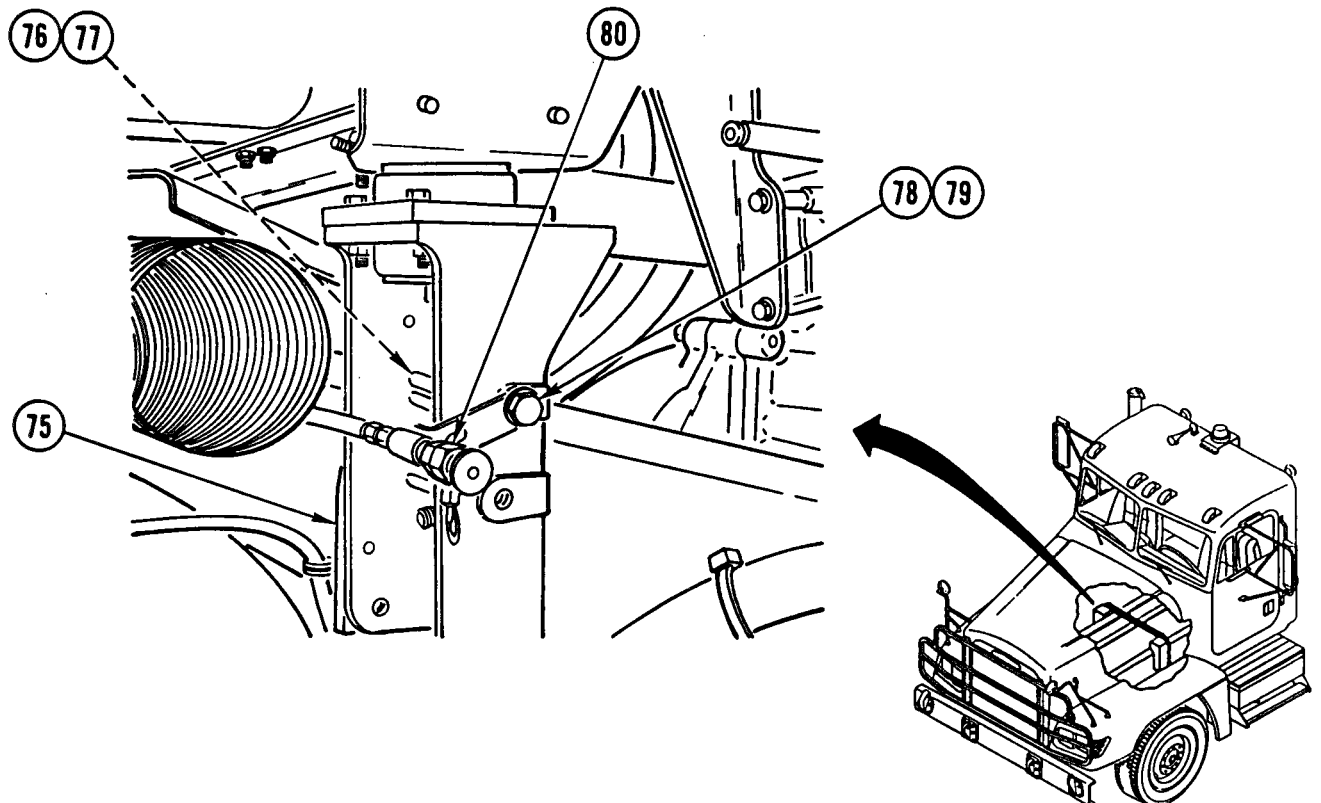

21. REMOVE NUT (76), WASHER (77), SCREW (78), AND WASHER (79). SET TRANSMISSION OIL SAMPLE VALVE (80) ASIDE AND REMOVE CROSSMEMBER (75).

ENGINE REPLACEMENT (CONT)

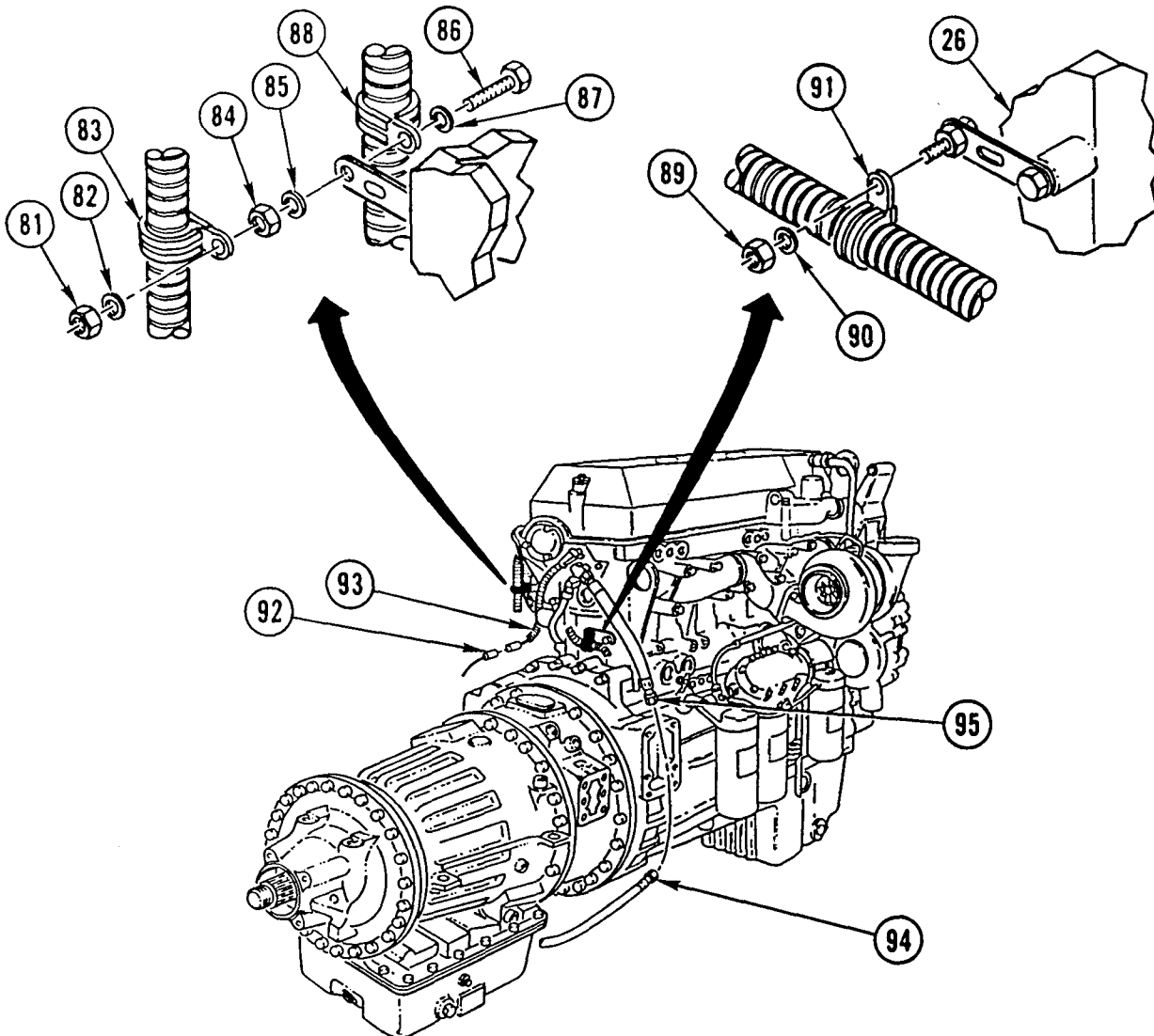

NOTE

Steps 22 thru 26 can be performed thru center floor panel of cab.

22. REMOVE LOCK NUT (81), WASHER (82), AND CLAMP (83), DISCARD LOCK NUT.
23. REMOVE LOCK NUT (84), WASHER (85), SCREW (86), WASHER (87), AND CLAMP (88). DISCARD LOCK NUT.
24. REMOVE LOCK NUT (89), WASHER (90), AND CLAMP (91) FROM REAR OF ENGINE BLOCK (26). DISCARD LOCK NUT.
25. DISCONNECT CONNECTOR (92) FROM ENGINE BRAKE HARNESS (93).
26. DISCONNECT FUEL RETURN HOSE (94) FROM HOSE (95). PLUG FUEL RETURN HOSE (94) AND SET ASIDE.

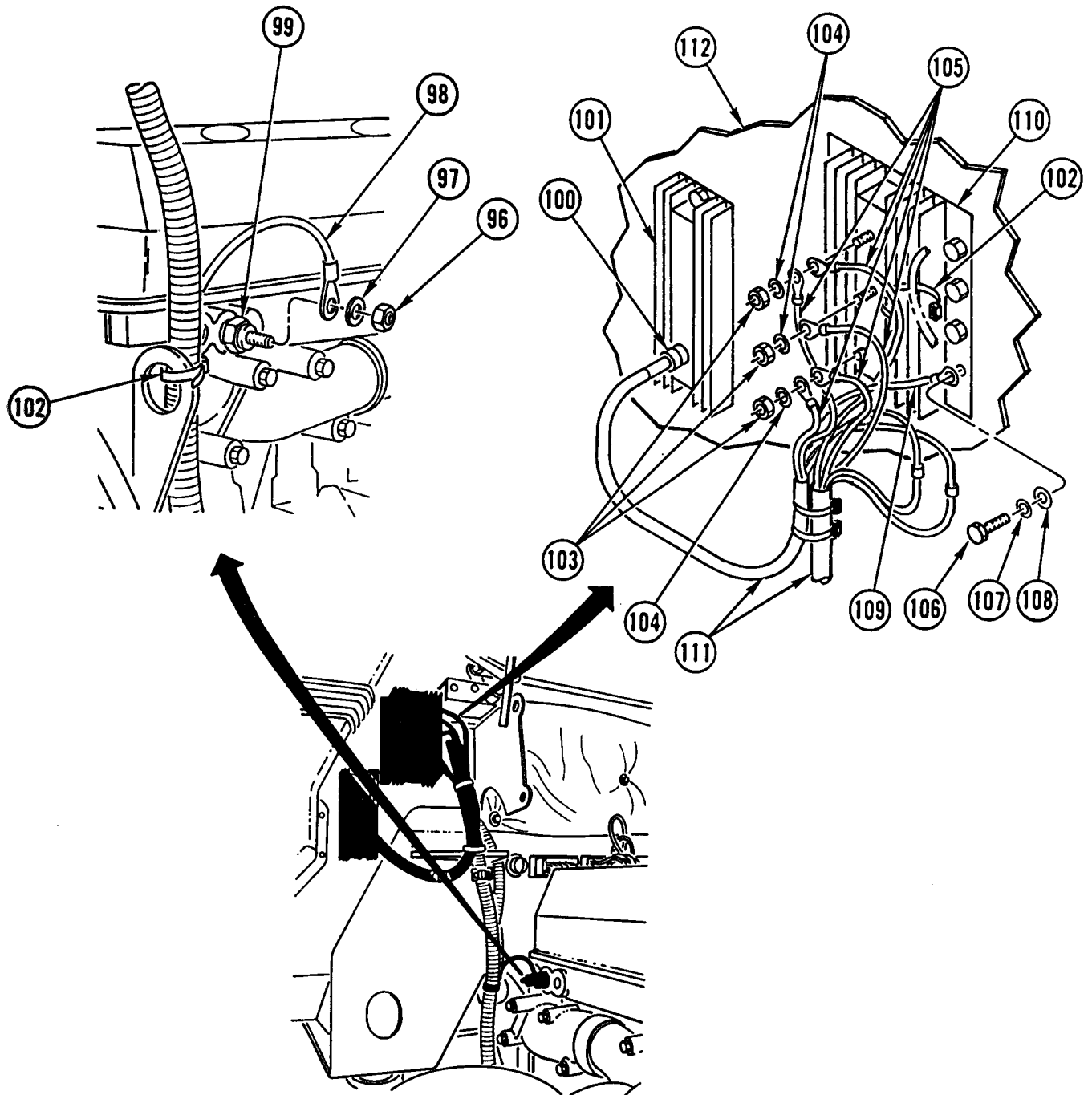

27. REMOVE NUT (96), LOCK WASHER (97), AND WIRE (98) FROM SENDING UNIT (99), DISCARD LOCK WASHER.
28. DISCONNECT PLUG (100) FROM VOLTAGE REGULATOR (101).
29. REMOVE TWO WIRE TIES (102), THREE NUTS (103), THREE WASHERS (104), AND FIVE WIRES (105).
30. REMOVE SCREW (106), LOCK WASHER (107), WASHER (108), AND GROUND WIRE (109) FROM DUAL VOLTAGE CONTROL (110). FEED HARNESS (111) UNDER CAB (112) AND OUT OF THE WAY. DISCARD LOCK WASHER.

ENGINE REPLACEMENT (CONT)

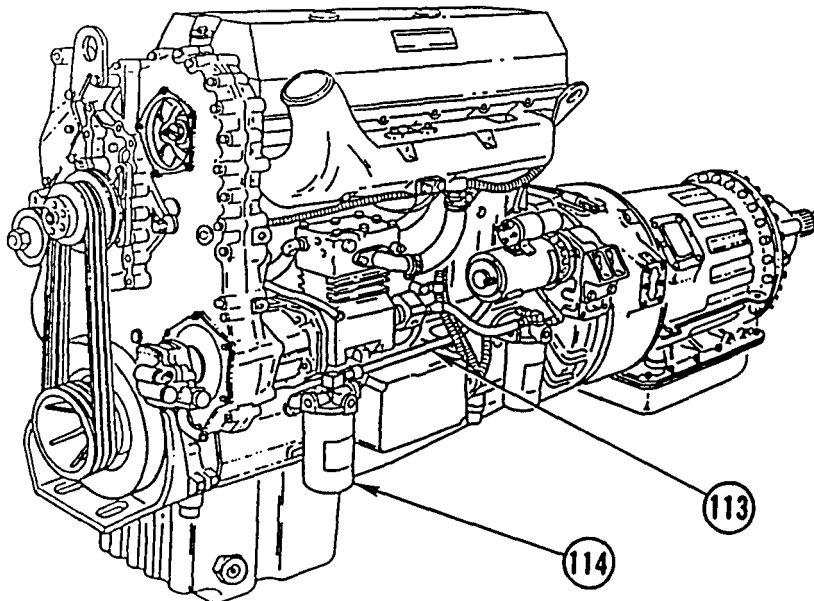

31. DISCONNECT FUEL HOSE (113) FROM PRIMARY FUEL FILTER (114). PLUG FUEL HOSE (113) AND SET ASIDE.

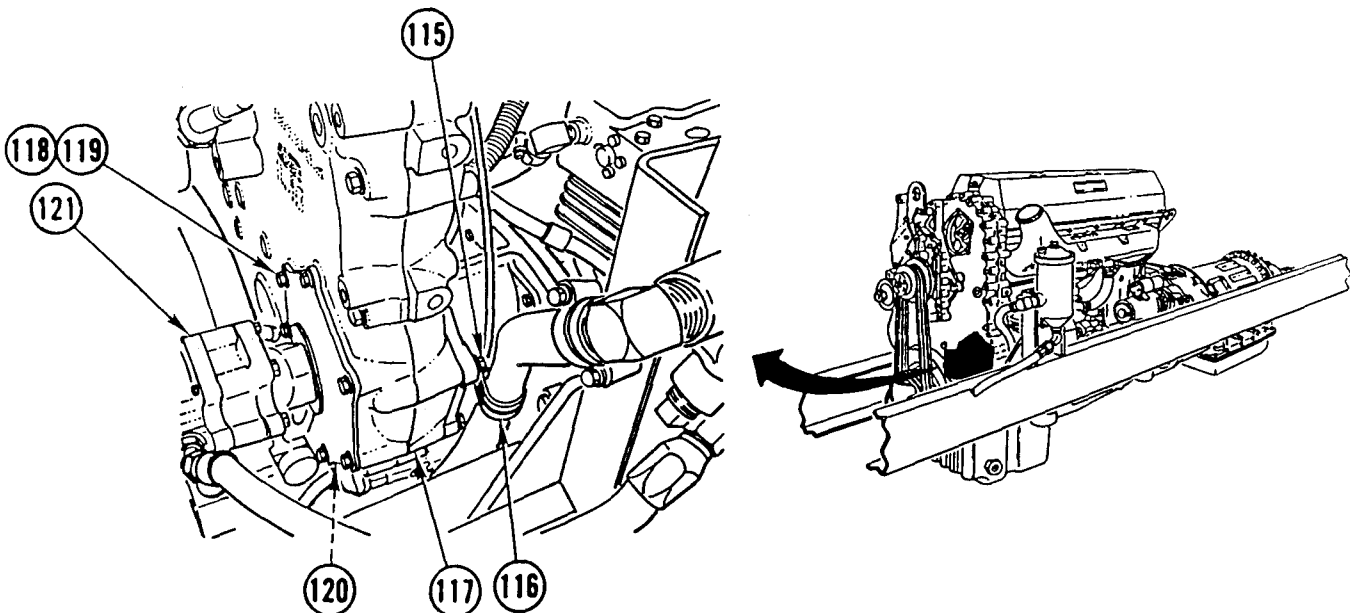

32. REMOVE SCREW (115) AND CLAMP (116) FROM GEAR CASE (117).

33. REMOVE SIX SCREWS (118), SIX LOCK WASHERS (119), DRIVE COUPLER (120), AND POWER STEERING PUMP (121). SET POWER STEERING PUMP (121) ASIDE. DISCARD LOCK WASHERS.

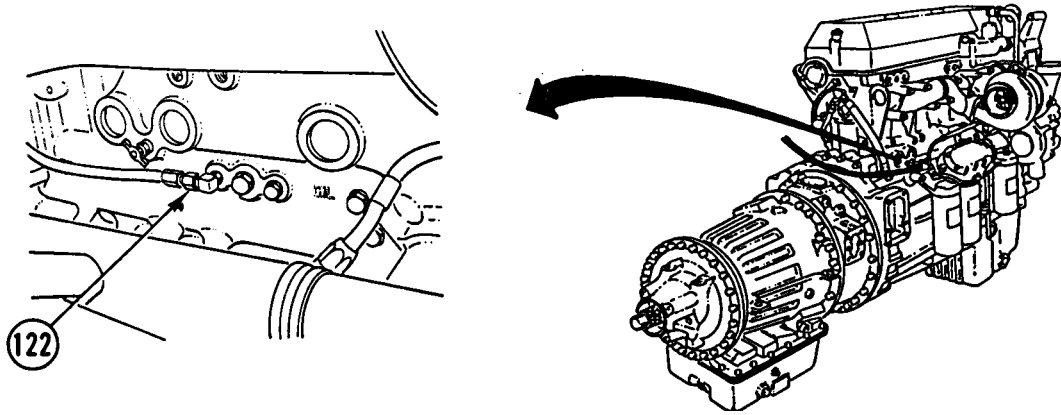

34. DISCONNECT AND PLUG OIL PRESSURE HOSE (122) AND SET ASIDE.

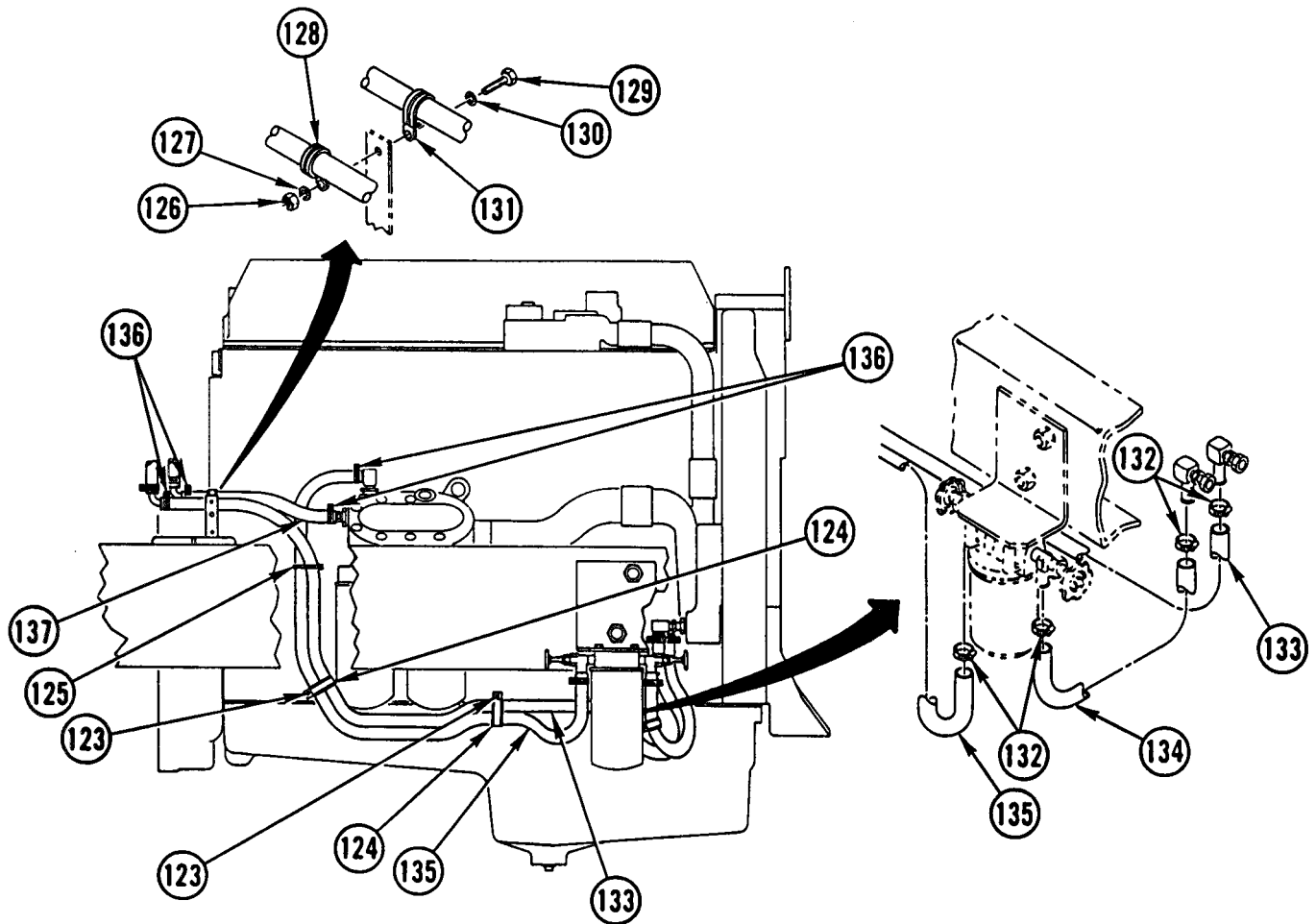

35. REMOVE TWO BOLTS (123), TWO WASHERS (124), AND TIE STRAP (125).
36. REMOVE LOCK NUT (126), WASHER (127), CLAMP (128), SCREW (129), WASHER (130), AND CLAMP (131). DISCARD LOCK NUT.
37. REMOVE FOUR CLAMPS (132) AND DISCONNECT THREE HOSES (133, 134, AND 135).
38. REMOVE FOUR CLAMPS (136) AND FOUR HOSES (133, 134, 135, AND 137).

ENGINE REPLACEMENT (CONT)

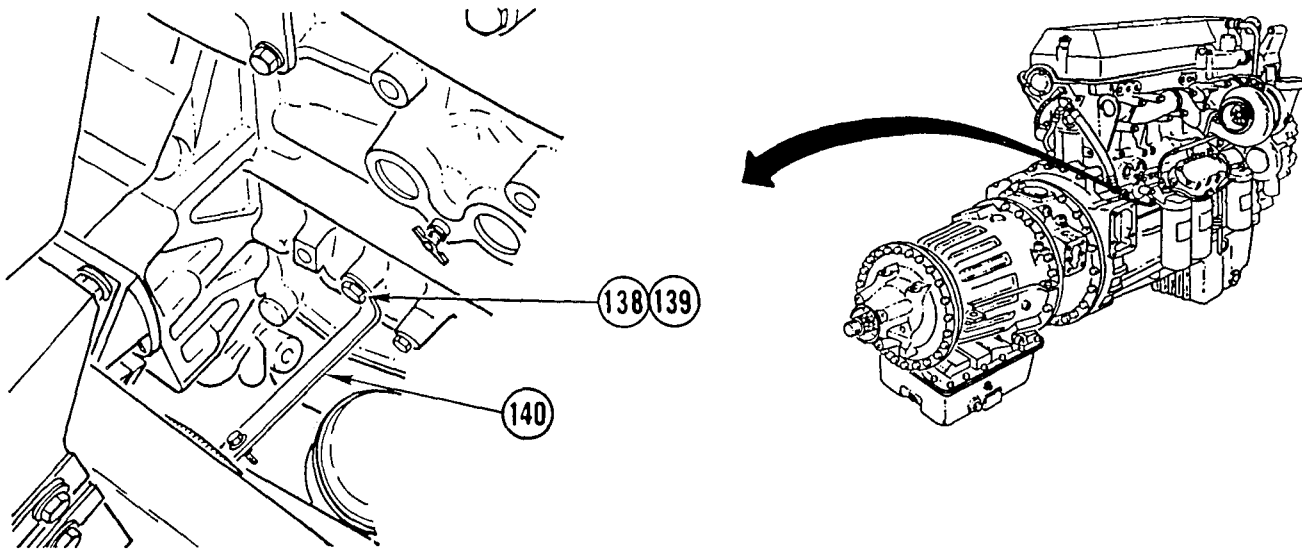

39. REMOVE SCREW (138) AND WASHER (139) AND ROTATE BRACKET (140) OUT OF THE WAY.

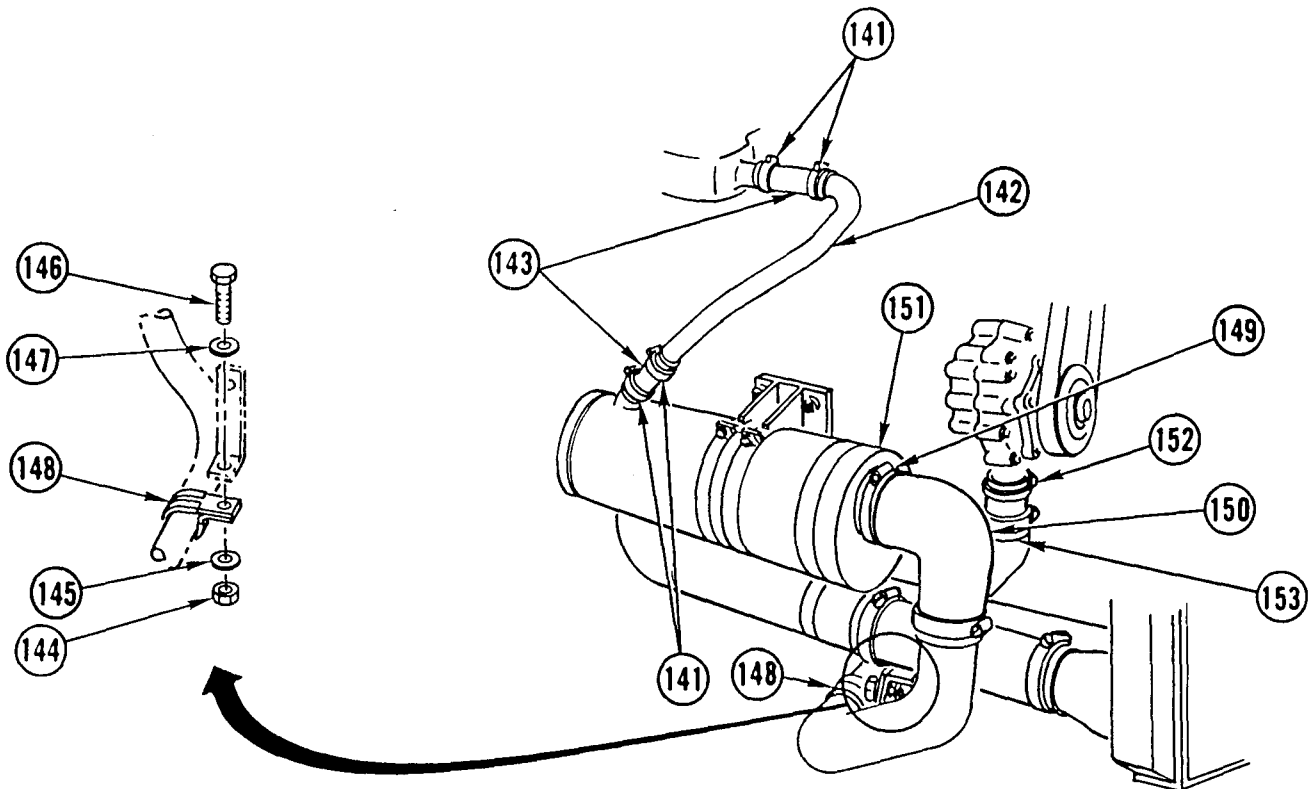

40. LOOSEN FOUR CLAMPS (141) AND REMOVE PIPE (142) AND TWO HOSES (143).
41. REMOVE NUT (144), WASHER (145), CAPSCREW (146), AND WASHER (147) FROM CLAMP (148).
42. LOOSEN CLAMP (149) AND DISCONNECT HOSE (150) FROM TRANSMISSION OIL COOLER (151).
43. LOOSEN CLAMP (152) AND REMOVE HOSE AND PIPE ASSEMBLY (153).

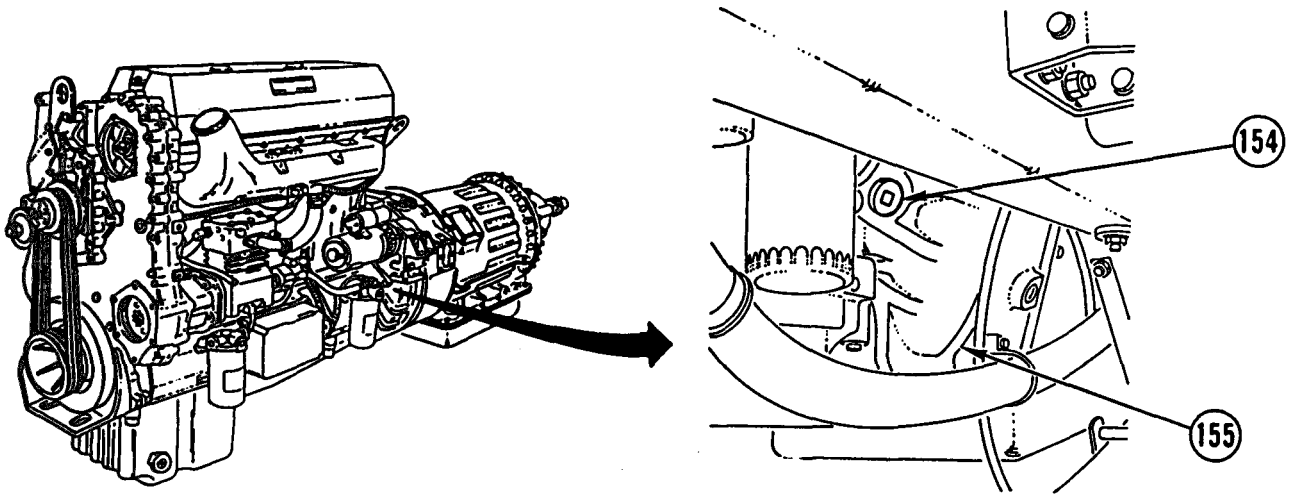

44. REMOVE PLUG (154) FROM ENGINE FLYWHEEL HOUSING (155).

ENGINE REPLACEMENT (CONT)

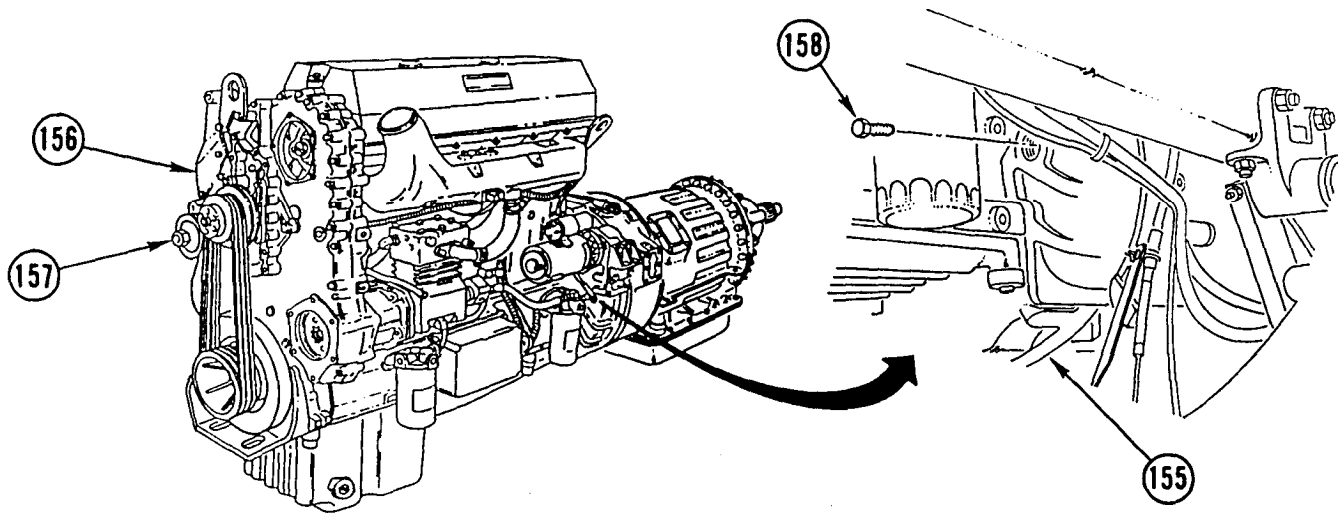

WARNING

Do not place finger in hole of engine flywheel housing while engine is being barred over. To do so could result in serious injury to personnel.

CAUTION

- Step 45 must be followed for barring engine over. Any other method could cause damage to equipment.
- If bolts are dropped in engine flywheel housing, retrieve immediately. Failure to do so could result in damage to equipment.

45. HAVE ASSISTANT BAR ENGINE (156) OVER USING ACCESSORY DRIVE (157). LOCATE AND REMOVE BOLT (158) THRU HOLE IN ENGINE FLYWHEEL HOUSING (155). REPEAT UNTIL 12 BOLTS (158) HAVE BEEN REMOVED.

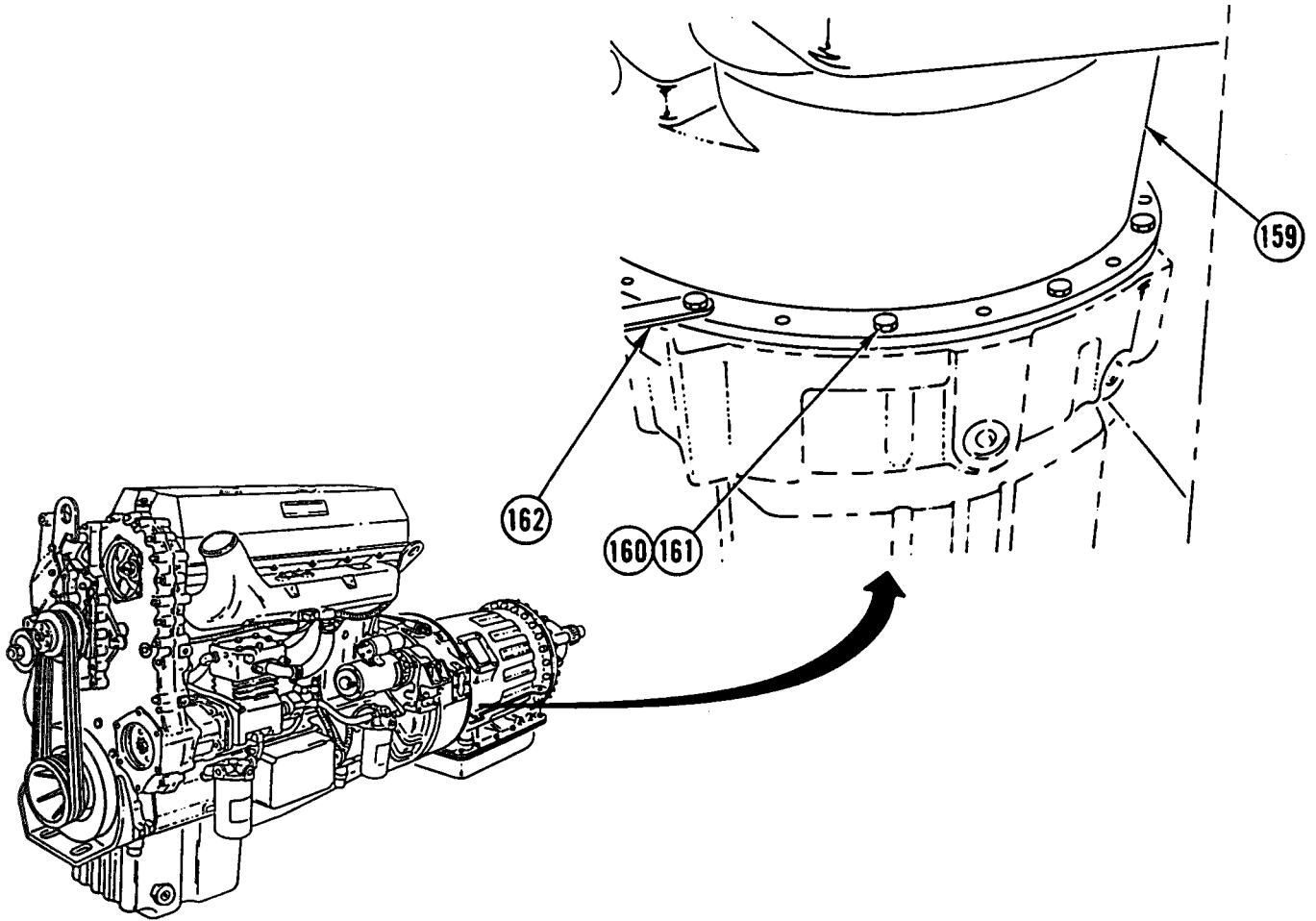

WARNING

Transmission weighs 900 lb (409 kg). Support transmission with transmission jack during removal to prevent possible injury to personnel.

46. SUPPORT TRANSMISSION (159) USING TRANSMISSION JACK. REMOVE 12 SCREWS (160), 12 LOCK WASHERS (161), AND TWO BRACKETS (162). DISCARD LOCK WASHERS.

ENGINE REPLACEMENT (CONT)

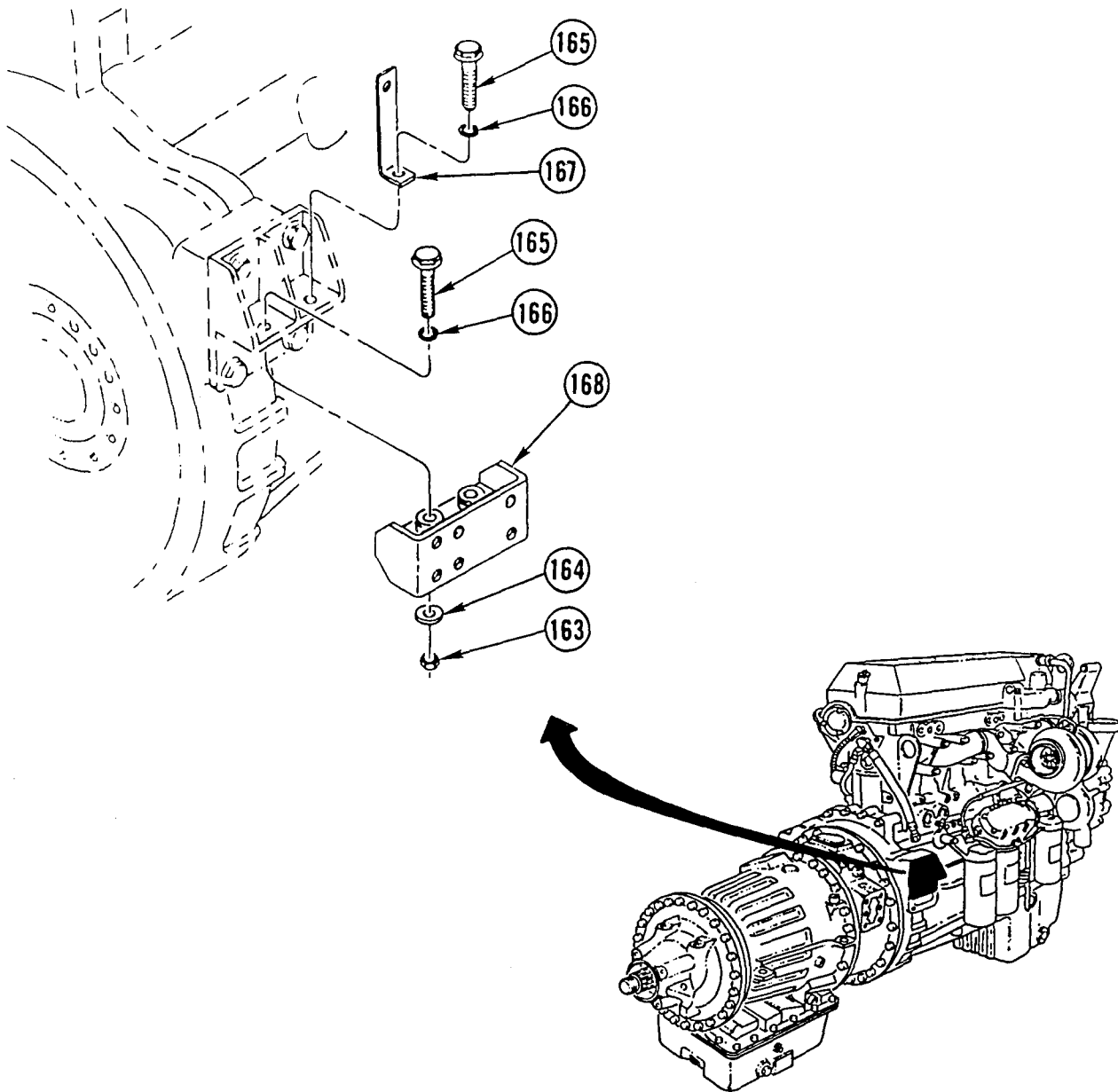

47. RIGHT SIDE ONLY: REMOVE TWO NUTS (163), TWO WASHERS (164), TWO SCREWS (165), TWO WASHERS (166), AND BRACKET (167) FROM RIGHT ENGINE MOUNT (168).

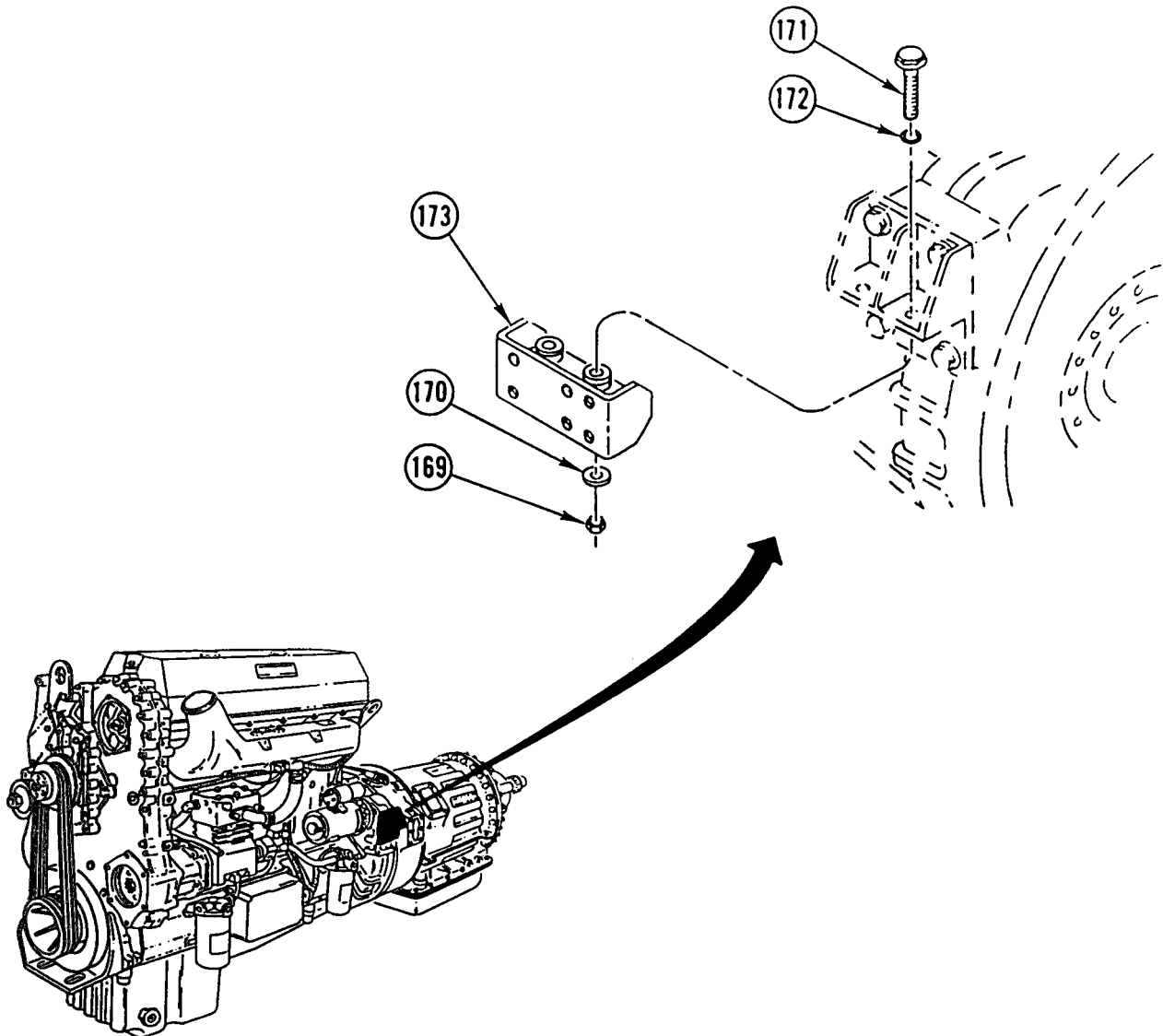

48. LEFT SIDE ONLY: REMOVE TWO NUTS (169), TWO WASHERS (170), TWO SCREWS (171), AND TWO WASHERS (172) FROM LEFT ENGINE MOUNT (173).

ENGINE REPLACEMENT (CONT)

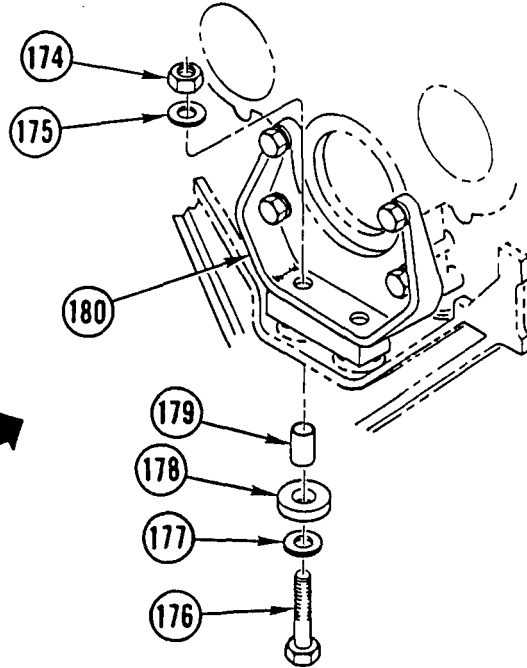
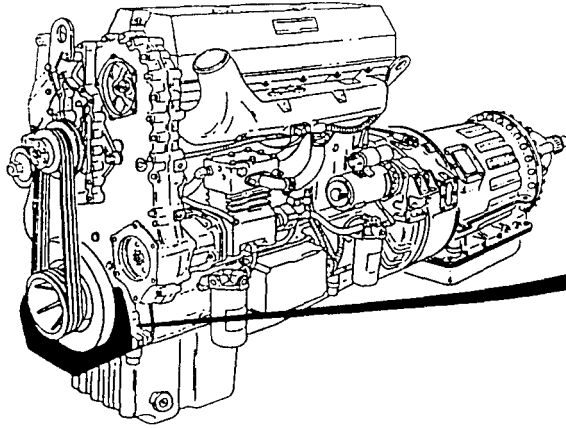

CAUTION

Keep engine clear of frame. Failure to do so could result in damage to equipment.

49. REMOVE TWO NUTS (174), TWO WASHERS (175), TWO SCREWS (176), TWO WASHERS (177), TWO ISOLATORS (178), AND TWO SLEEVES (179) FROM FRONT ENGINE MOUNT (180).

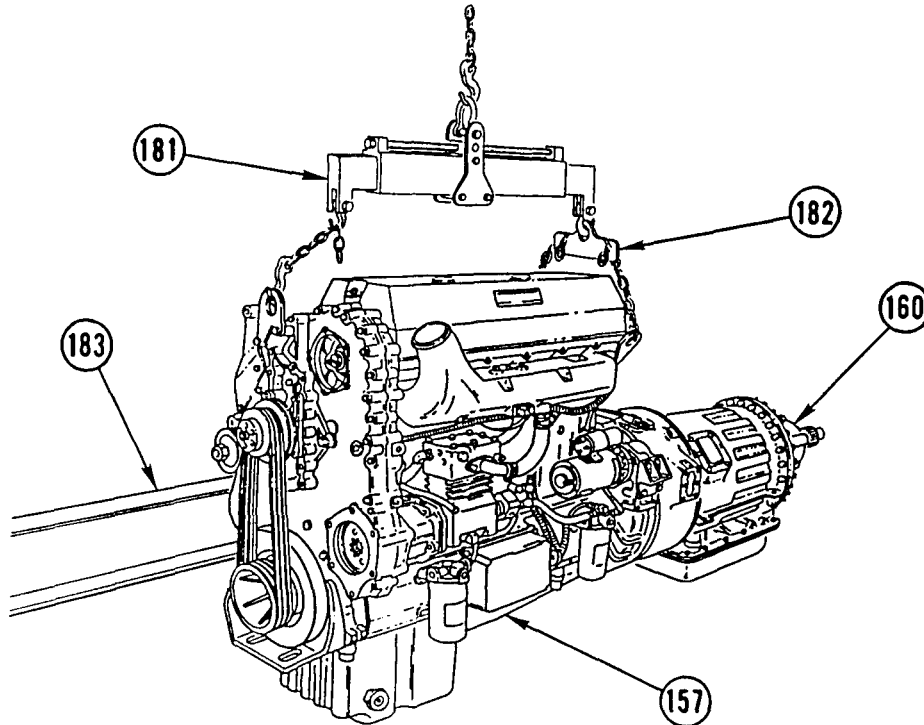

WARNING

Engine weighs 2,850 lb (1294 kg), Use hoist with lifting capacity of 5,000 lb (2270 kg) to lift and support engine. Failure to do so could result in injury to personnel.

CAUTION

- Make sure all harnesses, tubes, and hoses are clear of engine prior to removal. Failure to do so could result in damage to equipment.
- Keep engine clear of frame. Failure to do so could result in damage to equipment.

50. USING SUITABLE HOIST, LOAD ROTOR (181) AND SPREADER (182) AND LIFT ENGINE (157) SLIGHTLY.

CAUTION

To avoid binding during removal, check frequently to ensure proper alignment between engine and transmission. Failure to do so could result in damage to components.

51. RAISE AND ADJUST HEIGHT OF TRANSMISSION JACK TO MAINTAIN SUPPORT OF TRANSMISSION (160).
52. REPEAT STEPS 50 AND 51 UNTIL ENGINE (157) CAN BE SEPARATED FROM TRANSMISSION (160).
53. SEPARATE ENGINE (157) FROM TRANSMISSION (160), ADJUST LOAD ROTOR SO FRONT OF ENGINE (157) IS RAISED AS HIGH AS POSSIBLE TO CLEAR FRAME CROSSMEMBER, AND REMOVE ENGINE FROM VEHICLE (183).

ENGINE REPLACEMENT (CONT)

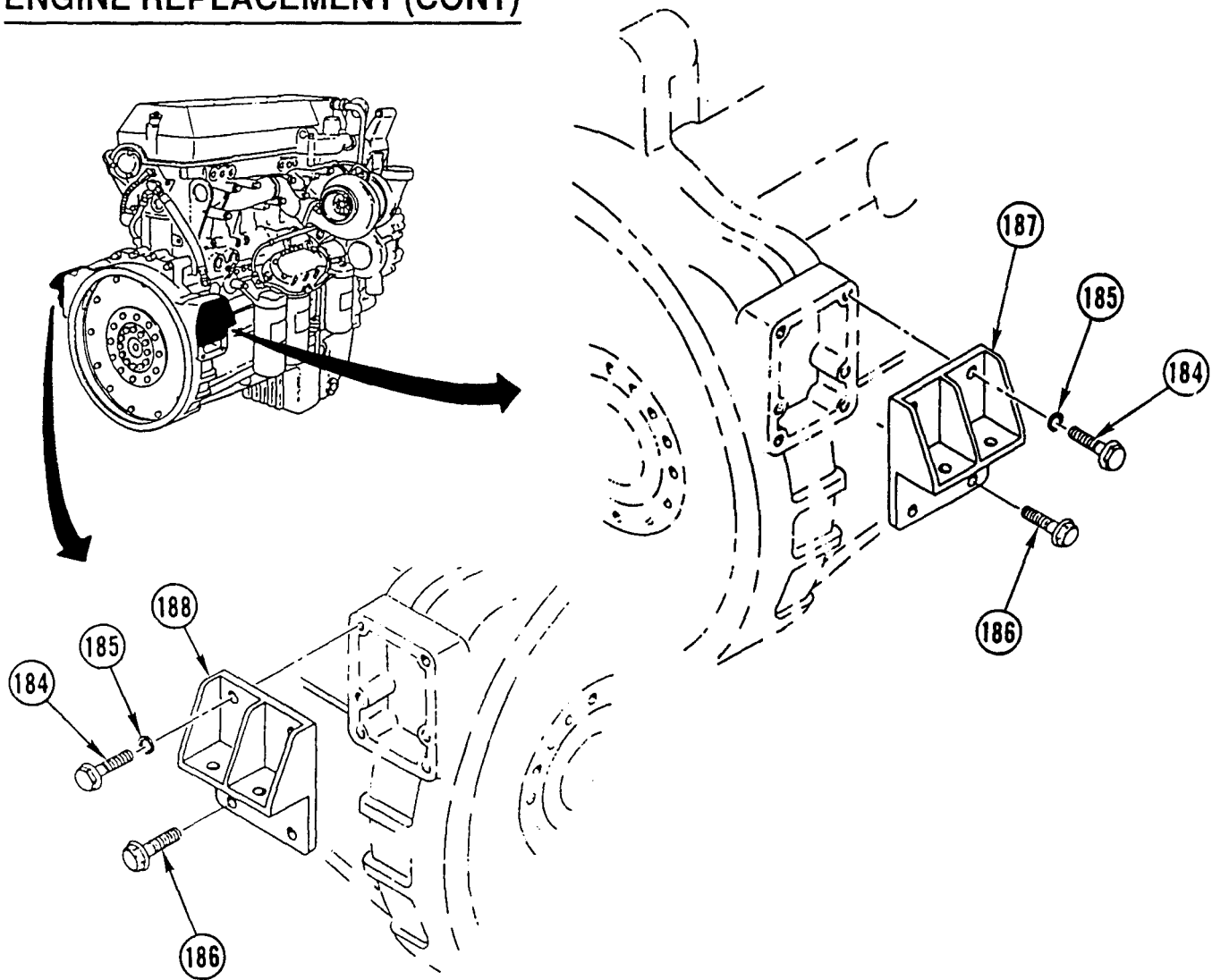

54. REMOVE TWO SCREWS (184), TWO WASHERS (185), TWO SCREWS (186), AND RIGHT ENGINE LEG (187).

55. REPEAT STEP 54 FOR LEFT ENGINE LEG (188).

56. LOWER ENGINE ONTO SUITABLE JACK STANDS.

Use general cleaning methods to clean all parts (page 2-30).

INSPECTION

1. INSPECT ENGINE MOUNTS FOR WEAR OR DAMAGE. REPLACE IF NECESSARY.
2. INSPECT ALL PARTS FOR WEAR OR DAMAGE.

INSTALLATION

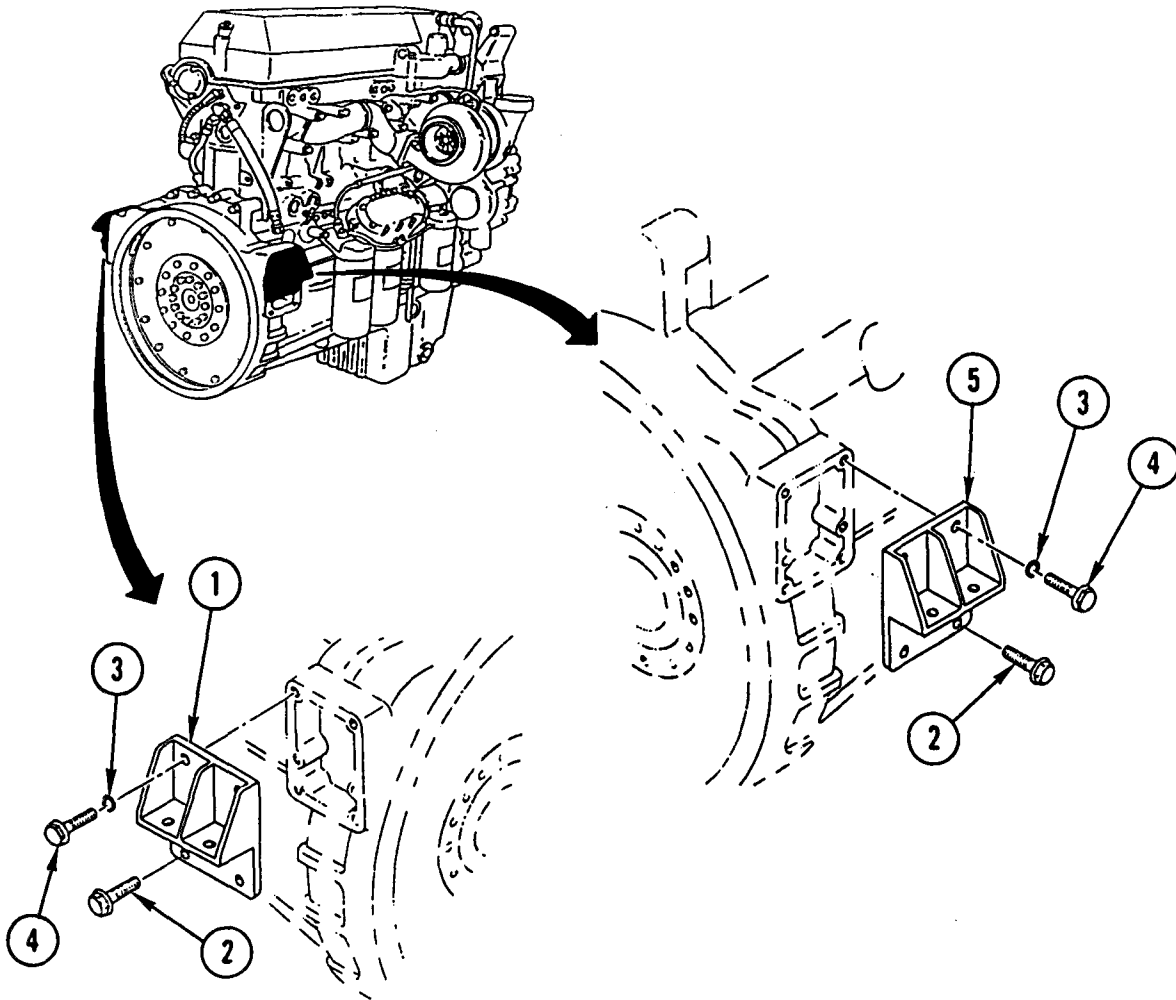

1. INSTALL LEFT ENGINE LEG (1), TWO SCREWS (2), TWO WASHERS (3), AND TWO SCREWS (4).
2. REPEAT STEP 1 FOR INSTALLATION OF RIGHT ENGINE LEG (5).

ENGINE REPLACEMENT (CONT)

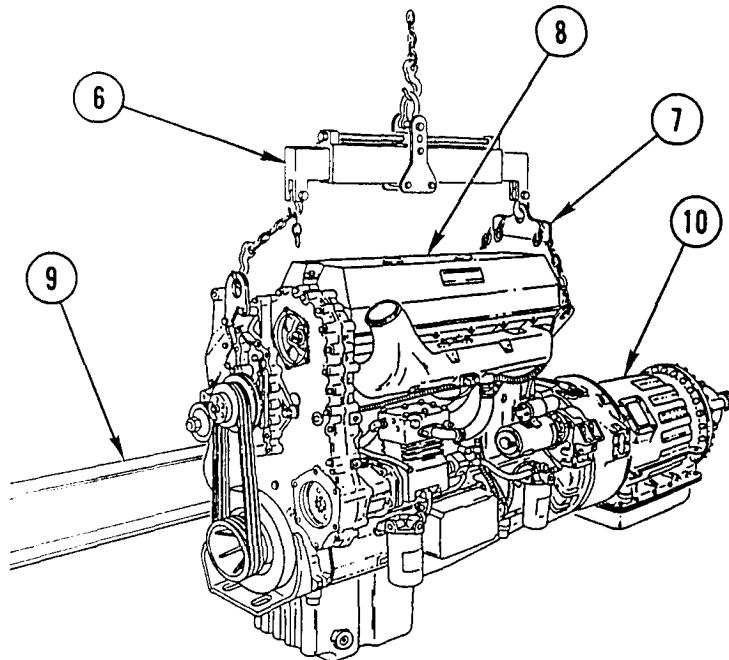

WARNING

- Engine weighs 2,850 lb (1294 kg). Use hoist with lifting capacity of 5,000 lb (2270 kg) to lift and support engine. Failure to do so could result in injury to personnel.
- Do not place hands between engine and frame or engine and transmission. To do so could result in serious personal injury.

CAUTION

- Make sure all harnesses, tubes, and hoses are clear of engine prior to removal. Failure to do so could result in damage to equipment.
- Keep engine clear of frame. Failure to do so could result in damage to equipment.

3. USING SUITABLE HOIST, LOAD ROTOR (6), AND SPREADER (7), MANEUVER ENGINE (8) INTO VEHICLE (9) AND MATE ENGINE (8) TO TRANSMISSION (10).
4. ALTERNATELY LOWER TRANSMISSION JACK AND ENGINE HOIST IN SMALL INCREMENTS UNTIL ENGINE (8) IS IN PLACE.

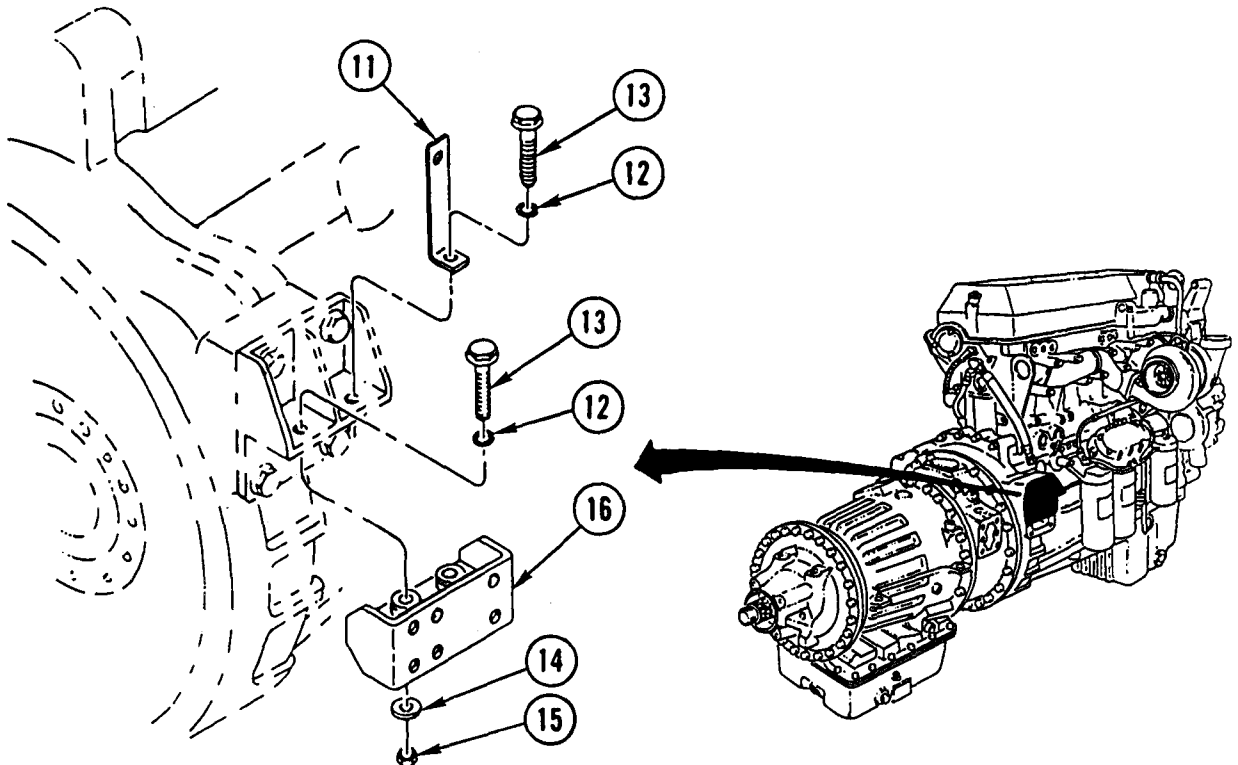

5. RIGHT SIDE ONLY: INSTALL BRACKET (11), TWO WASHERS (12), TWO SCREWS (13), TWO WASHERS (14), AND TWO NUTS (15) IN RIGHT ENGINE MOUNT (16). DO NOT TIGHTEN NUTS.

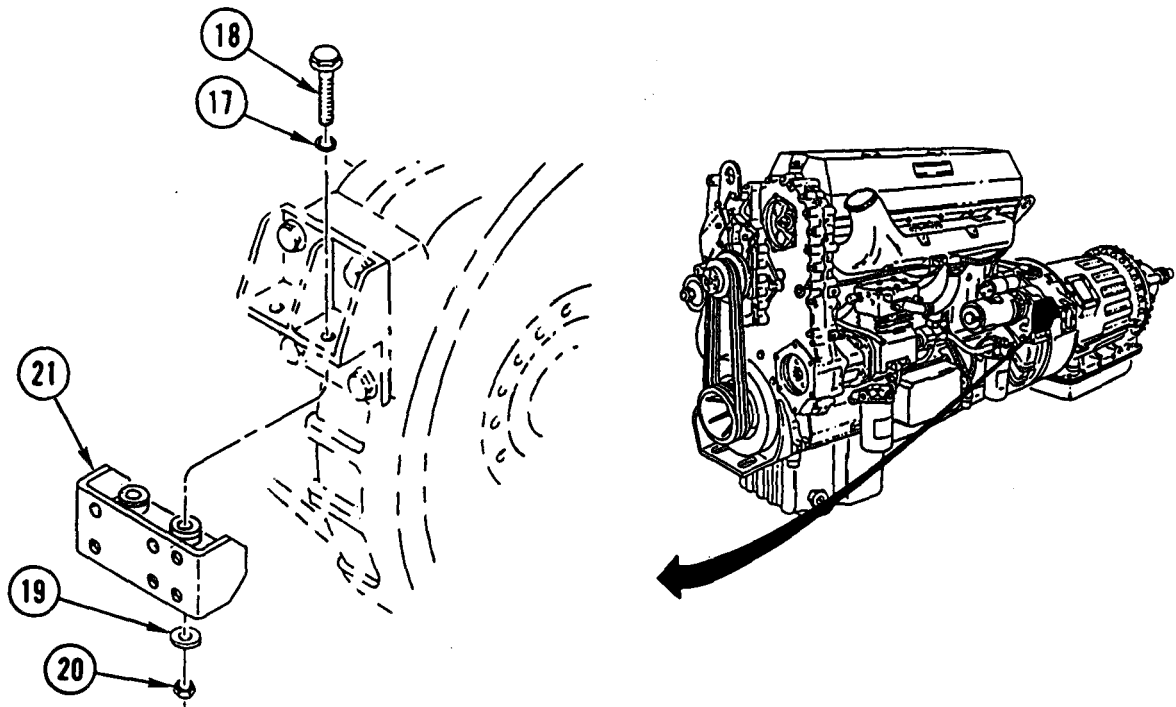

6. LEFT SIDE ONLY: INSTALL TWO WASHERS (17), TWO SCREWS (18), TWO WASHERS (19), AND TWO NUTS (20) IN LEFT ENGINE MOUNT (21). DO NOT TIGHTEN NUTS.

ENGINE REPLACEMENT (CONT)

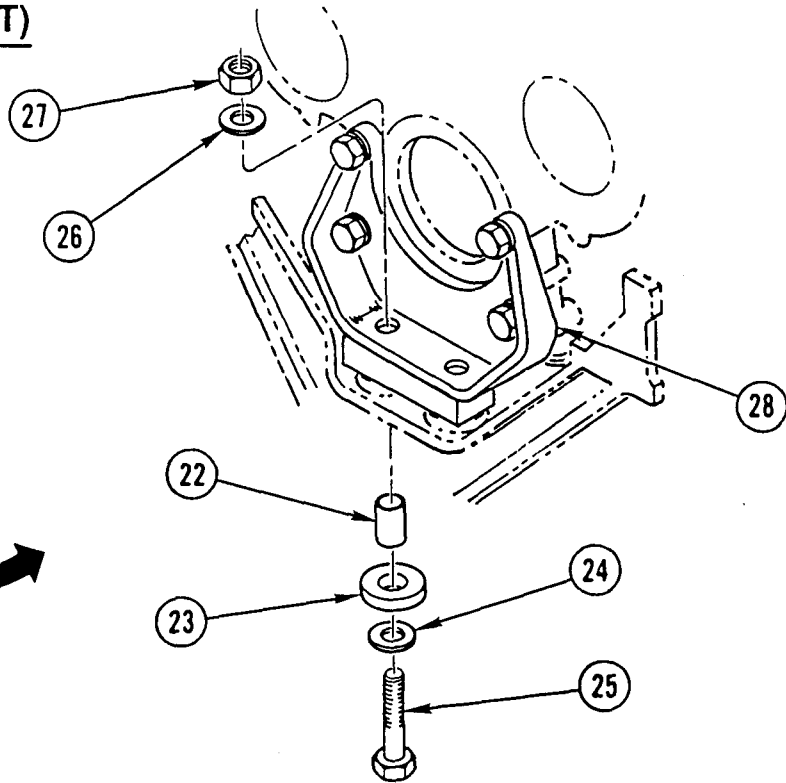
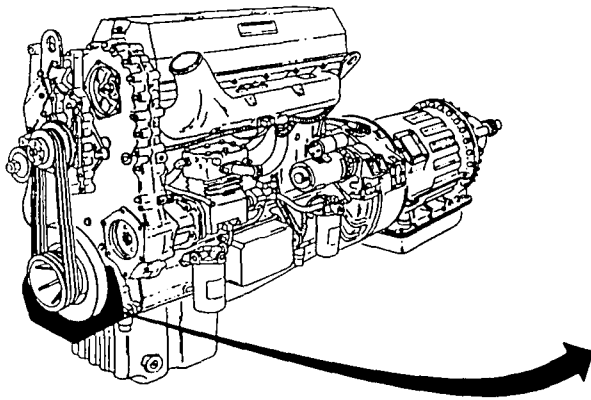

7. INSTALL TWO SLEEVES (22), TWO ISOLATORS (23), TWO WASHERS (24), TWO SCREWS (25), TWO WASHERS (26), AND TWO NUTS (27) IN FRONT ENGINE MOUNT.

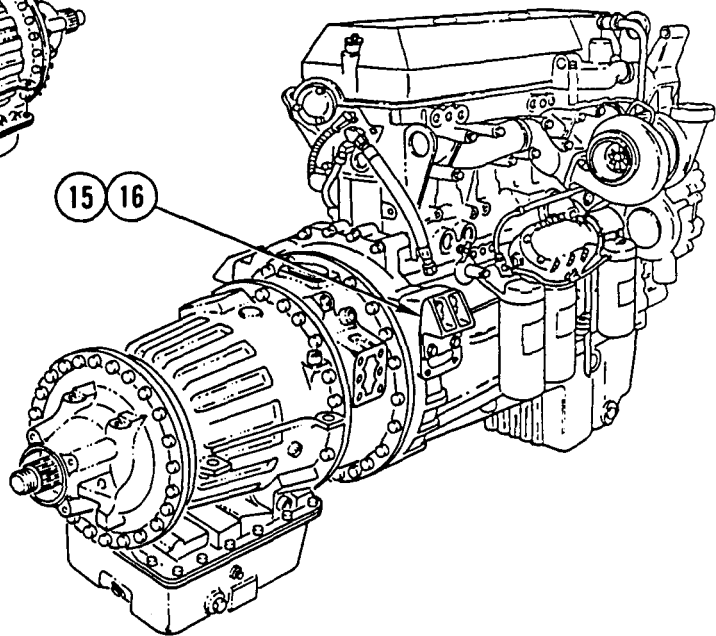
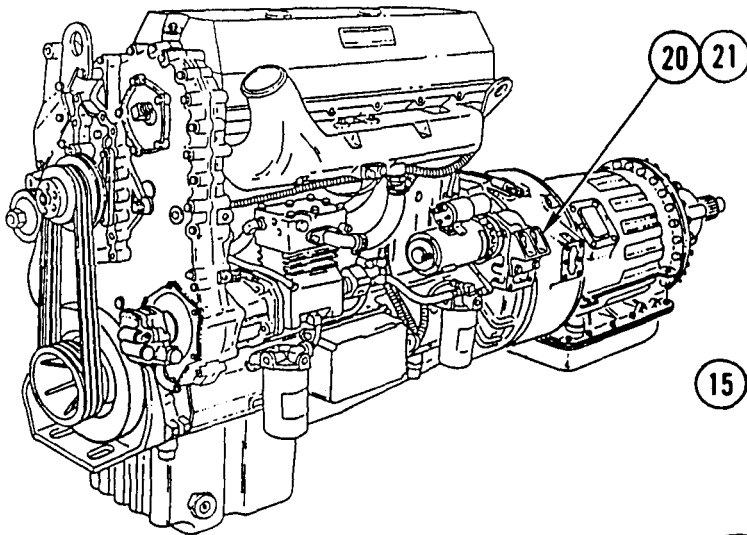

8. TIGHTEN FOUR NUTS (15 AND 20) ON TWO REAR ENGINE MOUNTS (16 AND 21).

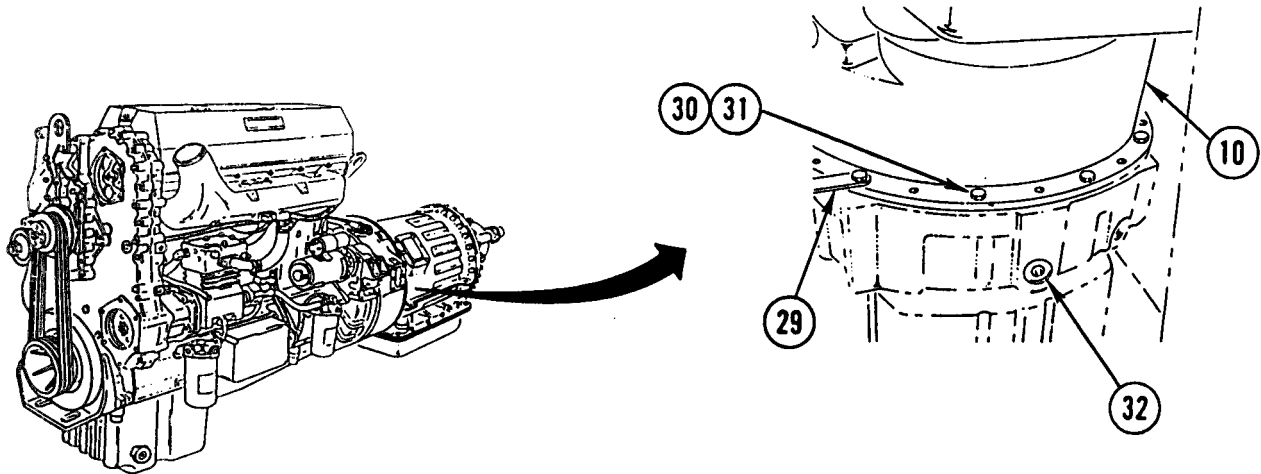

CAUTION

Transmission must be seated squarely against engine flywheel housing to prevent damage to equipment.

9. INSTALL TWO BRACKETS (29), 12 NEW LOCK WASHERS (30), AND 12 SCREWS (31) IN TRANSMISSION (10), TIGHTEN SCREWS HAND-TIGHT.
10. TIGHTEN FOUR SCREWS (31) 90 DEGREES APART TO 40 LB-FT (55 N.m).
11. TIGHTEN REMAINING SCREWS (31) TO 40 LB-FT (55 N.m).
12. REMOVE PLUG (32) AND ROTATE TORQUE CONVERTOR TO ALINE HOLES IN FLEX PLATE WITH HOLES IN TORQUE CONVERTOR.

ENGINE REPLACEMENT (CONT)

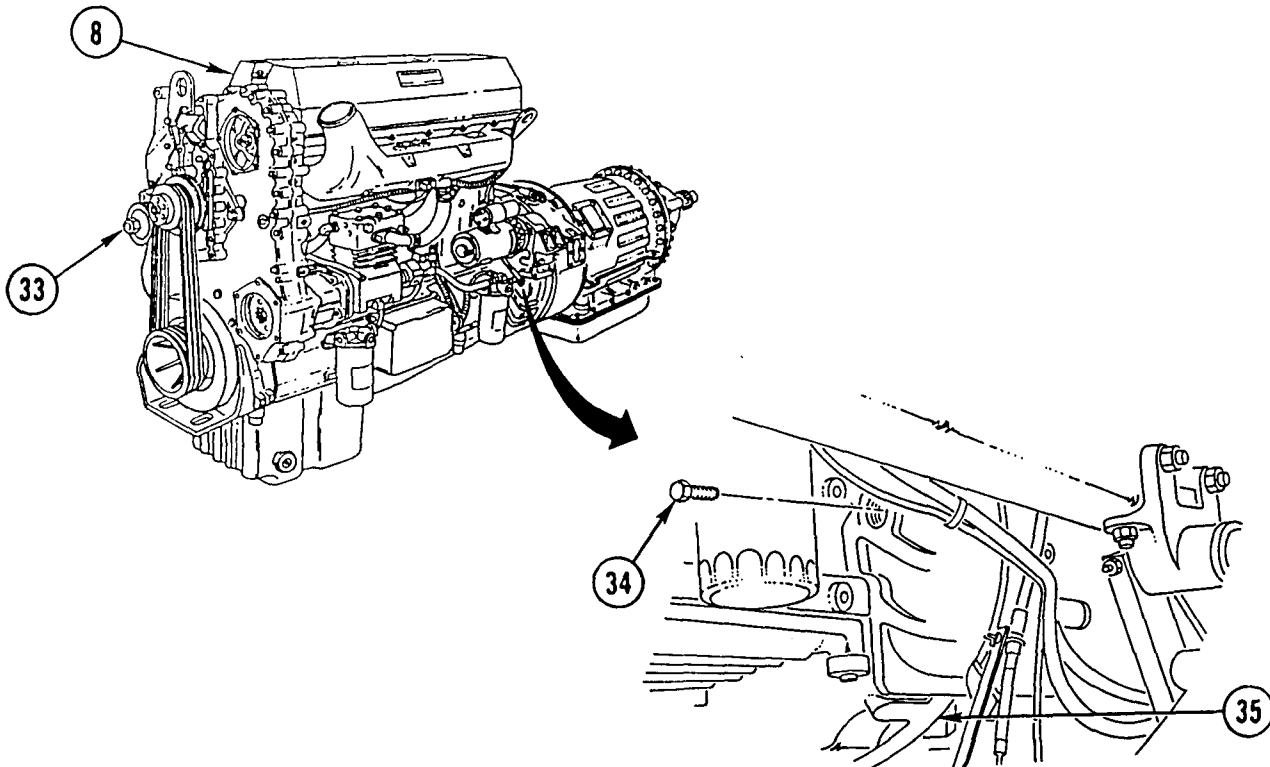

WARNING

Do not place finger in hole of engine flywheel housing while engine is being barred over. To do so could result in serious injury to personnel.

CAUTION

- Step 13 must be followed for barring over engine. Any other method could cause damage to equipment.
- If bolts are dropped in engine flywheel housing, retrieve immediately. Failure to do so could result in damage to equipment.

13. HAVE ASSISTANT BAR ENGINE (8) OVER USING ACCESSORY DRIVE (33). LOCATE AND ALINE HOLES AND INSTALL BOLT (34) THRU HOLE IN ENGINE FLYWHEEL HOUSING (35). REPEAT UNTIL 12 BOLTS (34) HAVE BEEN INSTALLED HAND-TIGHT.

14. TIGHTEN 12 BOLTS (34) TO 96-115 LB-FT (131-156 N.m).

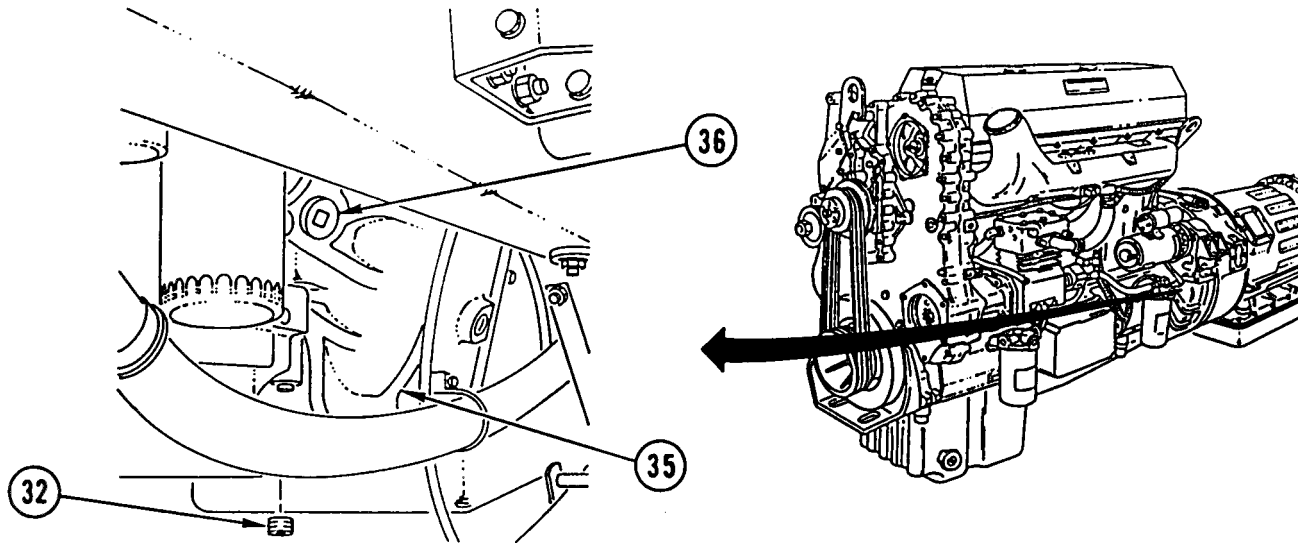

15. INSTALL TWO PLUGS (32 AND 36) IN ENGINE FLYWHEEL HOUSING (35).

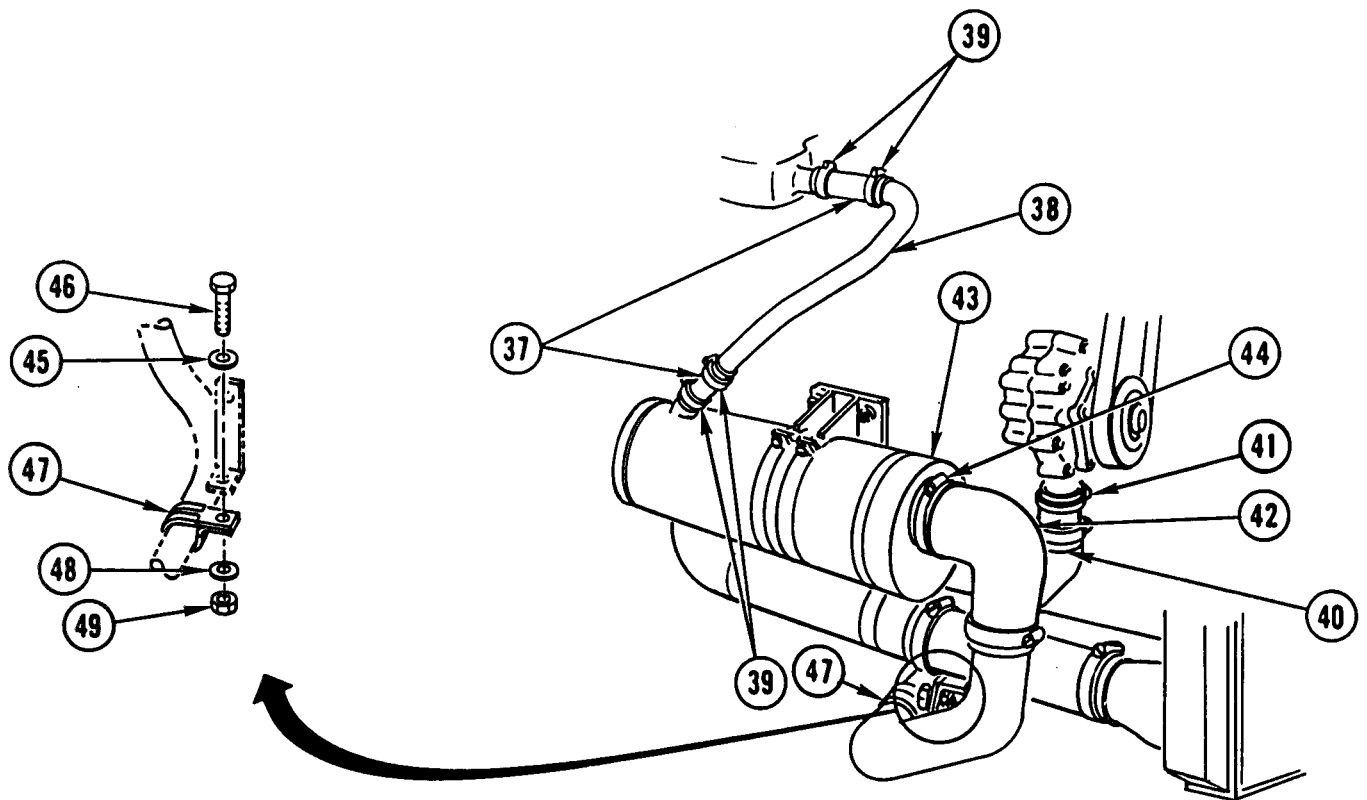

16. INSTALL TWO HOSES (37) AND PIPE (38) AND TIGHTEN FOUR CLAMPS (39).
17. INSTALL HOSE AND PIPE ASSEMBLY (40) AND TIGHTEN CLAMP (41).
18. CONNECT HOSE (42) TO TRANSMISSION OIL COOLER (43) AND TIGHTEN CLAMP (44).
19. INSTALL WASHER (45), CAPSCREW (46), CLAMP (47), WASHER (48), AND NUT (49).

ENGINE REPLACEMENT (CONT)

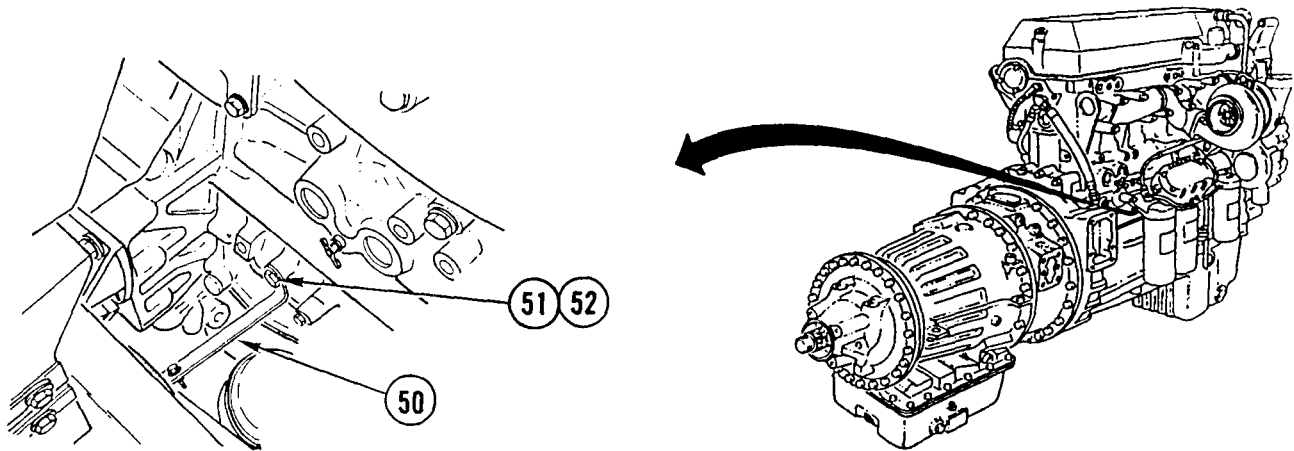

20. ROTATE BRACKET (50) INTO POSITION AND INSTALL WASHER (51) AND SCREW (52).

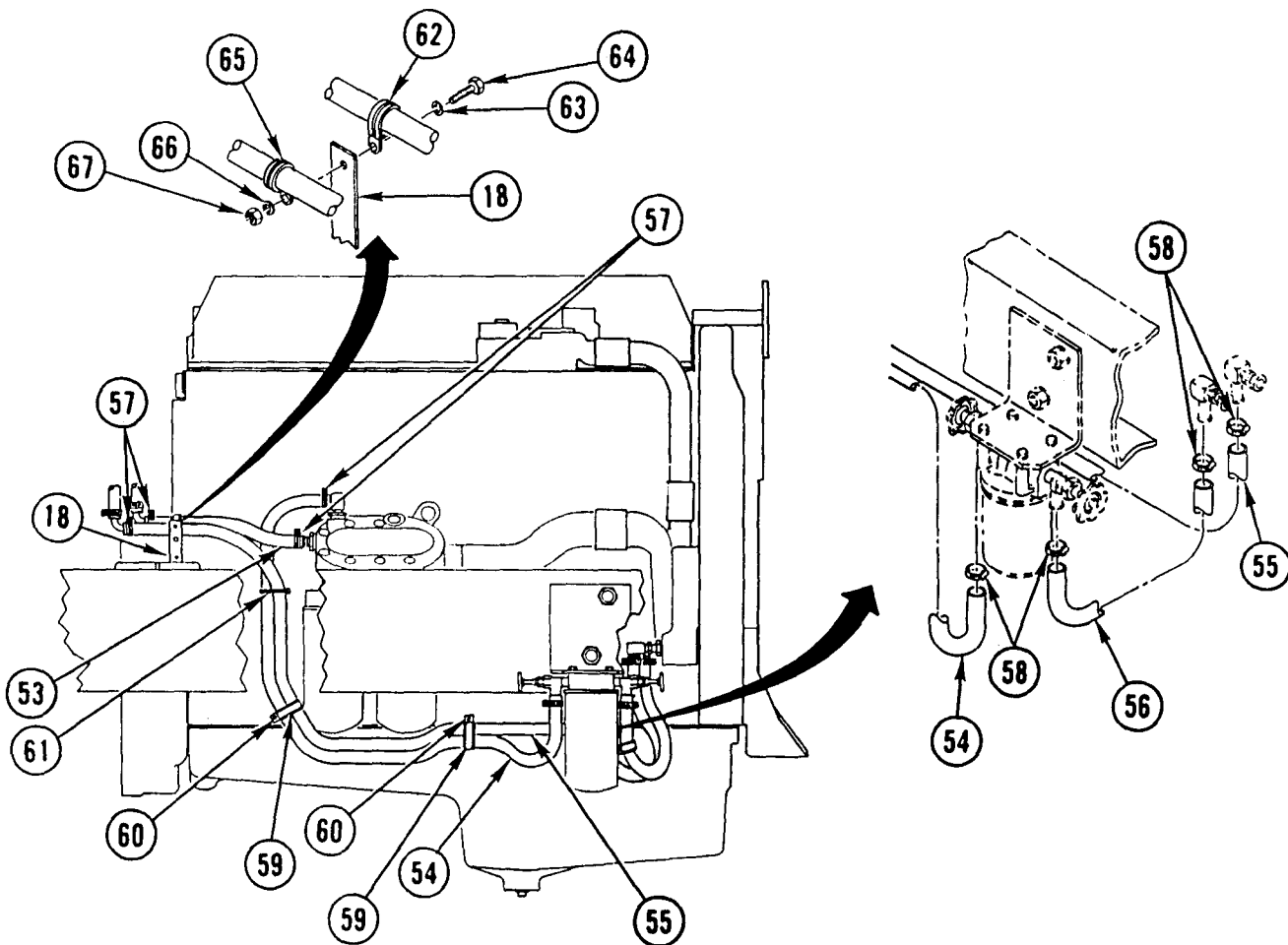

21. INSTALL FOUR HOSES (53, 54, 55, AND 56) AND FOUR CLAMPS (57).

22. CONNECT THREE HOSES (54, 55, AND 56) AND INSTALL FOUR CLAMPS (58).

23. INSTALL TWO CLAMPS (59), TWO BOLTS (60), AND TIE STRAP (61).

24. INSTALL CLAMP (62), WASHER (63), SCREW (64), CLAMP (65), WASHER (66), AND NEW LOCK NUT (67) ON BRACKET (18).

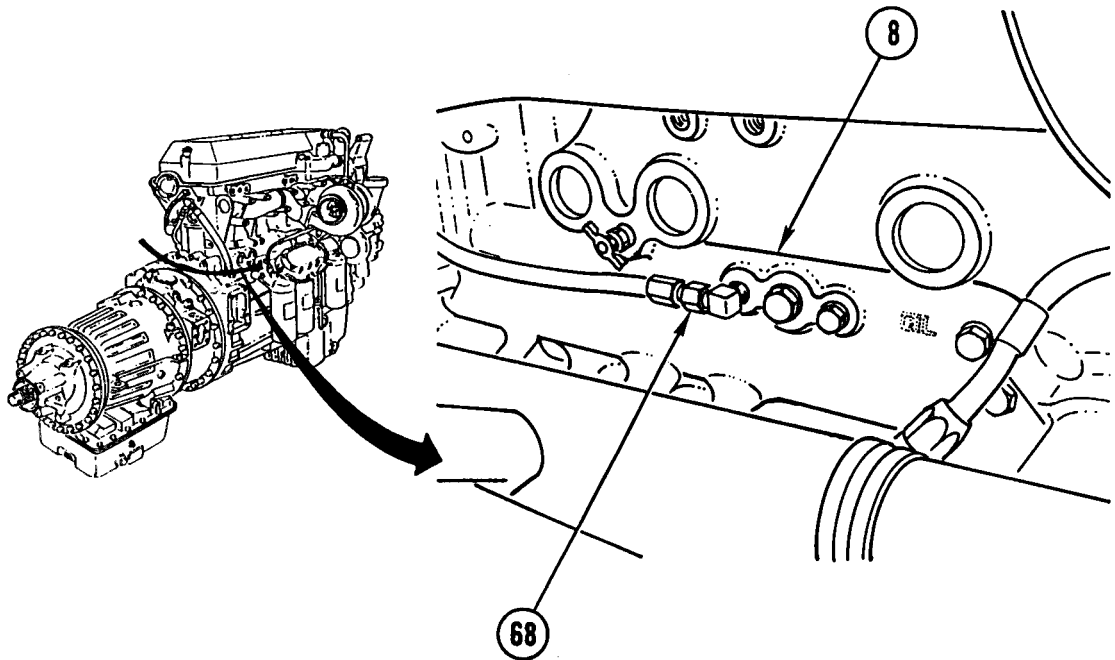

25. UNPLUG AND CONNECT OIL PRESSURE HOSE (68) TO ENGINE (8).

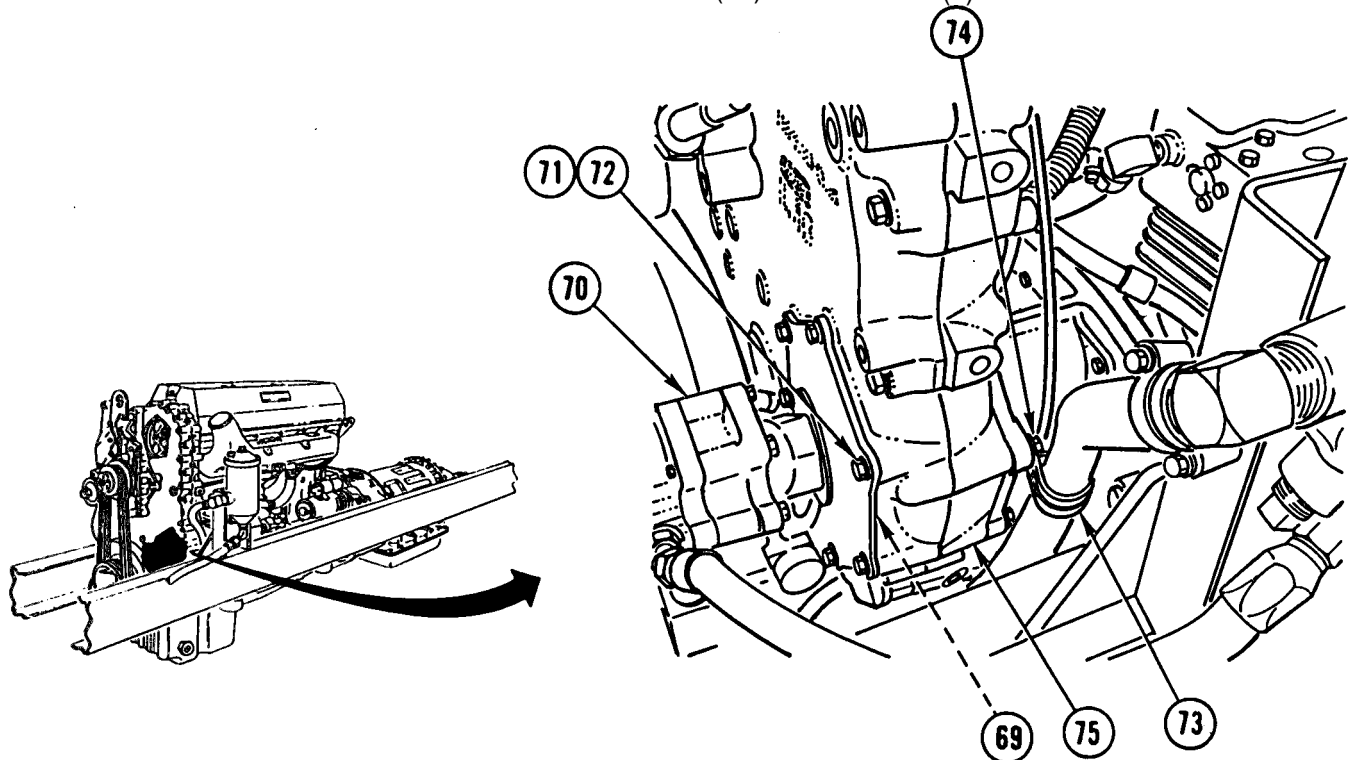

26. INSTALL DRIVE COUPLER (69), POWER STEERING PUMP (70), SIX NEW LOCK WASHERS (71), AND SIX SCREWS (72).

27. INSTALL CLAMP (73) AND SCREW (74) IN GEAR CASE (75).

ENGINE REPLACEMENT (CONT)

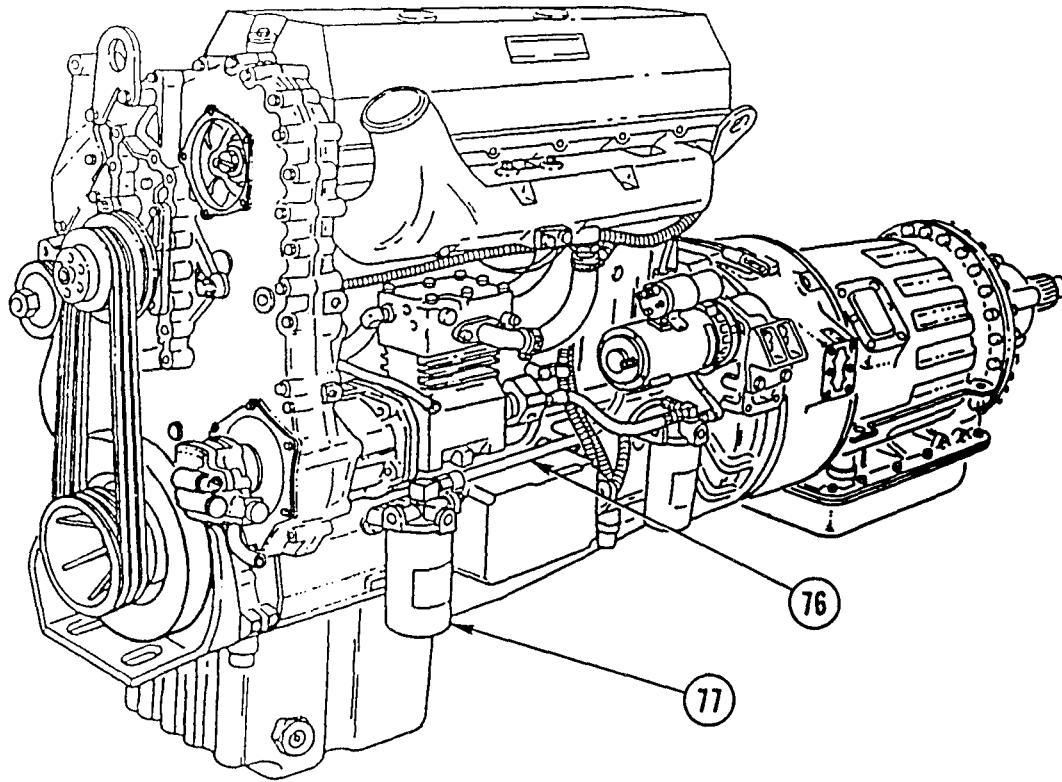

28. UNPLUG AND CONNECT FUEL HOSE (76) TO PRIMARY FUEL FILTER (77).

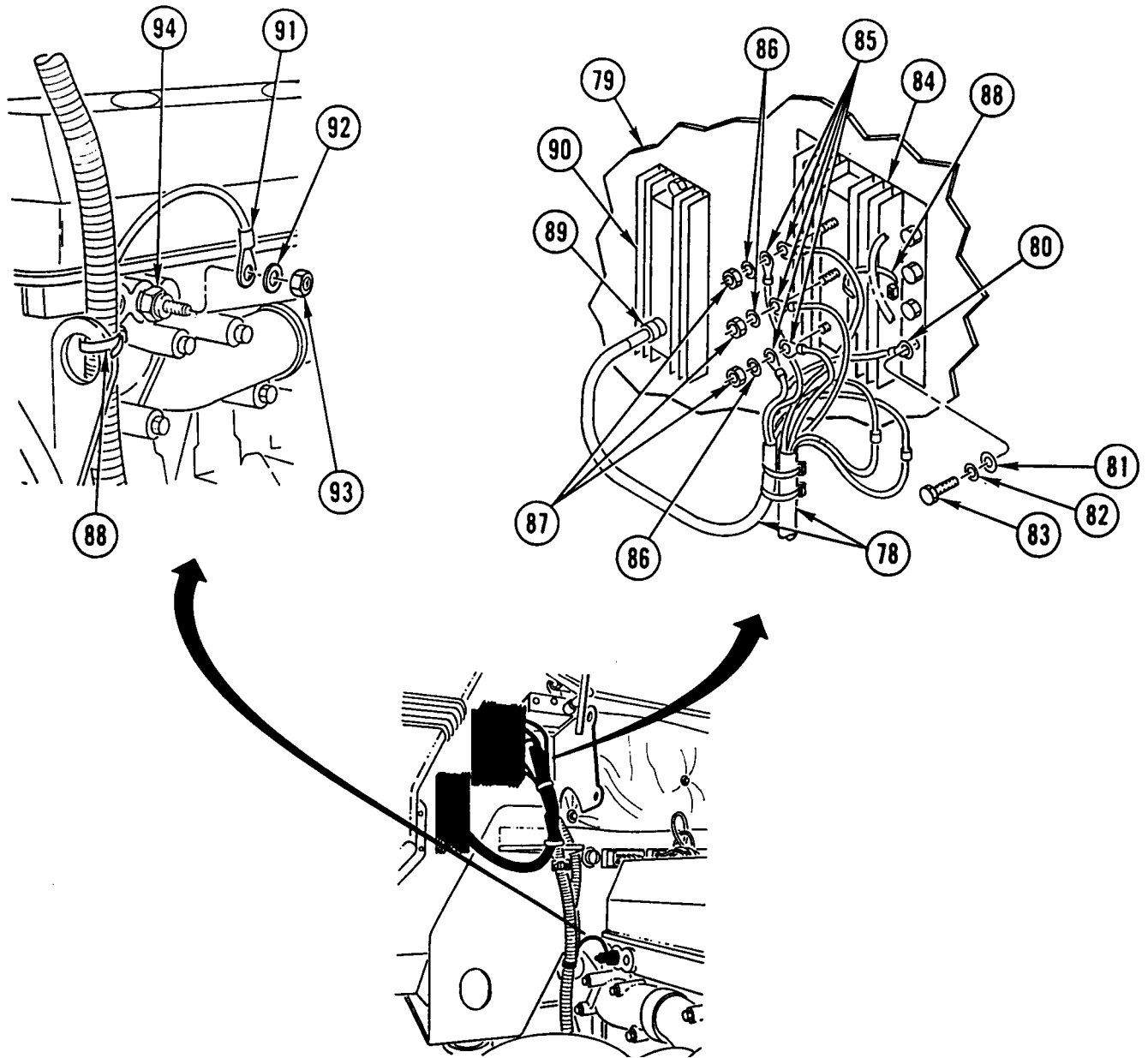

29. PULL HARNESS (78) OUT FROM UNDER CAB (79) AND INSTALL GROUND WIRE (80), WASHER (81), NEW LOCK WASHER (82), AND SCREW (83) IN DUAL VOLTAGE CONTROL (84).
30. INSTALL FIVE WIRES (85), THREE WASHERS (86), THREE NUTS (87), AND TWO WIRE TIES (88) ON DUAL VOLTAGE CONTROL (84).
31. CONNECT PLUG (89) TO VOLTAGE REGULATOR (90).
32. INSTALL WIRE (91), NEW LOCK WASHER (92), AND NUT (93) ON SENDING UNIT (94).

ENGINE REPLACEMENT (CONT)

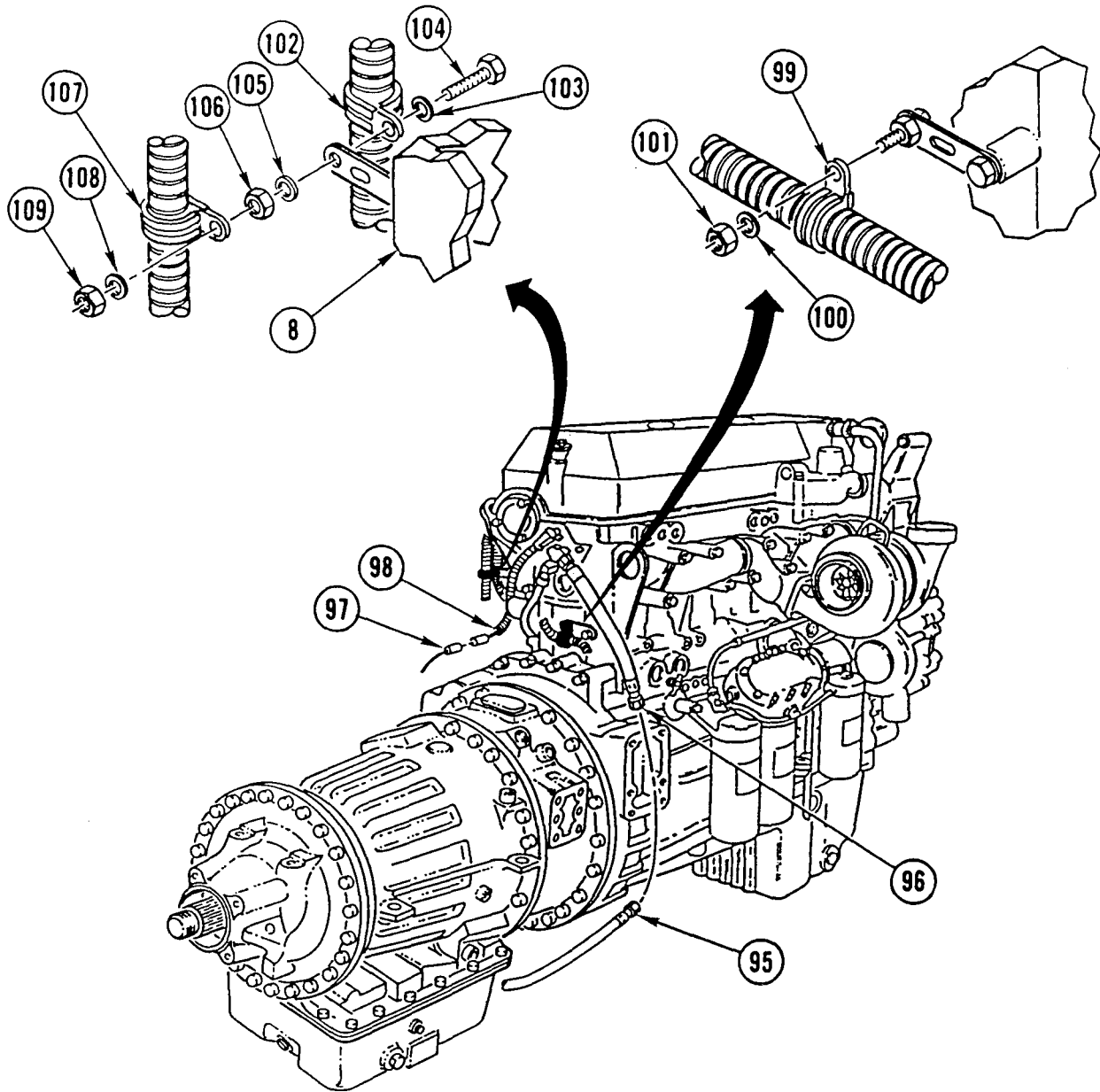

NOTE

Steps 33 thru 37 can be performed thru center floor panel of cab.

33. UNPLUG AND CONNECT FUEL RETURN HOSE (95) TO HOSE (96).
34. CONNECT CONNECTOR (97) TO ENGINE BRAKE HARNESS (98).
35. INSTALL CLAMP (99), WASHER (100), AND NEW LOCK NUT (101).
36. INSTALL CLAMP (102), WASHER (103), SCREW (104), WASHER (105), AND NEW LOCK NUT (106).
37. INSTALL CLAMP (107), WASHER (108), AND NEW LOCK NUT (109) ON REAR OF ENGINE (8).

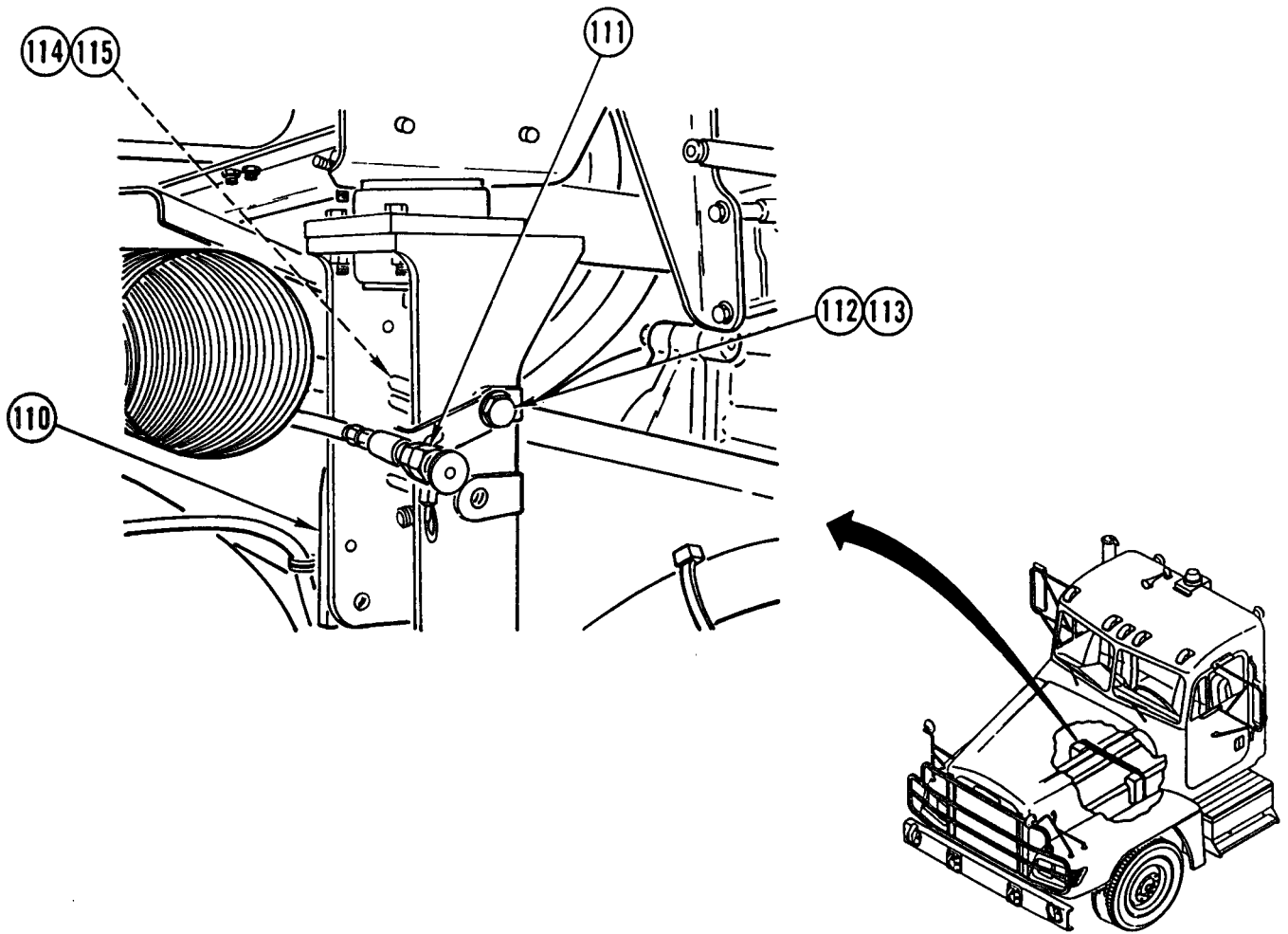

38. INSTALL CROSSMEMBER (110), TRANSMISSION OIL SAMPLE VALVE (111), WASHER (112), SCREW (113), WASHER (114), AND NUT (115).

ENGINE REPLACEMENT (CONT)

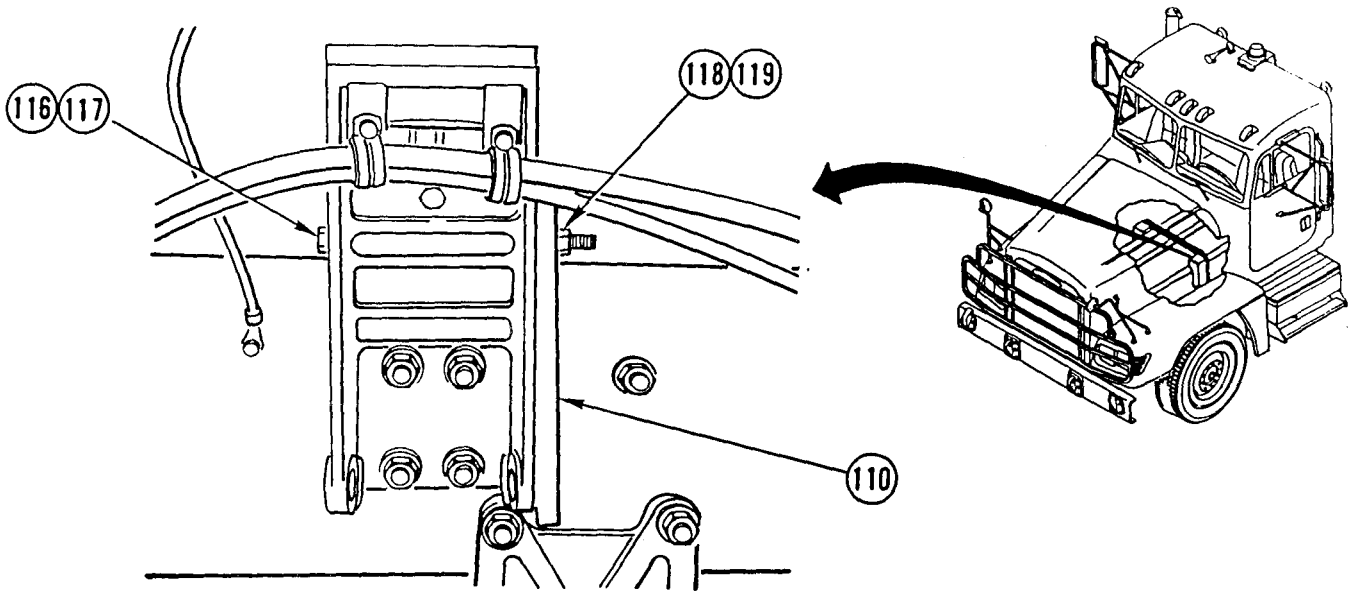

39. INSTALL WASHER (116), SCREW (117), WASHER (118), AND NUT (119) IN LEFT END OF CROSSMEMBER (110).

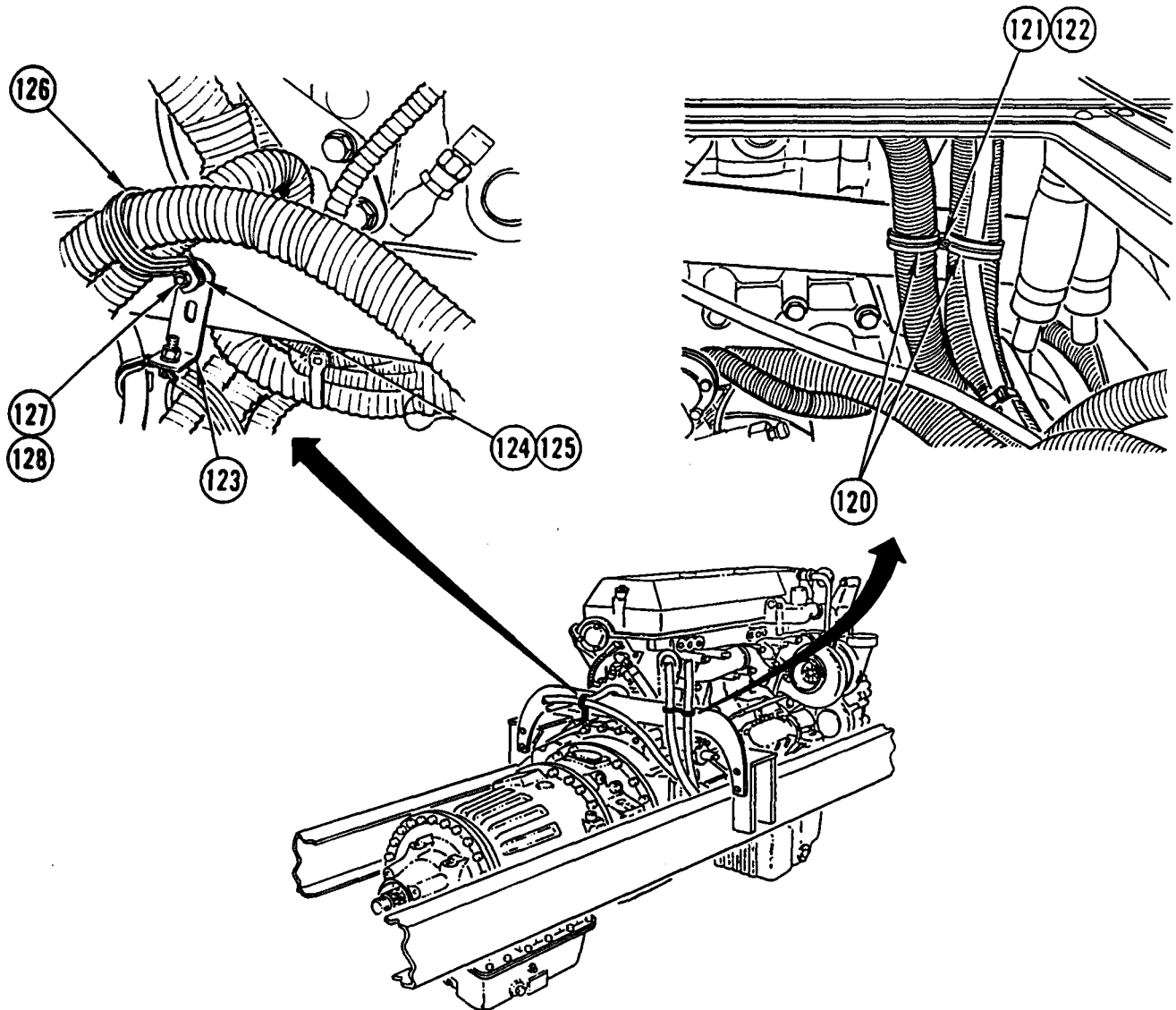

NOTE

Steps 40 thru 42 can be performed thru center floor panel of cab.

- 40. INSTALL TWO CLAMPS (120), WASHER (121), AND NEW LOCK NUT (122).
- 41. INSTALL BRACKET (123), WASHER (124), AND NEW LOCK NUT (125) ON CROSS MEMBER (110).
- 42. INSTALL CLAMP (126), WASHER (127), AND NEW LOCK NUT (128).

ENGINE REPLACEMENT (CONT)

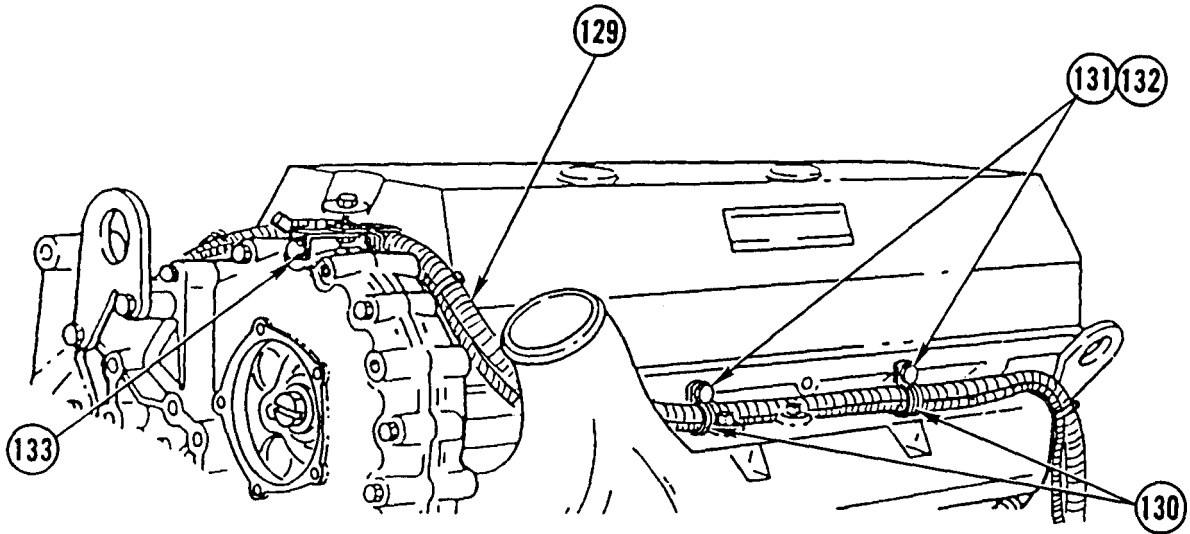

43. POSITION HARNESS (129) AND INSTALL TWO CLAMPS (130), TWO WASHERS (131), AND TWO SCREWS (132).

44. REMOVE SCREW (133). POSITION HARNESS (129) AND INSTALL SCREW (133).

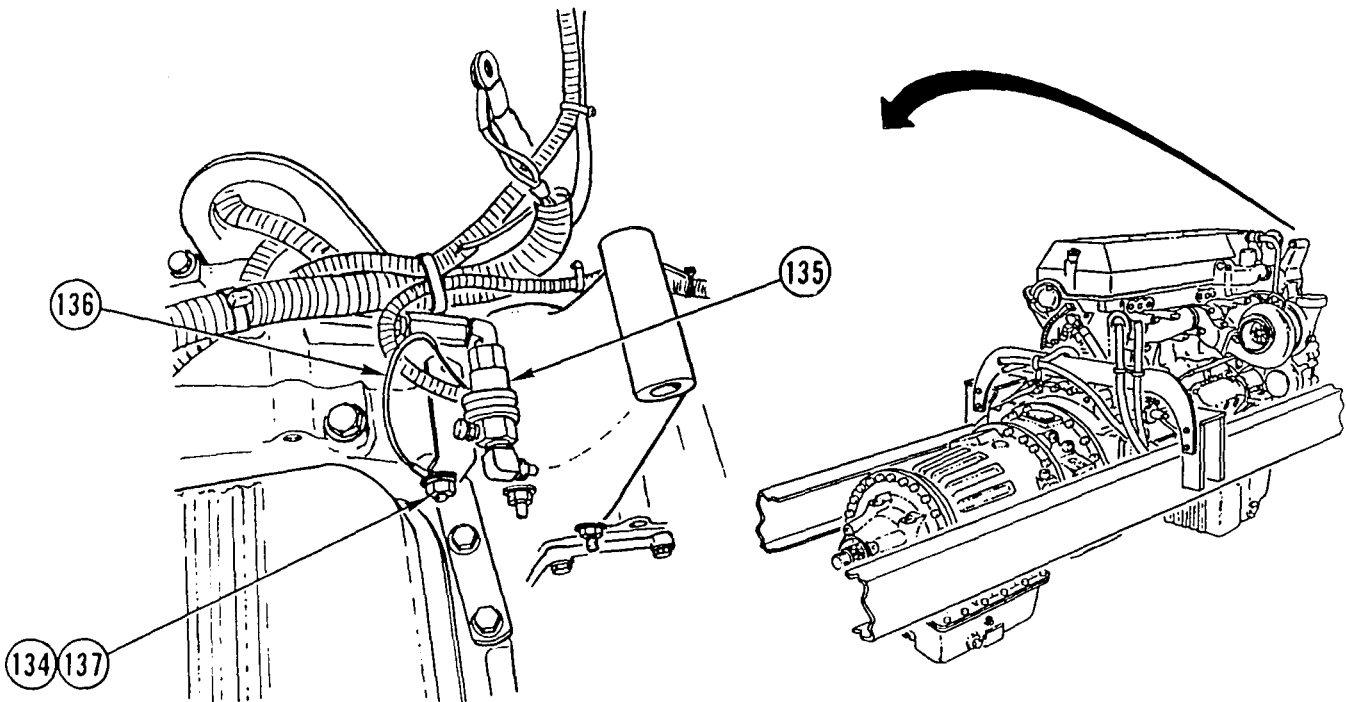

45. REMOVE NUT (134). INSTALL SOLENOID (135), WIRE (136), WASHER (137), AND NUT (134).

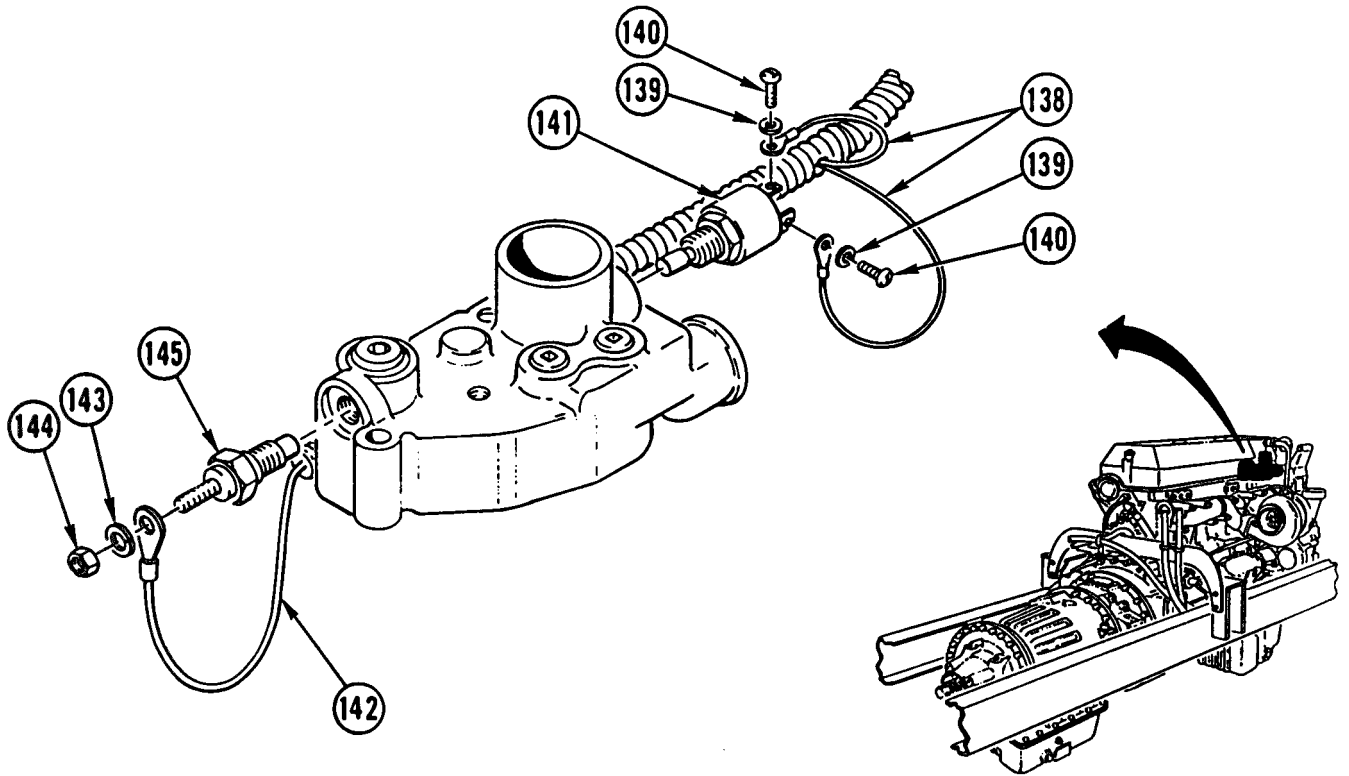

46. INSTALL TWO WIRES (138), TWO NEW LOCK WASHERS (139), AND TWO SCREWS (140) ON TEMPERATURE SENDING UNIT (141).

47. INSTALL WIRE (142), NEW LOCK WASHER (143), AND NUT (144) ON TEMPERATURE SENDING UNIT (145).

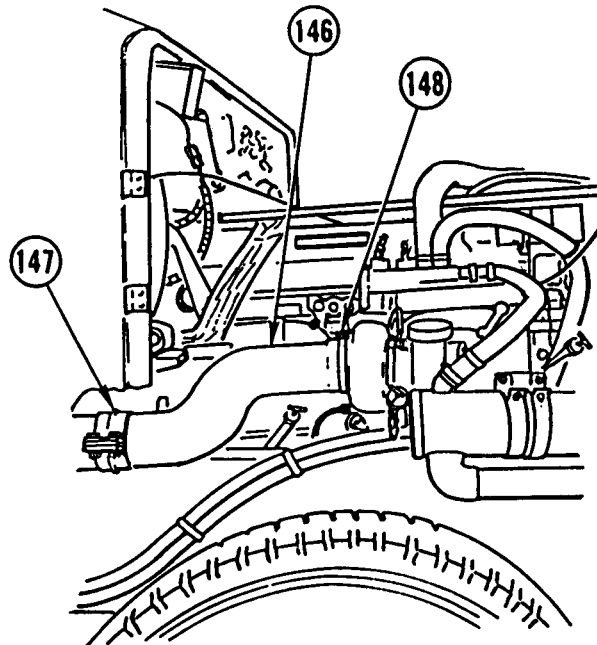

46. INSTALL EXHAUST PIPE (146), NEW SEAL CLAMP (147), AND CLAMP (148).

ENGINE REPLACEMENT (CONT)

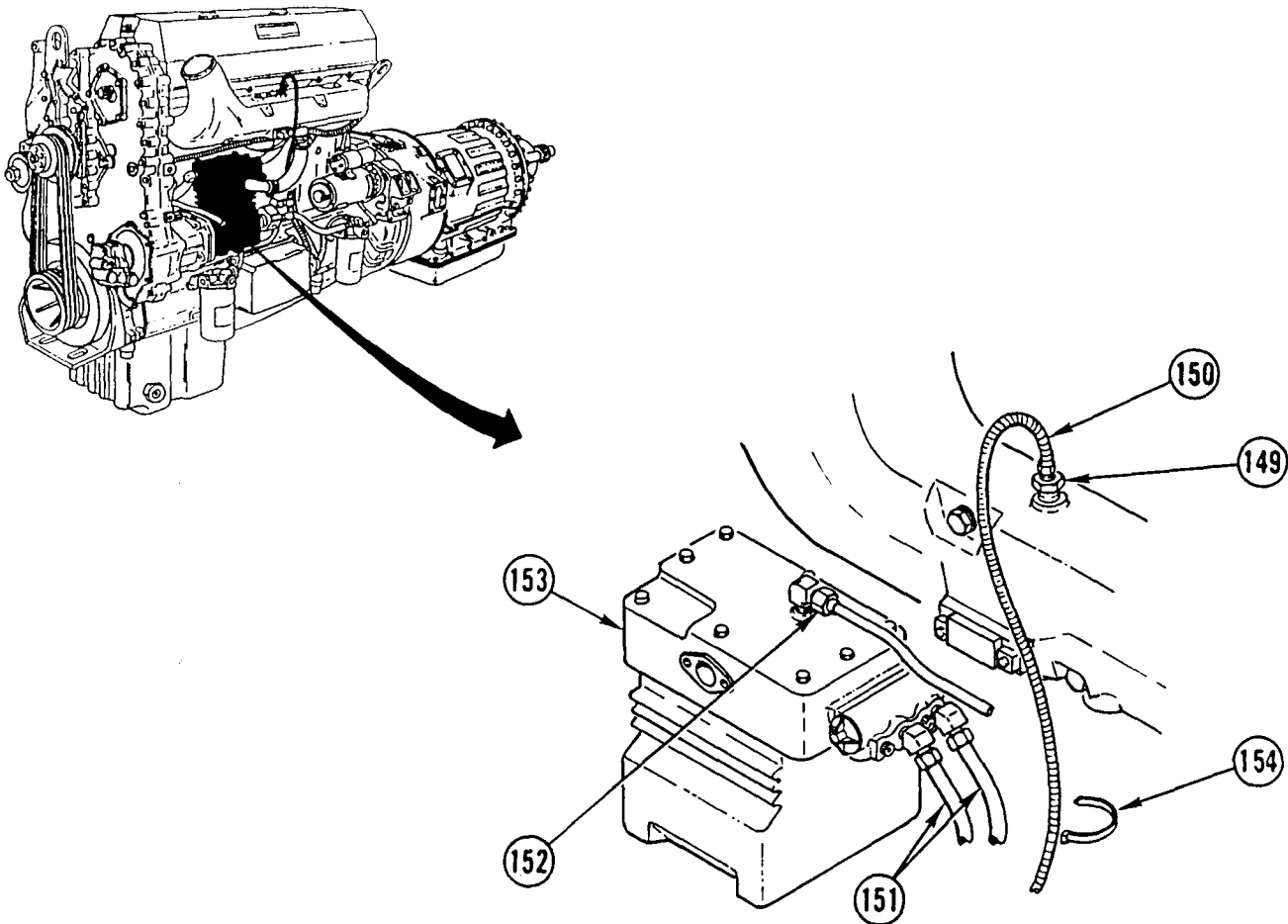

CAUTION
Make sure arrow on wrench flat of atomizer is facing either to front or rear of engine. Failure to do so will cause ether start to malfunction.

- 49. INSTALL ATOMIZER (149) AND TUBE (150).
- 50. CONNECT TWO TUBES (51) AND HOSE (152) TO AIR COMPRESSOR (53) AND INSTALL NEW WIRE TIE (154).

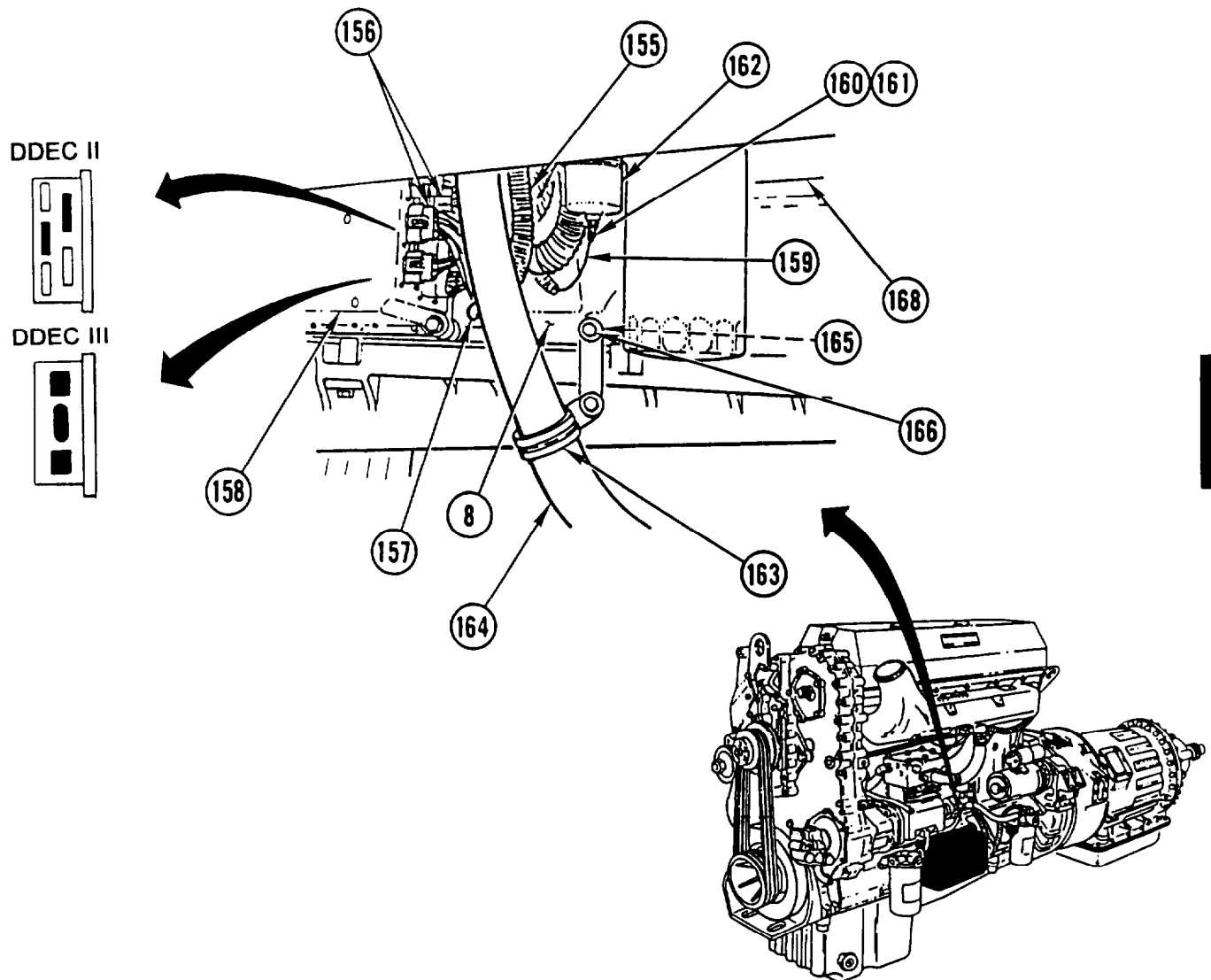

51. IF INSTALLING A DDEC II EQUIPPED ENGINE, POSITION HARNESS (155) AND CONNECT TWO PLUGS (156) AND CONNECTOR (157) TO ELECTRONIC CONTROL MODULE (158).
- 51.1 IF INSTALLING A DDEC III EQUIPPED ENGINE, CONNECT ELECTRONIC CONTROL MODULE POWER HARNESS(ES) TO CONNECTORS LOCATED AT REAR OF ECM.
- 51.2 SECURE HARNESS WITH TIE WRAPS.
52. INSTALL WIRE (159), WASHER (160), AND NUT (161) ON FUEL PRESSURE SENDING UNIT (162).
53. INSTALL BRACKET (163) ON CABLE HARNESS (164). INSTALL SPACER (165), BRACKET (163), AND SCREW (166) IN ENGINE (8).

ENGINE REPLACEMENT (CONT)

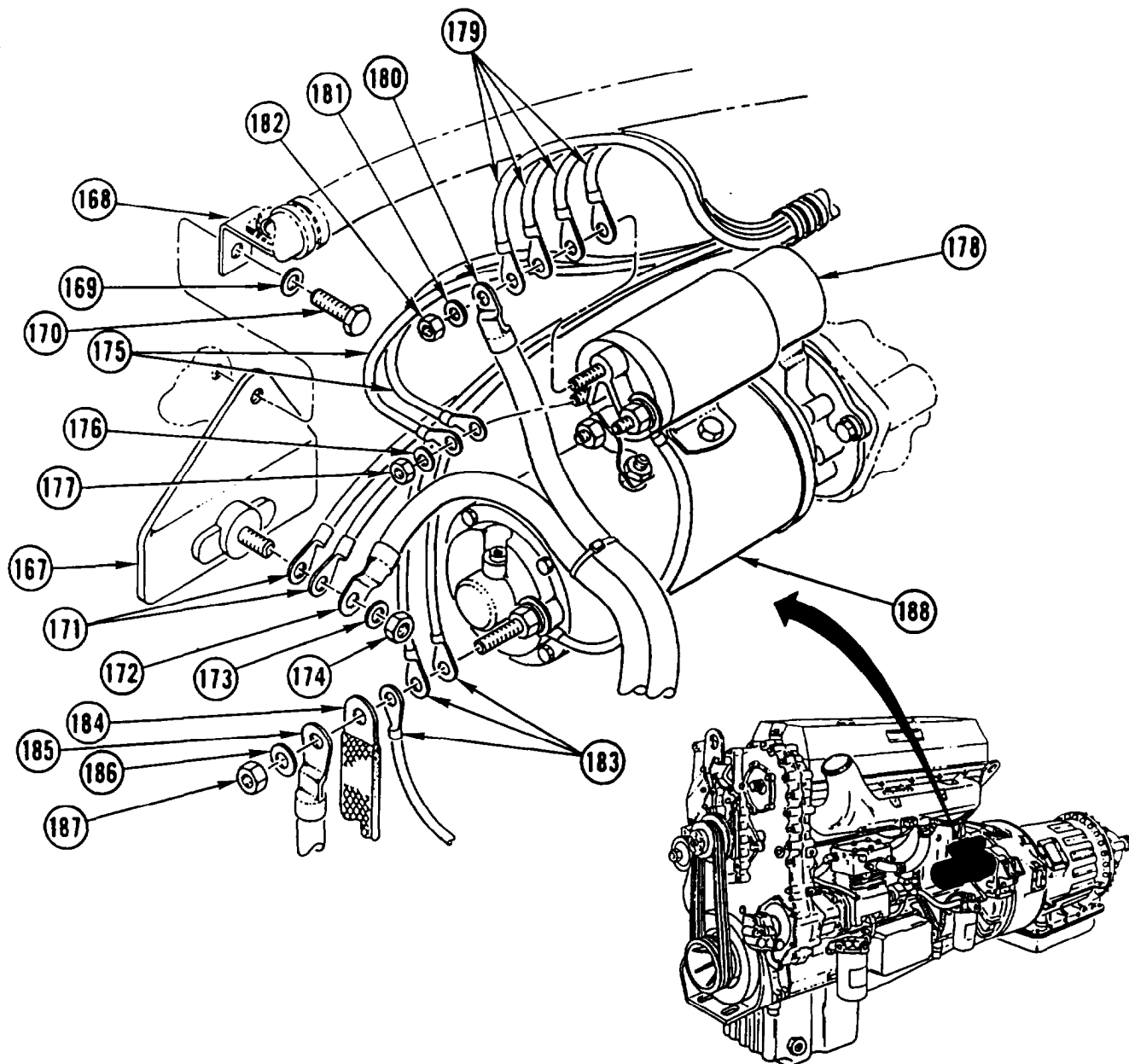

54. INSTALL PLATE (167), BRACKET (168), WASHER (169), AND SCREW (170).
55. CONNECT TWO WIRES (171) AND CABLE (172) AND INSTALL WASHER (173) AND NUT (174) ON PLATE (167).
56. CONNECT TWO WIRES (175) AND INSTALL WASHER (176) AND NUT (177) ON STARTER SOLENOID (178).
57. CONNECT FOUR WIRES (179) AND CABLE (180) AND INSTALL WASHER (181) AND NUT (182) ON STARTER SOLENOID (178).
58. CONNECT THREE WIRES (183), GROUND STRAP (184), AND CABLE (185). INSTALL WASHER (186) AND NUT (187) ON STARTER (188).

NOTE

Follow-on Maintenance:

- Install transfer case front output driveline (all except M915A2) (TM 9-2320-363-20).
- Install STE/ICE differential switch (TM 9-2320-363-20).
- Install oil sample valve (TM 9-2320-363-20).
- Install fender extensions (TM 9-2320-363-20).
- Install alternator and alternator adjusting rod (TM 9-2320-363-20).
- Install air conditioner compressor (page 11.1-9).
- Install alternator air conditioner belt (TM 9-2320-363-20).
- Install air cleaner, pre-cleaner, and duct assembly (TM 9-2320-363-20).
- Install air intake tubes, hoses, and clamps (TM 9-2320-363-20).
- Install tachometer drive unit (TM 9-2320-363-20).
- Install fan impeller and shroud (TM 9-2320-363-20).
- Install hood (TM 9-2320-363-20).
- Install transmission tunnel access cover (TM 9-2320-363-20).
- Fill engine with oil (TM 9-2320-363-20).

FRONT ENGINE MOUNT ADAPTER REPLACEMENT

This task covers: a. Removal b. Cleaning c. Inspection d. Installation

INITIAL SETUP

Tools and Special Equipment:

Shop Equipment, SC 4910-95-CL-A31
Tool Kit, SC 5180-90-CL-N05

Materials/Parts:

Nut, Lock (2)

Personnel Required: (2)

Equipment Condition:

Reference

Page 3-122

Condition Description

Vibration Damper
Removed

General Safety Instructions:

WARNING

Engine weighs 2,850 lb (1294 kg). Support engine from lower block pan rail. Failure to do so could result in injury to personnel and damage to equipment.

REMOVAL

1. REMOVE TWO LOCK NUTS (1), TWO WASHERS (2) TWO SCREWS (3), TWO WASHERS (4), TWO ISOLATORS (5), AND TWO SLEEVES (6) FROM FRONT ENGINE MOUNT ADAPTER (7). DISCARD LOCK NUTS.

WARNING

Engine weighs 2,850 lb (1294 kg). Support engine from lower block pan rail. Failure to do so could result in injury to personnel and damage to equipment.

2. SUPPORT ENGINE (8) AND REMOVE SPACER (9) AND TWO ISOLATORS (10).
3. REMOVE FOUR BOLTS (11) AND FRONT ENGINE MOUNT ADAPTER (7).

CLEANING

Use general cleaning methods to clean all parts (page 2-30).

INSPECTION

Inspect all parts for wear or damage.

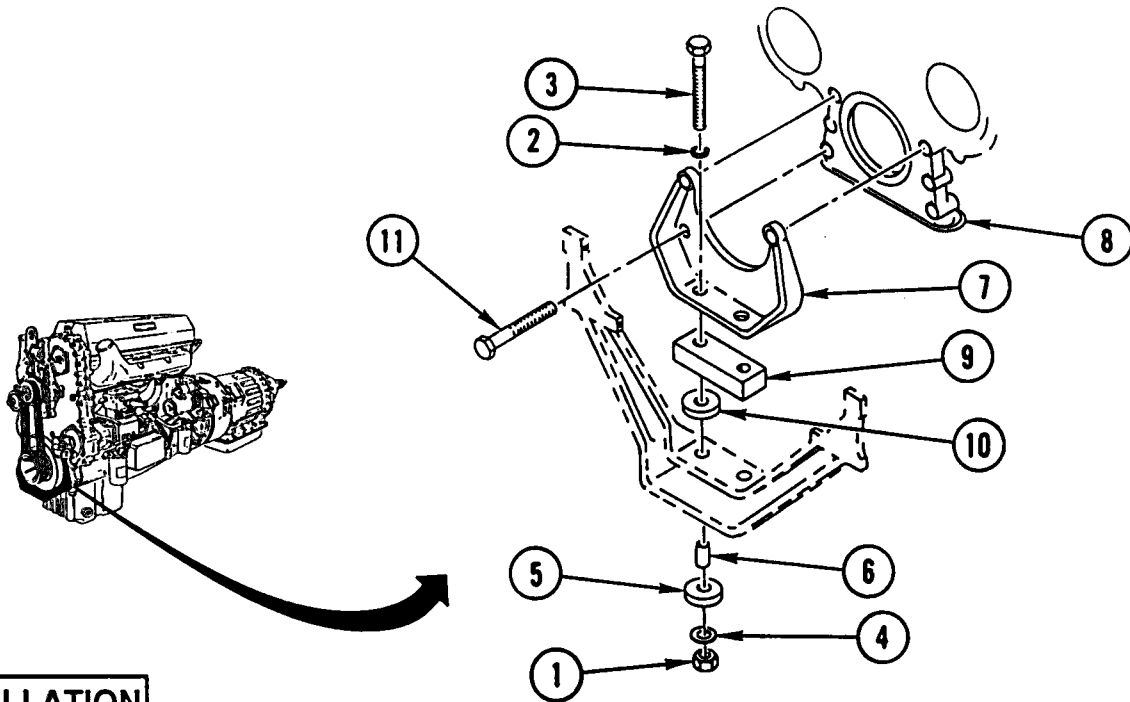

INSTALLATION

1. INSTALL FRONT ENGINE MOUNT ADAPTER (7) AND FOUR BOLTS (11).
2. INSTALL TWO ISOLATORS (10) AND SPACER (9).
3. LOWER ENGINE (8) AND REMOVE ENGINE SUPPORT.
4. INSTALL TWO SLEEVES (6), TWO ISOLATORS (5), TWO WASHERS (4), TWO SCREWS (3), TWO WASHERS (2), AND TWO NEW LOCK NUTS (1).

NOTE

Follow-on Maintenance:
Install vibration damper (page 3-122).

REAR ENGINE MOUNTS REPLACEMENT

This task covers: a. Removal b. Cleaning c. Inspection d. Installation

INITIAL SETUP

Applicable Configuration:

M915A2

Tools and Special Equipment:

Tool Kit, SC 5180-90-CL-N05

Materials/Parts:

Isolator (4) P/N CBA24-650-17

Nut , Lock

General Safety Instructions:

WARNING

Engine weighs 2,850 lb (1294 kg). Use hoist with lifting capacity of 5,000 lb (2270 kg) to lift and support engine. Failure to do so could result in injury to personnel.

REMOVAL

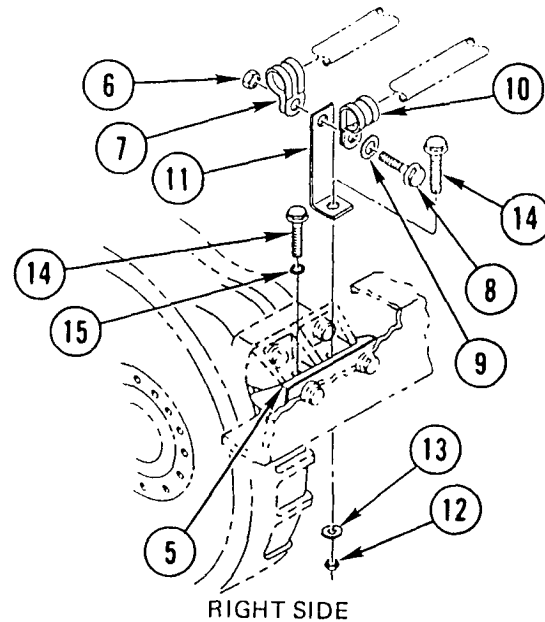
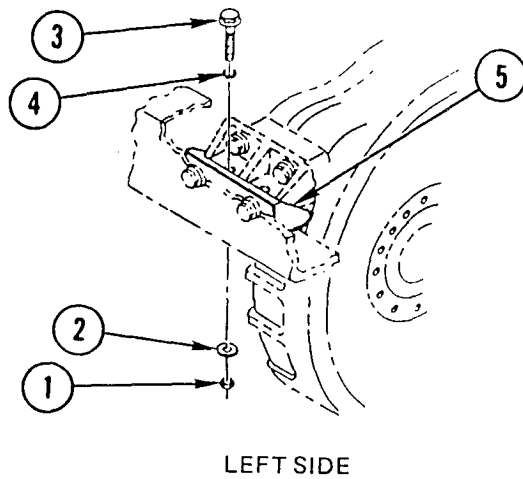

1. LEFT SIDE ONLY: REMOVE TWO NUTS (1), TWO WASHERS (2), TWO SCREWS (3), AND TWO WASHERS (4) FROM REAR ENGINE MOUNT (5).
2. RIGHT SIDE ONLY: REMOVE LOCK NUT (6), CLAMP (7), SCREW (8), WASHER (9), AND CLAMP (10) FROM BRACKET (11). DISCARD LOCK NUT.
3. RIGHT SIDE ONLY: REMOVE TWO NUTS (12), TWO WASHERS (13), TWO SCREWS (14), BRACKET (11), AND WASHER (15) FROM REAR ENGINE MOUNT (5).

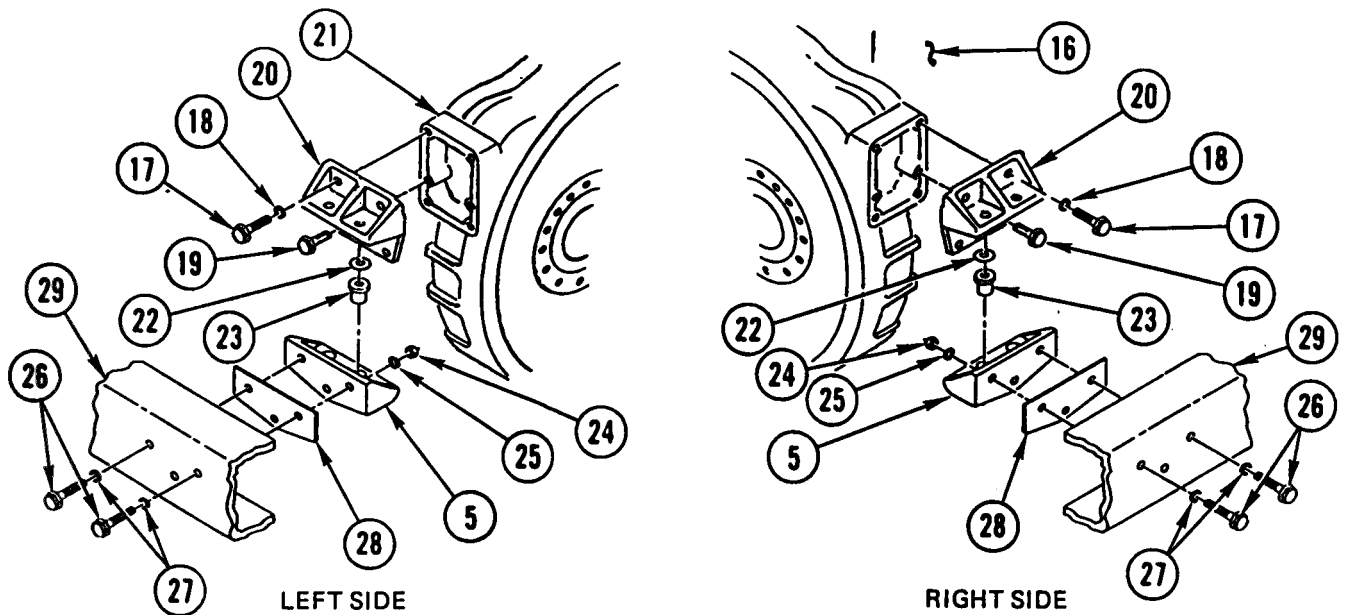

WARNING

Engine weighs 2,850 lb (1294 kg). Use hoist with lifting capacity of 5,000 lb (2270 kg) to lift and support engine. Failure to do so could result in injury to personnel.

CAUTION

Lift engine only enough to take weight off engine mounts. If engine is lifted too far, wiring harnesses may be crushed by cab crossmember.

4. USING SUITABLE LIFTING DEVICE, LIFT ENGINE (16) SLIGHTLY.

NOTE

Steps 5 thru 7 are for left side.

5. REMOVE TWO SCREWS (17), TWO WASHERS (18), TWO SCREWS (19), AND REAR ENGINE LEG (20) FROM FLYWHEEL HOUSING (21).
6. REMOVE TWO WASHERS (22) AND TWO ISOLATORS (23) FROM REAR ENGINE MOUNT (5).
7. REMOVE THREE NUTS (24), THREE WASHERS (25), THREE SCREWS (26), THREE WASHERS (27), REAR ENGINE MOUNT (5), AND SPACER (28) FROM FRAME (29).
8. REPEAT STEPS 5 THRU 7 FOR RIGHT SIDE.

REAR ENGINE MOUNTS REPLACEMENT (CONT)

CLEANING

Use general cleaning methods to clean all parts (page 2-30).

INSPECTION

Inspect all parts for wear or damage.

INSTALLATION

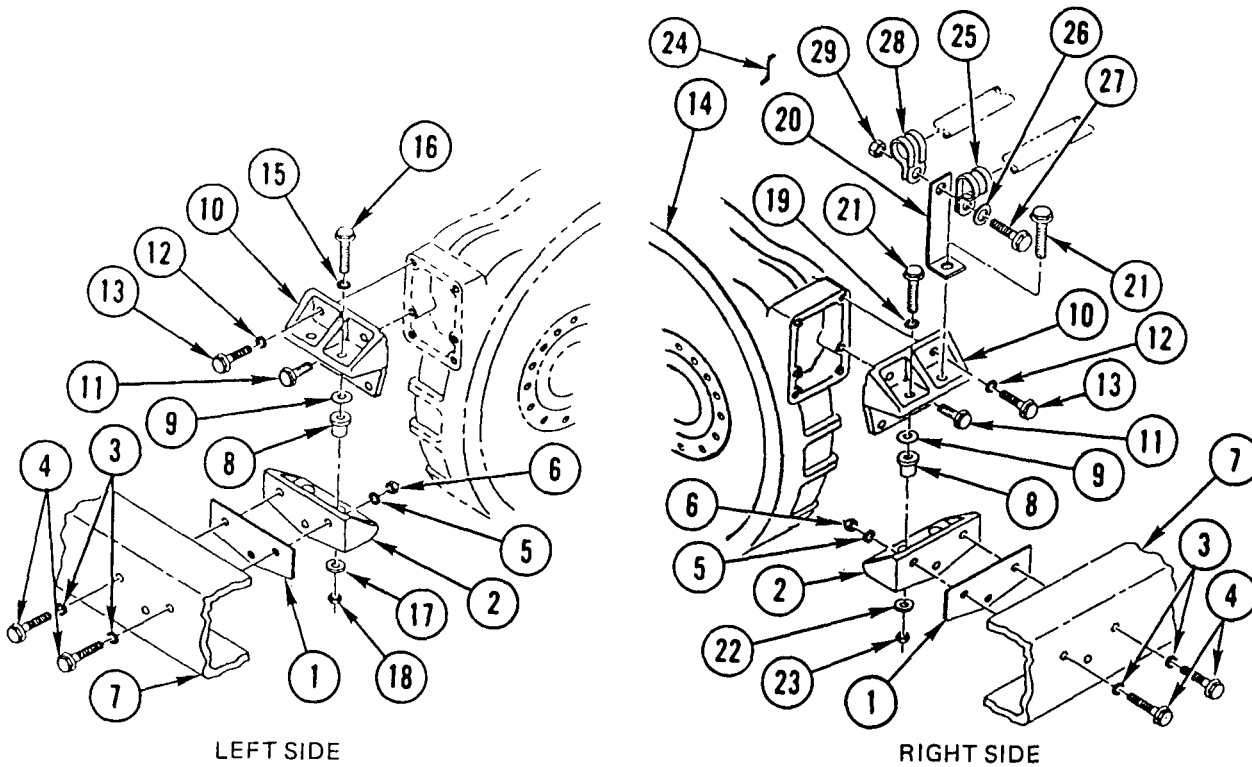

WARNING

Engine weighs 2,850 lb (1294 kg), Use hoist with lifting capacity of 5,000 lb (2270 kg) to lift and support engine. Failure to do so could result in injury to personnel.

NOTE

Steps 1 thru 3 are for right side.

1. INSTALL SPACER (1), REAR ENGINE MOUNT (2), THREE WASHERS (3), THREE SCREWS (4), THREE WASHERS (5), AND THREE NUTS (6) ON FRAME (7).
2. INSTALL TWO ISOLATORS (8) AND TWO WASHERS (9) IN REAR ENGINE MOUNT (2).
3. INSTALL REAR ENGINE LEG (10), TWO SCREWS (11), TWO WASHERS (12), AND TWO SCREWS (13) IN FLYWHEEL HOUSING (14).
4. REPEAT STEPS 1 THRU 3 FOR LEFT SIDE.
5. LEFT SIDE ONLY: INSTALL TWO WASHERS (15), TWO SCREWS (16), TWO WASHERS (17) AND TWO NUTS (18) HAND-TIGHT IN REAR ENGINE MOUNT (2).
6. RIGHT SIDE ONLY: INSTALL WASHER (19), BRACKET (20), TWO SCREWS (21), TWO WASHERS (22), AND TWO NUTS (23) ON REAR ENGINE MOUNT (2).
7. LOWER ENGINE (24) ONTO ENGINE MOUNTS AND TIGHTEN FOUR NUTS (18 and 23).
8. RIGHT SIDE ONLY: INSTALL CLAMP (25), WASHER (26), SCREW (27), CLAMP (28), AND NEW LOCK NUT (29) ON BRACKET (20).

REAR ENGINE MOUNTS REPLACEMENT

This task covers: a. Removal b. Cleaning c. inspection d. Installation

INITIAL SETUP

Applicable Configuration:

All except M915A2

Tools and Special Equipment:

Tool Kit, SC 5180-90-CL-N05

Materials/Parts:

Nut, Lock

General Safety Instructions:

WARNING

- Engine weighs 2,850 lb (1294 kg). Use hoist with lifting capacity of 5,000 lb (2270 kg) to lift and support engine. Failure to do so could result in injury to personnel.
- Cab weighs 1,100 lb (499 kg). Use suitable jack stands to support cab. Failure to do so could result in serious injury to personnel.

REMOVAL

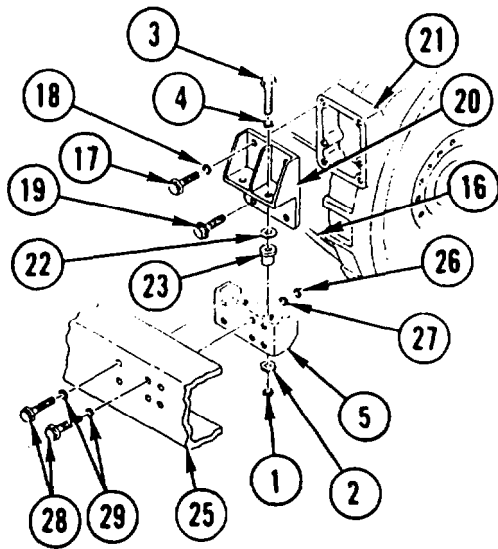

LEFT SIDE

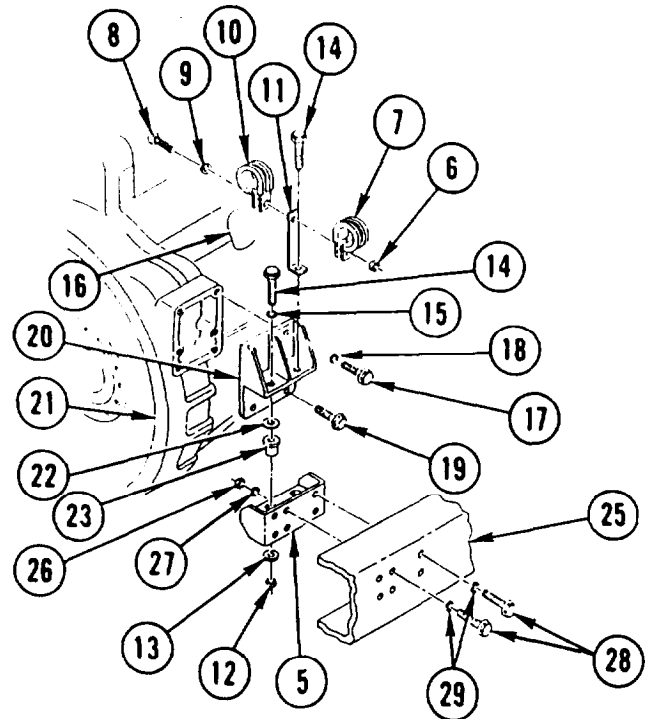

RIGHT SIDE

1. LEFT SIDE ONLY: REMOVE TWO NUTS (1), TWO WASHERS (2), TWO SCREWS (3), AND TWO WASHERS (4) FROM REAR ENGINE MOUNT (5).

2. RIGHT SIDE ONLY: REMOVE LOCK NUT (6), CLAMP (7), SCREW (8), WASHER (9), AND CLAMP (10) FROM BRACKET (11). DISCARD LOCK NUT.
3. RIGHT SIDE ONLY: REMOVE TWO NUTS (12), TWO WASHERS (13), TWO SCREWS (14), BRACKET (11), AND WASHER (15) FROM REAR ENGINE MOUNT (5).

WARNING

Engine weighs 2,850 lb (1294 kg). Use hoist with lifting capacity of 5,000 lb (2270 kg) to lift and support engine. Failure to do so could result in injury to personnel.

CAUTION

Lift engine only enough to take weight off engine mounts. If engine is lifted too far, wiring harnesses may be crushed by cab crossmember.

4. USING SUITABLE LIFTING DEVICE, LIFT ENGINE (16) SLIGHTLY.

NOTE

Steps 5, 6, and 8 are for left side.

5. REMOVE TWO SCREWS (17), TWO WASHERS (18), TWO SCREWS (19), AND REAR ENGINE LEG (20) FROM FLYWHEEL HOUSING (21).
6. REMOVE TWO WASHERS (22) AND TWO ISOLATORS (23) FROM REAR ENGINE MOUNT (5).

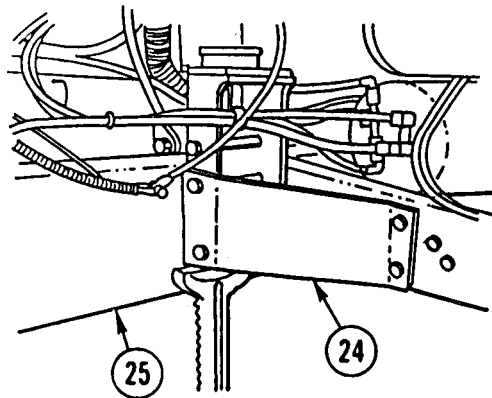

WARNING

Cab weighs 1,100 lb (499 kg). Use suitable jack stands to support cab. Failure to do so could result in serious injury to personnel.

7. USING SUITABLE JACK STANDS, SUPPORT CAB AT CAB MOUNTS (24) AS CLOSE TO FRAME RAIL (25) AS POSSIBLE.
8. REMOVE SIX NUTS (26), SIX WASHERS (27), SIX SCREWS (28), SIX WASHERS (29), AND REAR ENGINE MOUNT (5) FROM FRAME RAIL (25).
9. REPEAT STEPS 5, 6, AND 8 FOR RIGHT SIDE.

REAR ENGINE MOUNTS REPLACEMENT (CONT)

CLEANING

Use general cleaning methods to clean all parts (page 2-30).

INSPECTION

Inspect all parts for wear or damage.

INSTALLATION

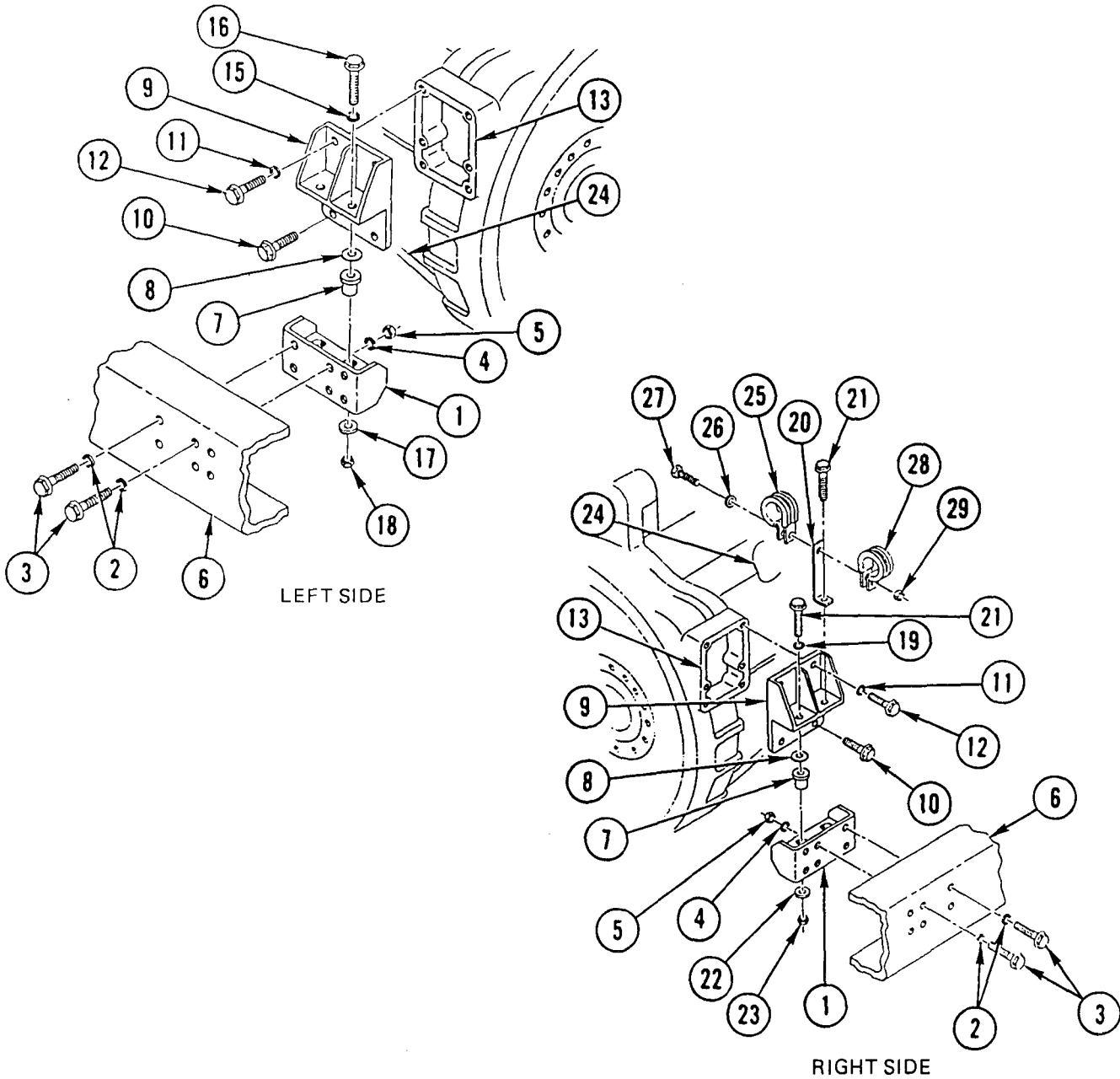

WARNING

Engine weighs 2,850 lb (1294 kg). Use hoist with lifting capacity of 5,000 lb (2270 kg) to lift and support engine. Failure to do so could result in injury to personnel.

NOTE

Steps 1 thru 3 are for right side.

1. INSTALL REAR ENGINE MOUNT (1), SIX WASHERS (2), SIX SCREWS (3), SIX WASHERS (4), AND SIX NUTS (5) ON FRAME RAIL (6).
2. INSTALL TWO ISOLATORS (7) AND TWO WASHERS (8) IN REAR ENGINE MOUNT (1).
3. INSTALL REAR ENGINE LEG (9), TWO SCREWS (10), TWO WASHERS (11), AND TWO SCREWS (12) IN FLYWHEEL HOUSING (13).
4. REPEAT STEPS 1 THRU 3 FOR LEFT SIDE.

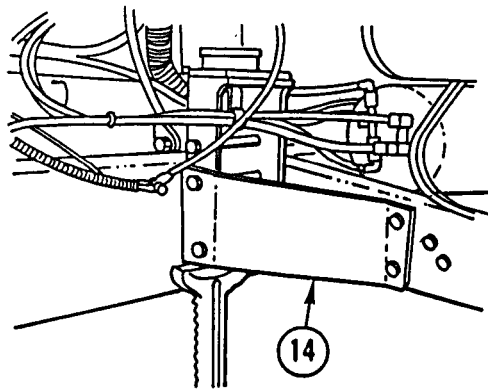

5. REMOVE JACK STANDS FROM CAB MOUNTS (14).
6. LEFT SIDE ONLY: INSTALL TWO WASHERS (15), TWO SCREWS (16), TWO WASHERS (17), AND TWO NUTS (18) HAND-TIGHT IN REAR ENGINE MOUNT (1).
7. RIGHT SIDE ONLY: INSTALL WASHER (19), BRACKET (20), TWO SCREWS (21), TWO WASHERS (22), AND TWO NUTS (23) ON REAR ENGINE MOUNT (1).
8. LOWER ENGINE (24) ONTO ENGINE MOUNTS AND TIGHTEN FOUR NUTS (18 and 23).
9. RIGHT SIDE ONLY: INSTALL CLAMP (25), WASHER (26), SCREW (27), CLAMP (28), AND NEW LOCK NUT (29) ON BRACKET (20).

FAN DRIVE SUPPORT REPLACEMENT

This task covers: a. Removal b. Cleaning c. Inspection d. installation

INITIAL SETUP

Tools and Special Equipment:

Shop Equipment, SC 4910-95-CL-A31
Tool Kit, SC 5180-90-CL-N05
Caulking Gun, 805774

References:

TM 9-2320-363-20

Equipment Condition:

Materials/Parts:

Eliminator, Gasket Appendix B, Item 18

Reference

TM 9-2320-363-20

Condition Description

Spindle and Housing
Assembly Removed

REMOVAL

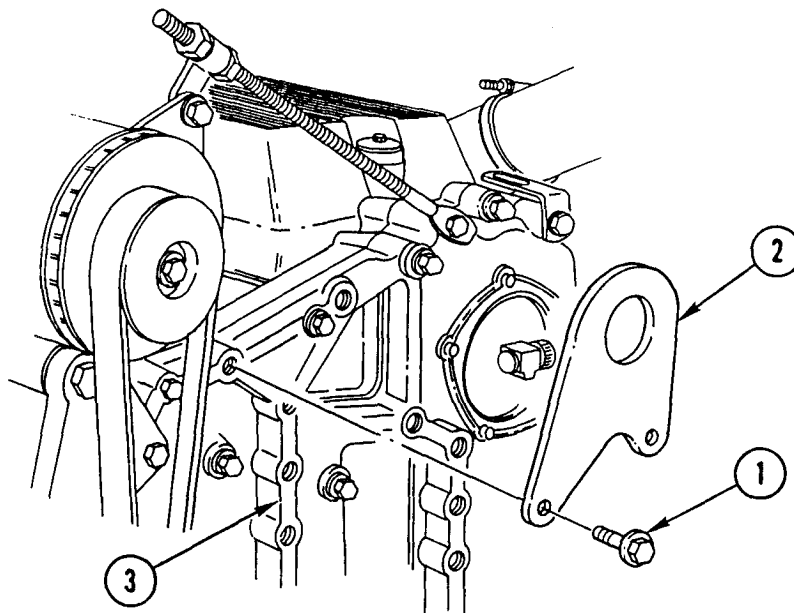

NOTE

If repairing an oil leak, do not remove lifter bracket.

1. REMOVE TWO BOLTS (1) AND FRONT ENGINE LIFTER BRACKET (2) FROM FAN SUPPORT BRACKET (3).

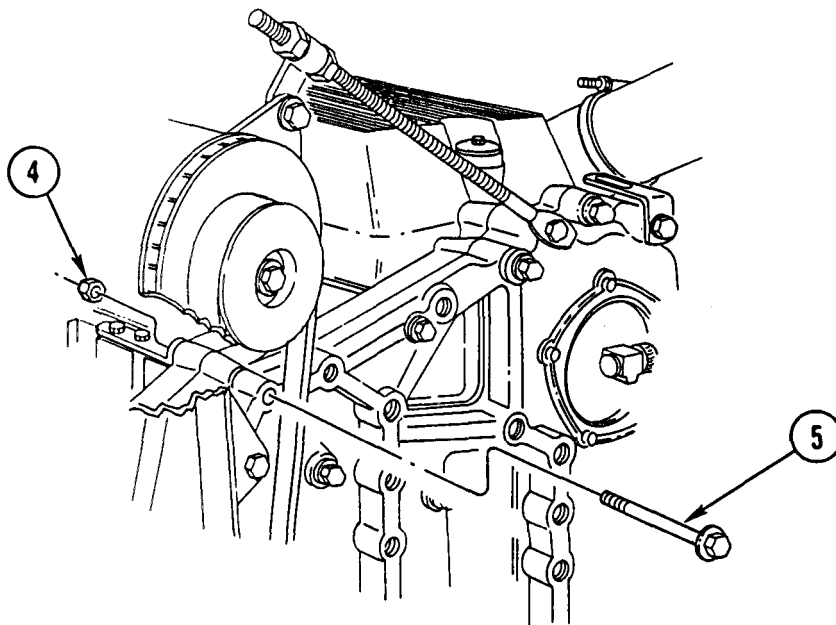

2. HOLD NUT (4) AND REMOVE GEAR HOUSING STABILIZER BRACKET BOLT (5).
3. REMOVE NUT (4).

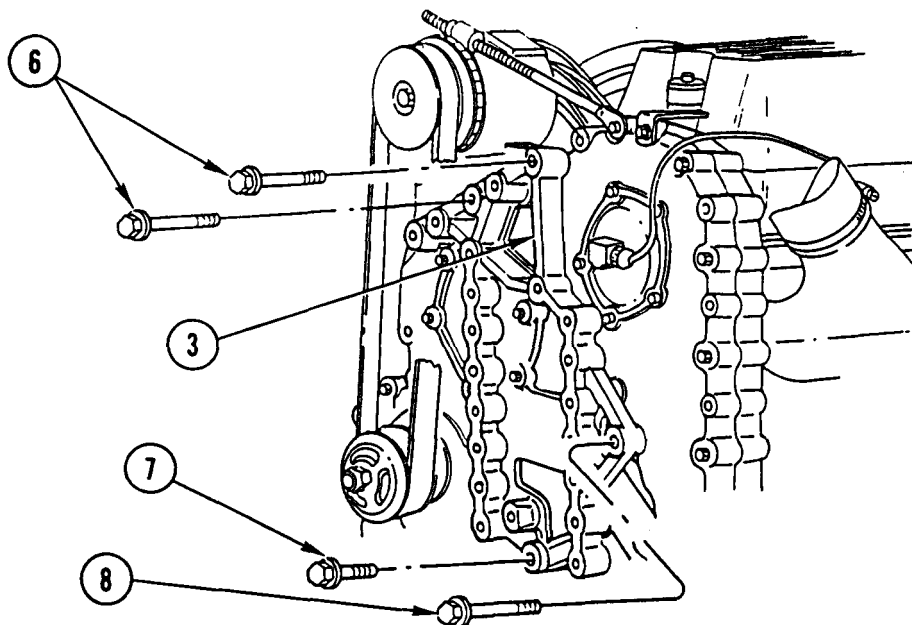

4. REMOVE TWO BOLTS (6) AT TOP OF FAN SUPPORT BRACKET (3).
5. REMOVE SHORT BOLT (7) AT BOTTOM OF FAN SUPPORT BRACKET (3).
6. REMOVE LONG BOLT (8) AT RIGHT SIDE OF FAN SUPPORT BRACKET (3).

FAN DRIVE SUPPORT REPLACEMENT (CONT)

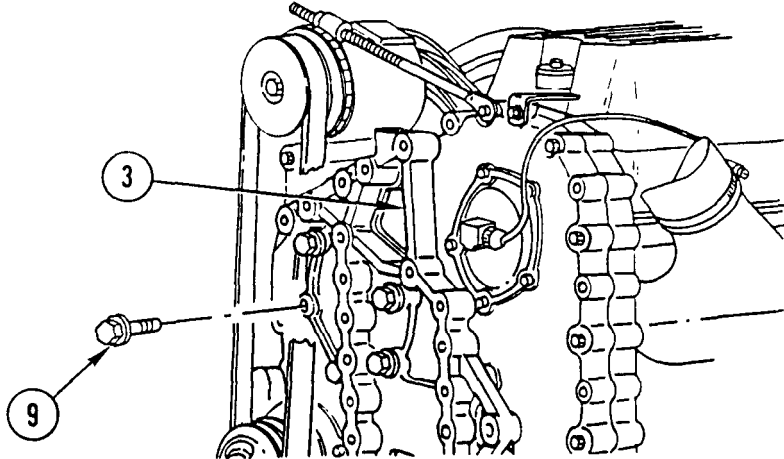

7. REMOVE FIVE ADJUSTABLE IDLER GEAR COVER BOLTS (9).
8. USING PLASTIC OR FIBER Mallet, TAP FAN SUPPORT BRACKET (3) TO BREAK LOOSE.

CLEANING

1. CLEAN ALL OLD GASKET ELIMINATOR MATERIAL FROM GEAR CASE COVER AND ADJUSTABLE IDLER GEAR COVER MATING SURFACES.
2. USE GENERAL CLEANING METHODS TO CLEAN ALL PARTS (PAGE 2-30).

INSPECTION

Inspect all parts for wear or damage.

INSTALLATION

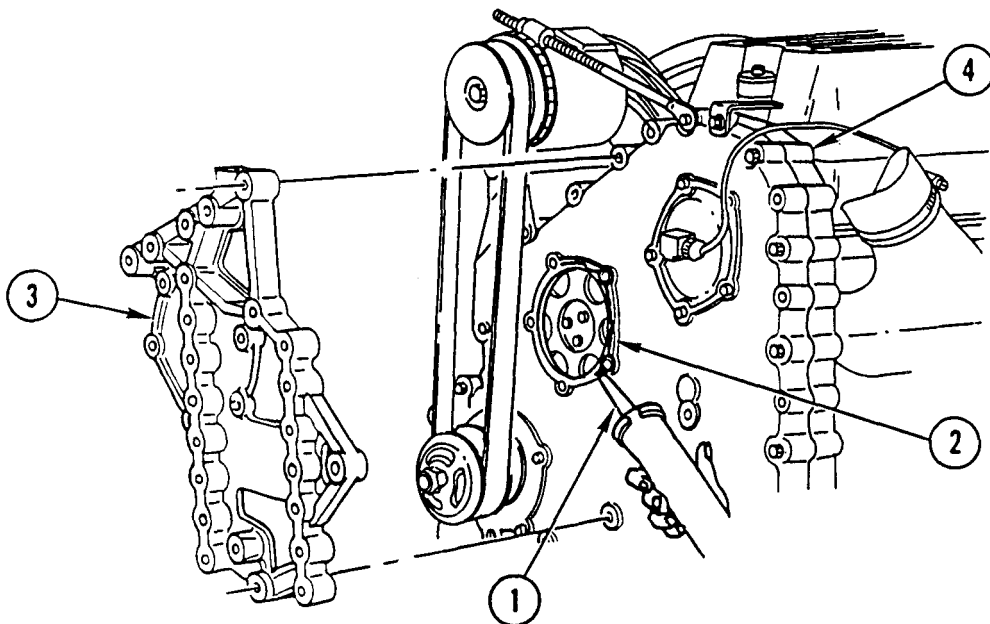

1. USING CAULKING GUN, APPLY 1/16-IN. BEAD OF GASKET ELIMINATOR (1) TO MACHINED SURFACE (2) OF ADJUSTABLE IDLER ACCESS HOLE AND POSITION FAN SUPPORT BRACKET (3) ON GEAR CASE COVER (4).

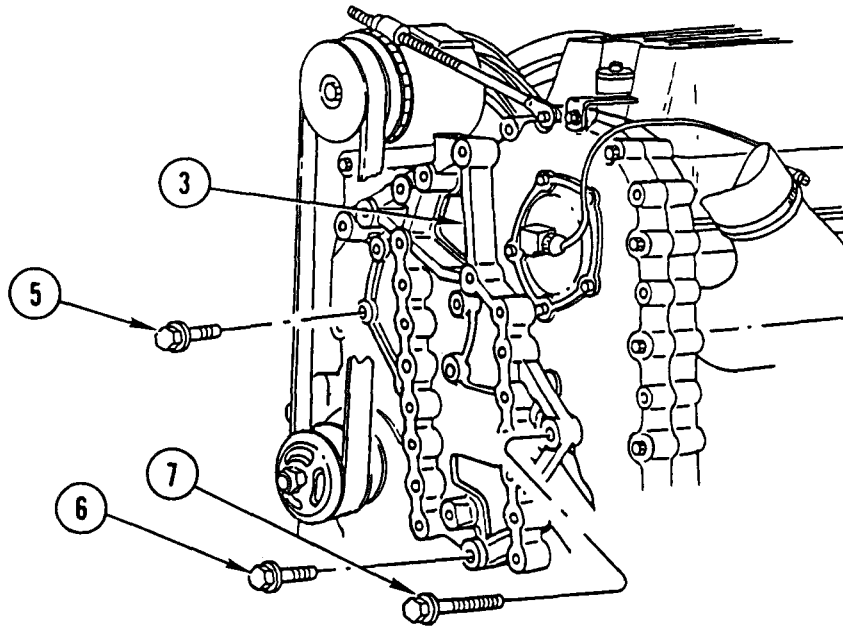

2. INSTALL FIVE ADJUSTABLE IDLER GEAR COVER BOLTS (5) HAND-TIGHT.
3. INSTALL SHORT BOLT (6) THRU BOTTOM HOLE IN FAN SUPPORT BRACKET (3) AND LONG BOLT (7) THRU RIGHT-HAND BOLT HOLE. TIGHTEN BOLTS (6 AND 7) TO 118-148LB-FT (160-200 N.m).

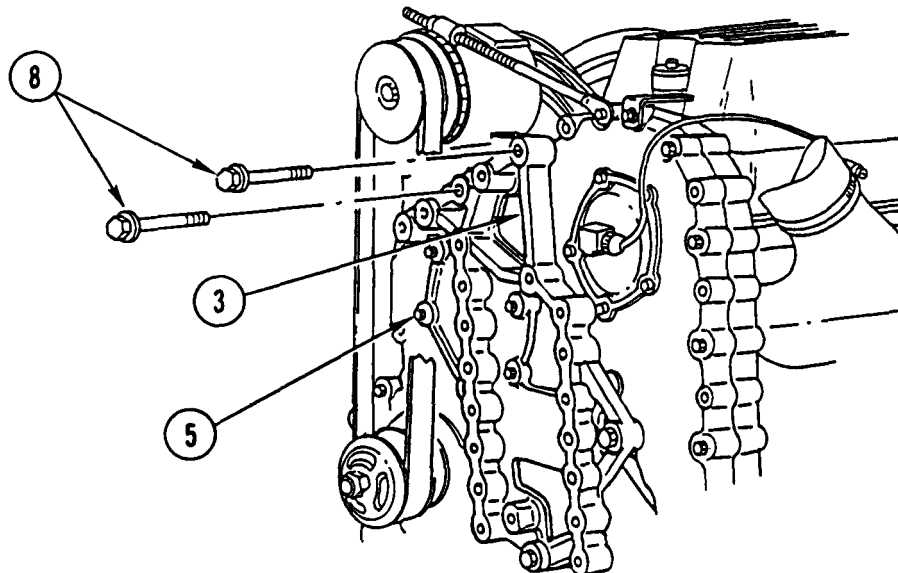

4. INSTALL TWO BOLTS (8) THRU BOLT HOLES AT TOP OF FAN SUPPORT BRACKET (3). TIGHTEN BOLTS TO 43-54 LB-FT (58-73 N.m).
5. TIGHTEN FIVE ADJUSTABLE IDLER GEAR COVER BOLTS (5) TO 22-28 LB-FT (30-38 N.m).

FAN DRIVE SUPPORT REPLACEMENT (CONT)

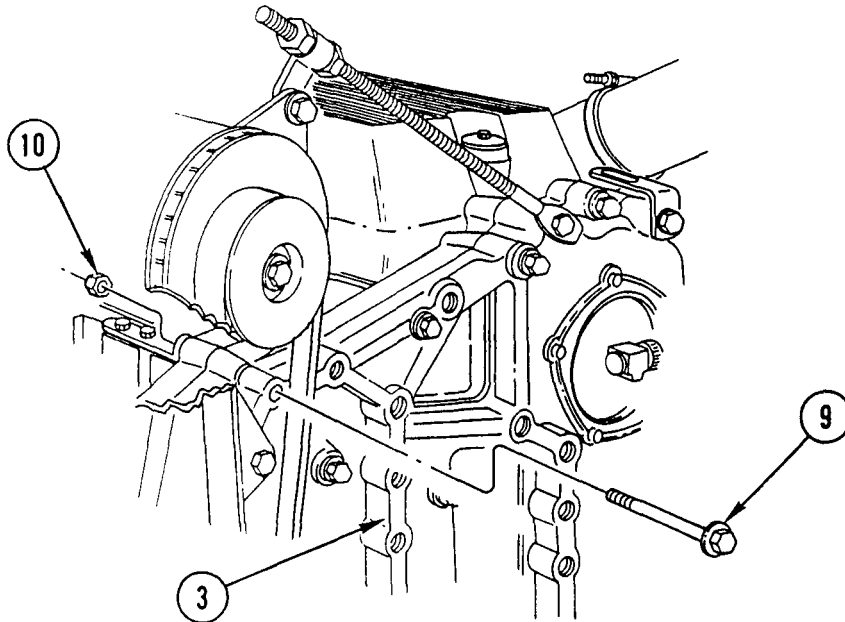

6. INSTALL BOLT (9) THRU TOP LEFT-HAND BOLT HOLE IN FAN SUPPORT BRACKET (3) AND THRU GEAR HOUSING STABILIZER BRACKET.
7. INSTALL NUT (10). HOLD NUT AND TIGHTEN BOLT (9) TO 43-54 LB-FT (58-73 N.m).

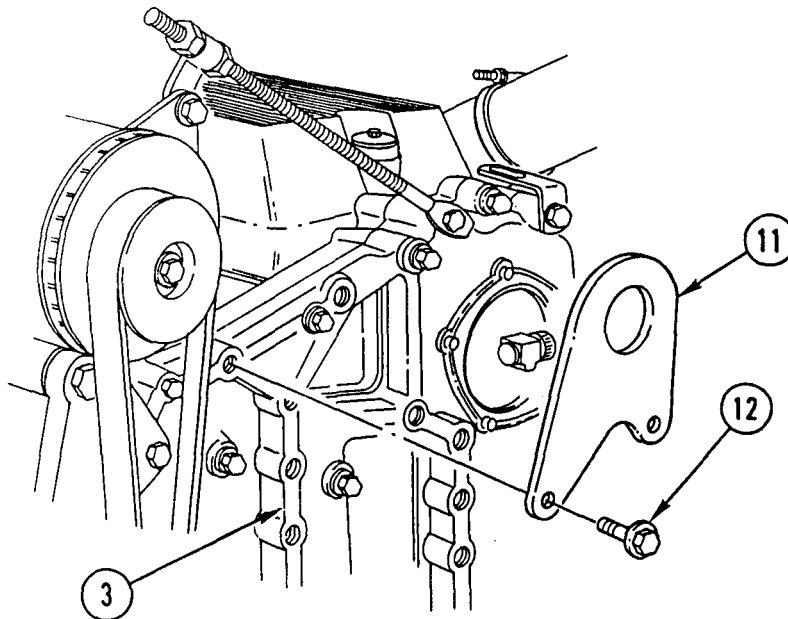

8. POSITION FRONT ENGINE LIFTING BRACKET (11) ON FAN SUPPORT BRACKET (3) AND INSTALL TWO BOLTS (12). TIGHTEN BOLTS TO 75-93 LB-FT (101-126 N.m).

NOTE

Follow-on Maintenance:
Install spindle and housing assembly (TM 9-2320-363-20).

AIR INTAKE MANIFOLD REPLACEMENT

This task covers: a. Removal b. Cleaning c. Inspection d. Installation

INITIAL SETUP

Applicable Configuration:

M915A2 and M916A1

Tools and Special Equipment:

Shop Equipment, SC 4910-95-CL-A31
 Tool Kit, SC 5180-90-CL-N05
 Guide, Stud (2), J36107
 Caulking Gun, 805774

Materials/Parts:

Ring, Seal	P/N 5182977
Eliminator, Gasket	Appendix 6, Item 18
Oil, Lubricating	Appendix B, Item 37
Compound, Pipe Sealing	Appendix B, Item 15

References:

TM 9-2320-363-20

Equipment Description:

Reference	Condition Description
TM 9-2320-363-20	Air Intake Manifold to Intercooler Tube Removed
TM 9-2320-363-20	Ether Atomizer and Bushing Removed
TM 9-2320-363-20	Batteries Disconnected

General Safety Instructions:

WARNING

Make sure all air lines and fittings are clear of debris. Make sure excess pipe sealing compound does not enter air lines or fittings. Failure to do so could result in equipment failure and/or injury to personnel.

REMOVAL

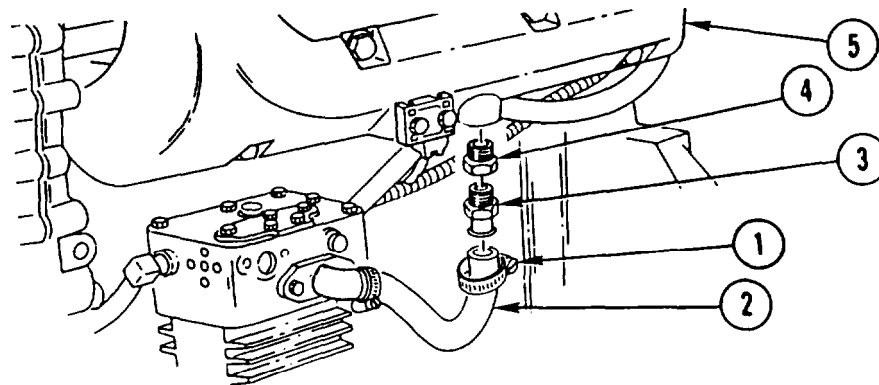

1. LOOSEN HOSE CLAMP (1) AND DISCONNECT AIR COMPRESSOR INLET HOSE (2) FROM AIR SUPPLY CONNECTOR (3).
2. REMOVE AIR SUPPLY CONNECTOR (3) AND REDUCER (4) FROM AIR INTAKE MANIFOLD (5).

AIR INTAKE MANIFOLD REPLACEMENT (CONT)

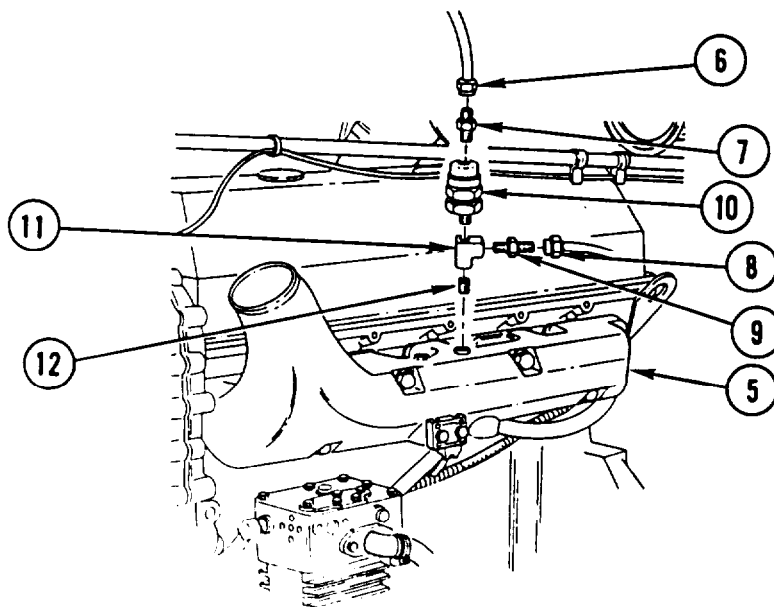

3. DISCONNECT AIR LINE CONNECTOR (6) FROM NIPPLE (7).
4. DISCONNECT AIR LINE CONNECTOR (8) FROM NIPPLE (9).
5. REMOVE TWO NIPPLES (7 AND 9), CHECK VALVE (10), TEE (11), AND NIPPLE (12) FROM AIR INTAKE MANIFOLD (5).

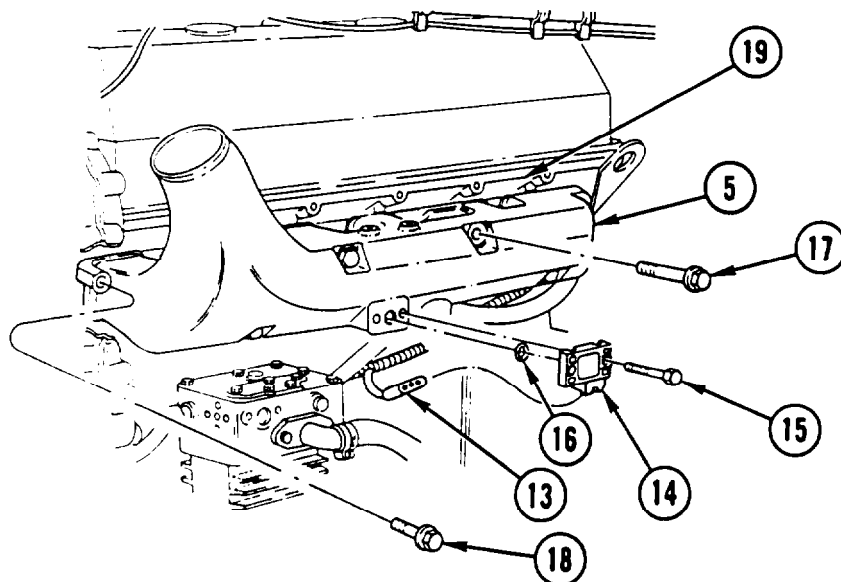

6. DISCONNECT ENGINE WIRING HARNESS (13) FROM TURBO BOOST SENSOR (14).
7. REMOVE TWO RETAINING BOLTS (15) AND TURBO BOOST SENSOR (14).
8. REMOVE AND DISCARD SEAL RING (16).
9. REMOVE FIVE LONG BOLTS (17) AND TWO SHORT BOLTS (18) FROM AIR INTAKE MANIFOLD (5).

- IF NECESSARY, USE BRASS DRIFT AND TAP AIR INTAKE MANIFOLD (5) LIGHTLY TO LOOSEN FROM CYLINDER HEAD (19). REMOVE AIR INTAKE MANIFOLD (5).

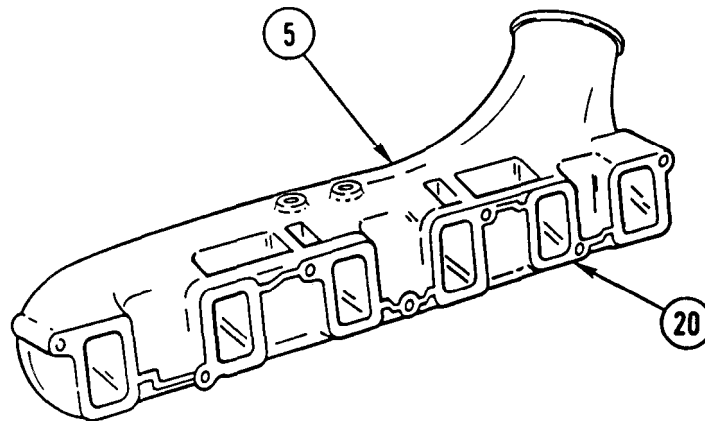

- REMOVE GASKET ELIMINATOR FROM MATING SURFACES (20) OF AIR INTAKE MANIFOLD (5) AND CYLINDER HEAD.

CLEANING

Use general cleaning methods to clean all parts (page 2-30).

INSPECTION

- INSPECT EXHAUST MANIFOLD FOR CRACKS, PARTICULARLY IN MOUNTING BOLT BOSS AREAS. IF CRACKED, DISCARD EXHAUST MANIFOLD SECTION.
- INSPECT ALL PARTS FOR WEAR OR DAMAGE.

INSTALLATION

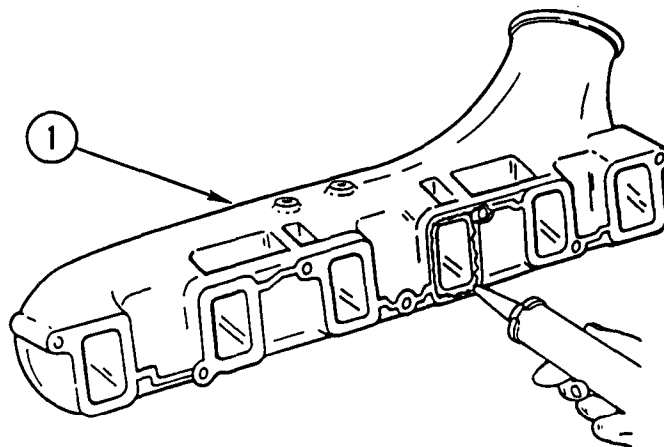

WARNING

Make sure all air lines and fittings are clear of debris. Make sure excess pipe sealing compound does not enter air lines or fittings. Failure to do so could result in equipment failure and/or injury to personnel.

- USING CAULKING GUN, APPLY 1/16 IN. CONTINUOUS BEAD OF GASKET ELIMINATOR TO MATING SURFACE OF AIR INTAKE MANIFOLD (1).

AIR INTAKE MANIFOLD REPLACEMENT (CONT)

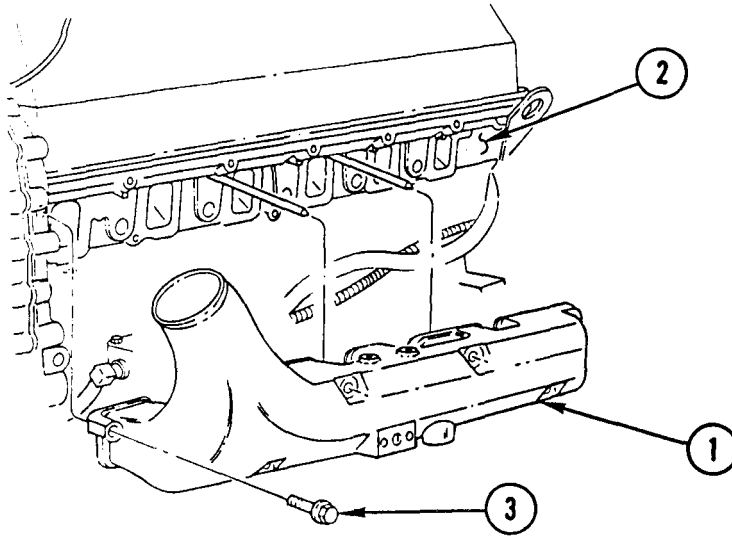

2. INSTALL TWO GUIDE STUDS IN UPPER CENTER BOLT HOLES OF CYLINDER HEAD (2).

NOTE

Make sure all wires are clear of intake manifold connection points before installing manifold.

3. INSTALL AIR INTAKE MANIFOLD (1) OVER TWO GUIDE STUDS AND AGAINST CYLINDER HEAD (2).
4. INSTALL TWO SHORT BOLTS (3) HAND-TIGHT IN AIR INTAKE MANIFOLD (1) (ONE ON EACH END).
5. REMOVE GUIDE STUDS.

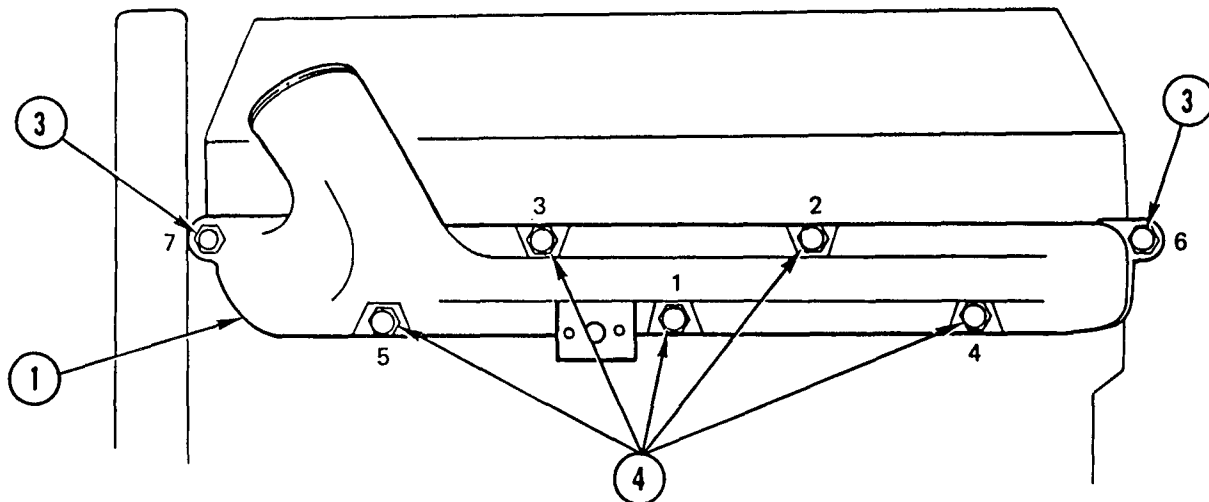

6. INSTALL FIVE LONG BOLTS (4) HAND-TIGHT IN AIR INTAKE MANIFOLD (1).
7. TIGHTEN SEVEN BOLTS (3 AND 4) TO 43-54 LB-FT (58-73 N.m) IN SEQUENCE SHOWN.

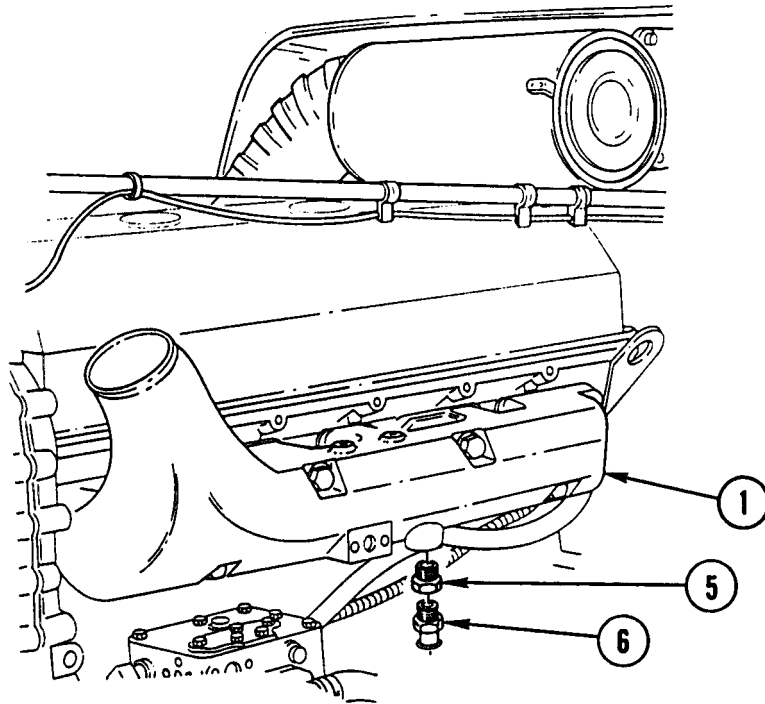

8. COAT THREADS OF REDUCER (5) WITH SEALING COMPOUND AND INSTALL REDUCER (5) IN AIR INTAKE MANIFOLD (1).
9. COAT THREADS OF AIR SUPPLY CONNECTOR (6) WITH SEALING COMPOUND AND INSTALL AIR SUPPLY CONNECTOR (6) IN REDUCER (5).

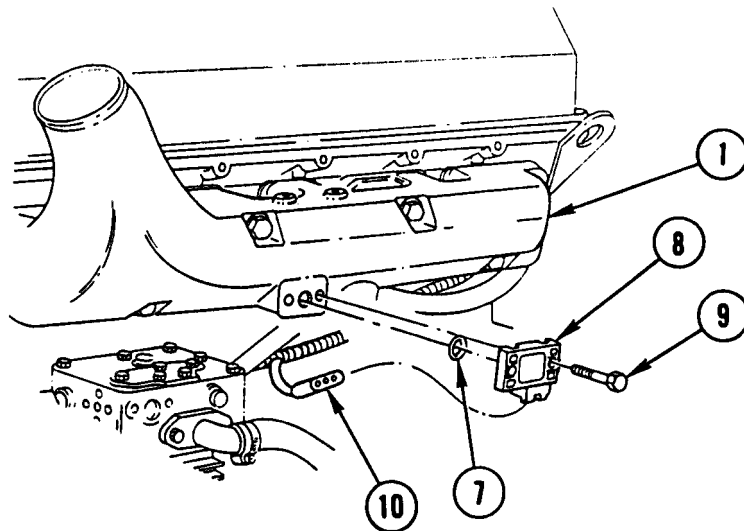

10. COAT NEW SEAL RING (7) WITH LUBRICATING OIL AND INSTALL SEAL RING (7) IN AIR INTAKE MANIFOLD (1).
11. INSTALL TURBO BOOST SENSOR (8) AND TWO RETAINING BOLTS (9) IN AIR INTAKE MANIFOLD (1). TIGHTEN BOLTS TO 21-26 LB-FT (2.4-2.9 N.m).
12. CONNECT ENGINE WIRING HARNESS (10) TO TURBO BOOST SENSOR (8).

AIR INTAKE MANIFOLD REPLACEMENT (CONT)

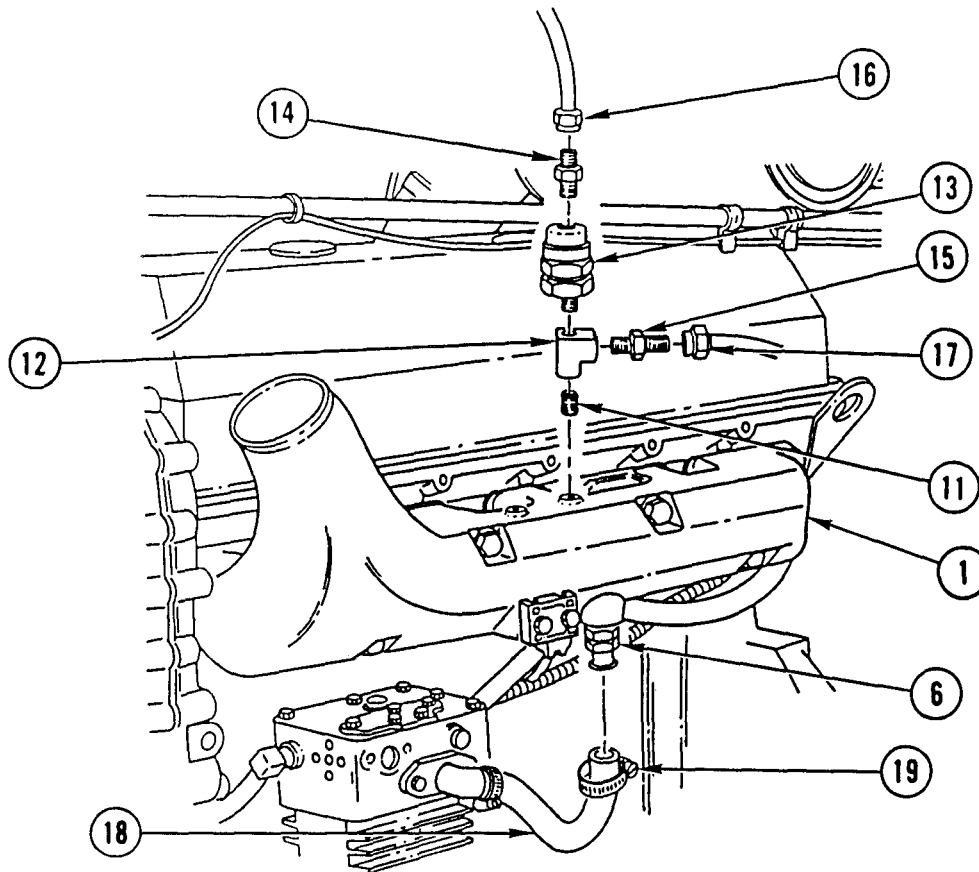

CAUTION

Do not use lubricant on inside of air compressor inlet hose, on hose contact surfaces of intercooler ducting, or on air intake manifold. Lubricant can cause hose to blow off when turbocharger builds up pressure.

13. COAT THREADS OF NIPPLE (11) WITH SEALING COMPOUND AND INSTALL NIPPLE (11), TEE (12), CHECK VALVE (13), AND TWO NIPPLES (14 AND 15) IN AIR INTAKE MANIFOLD (1).
14. CONNECT AIR LINE CONNECTOR (16) TO NIPPLE (14).
15. CONNECT AIR LINE CONNECTOR (17) TO NIPPLE (15).
16. CONNECT AIR COMPRESSOR INLET HOSE (18) TO AIR SUPPLY CONNECTOR (6).
17. POSITION AND TIGHTEN HOSE CLAMP (19).

NOTE

Follow-on Maintenance:

Install air intake manifold to intercooler tube (TM 9-2320-363-20).
Install ether atomizer and bushing (TM 9-2320-363-20).
Connect batteries (TM 9-2320-363-20).

AIR INTAKE MANIFOLD REPLACEMENT

This task covers: a. Removal b. Cleaning c. Inspection d. Installation

INITIAL SETUP

Applicable Configuration:

All except M915A2 and M916A1

Tools and Special Equipment:

Shop Equipment, SC 4910-95CL-A31
 Tool Kit, SC 5180-90-CL-N05

Materials/Parts:

- | | |
|------------------------|---------------------|
| Ring, Seal | P/N 5182977 |
| Gasket (2) | P/N 23514622 |
| Oil, Lubricating | Appendix B, Item 37 |
| Compound, Pipe Sealing | Appendix B, Item 15 |

References:

TM 9-2320-363-20

Equipment Description:

Reference	Condition	Description
TM 9-2320-363-20	Air Intake Manifold to Intercooler Tube Removed	
TM 9-2320-363-20	Batteries Disconnected	

General Safety Instructions:

WARNING

Make sure all air lines and fittings are clear of debris. Make sure excess pipe sealing compound does not enter air lines or fittings. Failure to do so could result in equipment failure and/or injury to personnel.

REMOVAL

1. LOOSEN HOSE CLAMP (1) AND DISCONNECT AIR COMPRESSOR INLET HOSE (2) FROM AIR SUPPLY CONNECTOR (3).
2. REMOVE AIR SUPPLY CONNECTOR (3) AND REDUCER (4) FROM AIR INTAKE MANIFOLD (5).

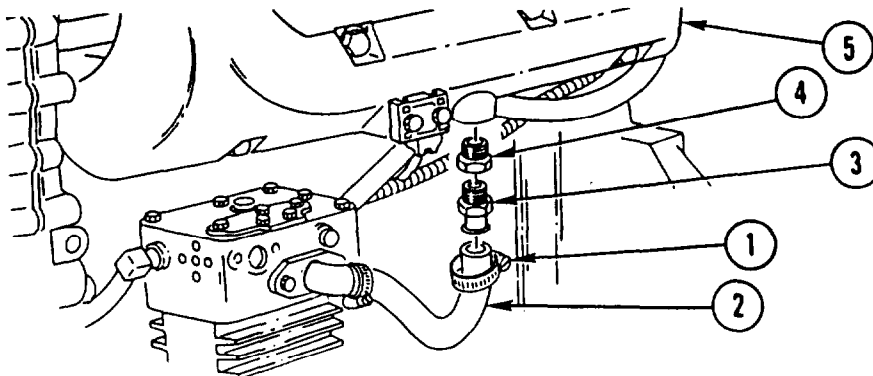

AIR INTAKE MANIFOLD REPLACEMENT (CONT)

3. DISCONNECT ENGINE WIRING HARNESS (6) FROM TURBO BOOST SENSOR (7).
4. REMOVE TWO RETAINING BOLTS (8) AND TURBO BOOST SENSOR (7).
5. REMOVE AND DISCARD SEAL RING (9).
6. REMOVE FIVE LONG BOLTS (10) AND TWO SHORT BOLTS (11) FROM AIR INTAKE MANIFOLD (5).
7. IF NECESSARY, USE BRASS DRIFT AND TAP AIR INTAKE MANIFOLD (5) LIGHTLY TO LOOSEN FROM CYLINDER HEAD (12). REMOVE AIR INTAKE MANIFOLD AND THREE GASKETS (13). DISCARD GASKETS.
8. REMOVE AIR TEMPERATURE SENSOR (14) FROM AIR INTAKE MANIFOLD (5).

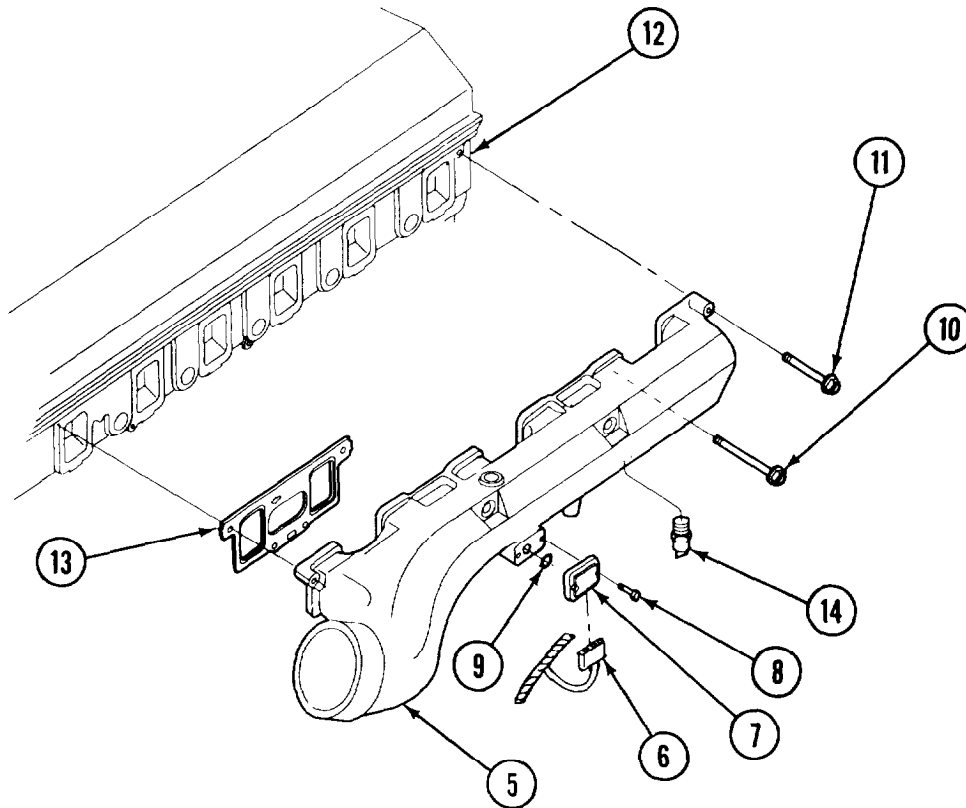

CLEANING

Use general cleaning methods to clean all parts (page 2-30).

INSPECTION

Inspect air intake manifold for cracks, particularly in mounting bolt boss areas. If cracked, discard air intake manifold.

INSTALLATION

1. COAT THREADS OF AIR TEMPERATURE SENSOR (1) WITH SEALING COMPOUND AND INSTALL AIR TEMPERATURE SENSOR IN AIR INTAKE MANIFOLD (2).

NOTE

Make sure that gaskets are positioned so that arrows of each gasket are facing front of engine.

Make sure all wires are clear of intake manifold connection points before installing manifold.

2. POSITION THREE NEW GASKETS (3) TO AIR INTAKE MANIFOLD (2) AND POSITION AIR INTAKE MANIFOLD TO CYLINDER HEAD (4).
3. INSTALL TWO SHORT BOLTS (5) HANDTIGHT IN AIR INTAKE MANIFOLD (2), ONE AT EACH END.
4. INSTALL FIVE LONG BOLTS (6) IN AIR INTAKE MANIFOLD (2).

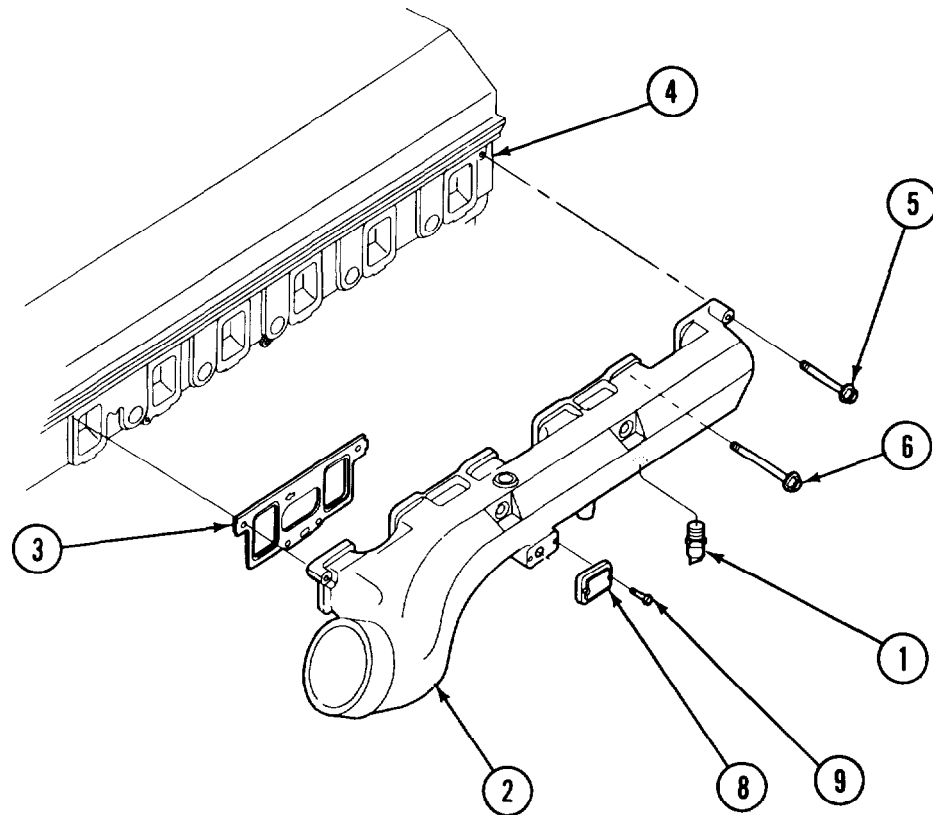

AIR INTAKE MANIFOLD REPLACEMENT (CONT)

5. TORQUE SEVEN BOLTS (5 AND 6) TO 43-54 LB-FT (58-73 N.m) IN SEQUENCE SHOWN.

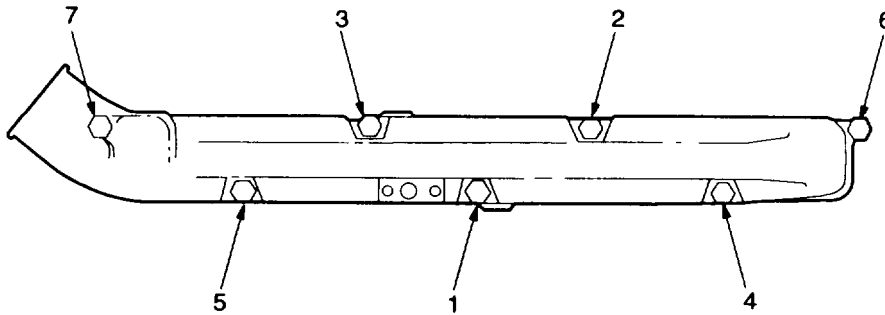

6. COAT NEW SEAL RING (7) WITH LUBRICATING OIL AND INSTALL SEAL RING IN AIR INTAKE MANIFOLD (2).
7. INSTALL TURBO BOOST SENSOR (8) AND TWO RETAINING BOLTS (9) IN AIR INTAKE MANIFOLD (2). TORQUE BOLTS TO 21-26 LB-IN. (2.4 - 2.9 N.m).
8. CONNECT ENGINE WIRING HARNESS (10) TO TURBO BOOST SENSOR (8).

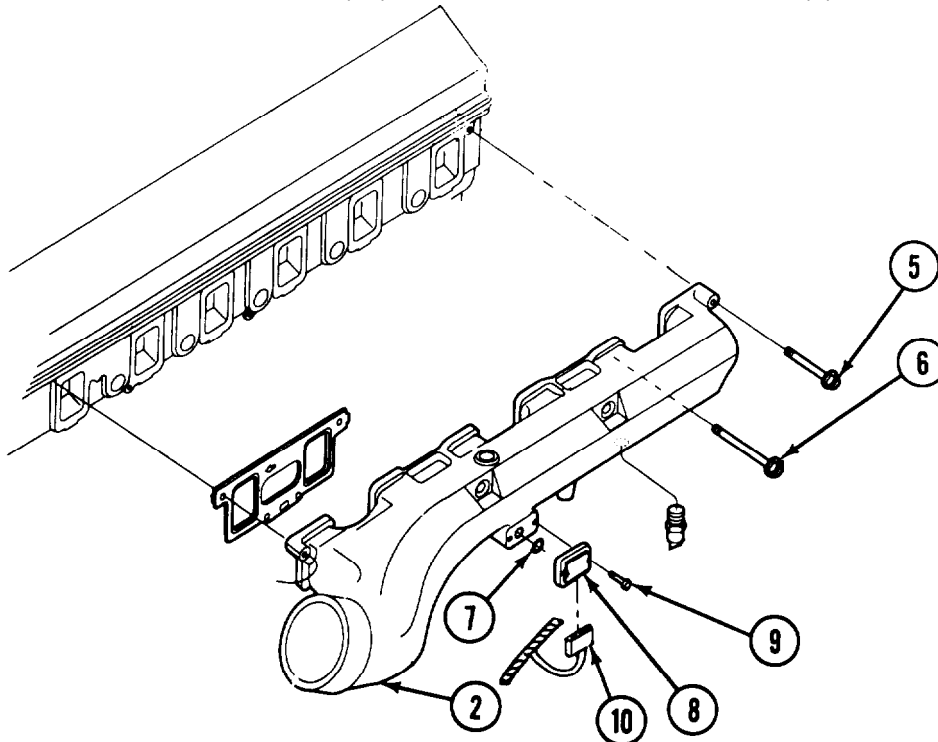

9. COAT THREADS OF REDUCER (11) WITH SEALING COMPOUND AND INSTALL REDUCER IN AIR INTAKE MANIFOLD (2).
10. COAT THREADS OF AIR SUPPLY CONNECTOR (12) WITH SEALING COMPOUND AND INSTALL AIR SUPPLY CONNECTOR IN REDUCER (11).
11. CONNECT AIR COMPRESSOR INLET HOSE (13) TO AIR SUPPLY CONNECTOR (11).
12. POSITION AND TIGHTEN HOSE CLAMP (14).

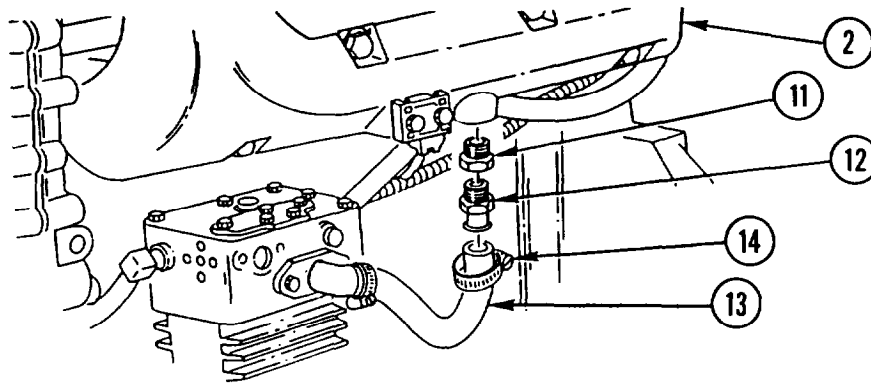

NOTE

Follow-on Maintenance:

Install air intake manifold to intercooler tube (TM 9-2320-363-20).
 Connect batteries (TM 9-2320-363-20).

EXHAUST MANIFOLD REPLACEMENT

This task covers: a. Removal b. Cleaning c. Inspection d. Installation

Applicable Configuration:

M915A2 and M916A1

Tools and Special Equipment:

Shop Equipment, SC 4910-95-CL-A31
 Tool Kit, SC 5180-90-CL-N05
 Guide, Stud (4), J36107

Materials/Parts:

Gasket (3) P/N 23511666

Equipment Description:

Reference	Condition Description
Page 3-101	Turbocharger Removed
Page 3-78	Breather Tube Removed

General Safety Instructions:

WARNING

Exhaust manifold weighs 60 lb (27 kg). Use extreme caution during removal or installation to prevent possible injury to personnel.

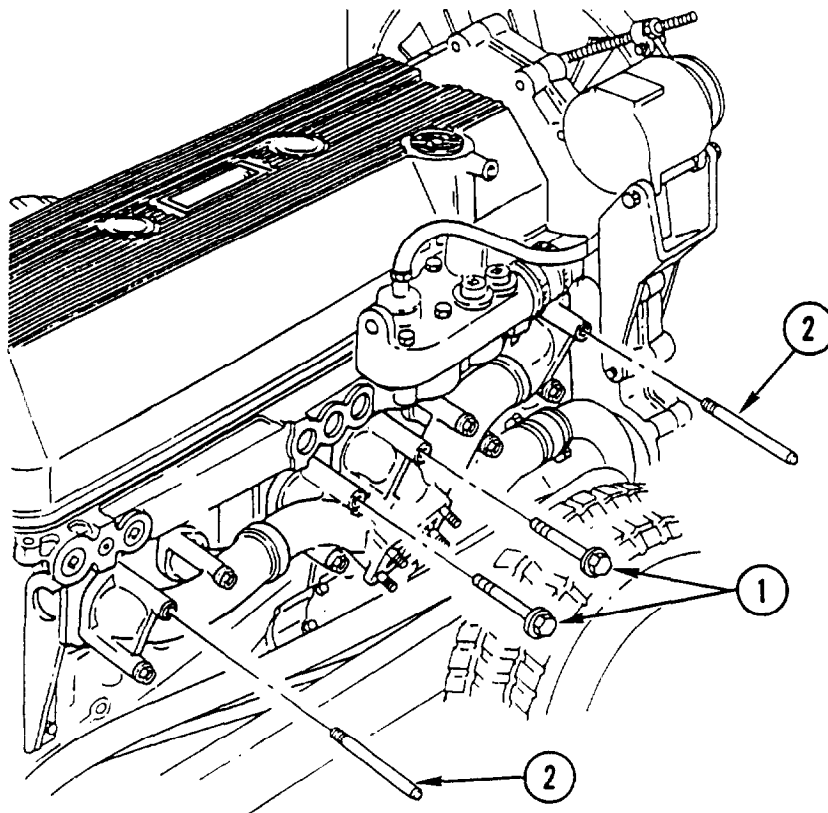

1. REMOVE FOUR BOLTS (1) AND INSTALL FOUR GUIDE STUDS (2)

EXHAUST MANIFOLD REPLACEMENT (CONT)

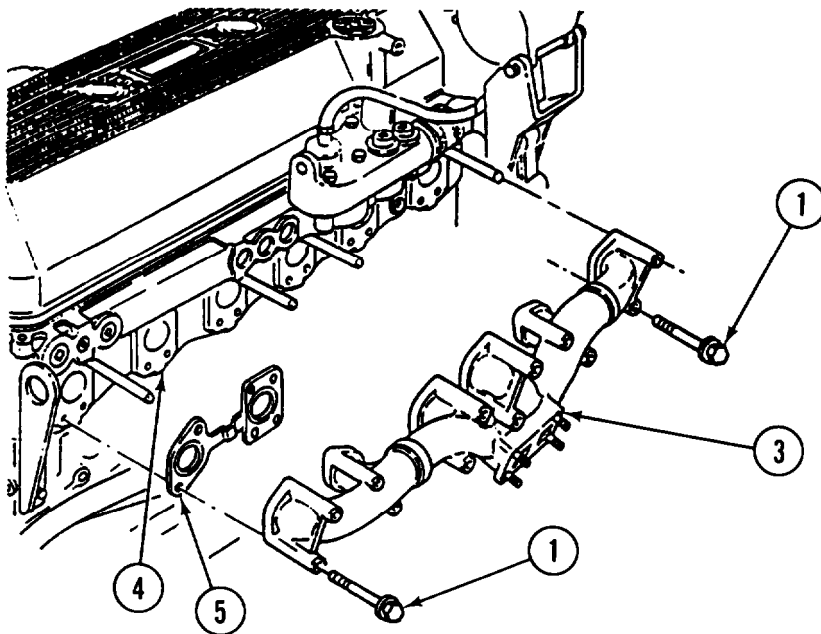

WARNING

Exhaust manifold weighs 60 lb (27 kg). Use extreme caution during removal to prevent possible injury to personnel.

2. REMOVE REMAINING EIGHT BOLTS (1) AND EXHAUST MANIFOLD (3) FROM CYLINDER HEAD (4).
3. REMOVE AND DISCARD EXHAUST MANIFOLD GASKETS (5).

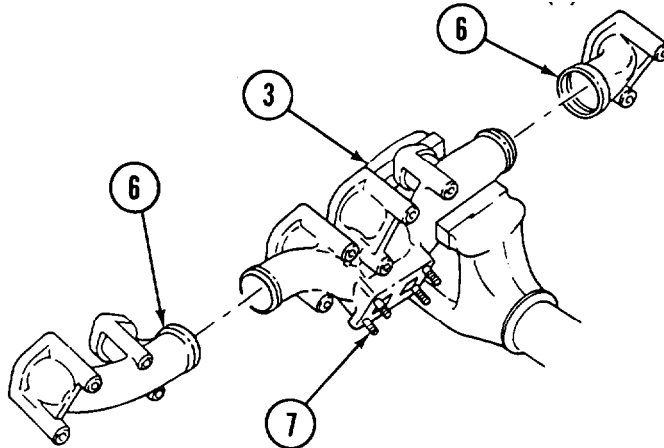

4. SECURE CENTER SECTION OF EXHAUST MANIFOLD (3) IN SOFT-JAWED VISE. USING BRASS DRIFT AND HAMMER ON CENTER SECTION SIDE OF FLANGES (6), DRIVE END SECTIONS OF EXHAUST MANIFOLD OFF.
5. IF DAMAGED, REMOVE AND DISCARD FOUR TURBOCHARGER MOUNTING STUDS (7).

CLEANING

Use general cleaning methods to clean all parts (page 2-30).

1. INSPECT EXHAUST MANIFOLD FOR CRACKS, PARTICULARLY IN MOUNTING BOLT BOSS AREAS. IF CRACKED, DISCARD EXHAUST MANIFOLD SECTION.
2. INSPECT ALL PARTS FOR WEAR OR DAMAGE.

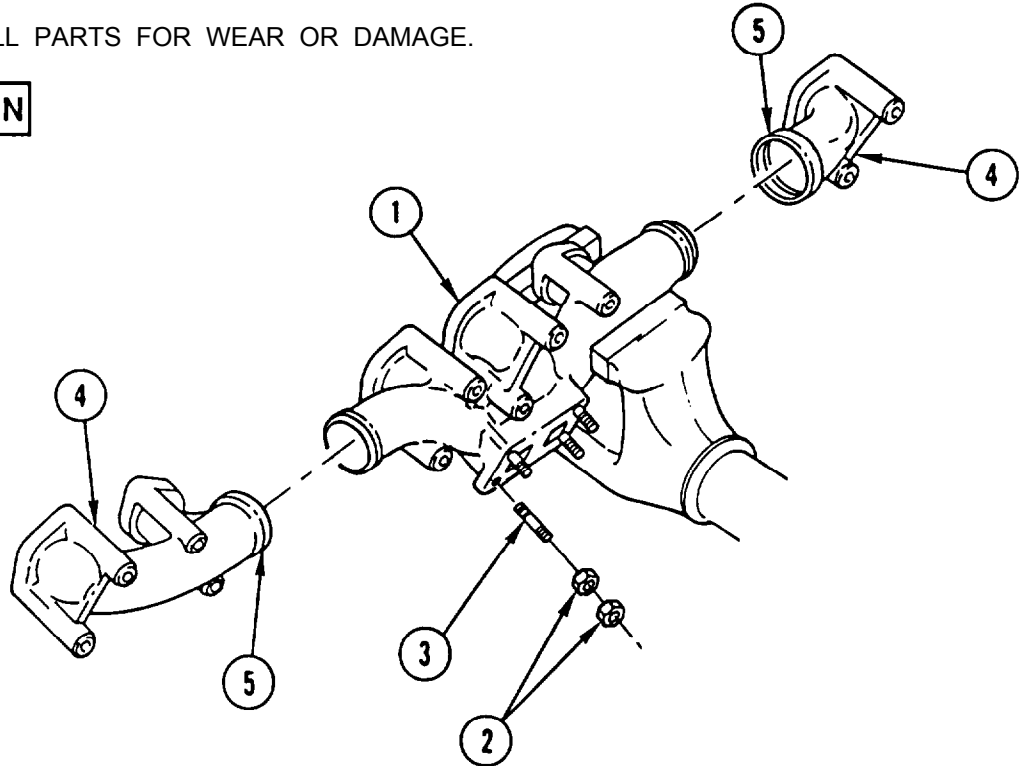
INSTALLATION**WARNING**

Exhaust manifold weighs 60 lb (27 kg). Use extreme caution during installation to prevent possible injury to personnel.

1. SECURE CENTER SECTION OF EXHAUST MANIFOLD (1) IN SOFT-JAWED VISE.

NOTE

Perform steps 2 and 3 if turbocharger mounting studs were removed.

2. INSTALL TWO NUTS (2) ON FOUR NEW TURBOCHARGER MOUNTING STUDS (3), USING ONE NUT AS JAM NUT.
3. THREAD NEW TURBOCHARGER MOUNTING STUDS (3) INTO EXHAUST MANIFOLD (1) UNTIL UNTHREADED PORTION OF STUD BOTTOMS AGAINST MOUNTING FLANGE. TIGHTEN STUDS TO 18-24 LB-FT (25-32 N.m). REMOVE TWO NUTS (2).
4. INSTALL END SECTIONS (4) ON CENTER SECTION OF EXHAUST MANIFOLD (1). POSITION AND SEAT END SECTIONS (4) BY TAPPING OUTBOARD SIDE OF FLANGE (5) WITH FIBER OR PLASTIC MALLET.

EXHAUST MANIFOLD REPLACEMENT (CONT)

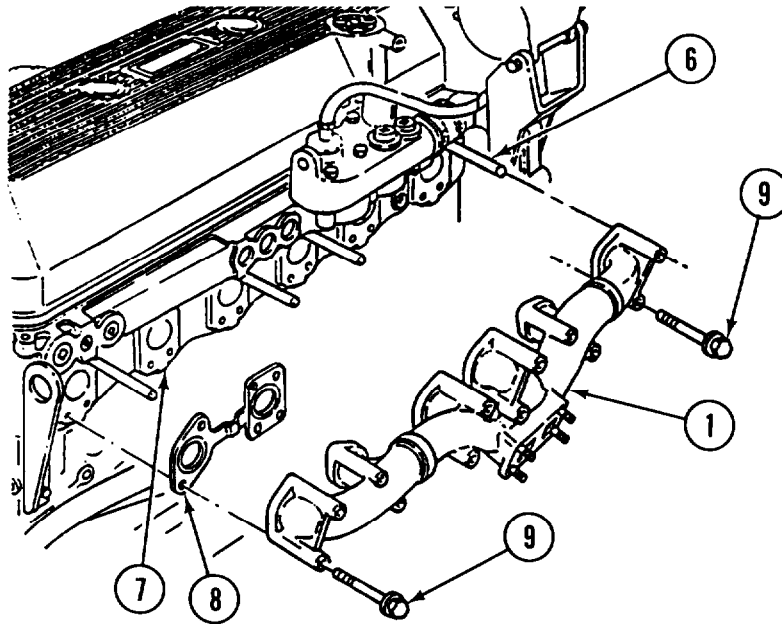

5. INSTALL FOUR GUIDE STUDS (6) IN CYLINDER HEAD (7) IN BOLT HOLES NO. 1, NO. 3, NO. 10, AND NO. 12.

NOTE

Exhaust manifold gaskets can be installed with bead facing in or out. Make sure guide studs and exhaust manifold gaskets are positioned correctly for exhaust manifold installation.

6. INSTALL THREE NEW EXHAUST MANIFOLD GASKETS (8) ON GUIDE STUDS (6).
7. INSTALL EXHAUST MANIFOLD (1).
8. INSTALL EIGHT BOLTS (9) IN MOUNTING HOLES.
9. REMOVE FOUR GUIDE STUDS (6) AND INSTALL REMAINING FOUR BOLTS (9).

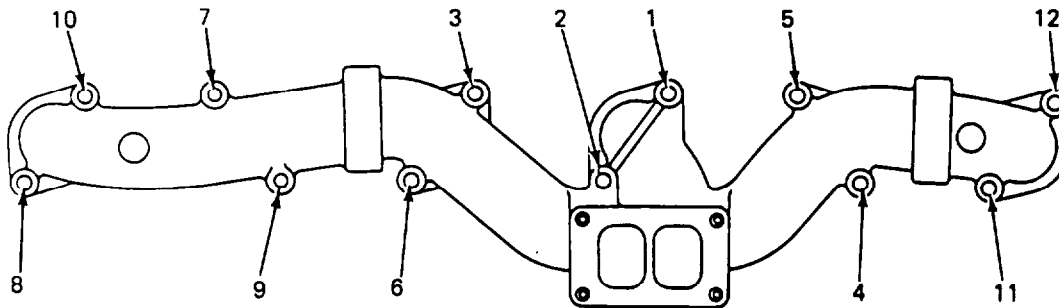

10. TIGHTEN BOLTS TO 43-54 LB-FT (58-73 N.m) IN SEQUENCE SHOWN.

NOTE

Follow-on Maintenance:

Install turbocharger (page 3-101).

Install breather tube (page 3-78).

EXHAUST MANIFOLD REPLACEMENT

This task covers: a. Removal b. Cleaning c. Inspection d. Installation

INITIAL SETUP

Applicable Configuration:

All except M915A2 and M916A1

Tools and Special Equipment:

Shop Equipment, SC 4910-95CL-A31
 Tool Kit, SC 5180-90-CL-N05

Materials/Parts:

Gasket (3) P/N 23511666

Equipment Condition:

Reference	Condition Description
Page 3-101	Turbocharger Removed
Page 3-78	Breather Tube Removed

General Safety Instructions:

WARNING

Exhaust manifold weighs 60 lb (27 kg). Use extreme caution during removal or installation to prevent possible injury to personnel.

EXHAUST MANIFOLD REPLACEMENT (CONT)

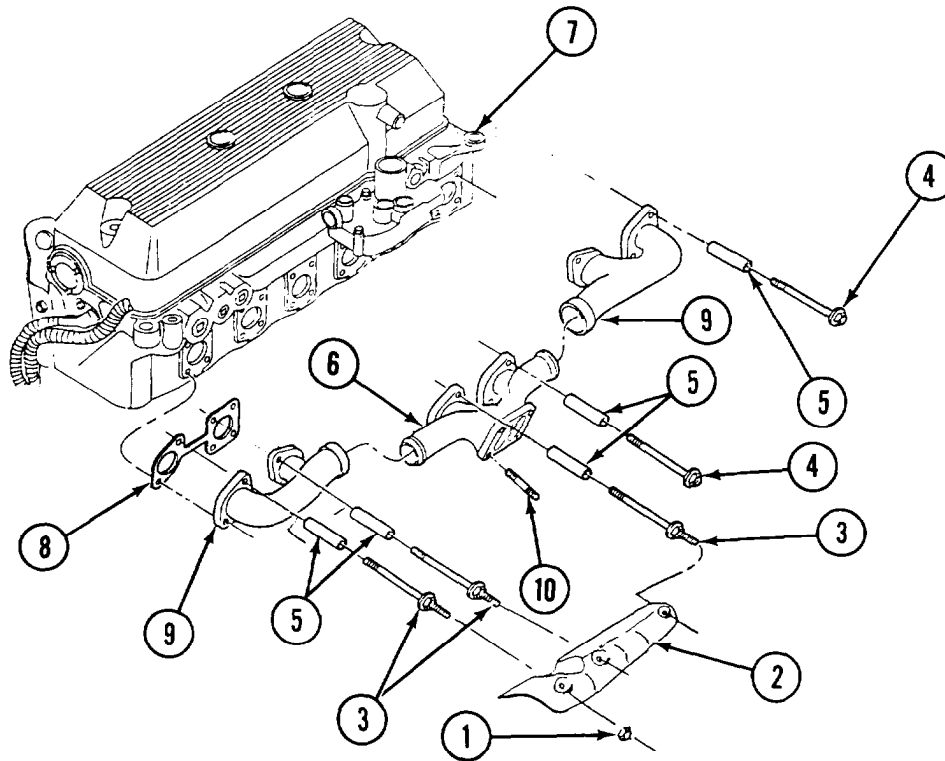

1. REMOVE THREE NUTS (1), HEAT SHIELD (2), THREE STUD BOLTS (3), TWO BOLTS (4), AND FIVE SPACERS (5) FROM EXHAUST MANIFOLD (6).

WARNING

Exhaust manifold weighs 60 lb (27 kg). Use extreme caution during removal or installation to prevent possible injury to personnel.

2. REMOVE REMAINING SEVEN BOLTS (4), SPACERS (5) AND EXHAUST MANIFOLD (6) FROM CYLINDER HEAD (7).

NOTE

Each of the three gaskets is in two pieces.

3. REMOVE AND DISCARD THREE GASKETS (8).
4. SECURE CENTER SECTION OF EXHAUST MANIFOLD (6) IN SOFT JAWED VISE. USING BRASS DRIFT, REMOVE EACH END SECTION (9) OF EXHAUST MANIFOLD.
5. IF DAMAGED, REMOVE AND DISCARD FOUR TURBOCHARGER MOUNTING STUDS (10).

CLEANING

Use general cleaning methods to clean all parts (page 2-30).

INSPECTION

1. INSPECT EXHAUST MANIFOLD FOR CRACKS, PARTICULARLY IN MOUNTING BOLT BOSS AREAS. IF CRACKED, DISCARD EXHAUST MANIFOLD SECTION.
2. INSPECT ALL PARTS FOR DAMAGE

INSTALLATION

1. SECURE CENTER SECTION OF EXHAUST MANIFOLD (1) IN SOFT JAWED VISE.

NOTE

Perform steps 2 and 3 if turbocharger mounting studs were removed.

2. INSTALL TWO NUTS (2) ON FOUR NEW TURBOCHARGER MOUNTING STUDS (3), USING ONE NUT AS JAM NUT.
3. THREAD NEW TURBOCHARGER MOUNTING STUDS (3) INTO EXHAUST MANIFOLD (1) UNTIL UNTHREADED PORTION OF STUD BOTTOMS AGAINST MOUNTING FLANGE. TORQUE STUDS TO 18-24 LB-FT (25-32 N.m). REMOVE TWO NUTS FROM EACH STUD.
4. INSTALL END SECTIONS (4) ON CENTER SECTION OF EXHAUST MANIFOLD (1). POSITION AND SEAT END SECTIONS BY TAPPING WITH FIBER OR PLASTIC MALLET.
5. INSTALL THREE NEW GASKETS (5), EXHAUST MANIFOLD (1), TWELVE SPACERS (6), NINE BOLTS (7), AND THREE STUD BOLTS (8) TO CYLINDER HEAD (9).

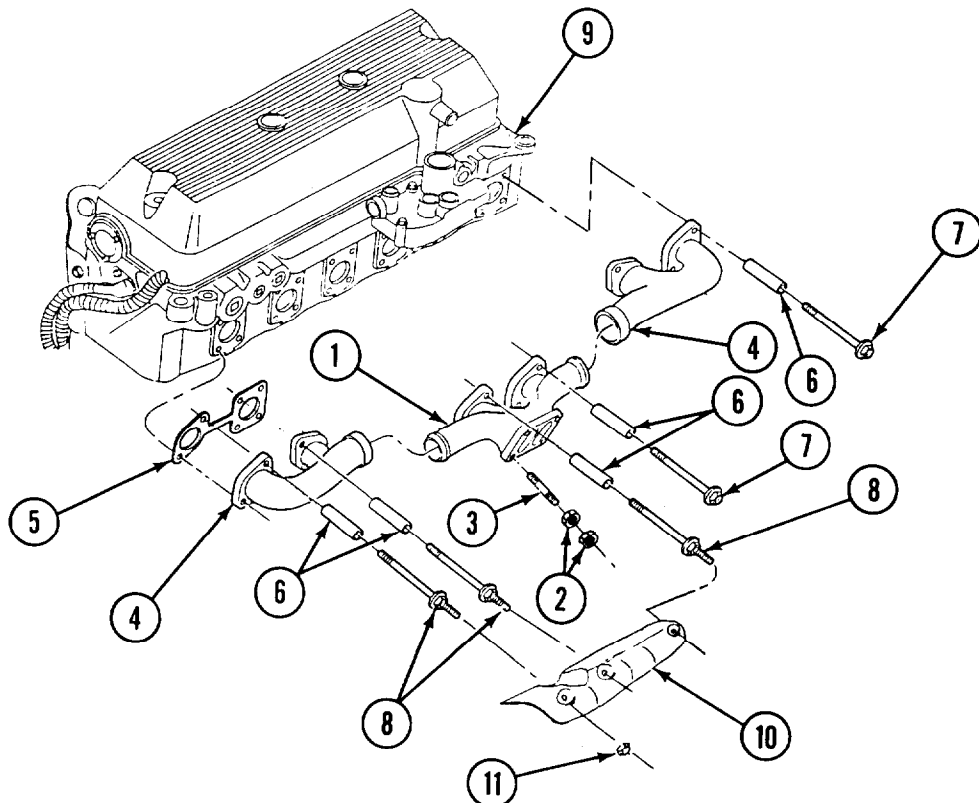

EXHAUST MANIFOLD REPLACEMENT (CONT)

6. TORQUE ALL BOLTS (7 AND 8) TO 43-54 LB-FT (58-73 N.m) IN SEQUENCE SHOWN.

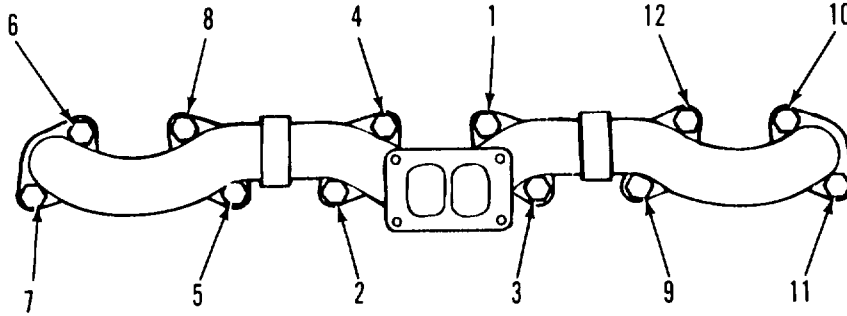

NOTE

Failure to cut the gaskets into two halves may result in leakage after installation

7. USING TIN SNIPS, CUT EACH OF THREE GASKETS (5) INTO TWO HALVES AS SHOWN

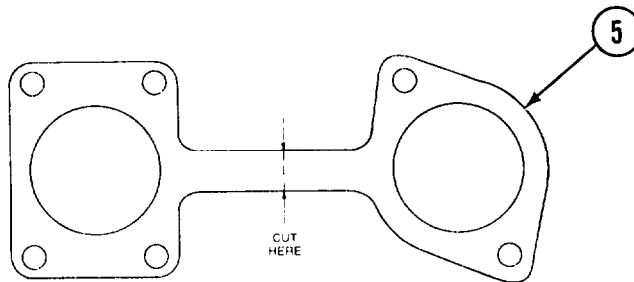

8. INSTALL HEAT SHIELD (10) WITH THREE NUTS (11).

NOTE

Follow-on Maintenance:

- Install turbocharger (page 3-101).
- Install breather tube (page 3-78).

ROCKERCOVER REPLACEMENT

This task covers: a. Removal b. Cleaning c. Inspection d. Installation

INITIAL SETUP

Tools and Special Equipment:

Shop Equipment, SC 4910-95-CL-A31
 Tool Kit, SC 5180-90-CL-N05

Materials/Parts:

Gasket P/N 8929863
 Sealant, RTV Appendix B, Item 52
 Solvent, Drycleaning Appendix B, item 54

References:

TM 9-2320-363-20

Equipment Condition:

Reference

TM 9-2320-363-20

Condition Description

Air Cleaner, Pre-Cleaner,
 and Duct Assembly
 Removed

TM 9-2320-363-20

Thermostat to Radiator
 Coolant Tube Removed

Equipment Condition (Cont):

Reference

TM 9-2320-363-20

Condition Description

Diagonal Radiator Support
 Rod Removed

General Safety Instructions:

WARNING

Adhesives, solvents, and sealing compounds can burn easily, can give off harmful vapors, and are harmful to skin and clothing. To avoid injury or death, keep away from open fire and use in well-ventilated area. If adhesive, solvent, or sealing compound gets on skin or clothing, wash immediately with soap and water.

ROCKER COVER REPLACEMENT (CONT)

REMOVAL

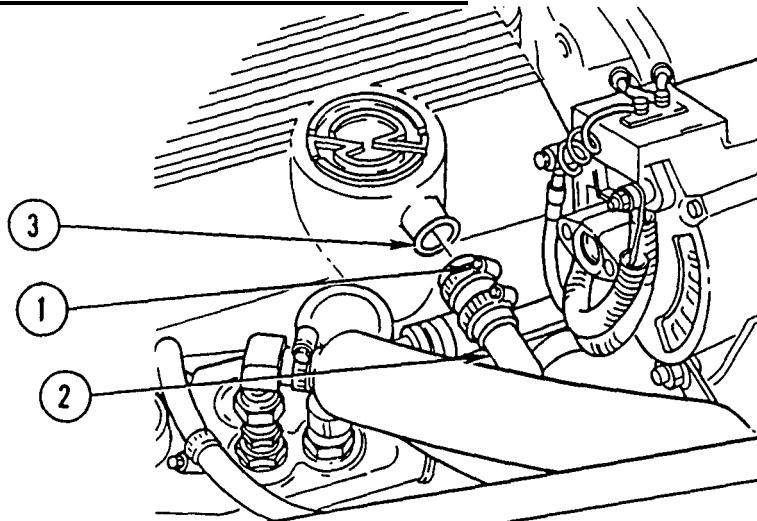

1. LOOSEN HOSE CLAMP (1) AND DISCONNECT CRANKCASE BREATHER TUBE(2) FROM ROCKER COVER NECK (3).
2. REMOVE TWO ROCKER COVER PLUGS (4), FOUR BOLTS (5), FOUR WASHERS (6), AND FOUR ISOLATORS(7).

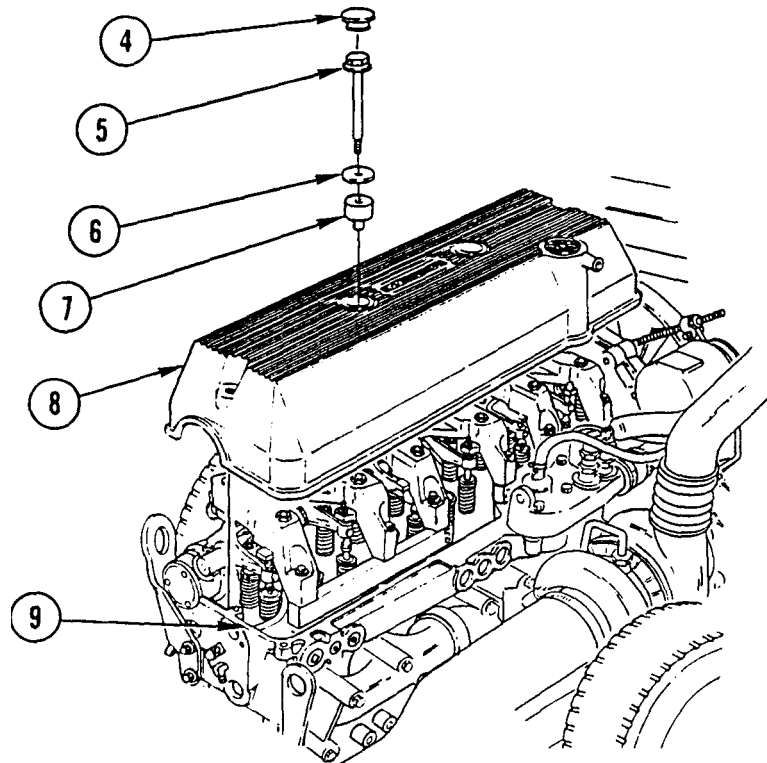

CAUTION

Handle rocker cover carefully, Dropping or bumping may cause unreparable damage.

3. REMOVE ROCKER COVER (8) FROM CYLINDER HEAD (9).

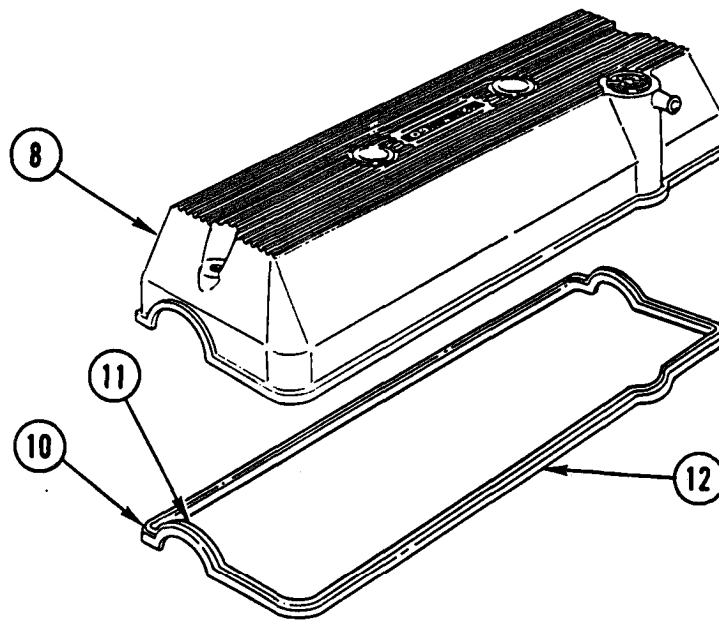

CAUTION
Do not pull rocker cover gasket to remove to prevent damage to equipment.

4. FREE GASKET SADDLE CORNERS (10) AND SADDLE ARCH AREAS (11). LIFT ROCKER COVER GASKET (12) STRAIGHT OUT OF ROCKER COVER (8) GROOVE TO PREVENT TEARING OR STRETCHING GASKET (12). DISCARD GASKET IF DAMAGED OR STRETCHED.

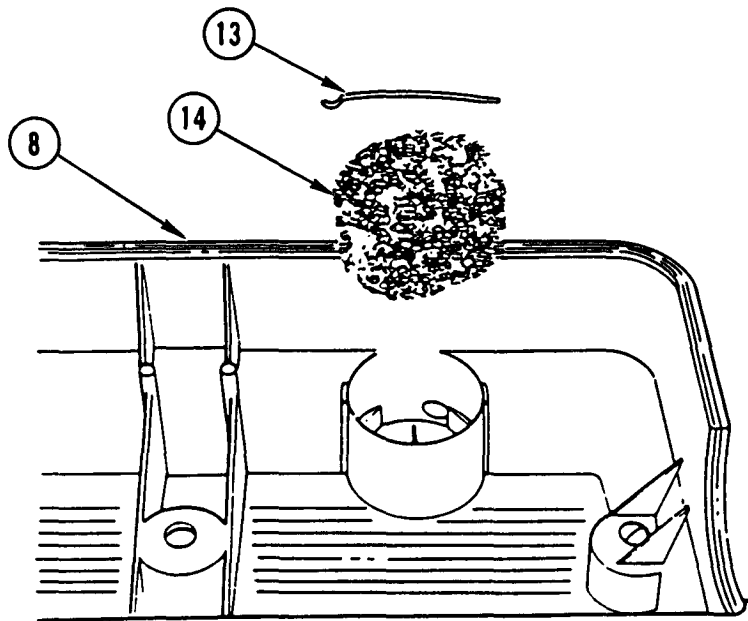

5. INVERT ROCKER COVER (8) ON BENCH. PRESS AND SLIDE STRAIGHT END OF BREATHER ELEMENT RETAINING CLIP (13) UNTIL CLIP (13) DISENGAGES FROM ROCKER COVER (8), LIFT CLIP (13) UPWARD TO DISENGAGE CURVED END.
6. REMOVE BREATHER ELEMENT (MESH) (14) FROM ROCKER COVER (8).

ROCKER COVER REPLACEMENT (CONT)

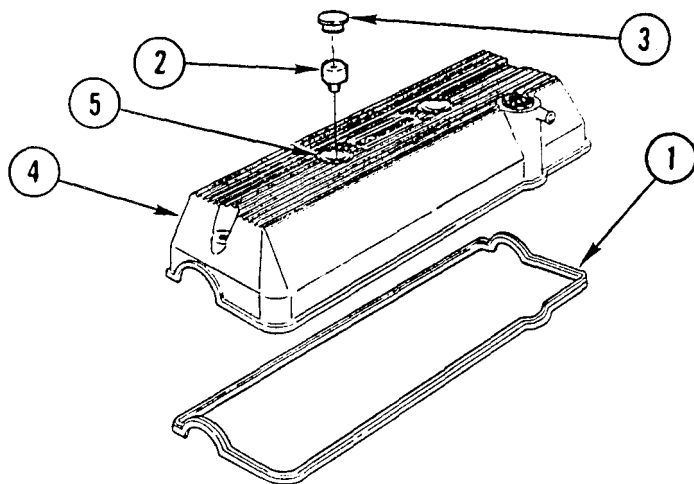

1. CLEAN ROCKER COVER GASKET (1), FOUR ISOLATORS (2), AND TWO ROCKER COVER PLUGS (3) WITH MILD SOAP AND WATER AND DRY WITH COMPRESSED AIR. DISCARD IF DAMAGED.
2. CLEAN ALL OLD RTV SEALANT FROM ROCKER COVER GROOVES. CLEAN ALL DIRT AND FOREIGN MATTER FROM ROCKER COVER (4) AND ROCKER COVER HOLDDOWN BOLT RECESSES (5).

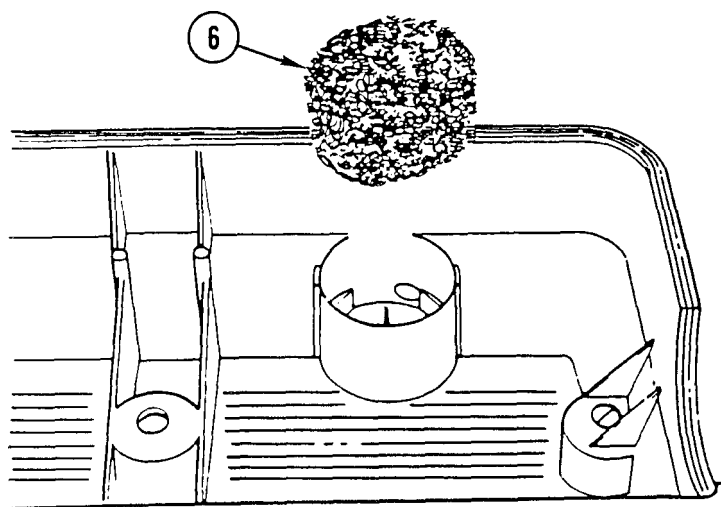

WARNING

Adhesives, solvents, and sealing compounds can burn easily, can give off harmful vapors, and are harmful to skin and clothing. To avoid injury or death, keep away from open fire and use in well-ventilated area. If adhesive, solvent, or sealing compound gets on skin or clothing, wash immediately with soap and water.

3. CLEAN BREATHER ELEMENT (MESH) (6) WITH SOLVENT AND DRY WITH COMPRESSED AIR.
4. REMOVE OLD RTV SEALANT FROM CORNERS OF CYLINDER HEAD LOCATED AT FRONT AND REAR CAM CAP AREA.

INSPECTION

Inspect all park for wear or damage.

INSTALLATION

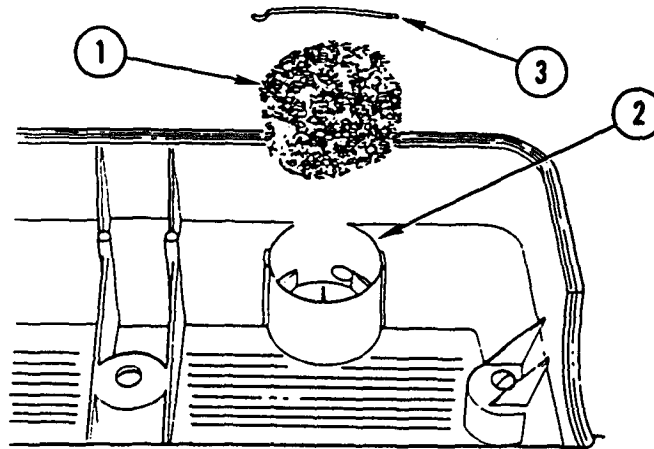

1. PRESS BREATHER ELEMENT (MESH) (1) INTO BREATHER POCKET (2).
2. INSERT CURVED END OF BREATHER ELEMENT RETAINING CLIP (3) INTO ONE BREATHER POCKET (2) HOLE. PRESS AND SLIDE STRAIGHT END OF CLIP (3) INTO OPPOSITE BREATHER POCKET (2) HOLE.

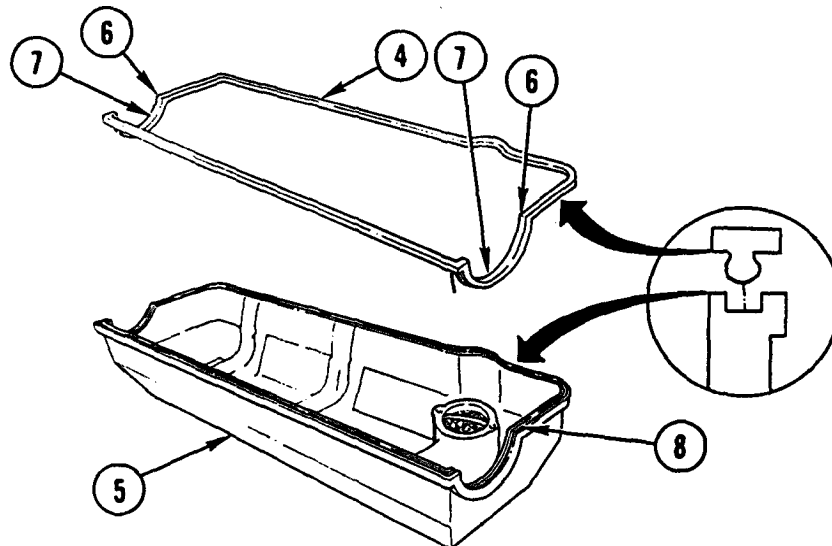

3. POSITION ROCKER COVER GASKET (4) IN ROCKER COVER (5).
4. INSTALL ROCKER COVER GASKET (4) BEGINNING AT CORNERS (6) OF SADDLE ARCH (7) ON EACH END OF ROCKER COVER (5). WORK BACK INTO SADDLE ARCH (7) EQUALLY FROM EACH CORNER (6) PUSHING GASKET (4) FIRMLY INTO ROCKER COVER GROOVE (8).

NOTE

Make sure rocker cover gasket is firmly seated in rocker cover groove.

5. BEGINNING AT CENTER OF ROCKER COVER (5), INSTALL LONG RUNS OF ROCKER COVER GASKET (4) TOWARD CORNERS (6) OF SADDLE ARCHES (7) AND CONTINUE UNTIL GASKET (4) INSTALLATION IS COMPLETED.

ROCKER COVER REPLACEMENT (CONT)

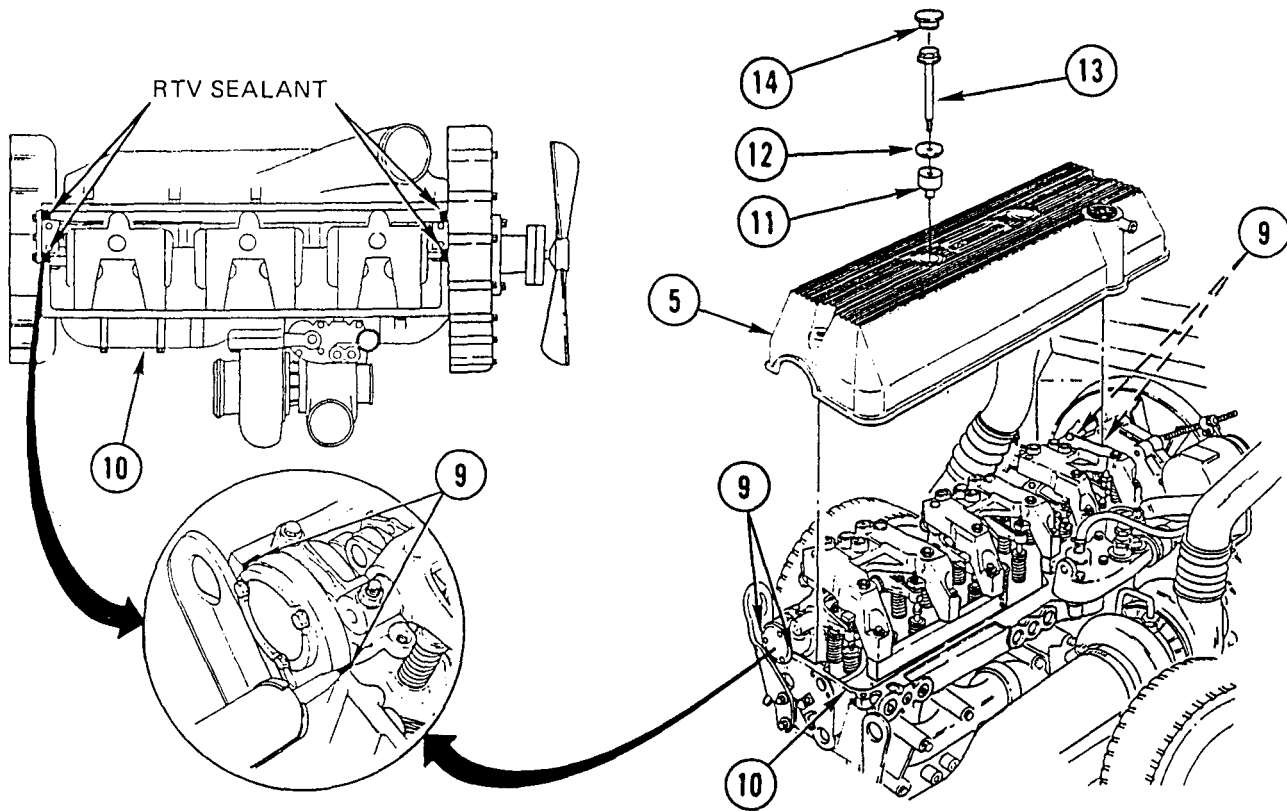

WARNING

Adhesives, solvents, and sealing compounds can burn easily, can give off harmful vapors, and are harmful to skin and clothing. To avoid injury or death, keep away from open fire and use in well-ventilated area. If adhesive, solvent, or sealing compound gets on skin or clothing, wash immediately with soap and water.

6. APPLY SMALL FILLET OF RTV SEALANT IN FRONT AND REAR CORNERS (9) OF CYLINDER HEAD (10) WHERE FRONT AND REAR CAM CAPS ARE LOCATED ON CYLINDER HEAD.

CAUTION

Handle rocker cover carefully, Dropping or bumping may cause unreparable damage.

7. POSITION ROCKER COVER (5) ON CYLINDER HEAD (10).
8. INSTALL FOUR ISOLATORS (11), FOUR WASHERS (12), AND FOUR BOLTS (13) THRU HOLES IN ROCKER COVER (5).

9. STARTING WITH CENTER BOLTS AND WORKING TO OUTER BOLTS, TIGHTEN FOUR BOLTS (13) TO 15-18 LB-FT (20-25 N.m).
10. PRESS TWO ROCKER COVER PLUGS (14) INTO ROCKER COVER (5) WITH HEEL OF HAND UNTIL PLUGS (14) ARE FULLY SEATED.

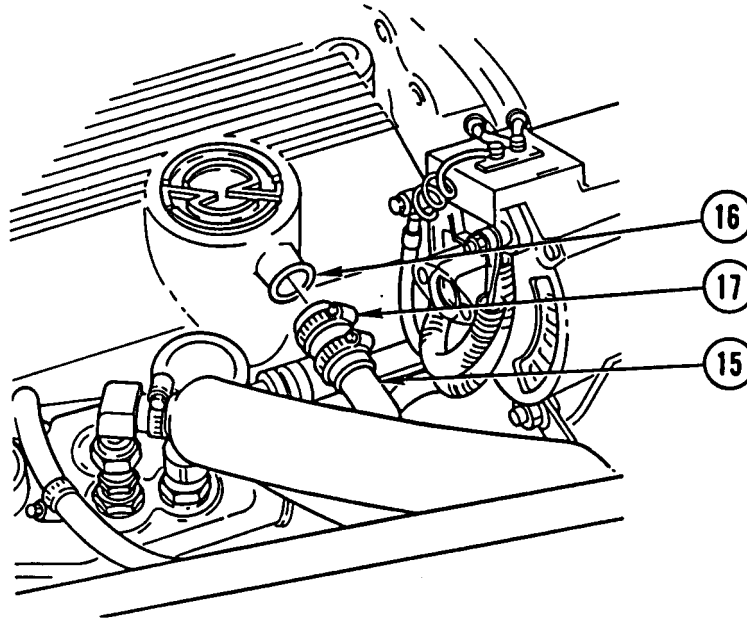

11. INSTALL CRANKCASE BREATHER TUBE (15) OVER ROCKER COVER NECK (16) AND SECURE WITH HOSE CLAMP (17).

NOTE

Follow-on Maintenance:

- Install air cleaner, pre-cleaner, and duct assembly (TM 9-2320-363-20).
- Install thermostat to radiator coolant tube (TM 9-2320-363-20).
- Install diagonal radiator support rod (TM 9-2320-363-20).

BREATHER TUBE REPLACEMENT

This task covers: a. Removal b. Cleaning c. Inspection d. Installation

INITIAL SETUP

Tools and Special Equipment:

Tool Kit, SC 5180-90-CL-N05

REMOVAL

1. LOOSEN HOSE CLAMP (1) AND DISCONNECT HOSE (2) FROM ROCKER COVER (3).
2. REMOVE TWO BOLTS (4) AND SPACER (5) FROM ENGINE BLOCK (6).
3. REMOVE BREATHER TUBE (7) AND TWO CLAMPS (8).
4. LOOSEN HOSE CLAMP (9) AND REMOVE HOSE (2) FROM BREATHER TUBE (7).

CLEANING

Use general cleaning methods to clean all parts (page 2-30).

INSPECTION

Inspect all parts for wear or damage.

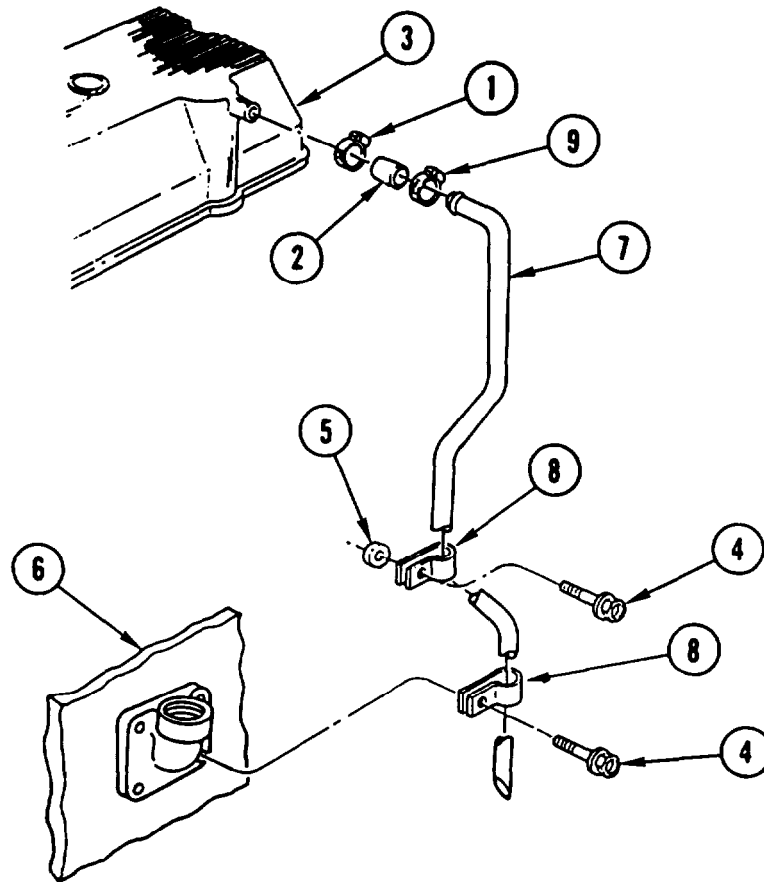

INSTALLATION

1. INSTALL HOSE (2) ON BREATHER TUBE (7) AND TIGHTEN HOSE CLAMP (9).
2. INSTALL BREATHER TUBE (7) AND TWO CLAMPS (8).
3. INSTALL SPACER (5) AND TWO BOLTS (4) ON ENGINE BLOCK (6).
4. CONNECT HOSE (2) TO ROCKER COVER (3) AND TIGHTEN HOSE CLAMP (1).

CYLINDER HEAD REPLACEMENT

This task covers: a. Removal b. Cleaning c. Inspection d. Installation

INITIAL SETUP

Tools and Special Equipment:

Shop Equipment, SC 4910-95-CL-A31
 Tool Kit, SC 5180-90-CL-N05
 Lifter, J35641
 Gear Pilot, J35906
 Retaining Tool, J35652

Materials/Parts:

Gasket P/N 23506120
 International
 Compound No. 2 Appendix B, Item 29

References:

TM 9-2320-363-20

Equipment Condition:

Reference	Condition Description
Page 3-67 or 3-70.1	Exhaust Manifold Removed
TM 9-2320-363-20	Thermostat and Thermostat Housing Cover Removed
Page 3-61 or 3-66.1	Air Intake Manifold Removed
TM 9-2320-363-20	Air Compressor Cooling Lines Disconnected

Equipment Description (Cont):

Reference	Condition Description
TM 9-2320-363-20	Alternator Removed
Page 3-162	Camshaft and Bearings Removed
Page 3-108	Injector Removed
Page 4-2	Injector Wiring Harness Removed
TM 9-2320-363-20	Water Level Sensor Removed
TM 9-2320-363-20	Transmission Tunnel Access Cover Removed

General Safety Instructions:

WARNING

- Cylinder head weighs 421 lb (191 kg). Use suitable lifting device to lift and support cylinder head. Failure to do so could result in injury to personnel.
- Make sure lifting device is securely fastened and weight being lifted does not exceed capacity of lifting device. Failure to do so may cause personal injury.

REMOVAL

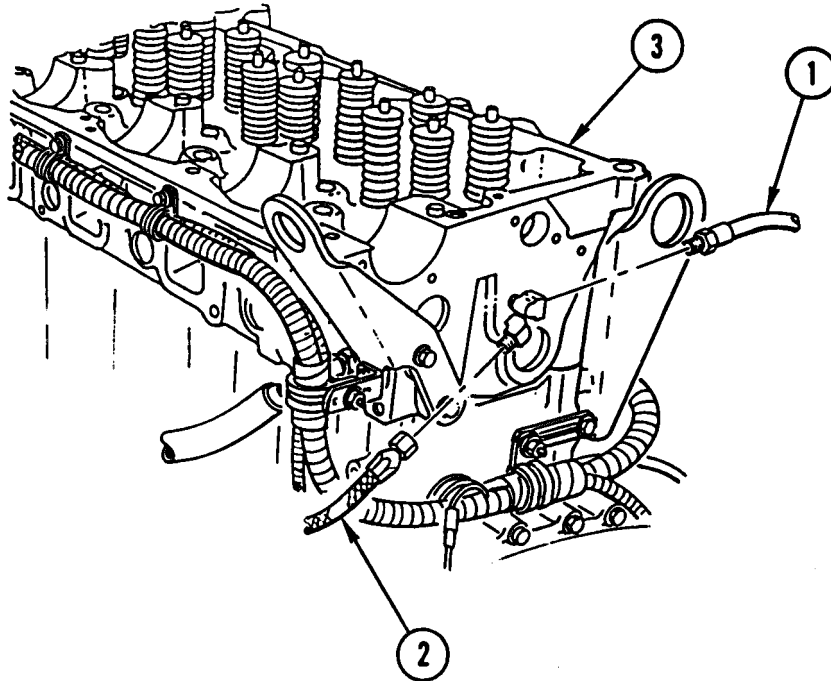

1. DISCONNECT TWO FUEL LINES (1 AND 2) FROM CYLINDER HEAD (3).

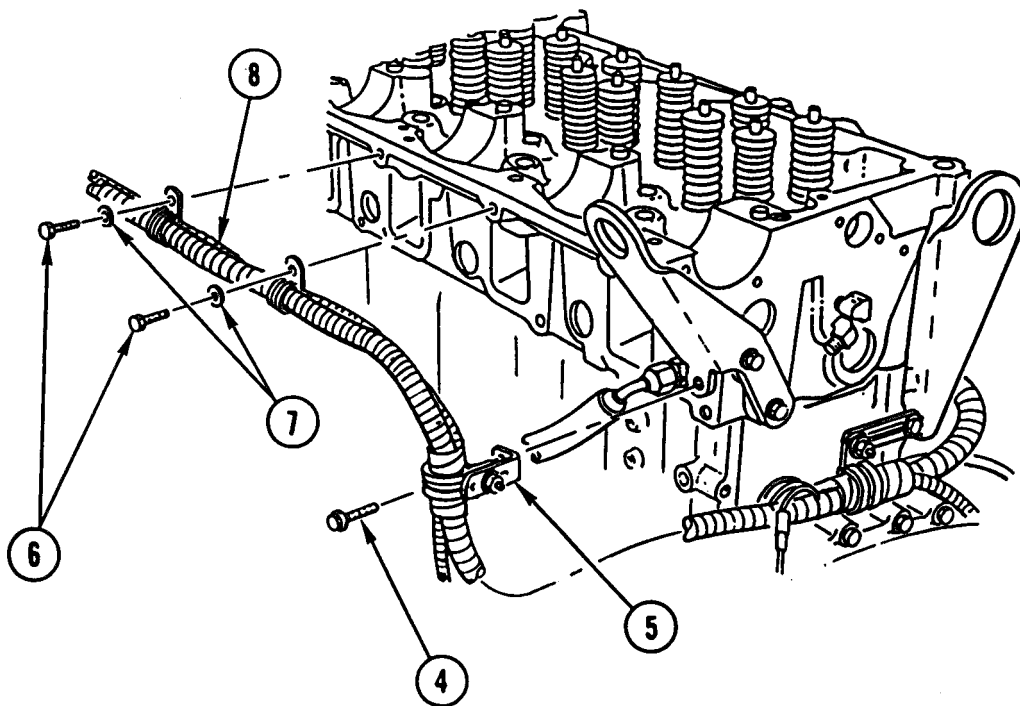

2. REMOVE BOLT (4) AND SET BRACKET (5) ASIDE.
3. REMOVE TWO BOLTS (6) AND TWO WASHERS (7) AND SET WIRING HARNESS (8) ASIDE.

CYLINDER HEAD REPLACEMENT (CONT)

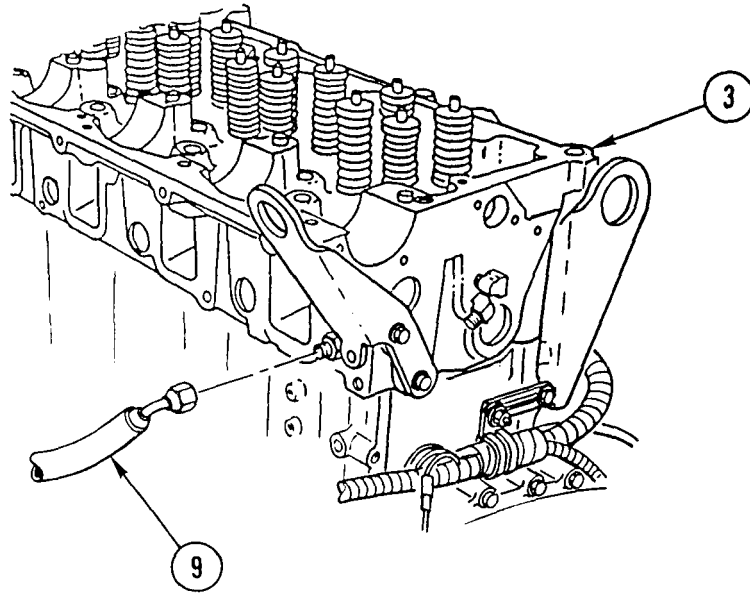

4. DISCONNECT AIR COMPRESSOR HOSE (9) FROM CYLINDER HEAD (3).

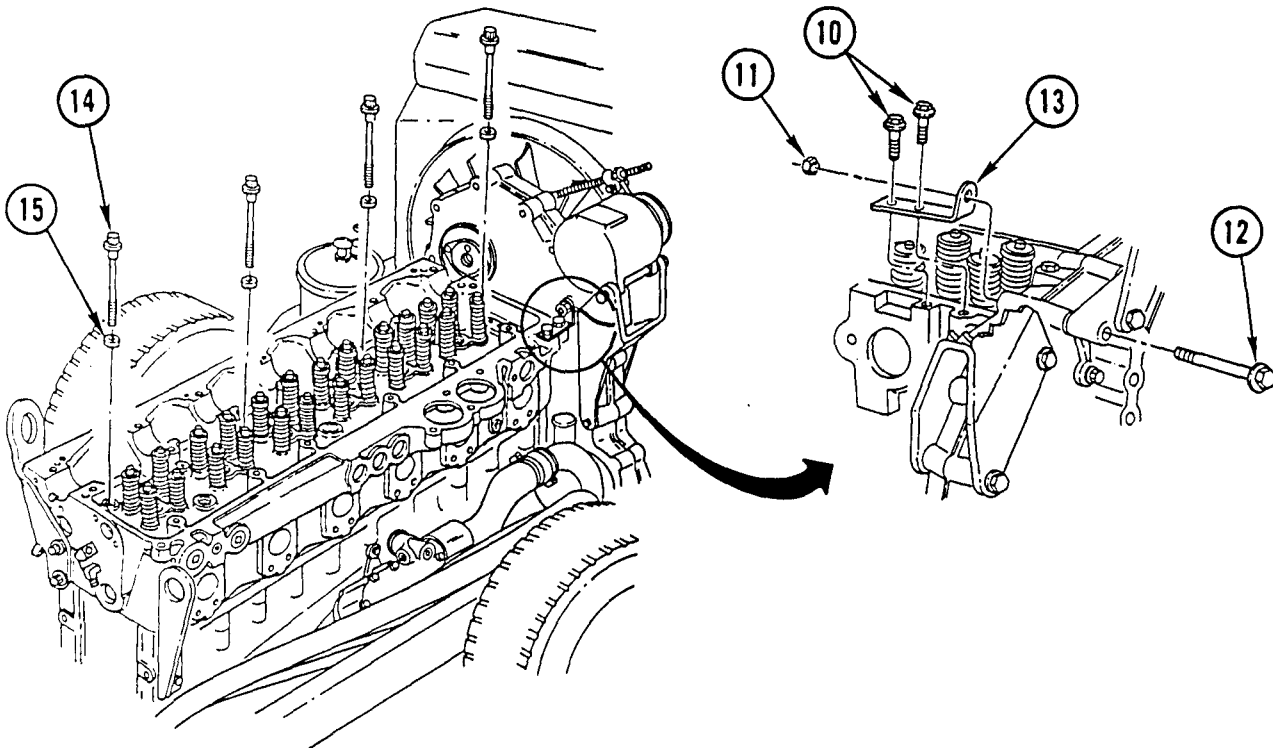

5. REMOVE TWO BOLTS (10), NUT (11), BOLT (12), AND BRACKET (13).
6. REMOVE 38 CYLINDER HEAD BOLTS (14) AND 38 WASHERS (15).

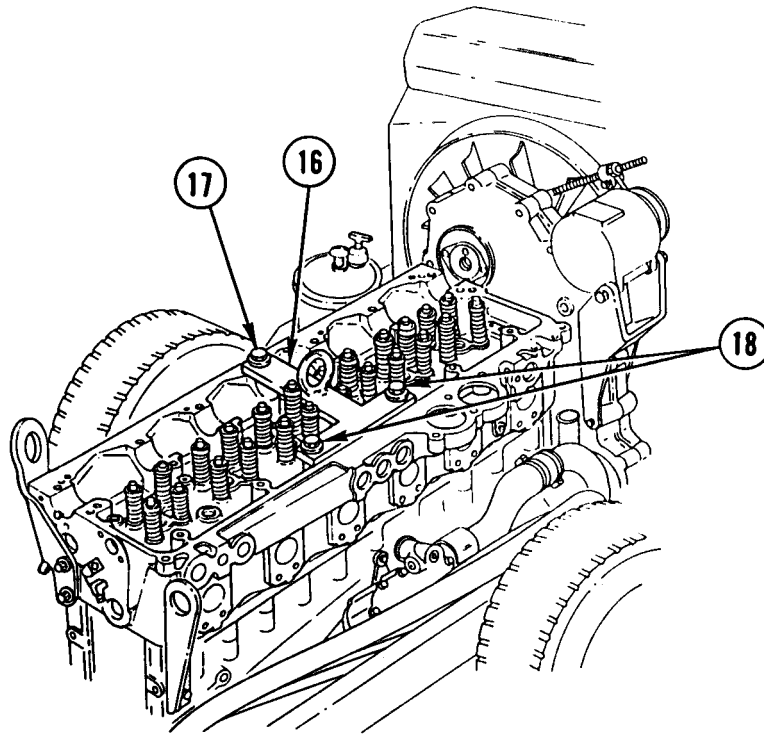

7. INSTALL LIFTER (16) BETWEEN FUEL INJECTOR HOLES NO. 3 AND NO. 4. INSTALL BOLT (17) USING BOLT HOLE FOR CENTER CAM CAP BOLT. INSTALL TWO BOLTS (18) USING TWO TAPPED HOLES FOR ENGINE RETARDER ASSEMBLY.

CYLINDER HEAD REPLACEMENT (CONT)

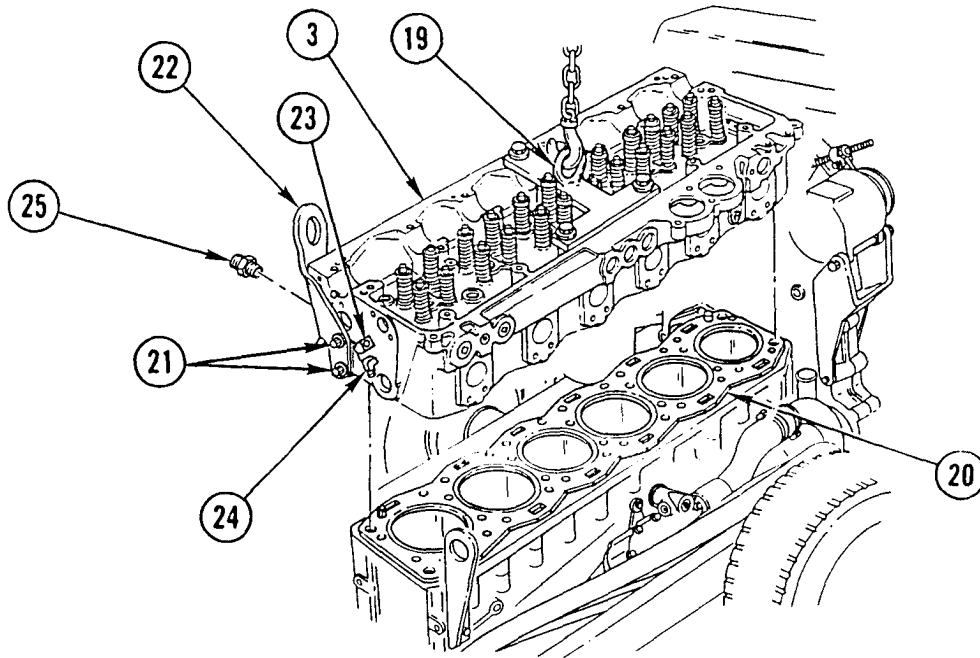

WARNING

- Cylinder head weighs 421 lb (191 kg). Use suitable lifting device to lift and support cylinder head. Failure to do so could result in injury to personnel.
- Make sure lifting device is securely fastened and weight being lifted does not exceed capacity of lifting device. Failure to do so may cause personal injury.

8. ATTACH SUITABLE LIFTING DEVICE TO LIFTER EYE (19) AND REMOVE CYLINDER HEAD (3).
9. REMOVE AND DISCARD CYLINDER HEAD GASKET (20).
10. REMOVE THREE BOLTS (21) AND LEFT REAR LIFTER BRACKET (22).

CAUTION

Tag elbows prior to removal to aid in installation. Failure to do so could result in damage to equipment.

11. REMOVE TWO ELBOWS (23 AND 24) FROM CYLINDER HEAD (3).
12. REMOVE AIR COMPRESSOR FITTING (25) FROM CYLINDER HEAD (3).

CLEANING

Use general cleaning methods to clean all parts (page 2-30).

INSPECTION

1. MAKE SURE PISTON DOMES, CYLINDER HEAD, CYLINDER BLOCK DECK SURFACES, AND INJECTOR TUBES ARE CLEAN AND FREE OF FOREIGN MATTER.
2. INSPECT CYLINDER BLOCK BOLT HOLES AND BLOCK-TO-HEAD GASKET MATING SURFACES FOR OIL, WATER, OR DIRT. CLEAN AS NECESSARY.

INSTALLATION

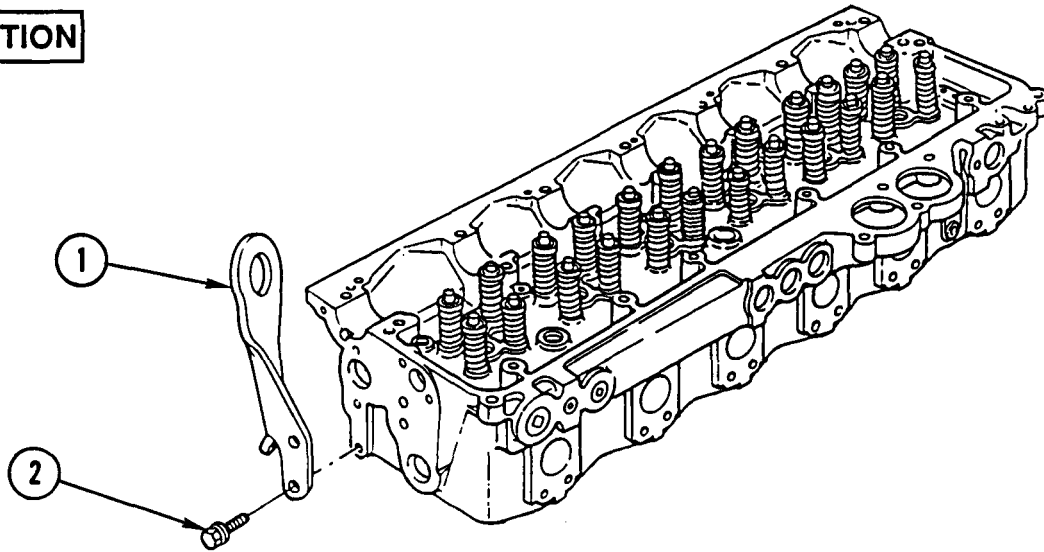

1. INSTALL LEFT REAR LIFTER BRACKET (1) AND THREE BOLTS (2). TIGHTEN BOLTS TO 75-93 LB-FT (101-126 N.m).

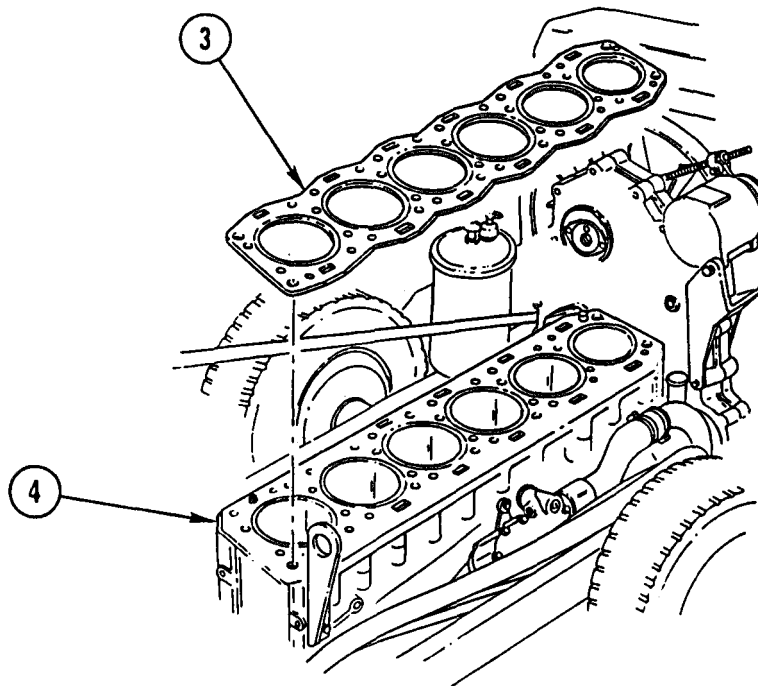

2. INSTALL NEW CYLINDER HEAD GASKET (3) ON CYLINDER BLOCK (4).

CYLINDER HEAD REPLACEMENT (CONT)

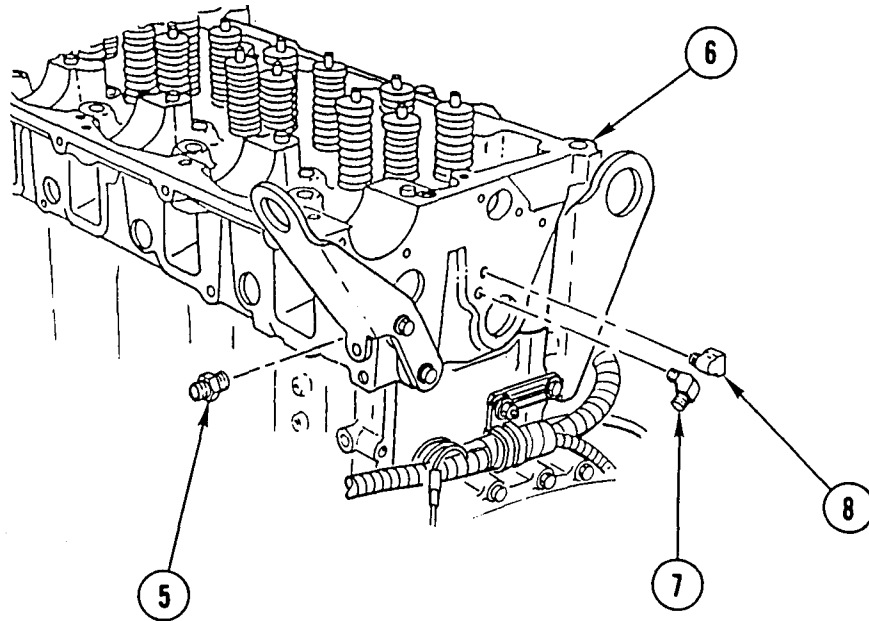

3. INSTALL AIR COMPRESSOR FITTING (5) IN CYLINDER HEAD (6).
4. INSTALL TWO ELBOWS (7 AND 8) IN CYLINDER HEAD (6).

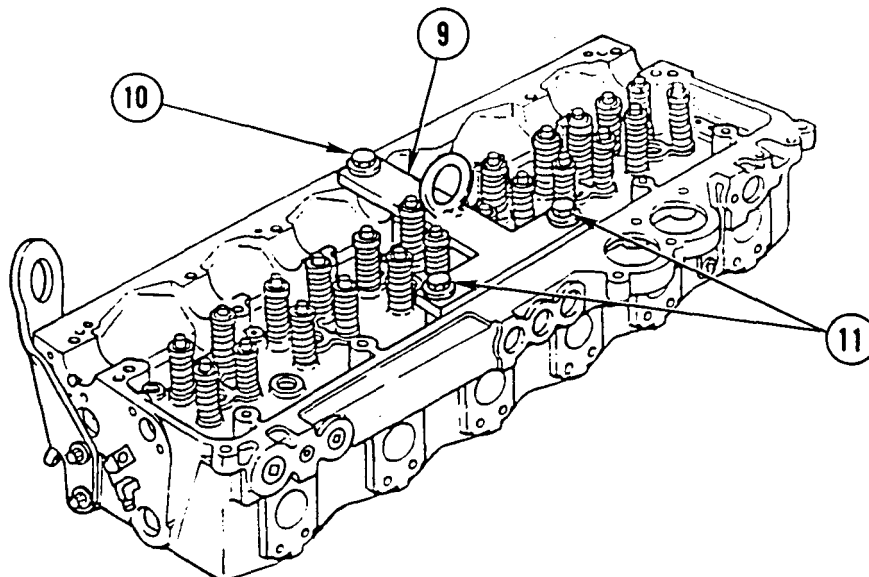

5. INSTALL LIFTER (9) BETWEEN FUEL INJECTORS NO. 3 AND NO. 4. INSTALL BOLT (10) USING BOLT HOLE FOR CENTER CAM CAP BOLT. INSTALL TWO BOLTS (11) USING TWO TAPPED HOLES FOR ENGINE RETARDER ASSEMBLY.

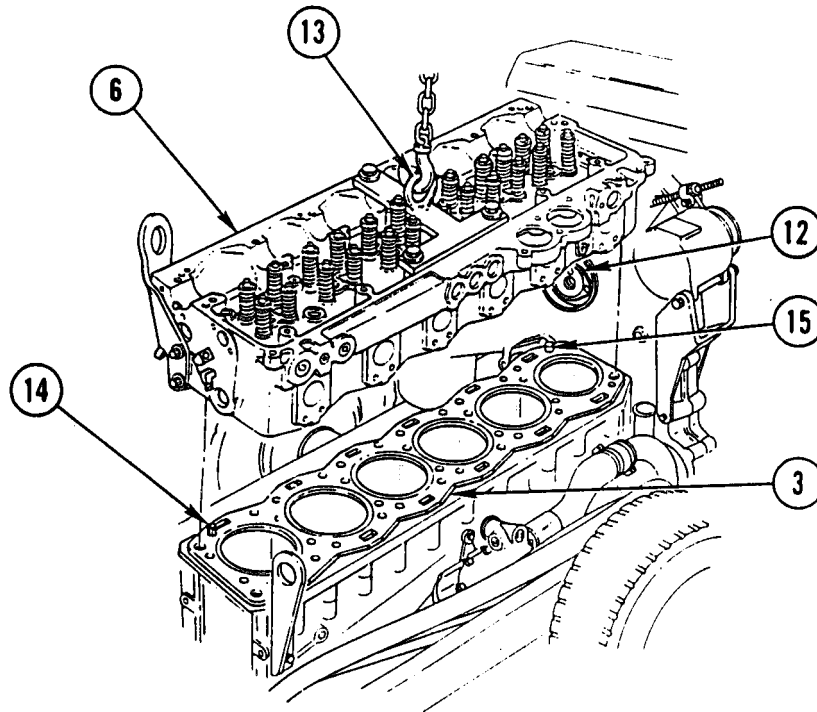

WARNING

- Cylinder head weighs 421 lb (191 kg). Use suitable lifting device to lift and support cylinder head. Failure to do so could result in injury to personnel.
- Make sure lifting device is securely fastened and weight being lifted does not exceed capacity of lifting device. Failure to do so may cause personal injury.

NOTE

Make sure diamond shaped seal (12) is fully seated in groove.

6. ATTACH SUITABLE LIFTING DEVICE TO LIFTER EYE (13) AND INSTALL CYLINDER HEAD (6).
7. SEAT CYLINDER HEAD (6) ON DIAMOND DOWEL (14) AND ROUND DOWEL (15) UNTIL FULL CONTACT IS MADE WITH CYLINDER HEAD GASKET (3).

CYLINDER HEAD REPLACEMENT (CONT)

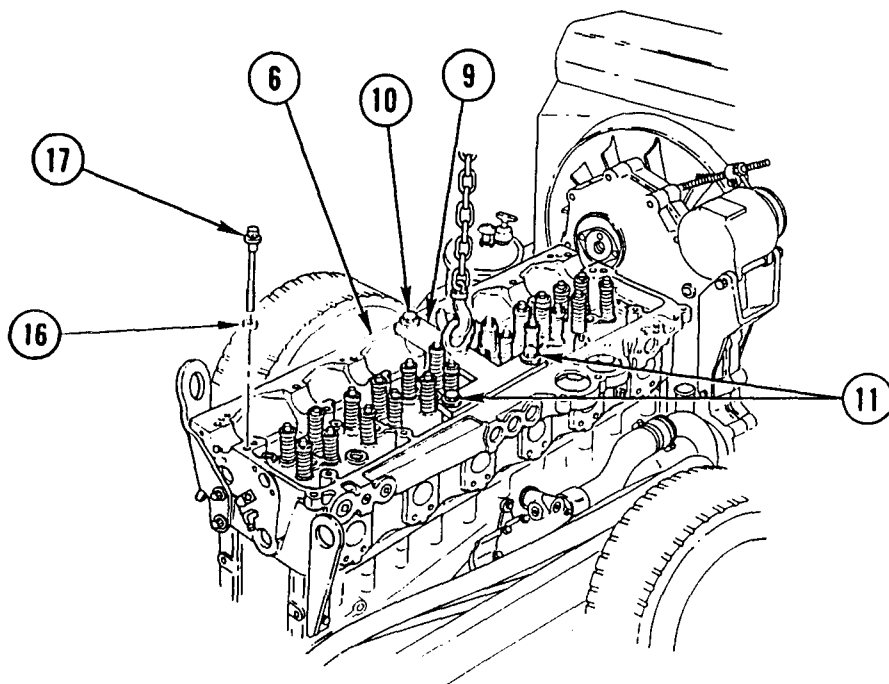

8. REMOVE LIFTING DEVICE.

NOTE

If cylinder head other than one removed, or if resurfaced cylinder head is being installed, three nuts retaining adjustable idler gear (page 12-99) must be loosened before installing and tightening camshaft drive gear retaining bolt. Notify general support maintenance to perform adjustment.

9. REMOVE THREE BOLTS (10 AND 11) AND LIFTER (9).
10. LUBRICATE THREADS OF 38 CYLINDER HEAD BOLTS AND BOLT-HEAD CONTACT AREAS WITH SMALL AMOUNT OF INTERNATIONAL COMPOUND NO. 2.
11. INSTALL 38 WASHERS (16) ON 38 BOLTS (17) AND INSTALL 38 BOLTS (17) IN CYLINDER HEAD (6).

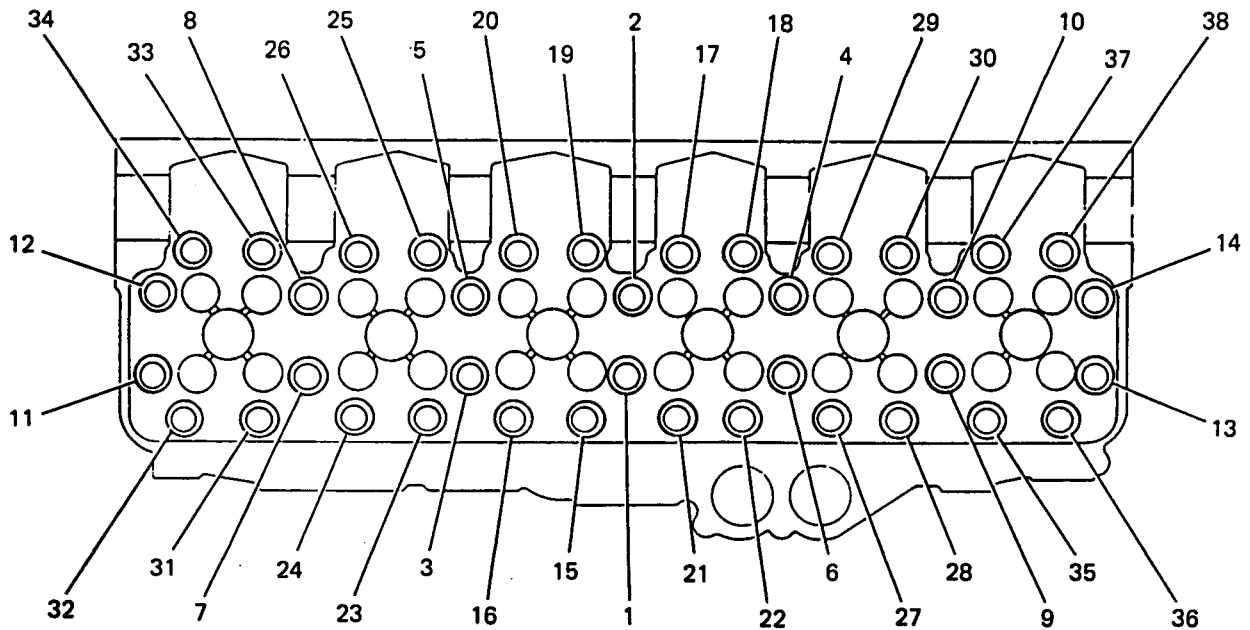

12. TIGHTEN 38 BOLTS TO 185-210 LB-FT (250-285 N.m) IN SEQUENCE SHOWN.

13. REPEAT TIGHTENING SEQUENCE.

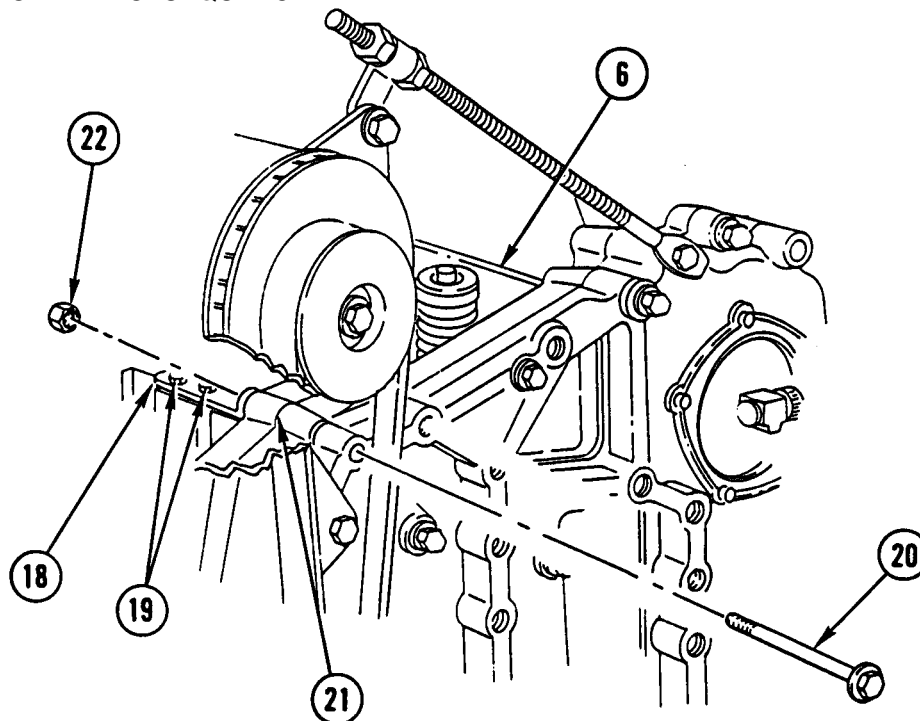

14. INSTALL BRACKET (18) ON CYLINDER HEAD (6) AND INSTALL TWO BOLTS (19). TIGHTEN BOLTS TO 43-54 LB-FT (58-73 N.m).

15. INSTALL BOLT (20) THRU GEAR CASE COVER AND GEAR HOUSING ASSEMBLY (21). INSTALL NUT (22). TIGHTEN NUT TO 43-54 LB-FT (58-73 N.m).

CYLINDER HEAD REPLACEMENT (CONT)

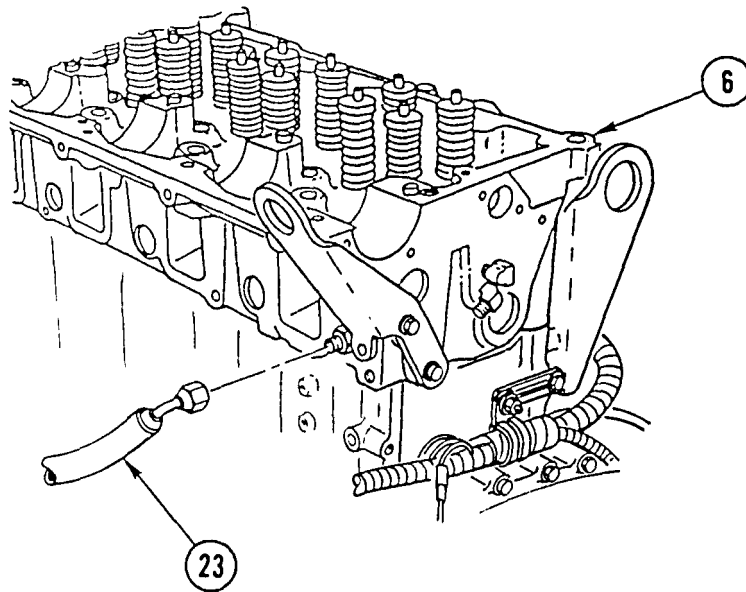

16. CONNECT AIR COMPRESSOR HOSE (23) TO CYLINDER HEAD (6).

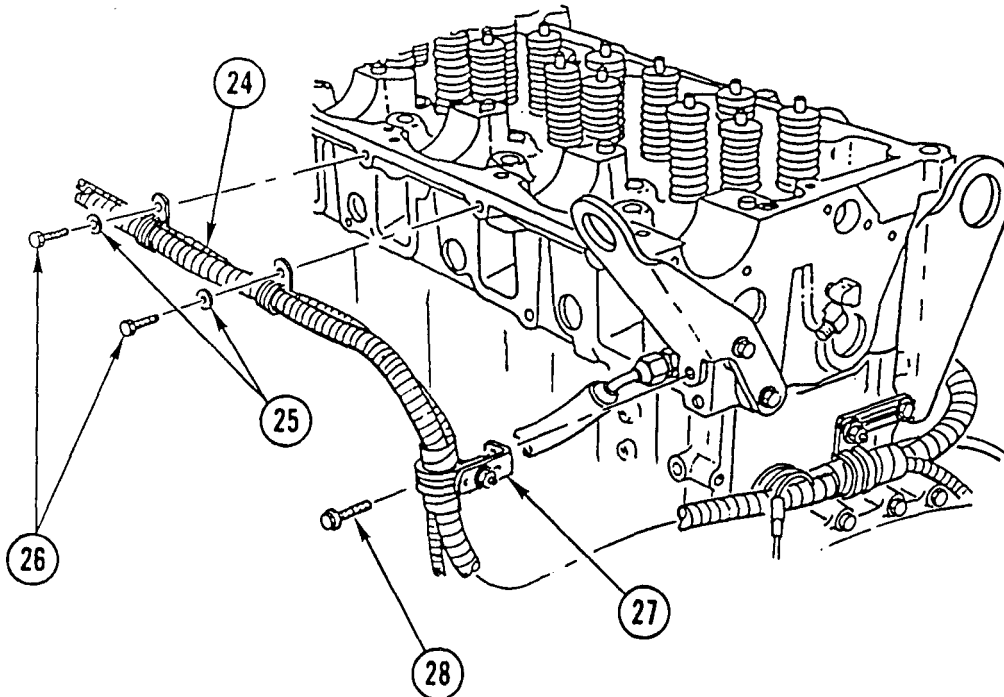

17. POSITION WIRING HARNESS (24) IN PLACE AND INSTALL TWO WASHERS (25) AND TWO BOLTS (26).
18. POSITION BRACKET (27) IN PLACE AND INSTALL BOLT (28).

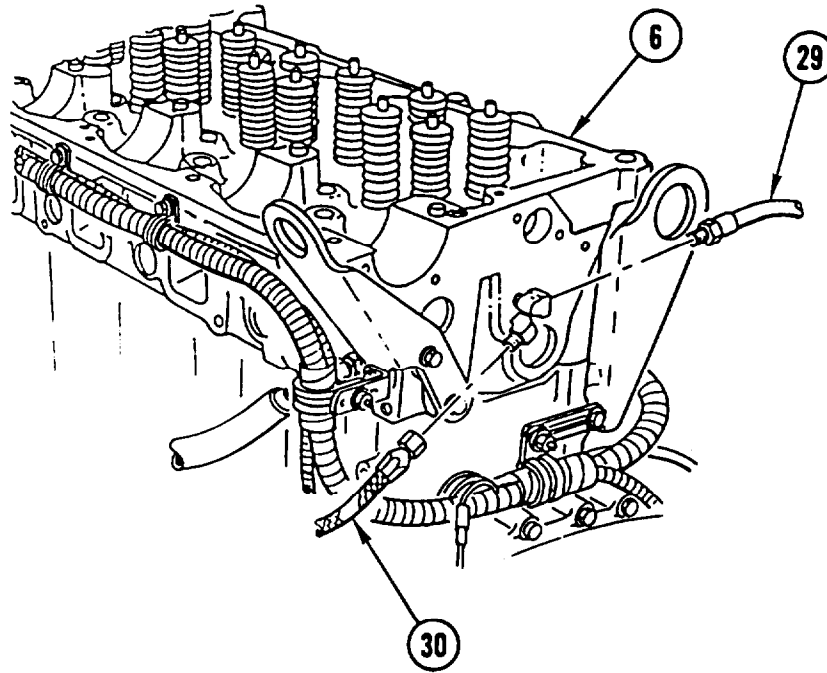

19. CONNECT TWO FUEL LINES (29 AND 30) TO CYLINDER HEAD (6).

NOTE

Follow-on Maintenance:

- Install camshaft and bearings (page 3-162).
- Install injector (page 3-108).
- Install injector wiring harness (page 4-2).
- Install water level sensor (TM 9-2320-363-20).
- Install thermostat and thermostat housing cover (TM 9-2320-363-20).
- Install exhaust manifold (page 3-67 or 3-70.1).
- Connect air compressor cooling lines (TM 9-2320-363-20).
- Install air intake manifold (page 3-61 or 3-66.1).
- Install alternator (TM 9-2320-363-20).
- Install transmission tunnel access cover (TM 9-2320-363-20).

AIR COMPRESSOR DRIVE REPLACEMENT AND REPAIR

This task covers: a. Removal b. Disassembly c. Cleaning d. Repair e. Assembly f. Inspection
g. Installation

Tools and Special Equipment:

Shop Equipment, SC 4910-95-CL-A31
 Tool Kit, SC 5180-90-CL-N05
 Air Compressor Service Set, J38310-A
 Holding Fixture, Appendix C, Item 2

References:

TM 9-2320-363-20

Equipment Condition:

Reference	Condition Description
TM 9-2320-363-20	Air Compressor Removed
Page 7-2	Power Steering Pump Removed

Materials/Parts:

Gasket P/N 8929299
 Bearing P/N FPF22264

REMOVAL

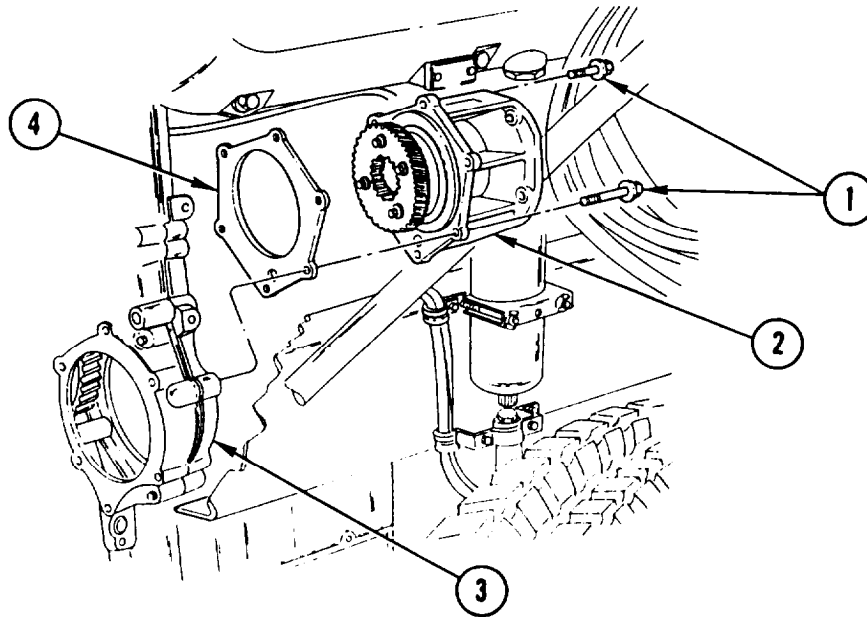

NOTE

If necessary, use soft-nosed mallet to tap air compressor drive to aid in removal.

1. REMOVE SIX BOLTS (1) AND AIR COMPRESSOR DRIVE (2) FROM GEAR HOUSING ASSEMBLY (3).
2. REMOVE AND DISCARD GASKET (4).

DISASSEMBLY

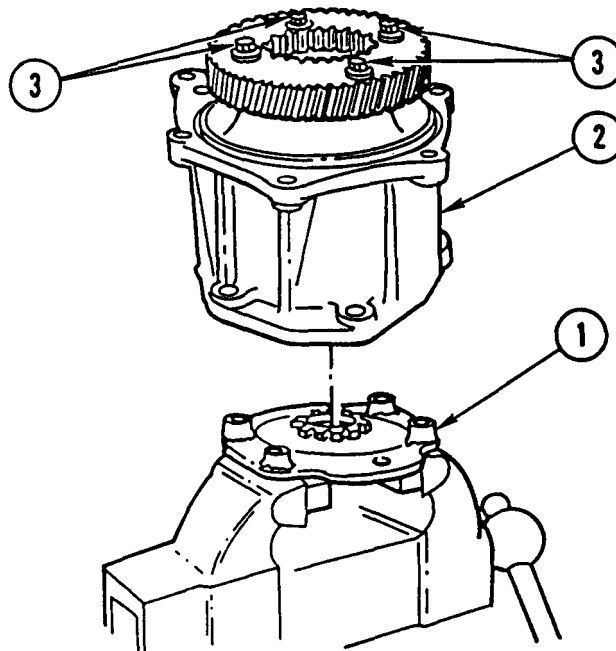

1. SECURE HOLDING FIXTURE (1) IN VISE.
2. POSITION AIR COMPRESSOR DRIVE (2) ON HOLDING FIXTURE (1), ENGAGING INTERNAL TEETH OF DRIVE HUB WITH HOLDING FIXTURE HUB.
3. LOOSEN FOUR DRIVE GEAR RETAINING BOLTS (3).

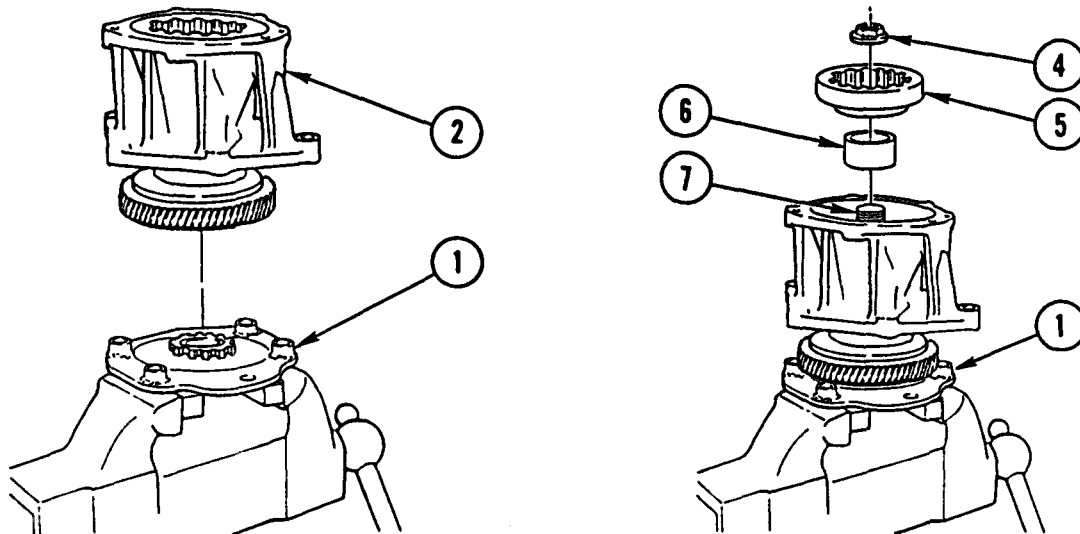

4. TURN AIR COMPRESSOR DRIVE (2) OVER AND POSITION AIR COMPRESSOR DRIVE (2) ON HOLDING FIXTURE (1), ENGAGING INTERNAL TEETH OF DRIVE GEAR WITH HOLDING FIXTURE HUB.
5. REMOVE DRIVE HUB RETAINING NUT (4), DRIVE HUB (5), AND SPACER RING (6) FROM DRIVE SHAFT (7).

AIR COMPRESSOR DRIVE REPLACEMENT AND REPAIR (CONT)

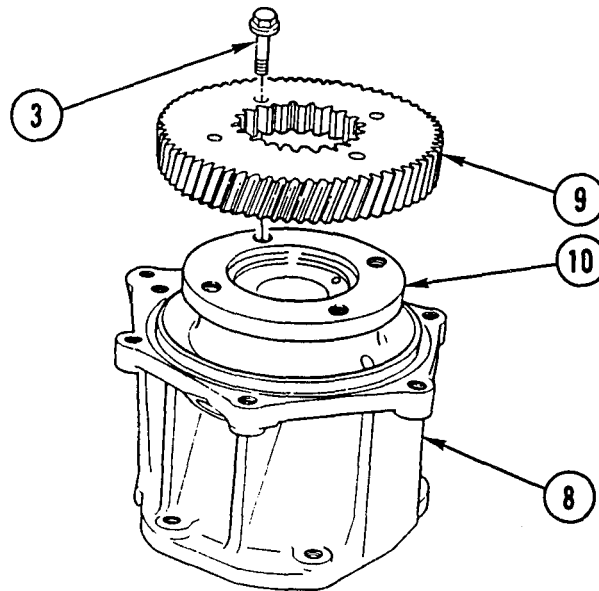

6. REMOVE AIR COMPRESSOR DRIVE HOUSING (8) FROM HOLDING FIXTURE AND PLACE ON BENCH.
7. REMOVE FOUR DRIVE GEAR RETAINING BOLTS (3) AND DRIVE GEAR (9) FROM DRIVE SHAFT FLANGE (10).

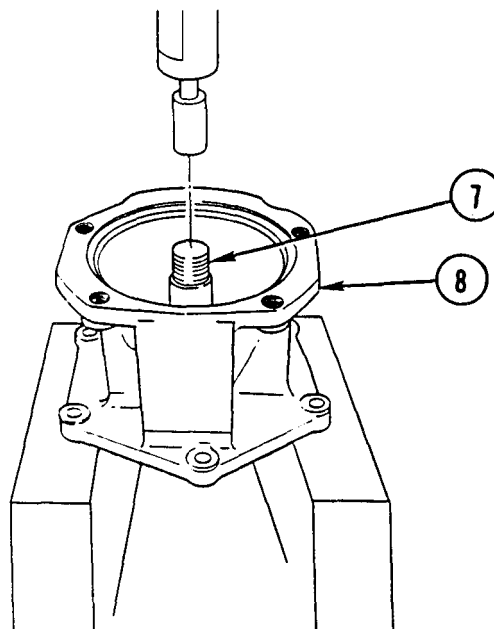

CAUTION
Remove and discard ball bearing assembly whenever drive shaft is removed.
Failure to do so may cause damage to equipment.

8. PLACE AIR COMPRESSOR DRIVE HOUSING (8) ON PRESS BED, AS SHOWN. PRESS DRIVE SHAFT (7) OUT OF BALL BEARING ASSEMBLY.

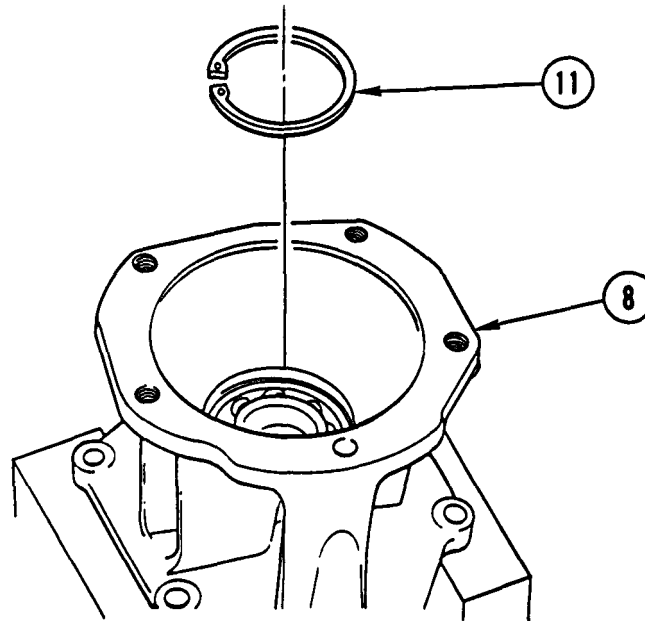

9. REMOVE BEARING RETAINING RING (11) FROM AIR COMPRESSOR DRIVE HOUSING (8).

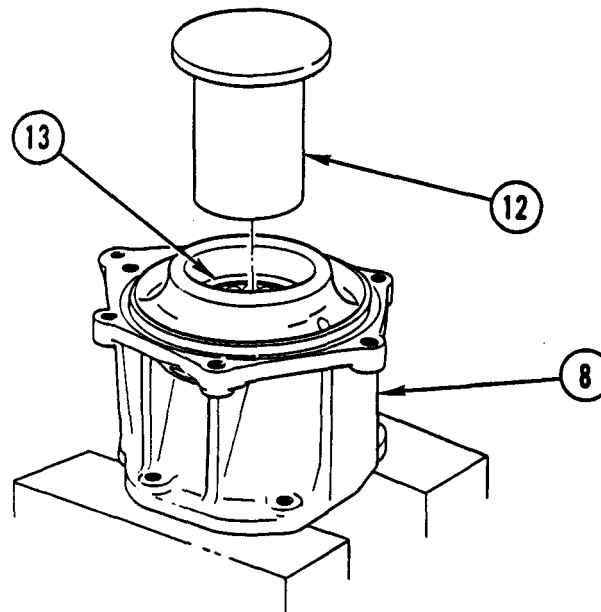

10. SUPPORT AIR COMPRESSOR DRIVE HOUSING (8) ON PRESS BED, AS SHOWN. USING NARROW END OF BALL BEARING INSTALLER (12) FROM SERVICE SET, PRESS BEARING (13) FROM HOUSING. DISCARD BALL BEARING ASSEMBLY.

AIR COMPRESSOR DRIVE REPLACEMENT AND REPAIR (CONT)

CLEANING

Use general cleaning methods to clean all parts (page 2-30).

REPAIR

Use general repair methods to repair damaged parts (page 2-33).

ASSEMBLY

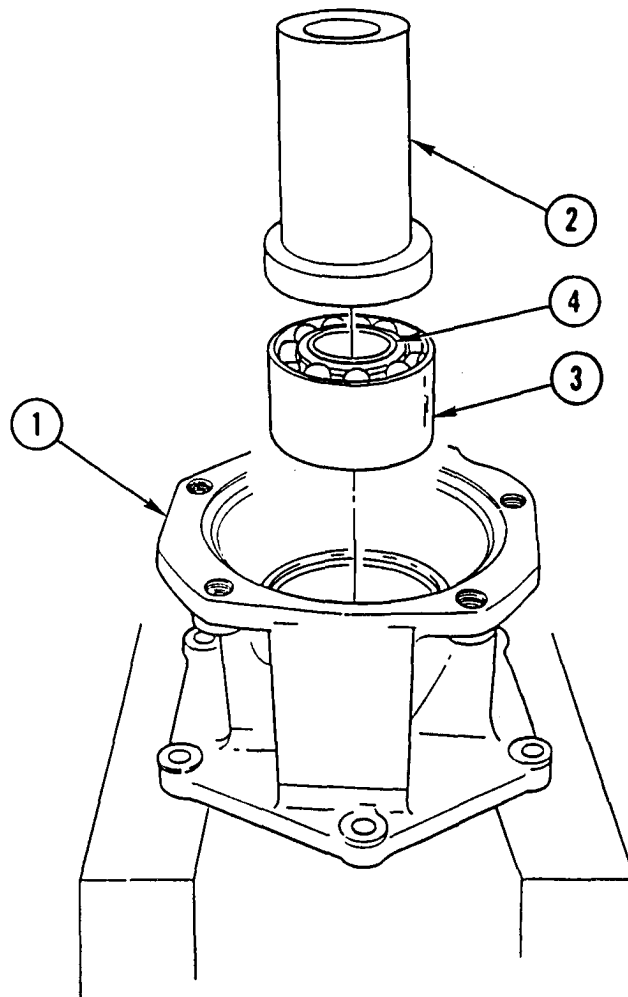

CAUTION

Do not remove plastic sleeve from ball bearing before installation. Sleeve will be pushed out when drive shaft is installed.

1. SUPPORT AIR COMPRESSOR DRIVE HOUSING (1) ON PRESS BED, AS SHOWN. USING WIDE END OF BALL BEARING INSTALLER (2) FROM SERVICE SET, PRESS NEW BEARING (3) AND PLASTIC SLEEVE (4) INTO AIR COMPRESSOR DRIVE HOUSING (1) UNTIL BEARING (3) OUTER RACE IS FIRMLY SEATED AGAINST AIR COMPRESSOR DRIVE HOUSING (1) SHOULDER.

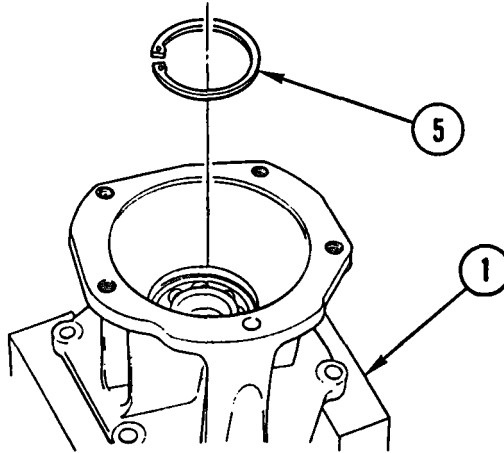

NOTE

Make sure bearing retaining ring is completely seated in air compressor drive groove.

2. INSTALL BEARING RETAINING RING (5), BEVELED FACE UP, IN AIR COMPRESSOR DRIVE HOUSING (1) GROOVE.

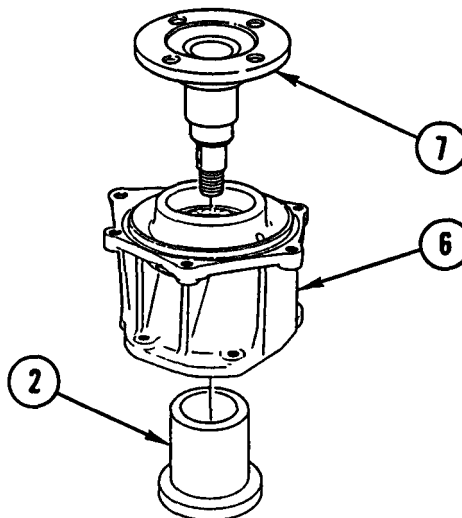

3. PLACE WIDE END OF BALL BEARING INSTALLER (2) FROM SERVICE SET ON PRESS BED. PLACE AIR COMPRESSOR DRIVE (6) ON BEARING INNER RACE AND ONTO NARROW END OF BALL BEARING INSTALLER (2).

NOTE

Make sure face of ball bearing installer is centered on bearing inner race so it does not obstruct removal of plastic sleeve as drive shaft is pressed into bearing.

4. POSITION DRIVE SHAFT (7) IN BEARING INNER RACE CAREFULLY. PRESS DRIVE SHAFT (7) INTO BEARING UNTIL DRIVE SHAFT SHOULDER IS FIRMLY SEATED AGAINST BEARING INNER RACE. REMOVE AIR COMPRESSOR DRIVE (6) FROM BALL BEARING INSTALLER (2) AND REMOVE PLASTIC SLEEVE FROM INSIDE INSTALLER (2). DISCARD PLASTIC SLEEVE.

AIR COMPRESSOR DRIVE REPLACEMENT AND REPAIR (CONT)

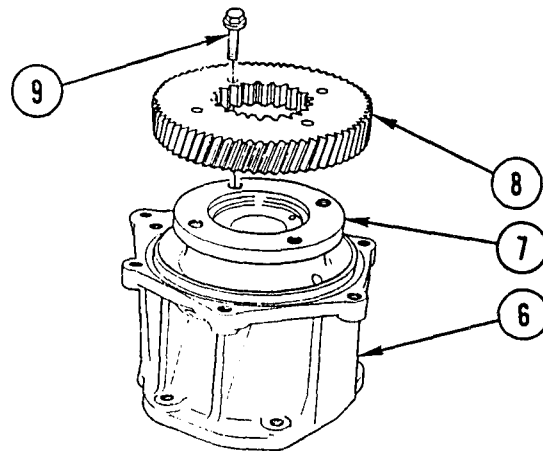

NOTE

Do not use lubricant on threads of bolts or drive gear flange.

5. PLACE AIR COMPRESSOR DRIVE (6) ON BENCH, AS SHOWN. POSITION DRIVE GEAR (8) ON DRIVE SHAFT (7) FLANGE AND ALINE BOLT HOLES. INSTALL FOUR BOLTS (9) HAND-TIGHT.

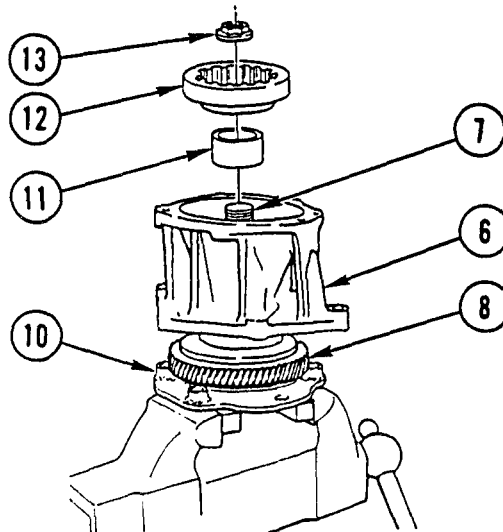

6. SECURE HOLDING FIXTURE (10) IN VISE. INSTALL AIR COMPRESSOR DRIVE (6) ON HOLDING FIXTURE (10), ENGAGING INTERNAL TEETH OF DRIVE GEAR (8) WITH HOLDING FIXTURE (10) HUB.
7. SEAT SPACER RING (11) ON DRIVE SHAFT (7) AGAINST BEARING INNER RACE.

NOTE

Do not use lubricant on threads of shaft or retaining nut.

8. PLACE DRIVE HUB (12) ON DRIVE SHAFT (7) AND INSTALL RETAINING NUT (13). TIGHTEN RETAINING NUT TO 220-255 LB-FT (300-345 N.m).

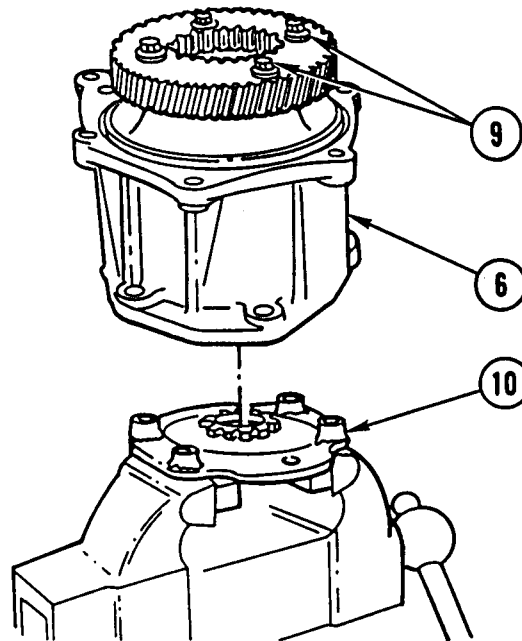

- TURN AIR COMPRESSOR DRIVE (6) OVER. POSITION AIR COMPRESSOR DRIVE (6) ON HOLDING FIXTURE (10), ENGAGING INTERNAL TEETH OF DRIVE HUB WITH HOLDING FIXTURE HUB. TIGHTEN BOLTS (9) TO 43-54 LB-FT (58-73 N.m).

INSPECTION

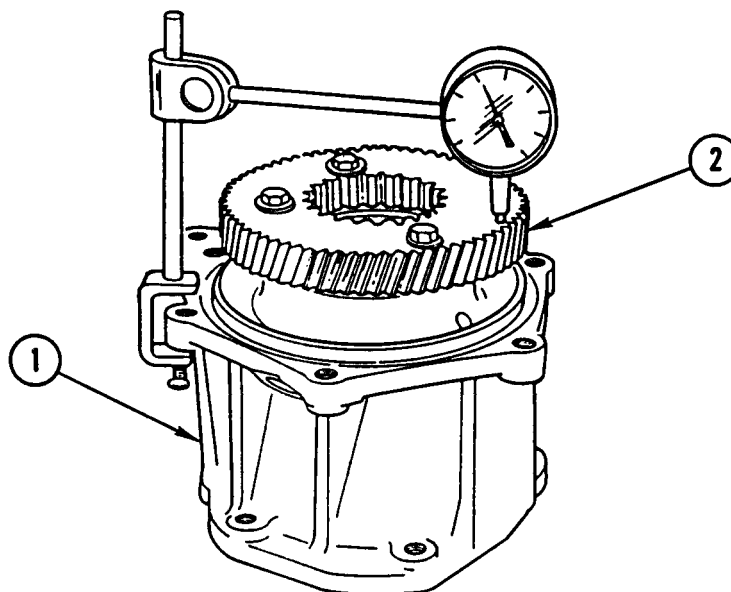

- REMOVE AIR COMPRESSOR DRIVE ASSEMBLY (1) FROM HOLDING FIXTURE. POSITION AIR COMPRESSOR DRIVE ASSEMBLY (1) ON SUITABLE FLAT SURFACE, AS SHOWN.
- MEASURE DRIVE GEAR (2) BY ZEROING DIAL INDICATOR. ROTATE DRIVE GEAR (2) TWO FULL REVOLUTIONS. AS DRIVE GEAR IS ROTATED, DIAL INDICATOR MAY REGISTER TO LEFT AND RIGHT OF ZERO. TOTAL DIAL INDICATOR NEEDLE MOVEMENT EQUALS TOTAL INDICATED RUNOUT (TIR). MAXIMUM ALLOWABLE TIR IS 0.003 IN. (0.08 mm).

AIR COMPRESSOR DRIVE REPLACEMENT AND REPAIR (CONT)

INSTALLATION

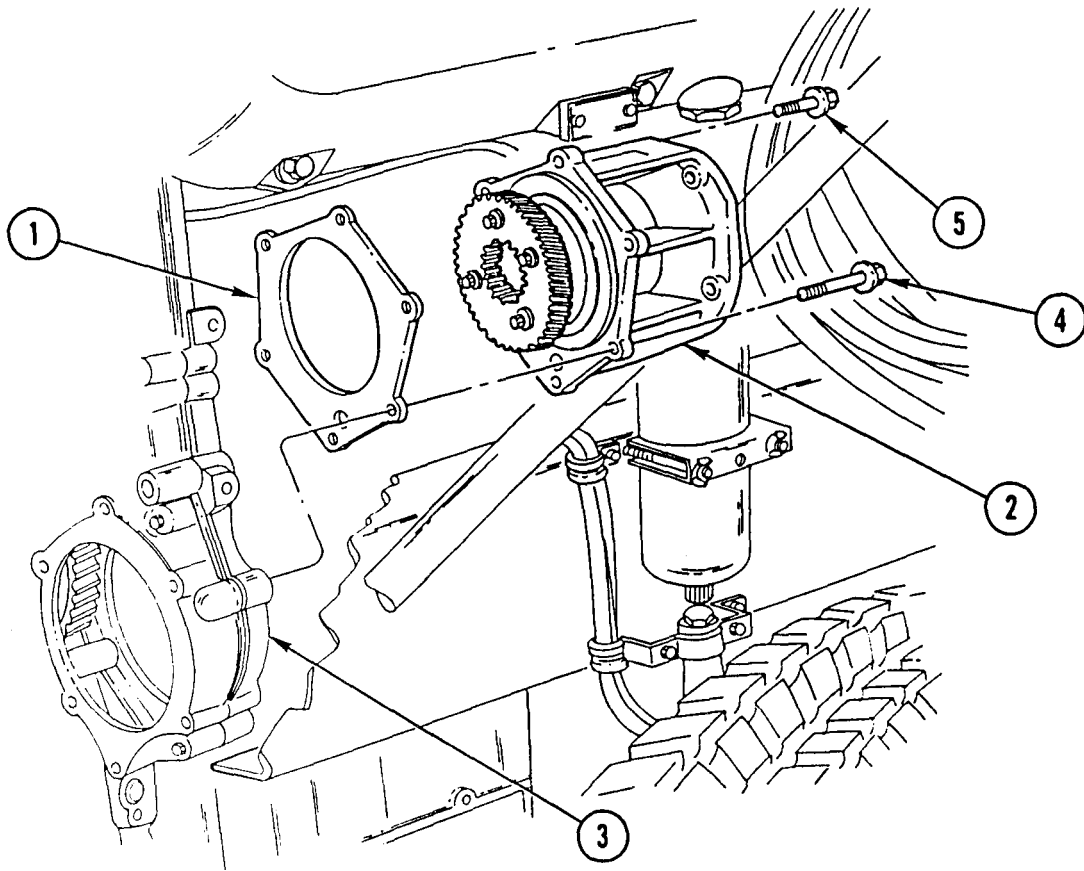

NOTE

- Make sure all old gasket material from air compressor drive assembly mounting flange and gear housing mating area is removed.
- If necessary, rotate drive gear slightly to engage gear teeth of bull gear and fully seat pilot ring of air compressor-drive in gear-housing.

1. POSITION NEW GASKET (1) ON FLANGE OF AIR COMPRESSOR DRIVE (2). POSITION AIR COMPRESSOR DRIVE (2) ON GEAR HOUSING (3).
2. INSTALL FIVE BOLTS (4). INSTALL SHORTER BOLT (5) IN 1 O'CLOCK POSITION WHEN VIEWED FROM AIR COMPRESSOR END OF AIR COMPRESSOR DRIVE (2). TIGHTEN BOLTS TO 43-54 LB-FT (58-73 N.m).

NOTE

Follow-on Maintenance:

- Install power steering pump (Page 7-2).
- Install air compressor (TM 9-2320-363-20).

TURBOCHARGER REPLACEMENT

This task covers: a. Removal b. Cleaning c. Inspection d. Installation

INITIAL SETUP

Tools and Special Equipment:

Shop Equipment, SC 4910-95-CL-A31
 Tool Kit, SC 5180-90-CL-N05
 Torque Wrench Adapter, 11663358-2
 Turbocharger Inlet Shield, J26554-A

Personnel Required: (2)

General Safety Instructions:

Materials/Parts:

Seal, Clamp	P/N KYX00-5833
Gasket, Exhaust Inlet	P/N 8929529
Gasket, Drain Tube	P/N 8929285
Oil, Engine	Appendix B, Item 37
Tape, Masking	Appendix B, Item 58

WARNING

- Hot turbocharger and exhaust pipe can cause serious burns. Do not work on exhaust system until it is cool. To do so could result in serious injury to personnel.
- Turbocharger weighs 50 lb (23 kg). Use two persons or suitable lifting device during removal or installation to prevent personal injury or damage to turbocharger.
- Use turbocharger inlet shield when servicing turbocharger. Failure to do so could result in serious injury to personnel or damage to turbocharger.

TURBOCHARGER REPLACEMENT (CONT)

REMOVAL

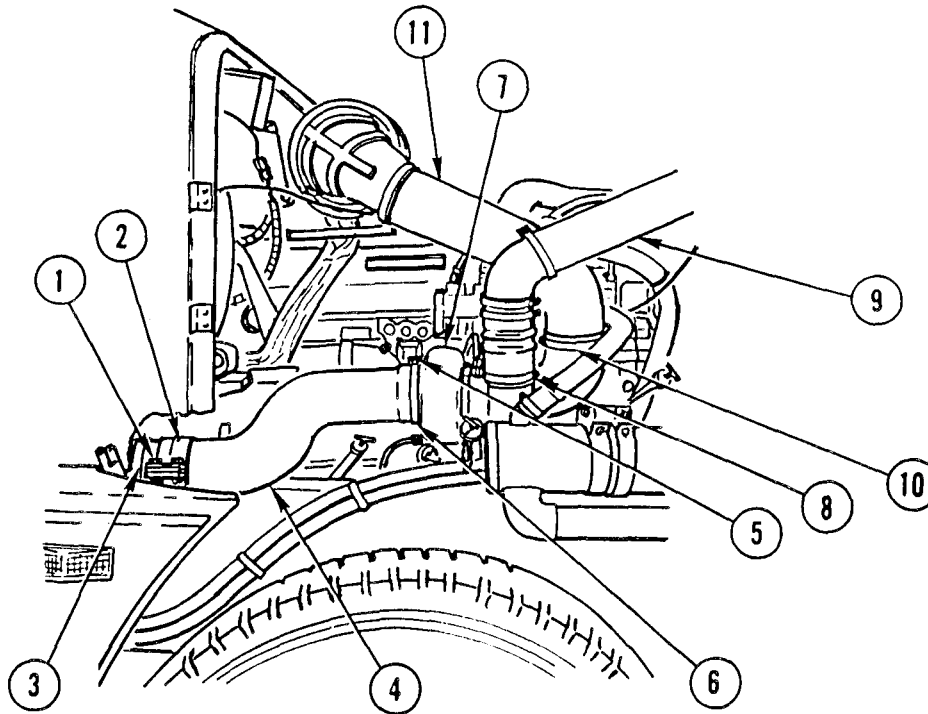

WARNING

Hot turbocharger and exhaust pipe can cause serious burns. Do not work on exhaust system until it is cool. To do so could result in serious injury to personnel.

1. REMOVE TWO BOLTS (1) AND SEAL CLAMP (2) FROM FLEX PIPE (3) AND OUTLET PIPE (4). DISCARD SEAL CLAMP.
2. REMOVE NUT (5) AND VEE CLAMP (6) FROM OUTLET PIPE (4) AND TURBOCHARGER (7).
3. LOOSEN CLAMP (8) AND REMOVE INTERCOOLER DUCT (9) FROM T TURBOCHARGER (7).

WARNING

Use turbocharger inlet shield when servicing turbocharger. Failure to do so could result in serious injury to personnel or damage to turbocharger.

4. LOOSEN CLAMP (10), REMOVE AIR INLET DUCT (11) FROM TURBOCHARGER (7), AND INSTALL TURBOCHARGER INLET SHIELD.

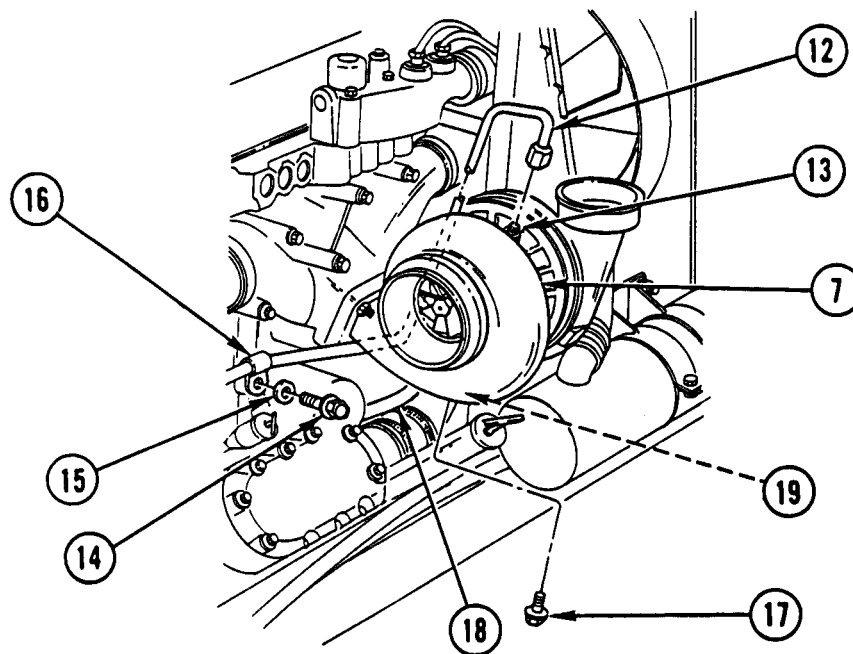

5. DISCONNECT OIL SUPPLY LINE (12) FROM FITTING (13) ON TOP OF TURBOCHARGER (7).
6. REMOVE BOLT (14) AND WASHER (15) FROM OIL SUPPLY LINE CLIP (16) ON OIL FILTER ADAPTER UPPER MOUNTING LEG AND MOVE AWAY FROM TURBOCHARGER (7).
7. REMOVE TWO BOLTS (17) SECURING OIL DRAIN LINE (18) TO BOTTOM OF TURBOCHARGER (7).
8. REMOVE AND DISCARD GASKET (19).

TURBOCHARGER REPLACEMENT (CONT)

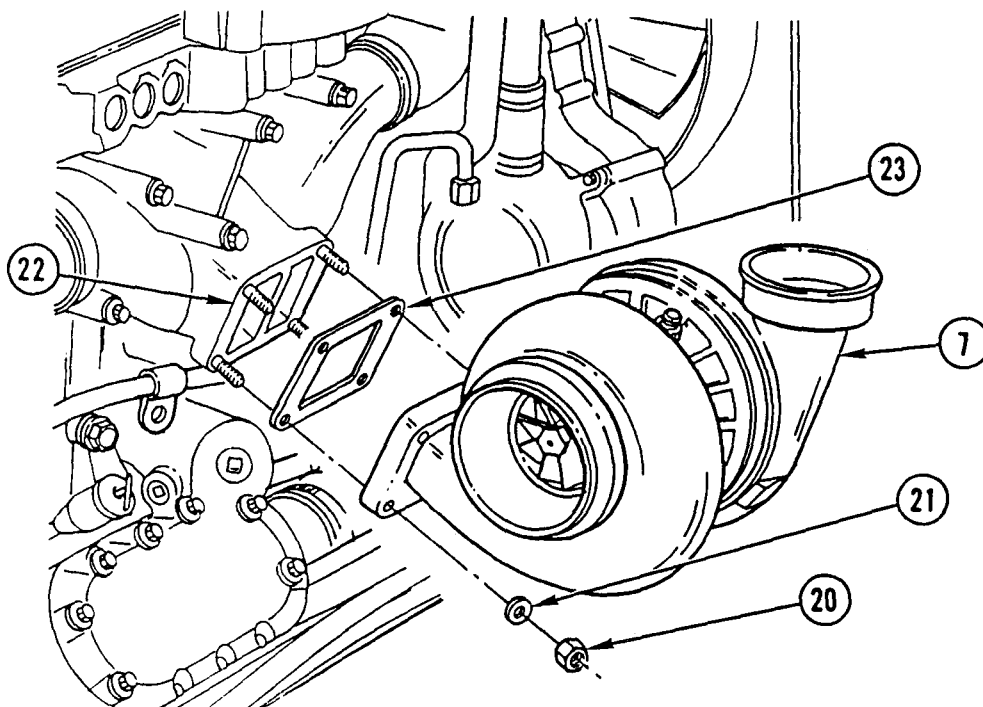

9. REMOVE FOUR NUTS (20) AND FOUR WASHERS (21) SECURING TURBOCHARGER (7) TO EXHAUST MANIFOLD (22).

WARNING

Turbocharger weighs 50 lb (110 kg). Use two persons or suitable lifting device during removal to prevent personal injury or damage to turbocharger.

10. REMOVE TURBOCHARGER (7) AND GASKET (23). DISCARD GASKET.

11. TAPE ALL OPENINGS OF TURBOCHARGER (7).

CLEANING

Use general cleaning methods to clean all parts (page 2-30).

INSPECTION

1. INSPECT TURBOCHARGER MOUNTING STUDS ON EXHAUST MANIFOLD FOR DAMAGE OR LOOSENESS.
2. REMOVE AND REPLACE DAMAGED STUD(S). TIGHTEN STUD(S), IF LOOSE. IF DAMAGED, REMOVE THREADED TURBOCHARGER STUD(S) BY UNSCREWING. USING TWO NUTS, ONE AS JAM NUT, THREAD NEW STUD(S) INTO EXHAUST MANIFOLD UNTIL UNTHREADED PORTION OF STUD IS BOTTOMED AGAINST MOUNTING FLANGE, TIGHTEN STUD(S) TO 18-24 LB-FT (25-32 N.m).

3. INSPECT ALL PARTS FOR WEAR OR DAMAGE.

INSTALLATION

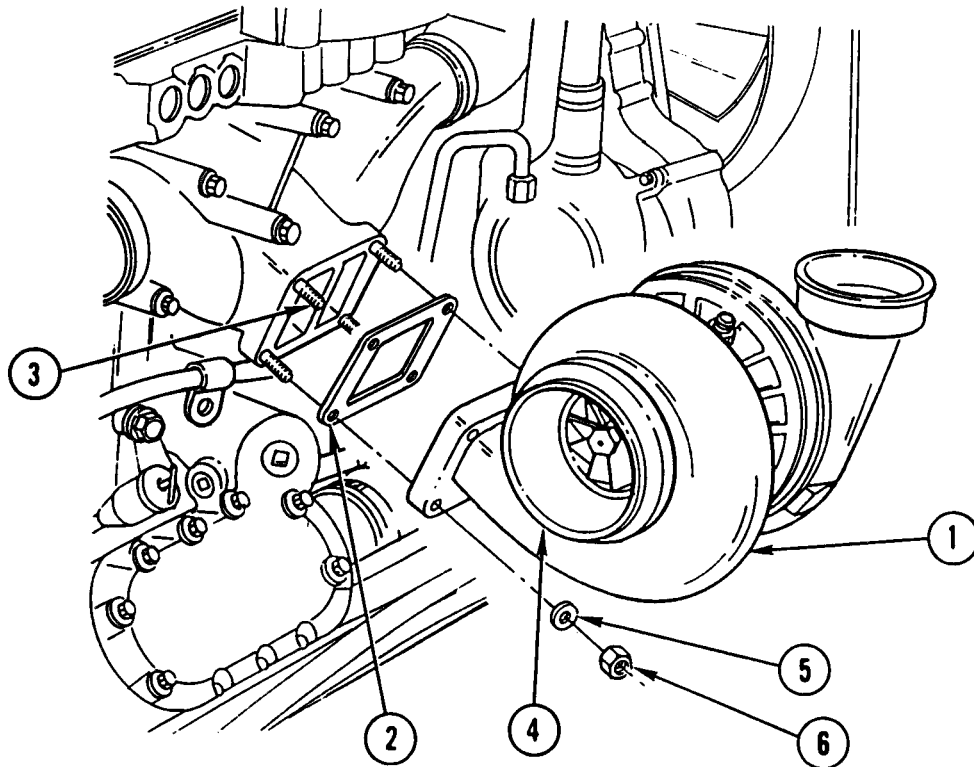

WARNING

Use turbocharger inlet shield when servicing turbocharger. Failure to do so could result in serious injury to personnel or damage to turbocharger.

1. REMOVE TAPE FROM ALL OPENINGS OF TURBOCHARGER (1) AND INSTALL TURBOCHARGER INLET SHIELD.
2. POSITION NEW GASKET (2) ON EXHAUST MANIFOLD TURBOCHARGER MOUNTING FLANGE STUDS (3).

WARNING

Turbocharger weighs 50 lb (110 kg). Use two persons or suitable lifting device during installation to prevent personal injury or damage to turbocharger.

3. PLACE TURBOCHARGER (1) ON MOUNTING FLANGE STUDS (3) WITH EXHAUST OUTLET SIDE (4) FACING TOWARD REAR.
4. INSTALL FOUR FLAT WASHERS (5) AND FOUR NUTS (6) ON MOUNTING FLANGE STUDS (3). TIGHTEN NUTS TO 43-54 LB-FT (58-73 N.m).

TURBOCHARGER REPLACEMENT (CONT)

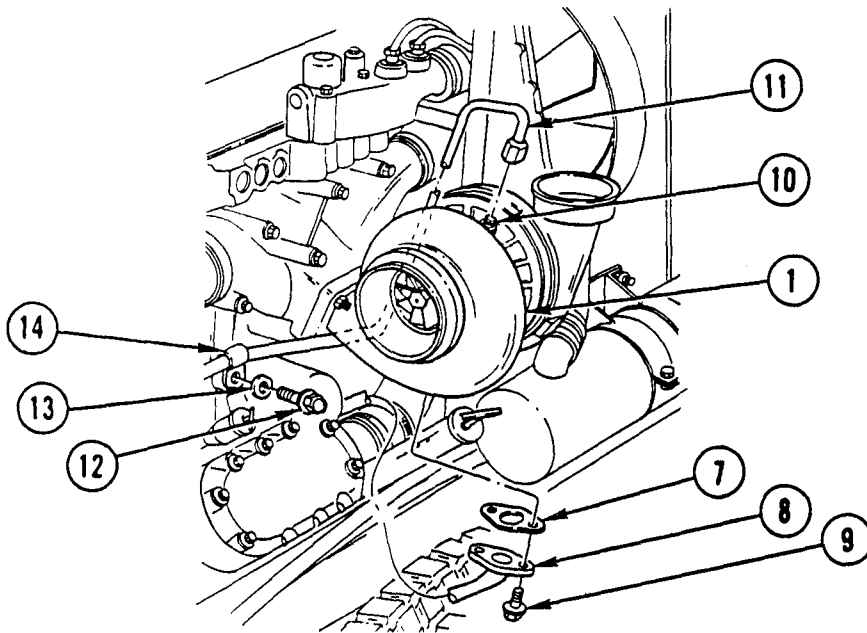

5. INSTALL NEW GASKET (7) AND CONNECT OIL DRAIN LINE (8) TO BOTTOM OF TURBOCHARGER (1) WITH TWO BOLTS (9). TIGHTEN BOLTS TO 22-28 LB-FT (30-38 N.m).

CAUTION

- Do not use lubricant on inside of air inlet hose or hose contact surfaces of turbocharger compressor housing, intercooler, intercooler ducting, or intake manifold. Use of lubricant can cause hose to blow off turbocharger,
- Failure to lubricate turbocharger will result in premature failure.

6. CAREFULLY POUR HALF-PINT OF ENGINE LUBRICATING OIL INTO OIL INLET PORT (10) AT TOP OF TURBOCHARGER (1) WHILE MANUALLY ROTATING TURBOCHARGER COMPRESSOR WHEEL. CONNECT OIL SUPPLY LINE (11) AND REMOVE SPILLED OIL FROM TURBOCHARGER (1) AND EXHAUST MANIFOLD.
7. REMOVE TOP OIL FILTER ADAPTER MOUNTING BOLT (12) AND WASHER (13), INSTALL OIL SUPPLY LINE CLIP (14) ON OIL FILTER ADAPTER AND INSTALL WASHER (13) AND BOLT (12). TIGHTEN BOLT TO 43-54 LB-FT (58-73 N.m).

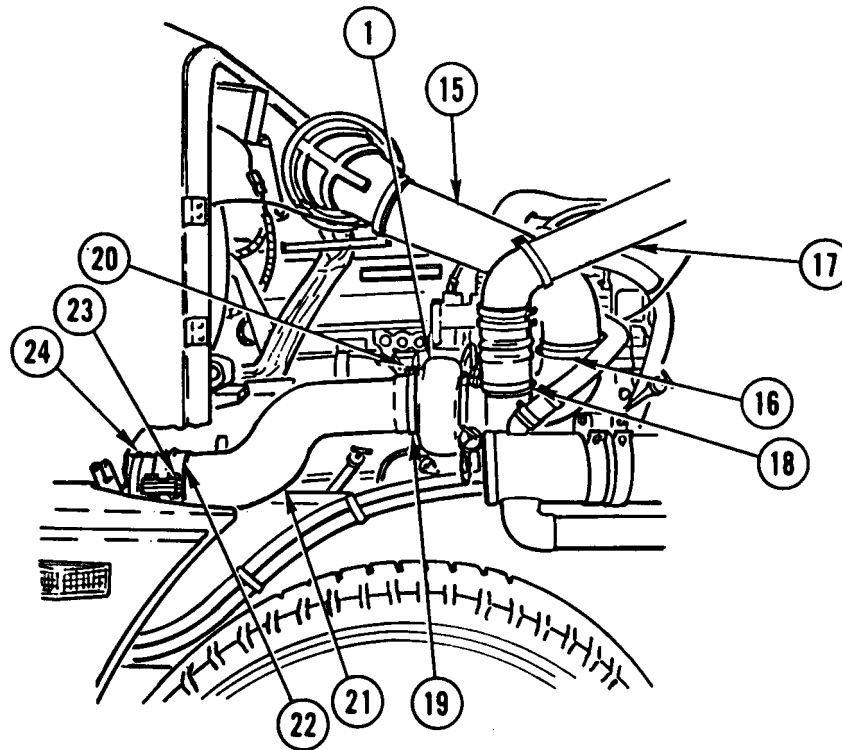

8. REMOVE TURBOCHARGER INLET SHIELD AND INSTALL AIR INLET DUCT (15) ON TURBOCHARGER (1). TIGHTEN CLAMP (16) TO 18-22 LB-FT (24-30 N.m).
9. INSTALL INTERCOOLER DUCT (17) ON TURBOCHARGER (1). TIGHTEN CLAMP (18) TO 18-22 LB-FT (24-30 N.m).
10. INSTALL VEECLAMP (19) AND NUT (20) BETWEEN OUTLET PIPE (21) AND TURBOCHARGER (1). TIGHTEN NUT TO 18-22 LB-FT (24-30 N.m).
11. INSTALL NEW SEAL CLAMP (22) AND TWO BOLTS (23) BETWEEN FLEX PIPE (24) AND OUTLET PIPE (21). TIGHTEN TWO BOLTS TO 18-22 LB-FT (24-30 N.m).

INJECTOR REPLACEMENT

This task covers: a. Removal b. Cleaning c. Inspection d. Installation

INITIAL SETUP

Tools and Special Equipment:

Shop Equipment, SC 4910-95-CL-A31
Tool Kit, SC 5180-90-CL-N05

Materials/Parts:

Ring, Seal	P/N 5234702
Ring, Seal	P/N 5234699
Tag, Identification	Appendix B, Item 55
oil, Lubricating	Appendix B, Item 37

References:

TM 9-2320-363-20

Equipment Condition:

Reference

Page 3-183

Condition Description

Rocker Arm Assemblies
Removed

General Safety Precautions:

<p>WARNING Eye protection must be worn to prevent fuel from getting in eyes.</p>

REMOVAL

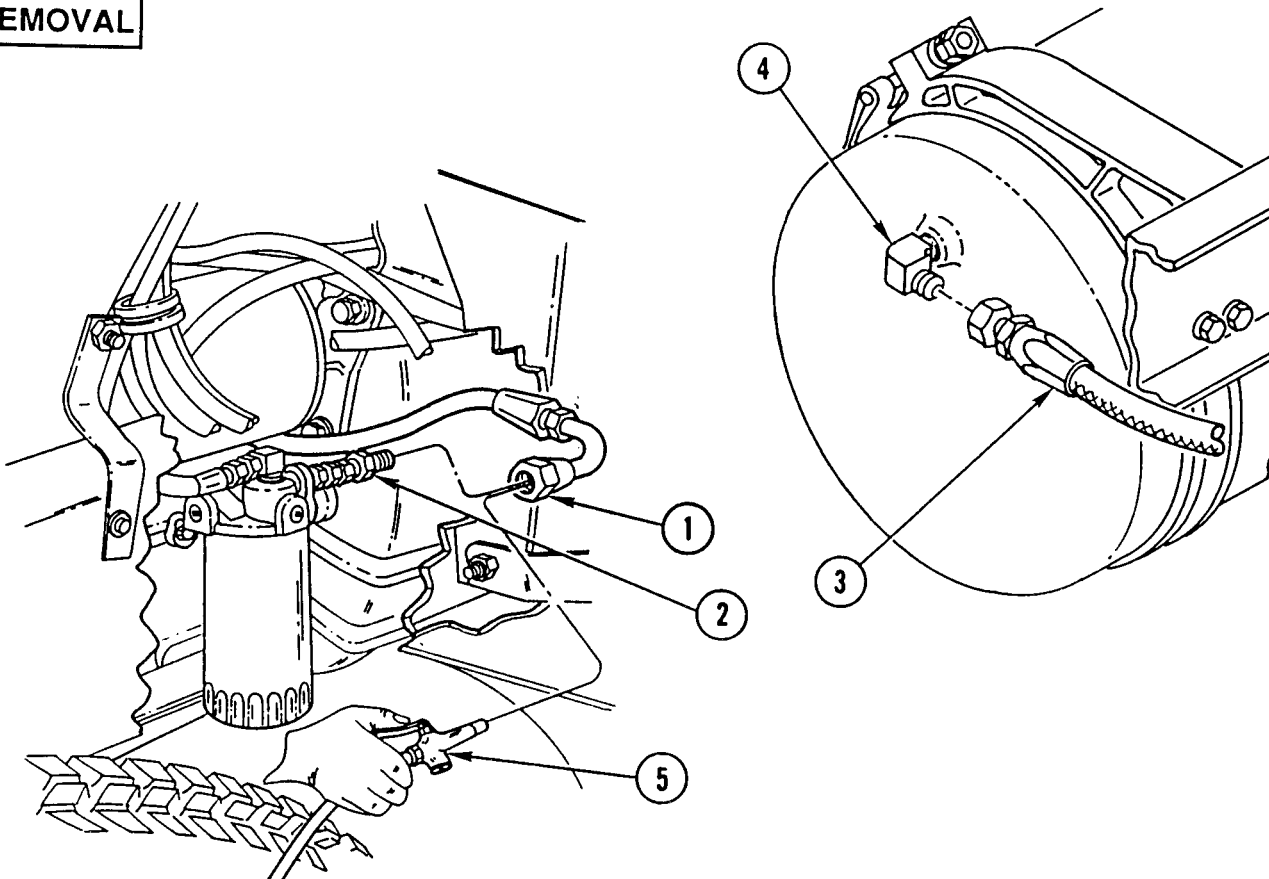

1. DISCONNECT FUEL SUPPLY HOSE (1) FROM FUEL CHECK VALVE FITTING (2).
2. DISCONNECT FUEL RETURN LINE (3) AT VEHICLE FUEL RETURN LINE CONNECTION (4).
3. PLACE FUEL RETURN LINE (3) IN SUITABLE CONTAINER TO COLLECT DRAINED FUEL.

WARNING

Eye protection must be worn to prevent fuel from getting in eyes.

CAUTION

Remove all fuel from cylinder head before removing injector to prevent fuel from entering cylinder.

NOTE

Do not exceed 20 psi when applying air pressure to fuel supply hose inlet.

4. USING AIR NOZZLE (5), APPLY LOW AIR PRESSURE TO FUEL SUPPLY HOSE TO PURGE REMAINING FUEL FROM CYLINDER HEAD.

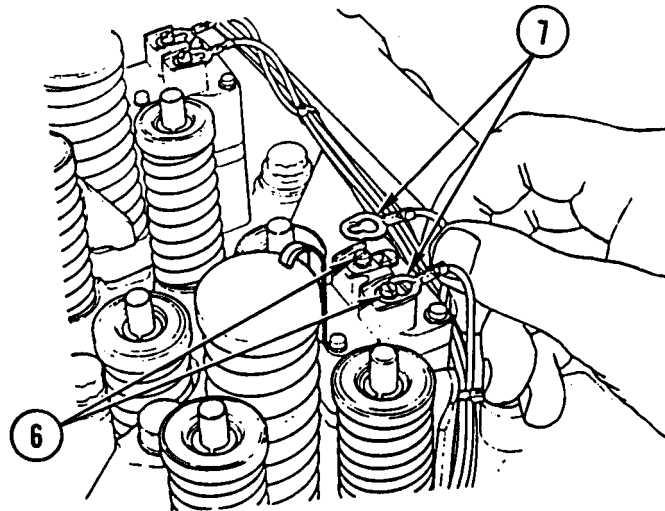

CAUTION

Use extreme care when handling injector to avoid costly damage from dropping or mishandling.

NOTE

- Do not remove screws from injector. Loosen screws enough to allow large opening in harness terminals to be moved under screw head for harness terminal removal.
- Tag wire terminals prior to removal to aid in installation.

5. LOOSEN TWO SCREWS (5) AND REMOVE INJECTOR HARNESS TERMINALS (7).

INJECTOR REPLACEMENT (CONT)

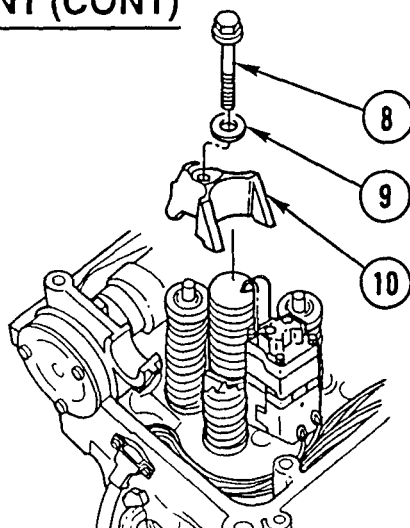

6. REMOVE HOLDDOWN BOLT (8), WASHER (9), AND HOLDDOWN CLAMP (10).

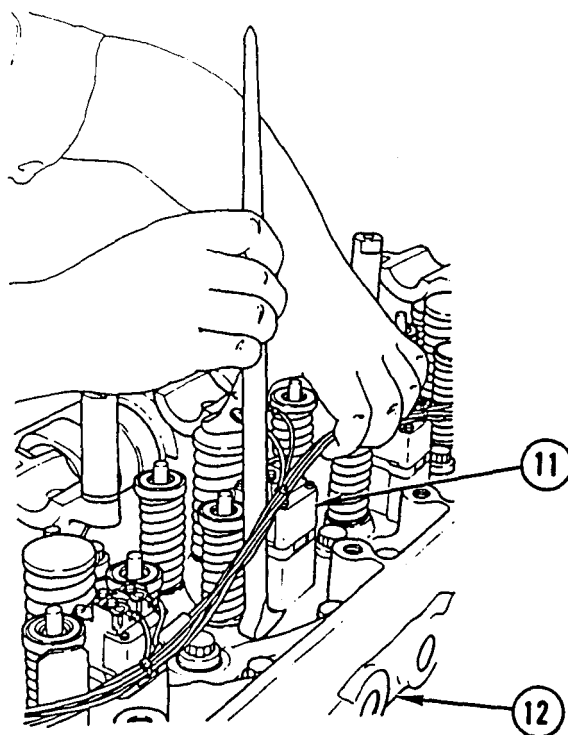

CAUTION

Use extreme care when handling injector to avoid costly damage by dropping or mishandling.

NOTE

Tag injector prior to removal to aid in installation.

7. LIFT INJECTOR (11) FROM SEAT IN CYLINDER HEAD (12) BY INSERTING PRY BAR UNDER INJECTOR BODY AS SHOWN.

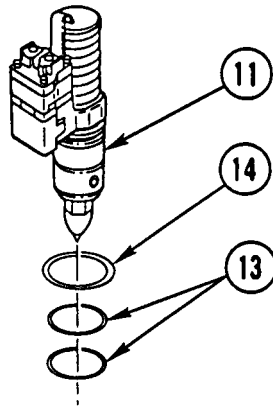

NOTE

Replace injector seal rings when replacing injector.

8. REMOVE AND DISCARD THREE INJECTOR SEAL RINGS (13 AND 14) FROM INJECTOR (11), REPEAT STEPS 5 THRU 8 FOR REMAINING INJECTORS.

CLEANING

Use general cleaning methods to clean all parts (page 2-30).

INSPECTION

Inspect all parts for wear or damage.

INSTALLATION

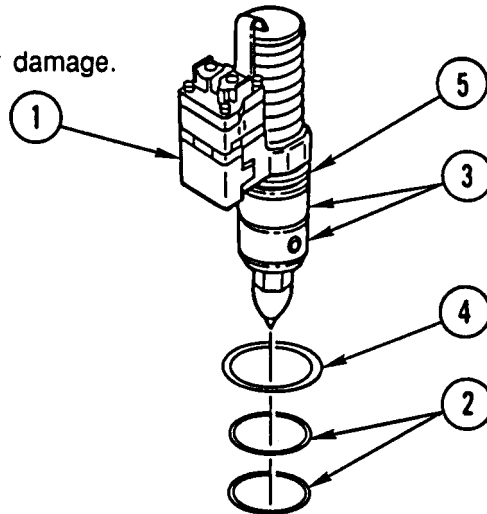

CAUTION

Make sure injector seal rings are not cut or nicked and are installed completely in grooves to prevent damage to equipment.

1. LUBRICATE THREE NEW INJECTOR SEAL RINGS LIGHTLY WITH ENGINE OIL AND INSTALL ON INJECTOR (1).
2. INSTALL TWO LOWER SEAL RINGS (2) IN TWO LOWER GROOVES (3).
3. INSTALL LARGER SEAL RING (4) IN UPPER GROOVE (5).

INJECTOR REPLACEMENT (CONT)

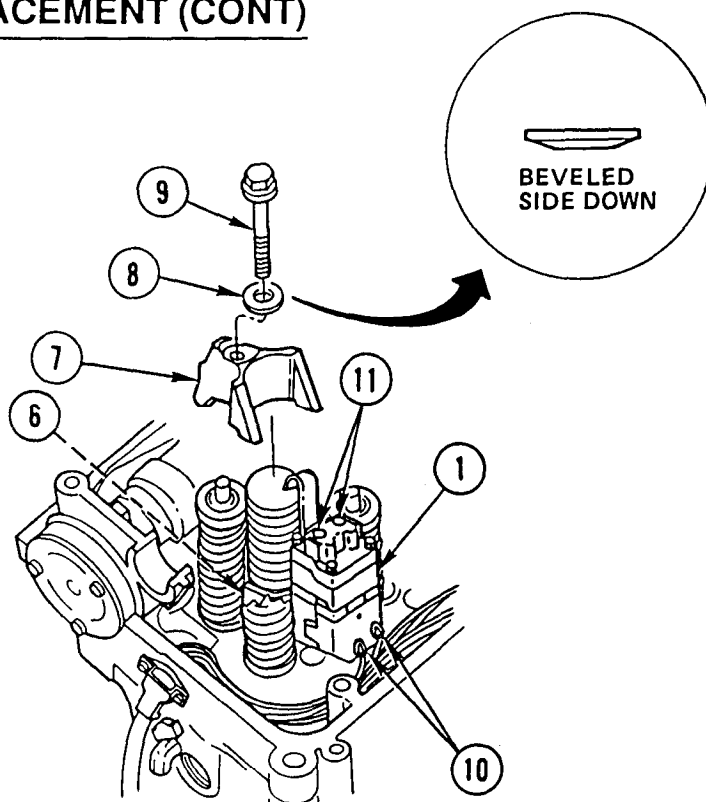

4. INSERT INJECTOR (1) INTO INJECTOR TUBE (6).
5. PRESS DOWN ON TOP OF INJECTOR FOLLOWER UNTIL INJECTOR IS FULLY SEATED IN INJECTOR TUBE (6).

CAUTION

- Position holddown clamp carefully so it does not contact or interfere with injector follower spring or intake valve springs. Failure to do so will result in equipment damage.
- To prevent damage to washer, install washer beveled side down.

6. INSTALL INJECTOR HOLDDOWN CLAMP (7) ON INJECTOR (1).
7. INSTALL WASHER (8) ON HOLDDOWN BOLT (9).
8. INSTALL HOLDDOWN BOLT (9) HAND-TIGHT.

CAUTION

Check position of injector and holddown clamp to ensure clearance between intake valve spring and injector follower spring. Failure to do so will result in equipment damage.

9. TIGHTEN HOLDDOWN BOLT (9) TO 43-49 LB-FT (58-66 N.m).

CAUTION

- Injector harness terminals should be bent upward before installation to avoid contacting surrounding surfaces and causing short circuits. However, do not bend harness terminals after installation to prevent damage to equipment.
- The following steps must be performed to provide clearance for engine retarder wiring harness.

10. BEND INJECTOR HARNESS TERMINAL (10) UPWARD, APPROXIMATELY 90 DEGREES.
11. INSTALL INJECTOR HARNESS TERMINAL (10) ON TWO SCREWS (11). TIGHTEN SCREWS TO 12-17 LB-IN. (1.36-1.92 N.m).

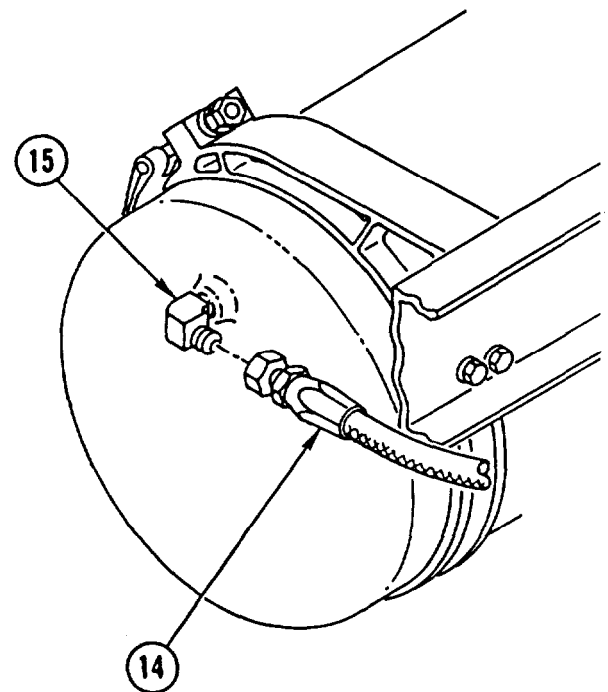
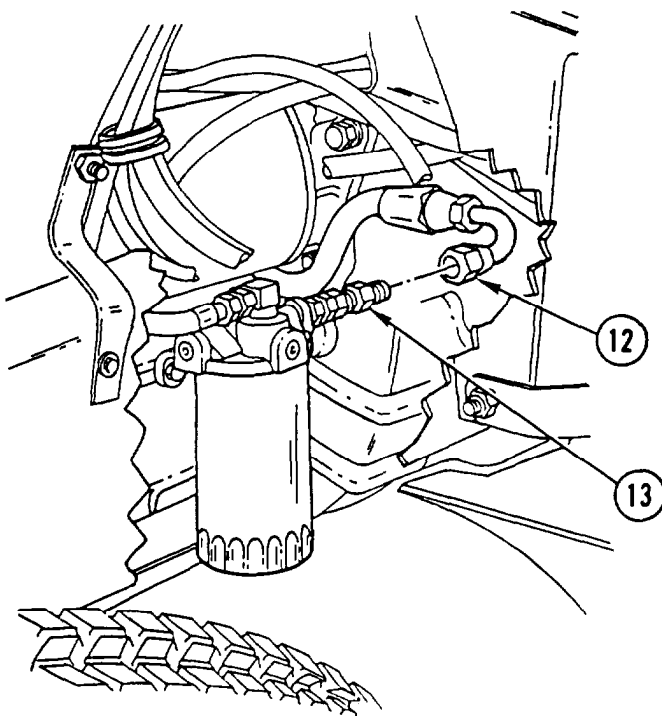

12. CONNECT FUEL SUPPLY HOSE (12) TO FUEL CHECK VALVE FITTING (13).
13. CONNECT FUEL RETURN LINE (14) TO VEHICLE FUEL RETURN LINE CONNECTION (15).
14. REPEAT STEPS 11 THRU 13 FOR REMAINING INJECTORS.

NOTE

Follow-on Maintenance:

- Install rocker arm assemblies (page 3-183).
- Prime fuel system (TM 9-2320-363-20).

INJECTOR SOLENOID REPAIR

This task covers: a. Disassembly b. Cleaning c. Inspection d. Repair e. Assembly

INITIAL SETUP

Tools and Special Equipment:

Shop Equipment, SC 4910-95-CL-A31
Tool Kit, SC 5180-90-CL-N05

Equipment Condition:

Reference	Condition Description
Page 3-108	Injector Removed

Materials/Parts:

Seal (2)	P/N 5234224
Plate, Load	P/N 5234878
Screw (4)	P/N 5234813
Retainer, Follower	P/N 5234867

DISASSEMBLY

1. REMOVE AND DISCARD FOUR SCREWS (1), LOAD PLATE (2), AND FOLLOWER RETAINER (3).
2. REMOVE SOLENOID (5).
3. REMOVE SPACER (6) AND TWO SEALS (7 AND 8). DISCARD SEALS.

CLEANING

Use general cleaning methods to clean all parts (page 2-30).

INSPECTION

Inspect all parts for wear or damage.

REPAIR

Use general repair methods to repair damaged parts (page 2-33).

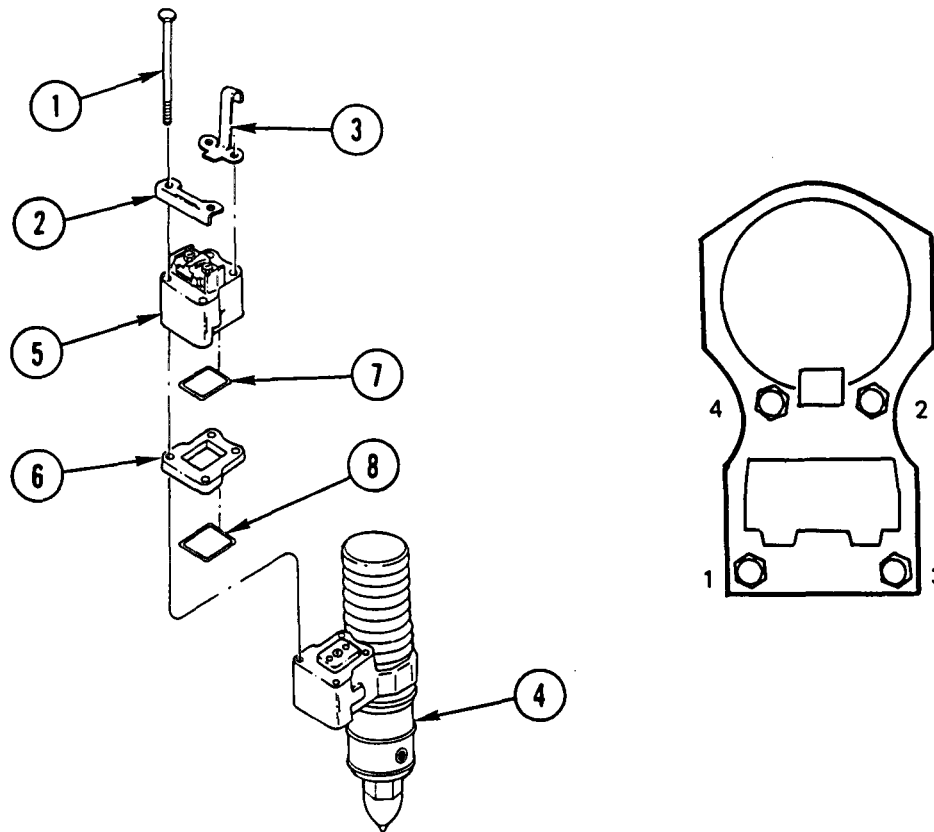

1. INSTALL NEW SEAL (8) ON SPACER (6) AND INSTALL ON INJECTOR BODY (4).
2. INSTALL NEW SEAL (7) ON SPACER (6).
3. INSTALL SOLENOID (5) ON TOP OF SEAL (7) AND SPACER (6).
4. ELECTRO-ETCH LAST FOUR NUMBERS OF INJECTOR ASSEMBLY PART NUMBER ON OUTSIDE FACE OF NEW LOAD PLATE (2).
5. INSTALL NEW FOLLOWER RETAINER (3), LOAD PLATE (2), AND FOUR NEW SCREWS (1).
6. TIGHTEN FOUR SCREWS TO 5 LB-IN. (0.6 N.m) IN SEQUENCE SHOWN.
7. TIGHTEN FOUR SCREWS AGAIN TO 20 LB-IN. (2.26 N.m) USING SAME SEQUENCE.

NOTE

Follow-on Maintenance:

Install injector (page 3-108).

GEAR CASE COVER REPLACEMENT

This task covers: a. Removal b. Cleaning c. Inspection d. Installation

INITIAL SETUP

Tools and Special Equipment:

Shop Equipment, SC 4910-95-CL-A31
 Tool Kit, SC 5180-90-CL-N05
 Guide Stud (2), J36107

Materials/Parts:

Ring, Seal P/N 5141452
 Eliminator, Appendix B, Item 18
 Gasket
 Oil, Lubricating Appendix B, Item 37

References:

TM 9-2320-363-20

Equipment Condition:

Reference	Condition Description
TM 9-2320-363-20	Alternator Removed
Page 7-2	Power Steering Pump Removed
TM 9-2320-363-20	Tachometer Drive Removed

Equipment Condition (Cont):

Reference	Condition Description
Page 3-126	Accessory Drive Removed
Page 3-92	Air Compressor Drive Removed
TM 9-2320-363-20	Water Pump Removed
Page 3-56	Fan Drive Support Removed
Page 3-220	Oil Pan Removed
Page 3-46	Front Engine Mount Adapter Removed

General Safety Instructions:

WARNING

- Gear case cover weighs 89 lb (40 kg). Attach suitable lifting device prior to removal or installation to prevent possible injury to personnel.
- Be careful not to slide gear case cover off guide studs. To do so could result in injury to personnel or equipment damage.

REMOVAL

CAUTION

Use wood blocks on jack stands to protect oil pan flange.

1. INSTALL JACK STAND UNDER EACH SIDE OF OIL PAN FLANGE. REMOVE PREVIOUSLY INSTALLED SUPPORT.

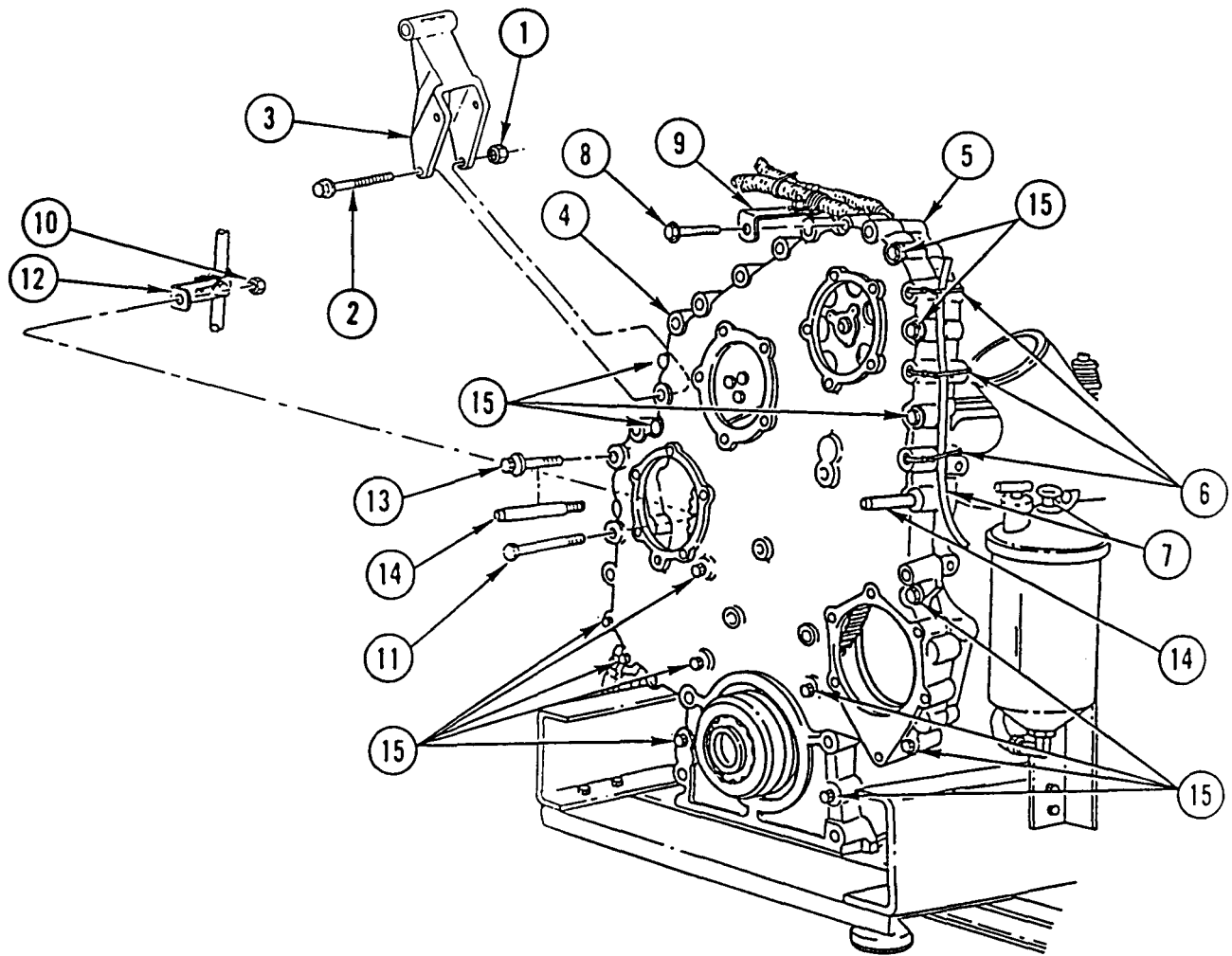

NOTE

Procedure may be accomplished in vehicle or on engine stand.

2. REMOVE TWO NUTS (1) AND TWO BOLTS (2) SECURING ALTERNATOR MOUNTING BRACKET (3) ON GEAR CASE COVER (4) AND GEAR HOUSING (5).

NOTE

Quantity of tie straps may vary. Discard as necessary.

3. REMOVE AND DISCARD TIE STRAPS (6) SECURING FAN CLUTCH SOLENOID AIR LINE (7) AND MOVE AIR LINE AWAY FROM GEAR CASE COVER (4) AND GEAR HOUSING (5).
4. REMOVE BOLT (8) FROM STANDOFF BRACKET (9) AND GEAR CASE COVER (4). MOVE STANDOFF BRACKET (9) AWAY FROM GEAR CASE COVER (4).
5. REMOVE NUT (10), BOLT (11), AND STANDOFF BRACKET (12) FROM GEAR CASE COVER (4). MOVE STANDOFF BRACKET (12) AWAY FROM GEAR CASE COVER (4).
6. REMOVE TWO BOLTS (13) FROM OPPOSITE SIDES OF GEAR CASE COVER (4). REPLACE TWO BOLTS (13) WITH TWO GUIDE STUDS (14).
7. REMOVE 14 BOLTS (15).

GEAR CASE COVER REPLACEMENT (CONT)

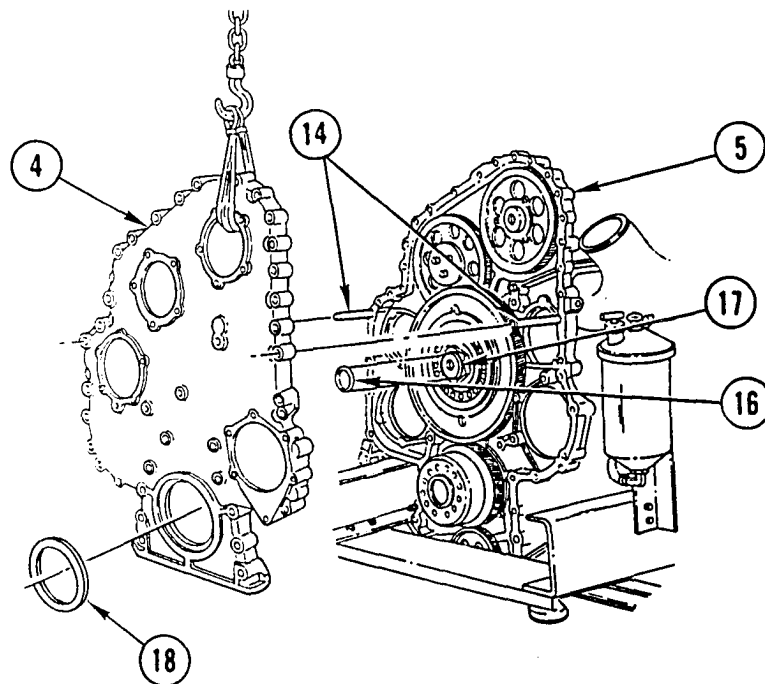

WARNING

Be careful not to slide gear case cover off guide studs. To do so could result in injury to personnel or equipment damage.

8. MOVE GEAR CASE COVER (4) AWAY FROM GEAR HOUSING (5) AND POSITION NYLON ROPE THRU TACHOMETER DRIVE COVER OPENING ON GEAR CASE COVER (4).

WARNING

Gear case cover weighs 89 lb (40 kg). Attach suitable lifting device prior to removal to prevent possible injury to personnel.

9. SECURE NYLON ROPE TO SUITABLE LIFTING DEVICE, SLIDE GEAR CASE COVER (4) OFF TWO GUIDE STUDS (14).
10. REMOVE AND DISCARD SEAL RING (16) BETWEEN BULL/IDLER GEAR HUB RECESS (17) AND GEAR CASE COVER (4).
11. REMOVE TWO GUIDE STUDS (14).
12. REMOVE ALL OLD GASKET ELIMINATOR FROM MATING SURFACES OF GEAR CASE COVER (4) AND GEAR HOUSING (5).
13. REMOVE FRONT OIL SEAL (18) FROM GEAR CASE COVER (4). DISCARD OIL SEAL.

CLEANING

Use general cleaning methods to clean all parts (page 2-30).

INSPECTION

1. INSPECT VISIBLE AREA OF CRANKSHAFT OIL SEAL CONTACT AREA CAREFULLY FOR DAMAGE WHENEVER GEAR CASE COVER IS REMOVED.
2. INSPECT ALL PARTS FOR WEAR OR DAMAGE.

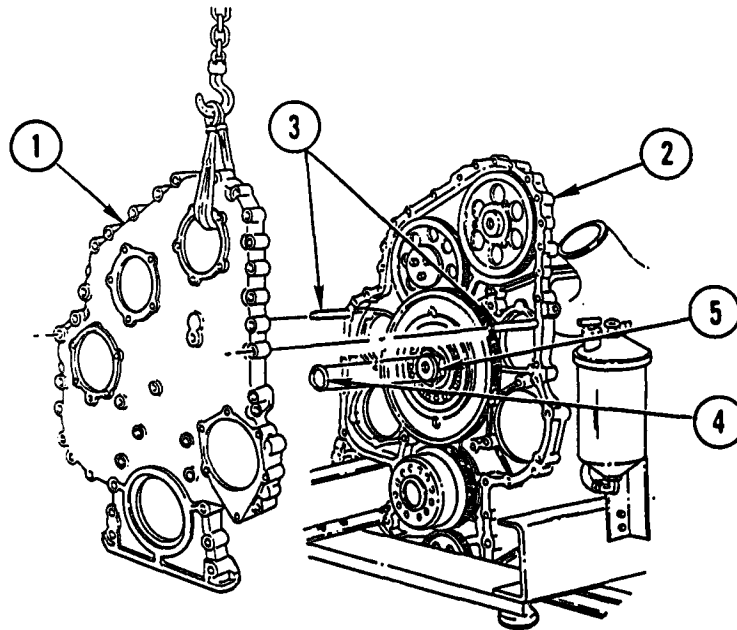
INSTALLATION**WARNING**

Gear case cover weighs 89 lb (40 kg). Attach suitable lifting device prior to installation to prevent possible injury to personnel.

1. POSITION NYLON ROPE THRU TACHOMETER DRIVE COVER OPENING OF GEAR CASE COVER (1) AND SECURE ROPE TO SUITABLE LIFTING DEVICE.

NOTE

Gasket eliminator cures in presence of air. Keep time to minimum between gear case cover installation and tightening gear case cover mounting bolts.

2. APPLY CONTINUOUS 1/16-IN. BEAD OF GASKET ELIMINATOR TO MATING SURFACES OF GEAR HOUSING (2).
3. INSTALL TWO GUIDE STUDS (3) IN BOLT HOLES ON OPPOSITE SIDES OF GEAR HOUSING (2).
4. INSTALL NEW SEAL RING (4) IN BULL/IDLER GEAR HUB RECESS (5) USING ENGINE LUBRICATING OIL TO HOLD SEAL RING IN PLACE.

GEAR CASE COVER REPLACEMENT (CONT)

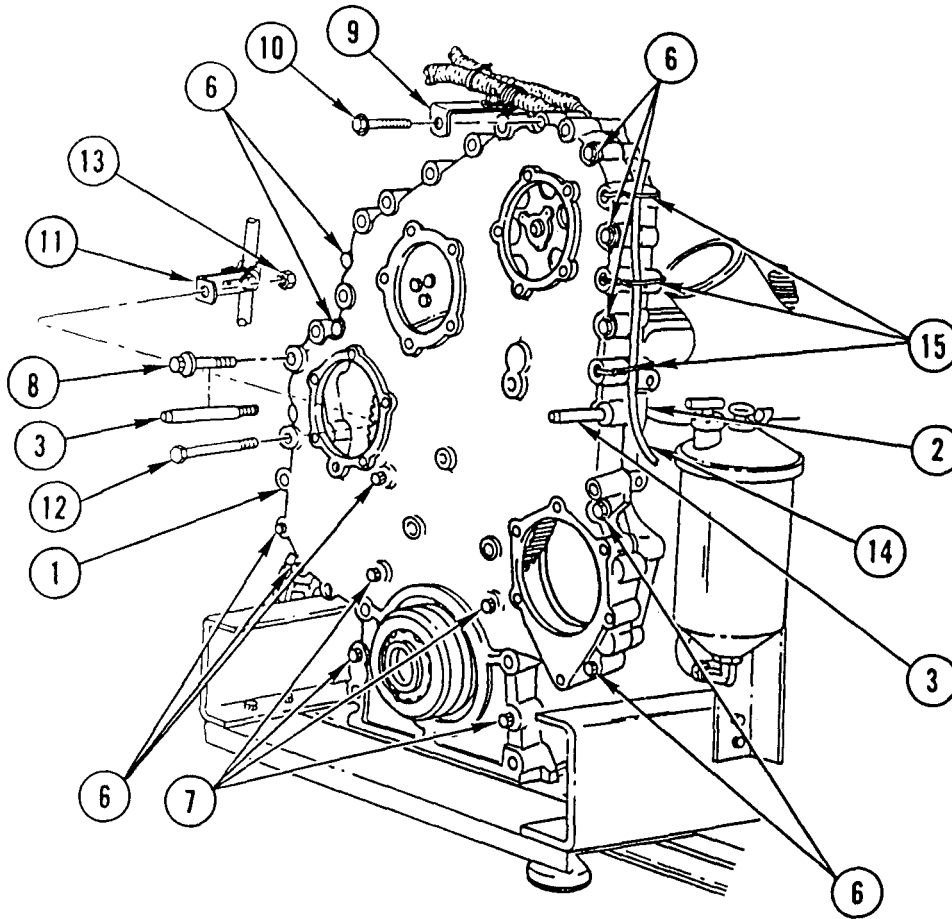

NOTE

Make sure guide studs are positioned in corresponding bolt holes of gear case cover and gear housing.

5. POSITION GEAR CASE COVER (1) ON TWO GUIDE STUDS (3) AND REMOVE NYLON ROPE AND LIFTING DEVICE.
6. INSTALL GEAR CASE COVER (1) AGAINST GEAR HOUSING (2).
7. INSTALL 10 SHORT BOLTS (6).
8. INSTALL FOUR LONG BOLTS (7).
9. REMOVE TWO GUIDE STUDS (3) AND INSTALL TWO BOLTS (8).
10. INSTALL STANDOFF BRACKET (9) AND BOLT (10) TO GEAR CASE COVER (1).
11. INSTALL STANDOFF BRACKET (11), BOLT (12), AND NUT (13) ON GEAR CASE COVER (1).
12. SECURE FAN CLUTCH SOLENOID AIR LINE (14) TO GEAR CASE COVER (1) AND GEAR HOUSING (2) WITH NEW TIE STRAPS (15).

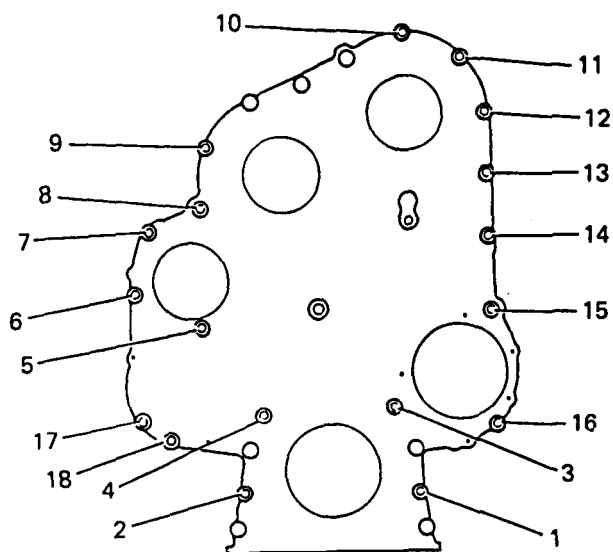

13. TIGHTEN BOLTS TO 43-54 LB-FT (58-73 N.m) IN SEQUENCE SHOWN.

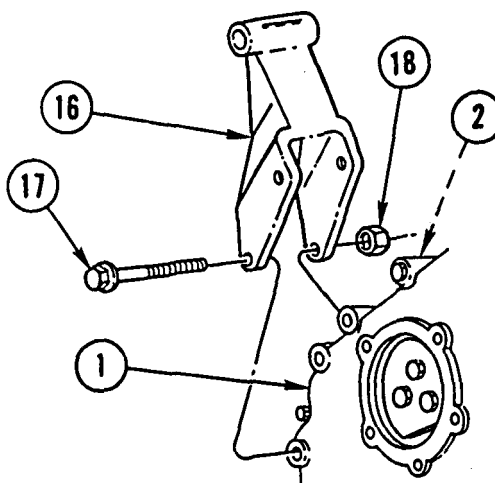

14. POSITION ALTERNATOR MOUNTING BRACKET (16) ON GEAR CASE COVER (1) AND GEAR HOUSING ASSEMBLY (2). INSTALL TWO BOLTS (17) AND TWO NUTS (18). HOLD TWO NUTS AND TIGHTEN TWO BOLTS TO 43-54 LB-FT (58-73 N.m).

NOTE

Follow-on Maintenance:

- Install crankshaft front oil seal (page 3-227 or 3-231).
- Install water pump (TM 9-2320-363-20).
- Install air compressor drive (page 3-92).
- Install accessory drive (page 3-126).
- Install tachometer drive (TM 9-2320-363-20).
- Install power steering pump (page 7-2).
- Install alternator (TM 9-2320-363-20).
- Install fan drive support (page 3-56).
- Install front engine mount adapter (page 3-46).
- Install oil pan (page 3-220).

VIBRATION DAMPER REPLACEMENT

This task covers: a. Removal b. Cleaning c. Inspection d. Installation

INITIAL SETUP

Tools and Special Equipment:

Shop Equipment, SC 4910-95-CL-A31
Tool Kit, SC 5180-90-CL-N05

Equipment Condition:

Reference	Condition Description
TM 9-2320-363-20	Fan Belt Removed

References:

TM 9-2320-363-20

REMOVAL

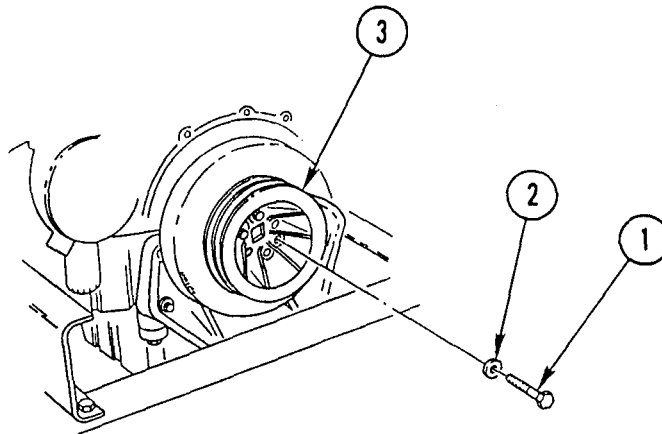

CAUTION

- Take care not to pry or drop vibration damper to prevent damage to equipment. Vibration damper must be replaced if chipped or damaged,
- Support pulley and damper during removal to prevent damage to equipment.

1. REMOVE SIX CRANKSHAFT PULLEY ATTACHING BOLTS (1) AND SIX WASHERS (2) FROM CRANKSHAFT PULLEY (3).

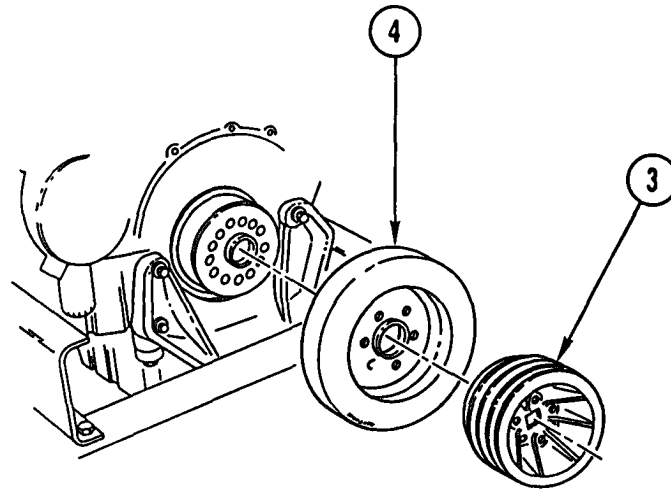

CAUTION

To prevent damage to equipment, do not pound or pry on vibration damper to aid in removal.

NOTE

Discard vibration damper at major engine overhaul or whenever engine requires crankshaft replacement.

2. REMOVE CRANKSHAFT PULLEY (3).
3. REMOVE VIBRATION DAMPER (4).

Use general cleaning methods to clean all parts (page 2-30).

1. INSPECT VIBRATION DAMPER FOR DENTS, GOUGES, FLUID LEAKS, OR BULGES. REPLACE VIBRATION DAMPER IF ANY OF THESE CONDITIONS ARE FOUND.
2. INSPECT CRANKSHAFT PULLEY FOR CRACKED, BROKEN, OR BENT FLANGES. REPLACE CRANKSHAFT PULLEY IF ANY OF THESE CONDITIONS ARE FOUND.
3. MAKE SURE CRANKSHAFT PULLEY AND VIBRATION DAMPER MATING SURFACES ARE CLEAN AND FREE OF DIRT OR DAMAGE.

VIBRATION DAMPER REPLACEMENT (CONT)

INSTALLATION

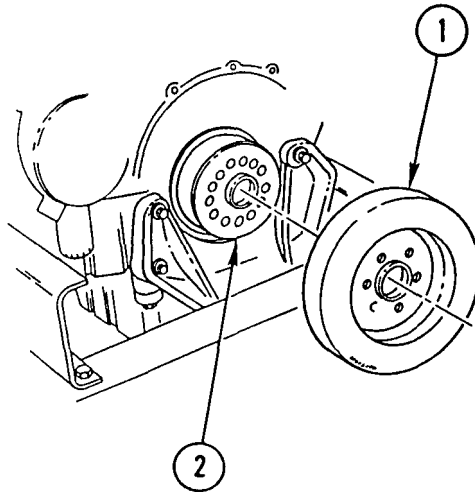

CAUTION

Support pulley and damper during installation to prevent damage to equipment.

NOTE

Part number stamped on vibration damper should face out (away from engine) when vibration damper is installed, Make sure mating surfaces of crankshaft pulley and vibration damper are clean and free of dirt or damage.

1. INSTALL VIBRATION DAMPER (1) AGAINST CRANKSHAFT BUTT (2) AND SEAT FIRMLY.

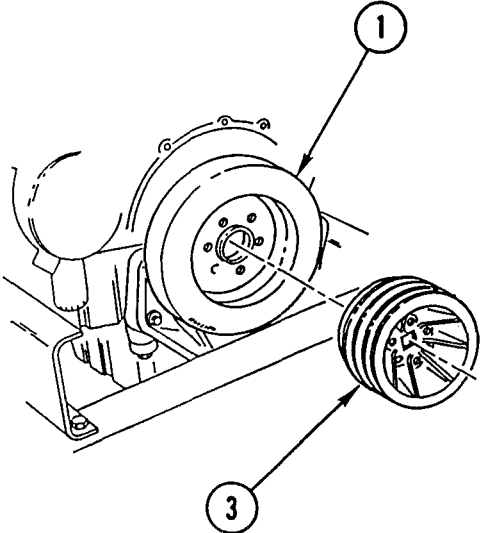

2. INSTALL CRANKSHAFT PULLEY (3) AND SEAT FIRMLY AGAINST VIBRATION DAMPER (1).

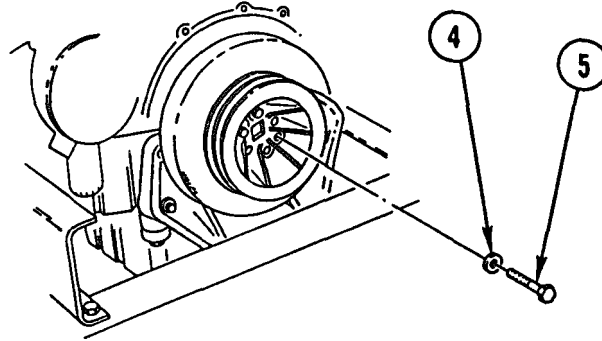

3. INSTALL SIX WASHERS (4) AND SIX CRANKSHAFT PULLEY ATTACHING BOLTS (5) HAND-TIGHT.
4. TIGHTEN SIX CRANKWAFT PULLEY ATTACHING BOLTS (5) TO 134-155 LB-FT (182-210 N.m).

NOTE

Follow-on Maintenance:
Install fan belt (TM 9-2320-363-20).

ACCESSORY DRIVE REPLACEMENT

This task covers: a. Removal b. Cleaning c. Inspection d. Installation

INITIAL SETUP

Tools and Special Equipment:

Shop Equipment, SC 4910-95-CL-A31
 Tool Kit, SC 5180-90-CL-N05

Materials/Parts:

Ring, Seal	P/N 8929253
Oil, Lubricating	Appendix B, Item 37

References:

TM 9-2320-363-20

Equipment Condition:

Reference	Condition Description
TM 9-2320-363-20	Alternator Belt Removed

REMOVAL

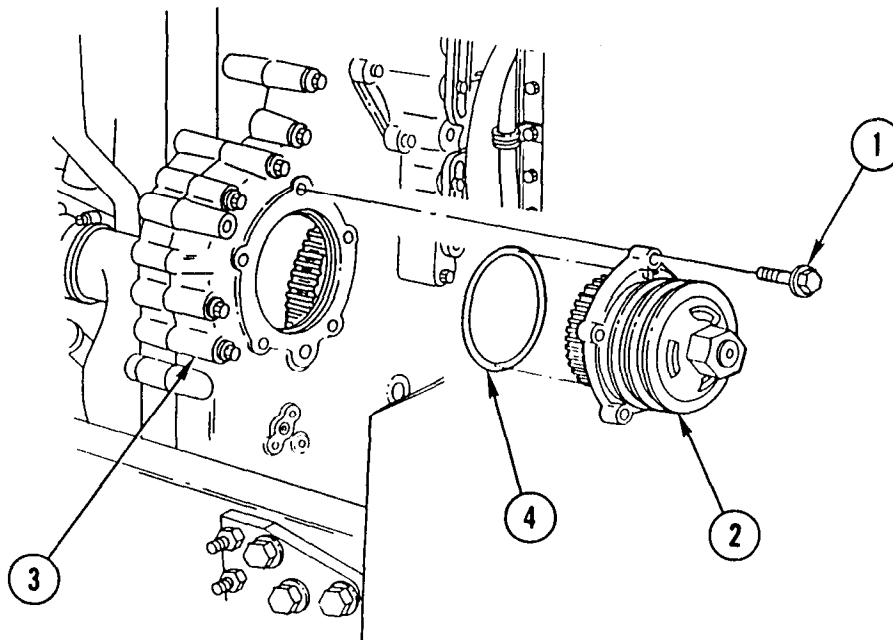

NOTE

If necessary, tap accessory drive with soft-nosed mallet to aid in removal.

1. REMOVE FIVE BOLTS (1) AND ACCESSORY DRIVE (2) FROM GEAR CASE COVER (3).
2. REMOVE AND DISCARD SEAL RING (4) FROM ACCESSORY DRIVE (2).

CLEANING

Use general cleaning methods to clean all parts (page 2-30).

INSPECTION

Inspect all parts for wear or damage.

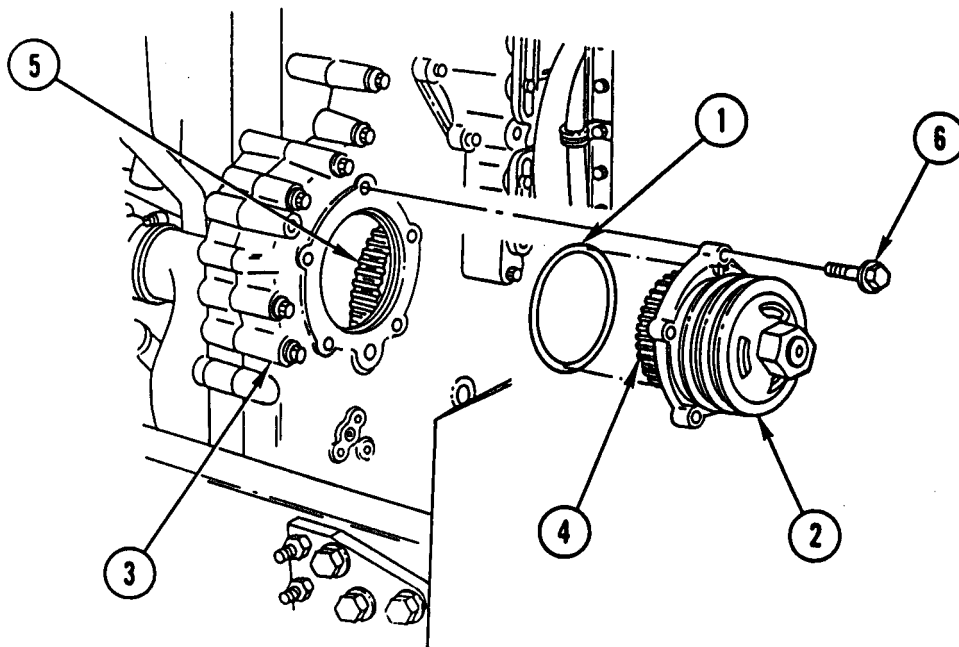
INSTALLATION

1. LUBRICATE NEW SEAL RING (1) WITH CLEAN ENGINE LUBRICATING OIL AND INSTALL SEAL RING (1) IN GROOVE ON ACCESSORY DRIVE (2).

NOTE

Install accessory drive with word UP cast into housing in 12 o'clock position.

2. INSTALL ACCESSORY DRIVE (2) ON GEAR CASE COVER (3) ENGAGING ACCESSORY DRIVE GEAR (4) WITH BULL GEAR (5).
3. ALINE BOLT HOLES OF ACCESSORY DRIVE (2) AND GEAR CASE COVER (3). PRESS ACCESSORY DRIVE (2) INTO PLACE AND INSTALL FIVE BOLTS (6).

ACCESSORY DRIVE REPLACEMENT (CONT)

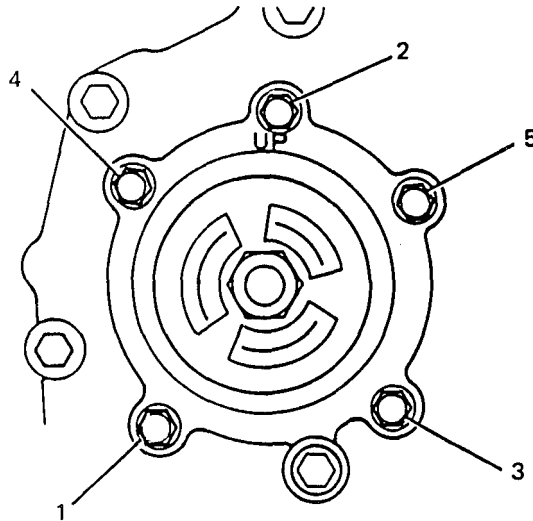

4. TIGHTEN FIVE BOLTS TO 22-28 LB-FT (30-38 N.m) IN PATTERN SHOWN.

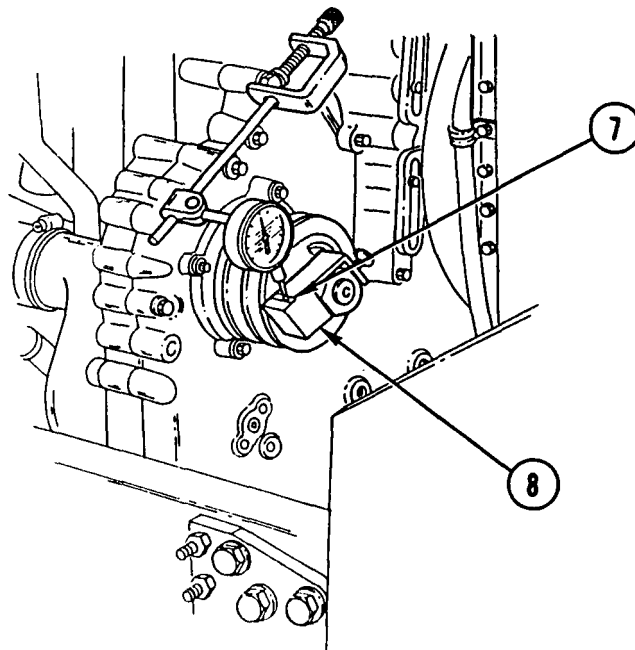

5. USE DIAL INDICATOR WITH CLAMP BASE TO MEASURE GEAR LASH BETWEEN ACCESSORY DRIVE GEAR AND BULL GEAR. POSITION DIAL INDICATOR TO READ BETWEEN SCRIBED LINES (7) ON GEAR LASH CHECKER (8). GEAR LASH SHOULD BE 0.001-0.010 IN. (0.025-0.254 mm). IF GEAR LASH DOES NOT MEET SPECIFICATIONS, ACCESSORY DRIVE MUST BE REPLACED.

NOTE

Follow-on Maintenance:
Install alternator belt (TM 9-2320-363-20).

ENGINE RETARDER REPLACEMENT AND REPAIR

This task covers: a. Removal b. Disassembly c. Cleaning d. Inspection e. Repair f. Assembly
g. Installation h. Adjustment

INITIAL SETUP

Tools and Special Equipment:

Shop Equipment, SC 4910-95-CL-A31
Tool Kit, SC 5180-90-CL-N05

Materials/Parts:

Ring, Seal	P/N 001081
Ring, Seal	P/N 001082
Ring, Seal	P/N 001083
Ring, Retaining (2)	P/N 012991
Toweling, Paper	Appendix B, Item 63
Oil, Lubricating	Appendix B, Item 37
Towel, Shop	Appendix B, Item 62
International Compound No. 2	Appendix B, Item 29

Personnel Required: (2)

Equipment Condition:

Reference	Condition Description
TM 9-2320-363-20	Batteries Disconnected
Page 3-71	Rocker Cover Removed

General Safety Instructions:

<p>WARNING</p> <ul style="list-style-type: none"> • Parts are under spring tension. Release tension slowly to prevent personal injury. • To prevent injury when blowing oil from bolt holes, wear adequate protective clothing.
--

ENGINE RETARDER REPLACEMENT AND REPAIR (CONT)

REMOVAL

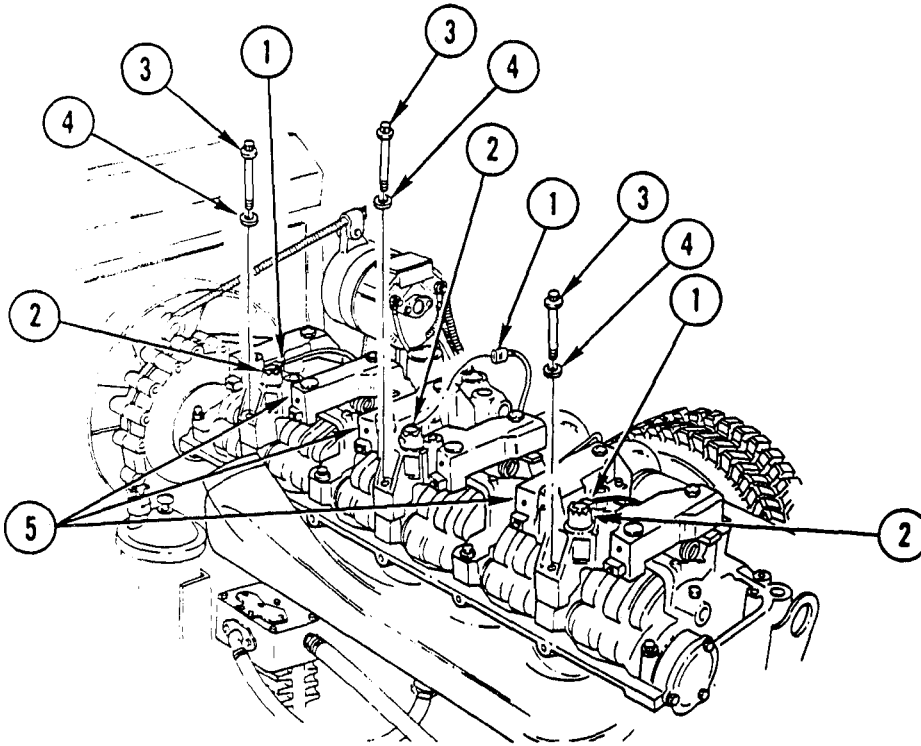

CAUTION

Grasp connectors when removing wiring harness solenoid connectors from terminal. Do not pull on wires to prevent damage to equipment.

1. DISCONNECT THREE WIRING HARNESS SOLENOID CONNECTORS (1) FROM THREE SOLENOID VALVES (2).
2. REMOVE THREE BOLTS (3) AND THREE WASHERS (4) FROM THREE ENGINE RETARDERS (5).

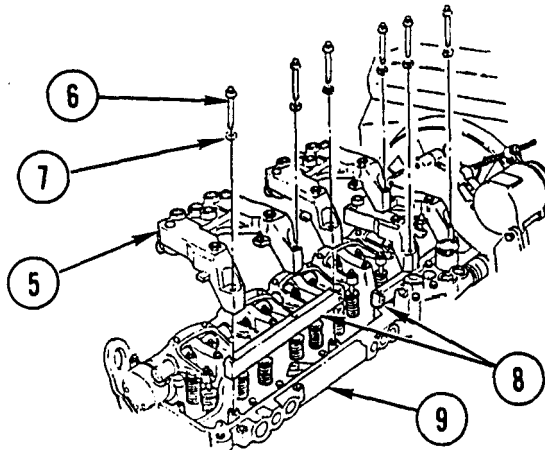

CAUTION
 Tag each engine retarder to aid in installation. Do not mix engine retarders.

3. REMOVE SIX BOLTS (6), SIX WASHERS (7), THREE ENGINE RETARDERS (5), AND TWO SPACER BARS (8) FROM CYLINDER HEAD (9).

DISASSEMBLY

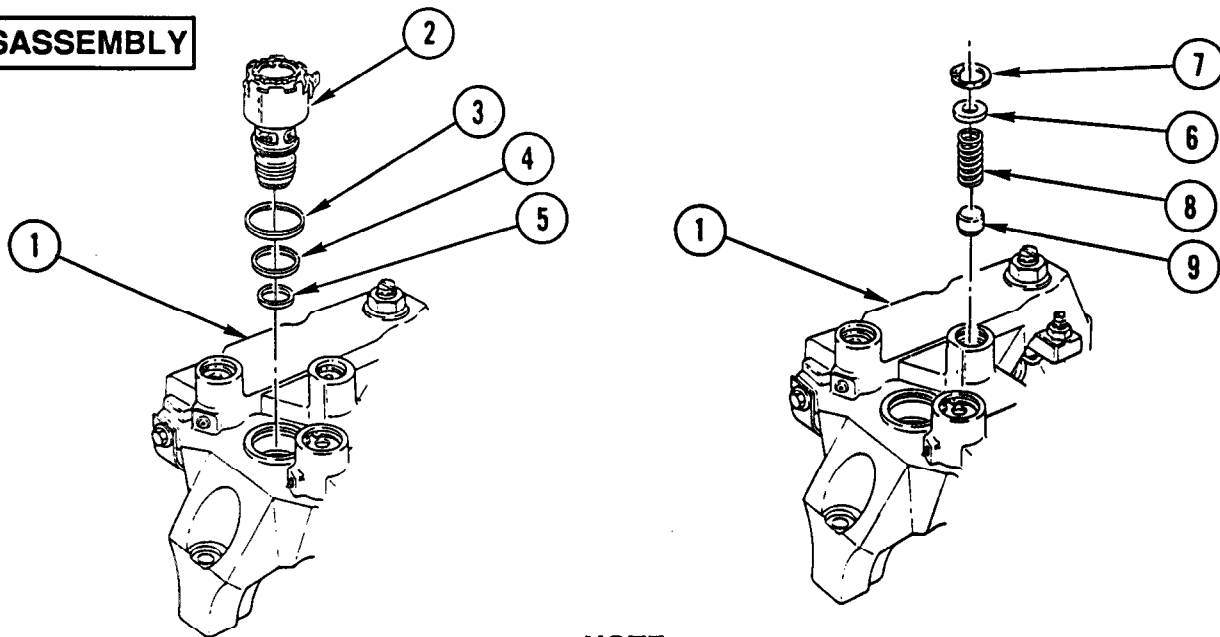

NOTE

Procedure is the same for all three engine retarder housings.

1. PLACE ENGINE RETARDER HOUSING (1) ON BENCH.

CAUTION
 Do not disassemble or tamper with solenoid valve. Engine damage could result.

2. UNSCREW SOLENOID VALVE (2) WITH 12-POINT SOCKET.
3. REMOVE AND DISCARD THREE SEAL RINGS (3, 4, AND 5). IF SEAL RING (5) STAYS IN BOTTOM OF ENGINE RETARDER HOUSING (1), REMOVE SEAL RING (5) WITH WIRE.

WARNING
 Parts are under spring tension. Release tension slowly to prevent personal injury.

4. PRESS DOWN ON WASHER (6) AND REMOVE RETAINING RING (7). DISCARD RETAINING RING.
5. REMOVE WASHER (6) AND SPRING (8).
6. USING MAGNET, REMOVE ACCUMULATOR PISTON (9) FROM ENGINE RETARDER HOUSING (1).

ENGINE RETARDER REPLACEMENT AND REPAIR (CONT)

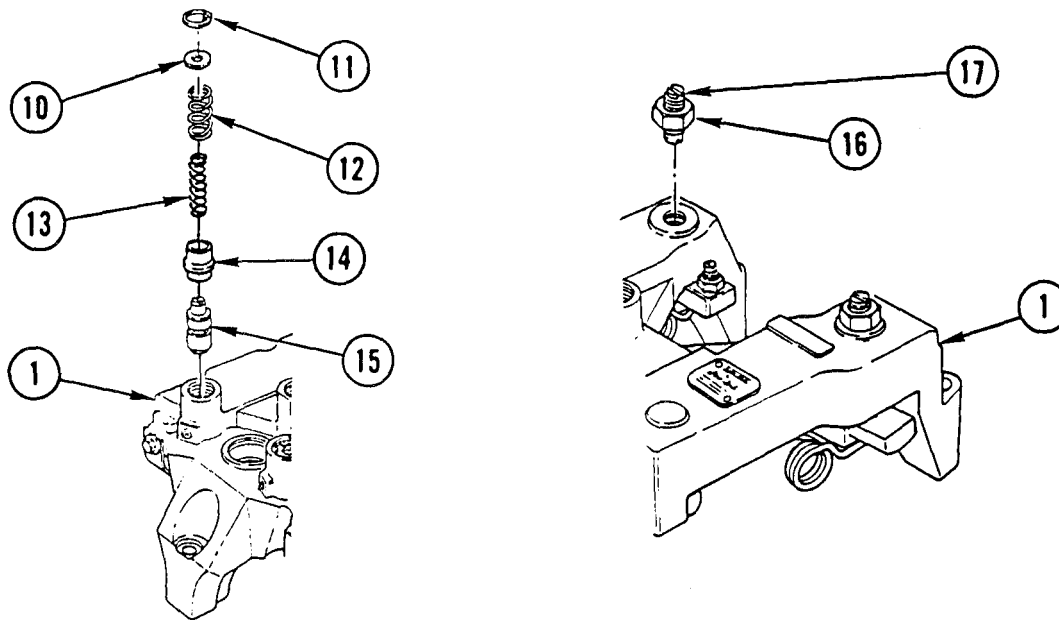

NOTE

Steps 7 thru 15 are for right side of engine retarder housing. Repeat steps 7 thru 15 for left side.

7. PRESS DOWN ON WASHER (10) AND REMOVE RETAINING RING (11). DISCARD RETAINING RING.
8. REMOVE WASHER (10), SPRING (12), SPRING (13), AND COLLAR (14).
9. REMOVE CONTROL VALVE (15) FROM ENGINE RETARDER HOUSING (1).
10. LOOSEN LOCK NUT (16) AND REMOVE ADJUSTING SCREW (17) FROM ENGINE RETARDER HOUSING (1).

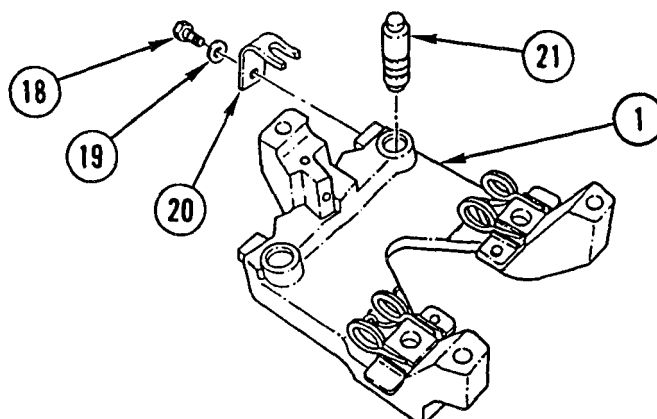

11. TURN ENGINE RETARDER HOUSING (1) OVER.
12. REMOVE CAPSCREW (18), WASHER (19), AND FLAT SPRING (20) FROM ENGINE RETARDER HOUSING (1).
13. REMOVE MASTER PISTON (21) FROM ENGINE RETARDER HOUSING (1).

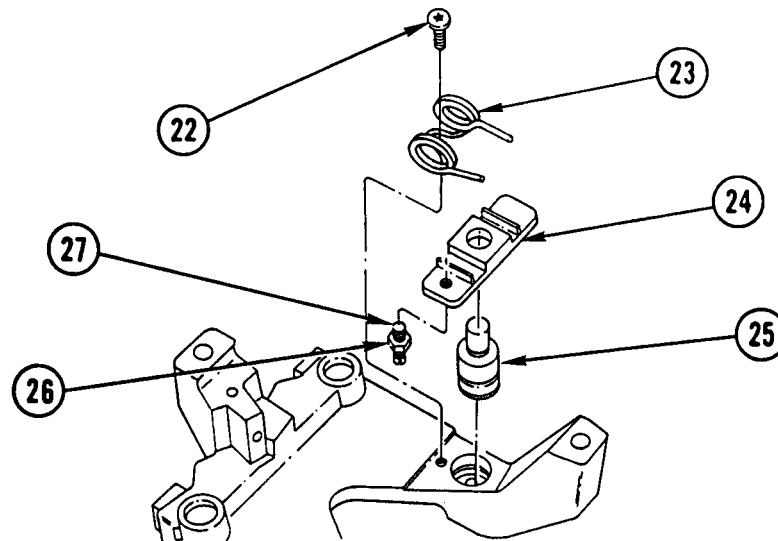

14. REMOVE SCREW (22), TORSION SPRING (23), SLAVE PISTON BRIDGE (24), AND SLAVE PISTON (25).
15. LOOSEN LOCK NUT (26) AND REMOVE ADJUSTING SCREW (27) FROM SLAVE PISTON BRIDGE (24).

CAUTION

Do not use rags that may leave lint and residue which can plug oil passageways.

1. USE GENERAL CLEANING METHODS TO CLEAN ALL PARTS (PAGE 2-30).
2. USING CLEAN PAPER TOWELING, CLEAN ENGINE RETARDER HOUSING BORES. DIP CONTROL VALVES AND PISTONS IN CLEAN ENGINE LUBRICATING OIL.

ENGINE RETARDER REPLACEMENT AND REPAIR (CONT)

INSPECTION

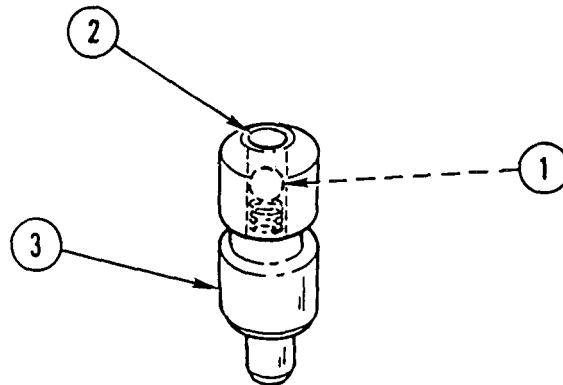

1. VERIFY BALL (1) MOVES FREELY BY PUSHING WIRE THRU HOLE (2) IN BASE OF CONTROL VALVE (3). LIGHT PRESSURE ON WIRE SHOULD MOVE BALL (1). BALL SHOULD RETURN WHEN PRESSURE IS RELEASED.

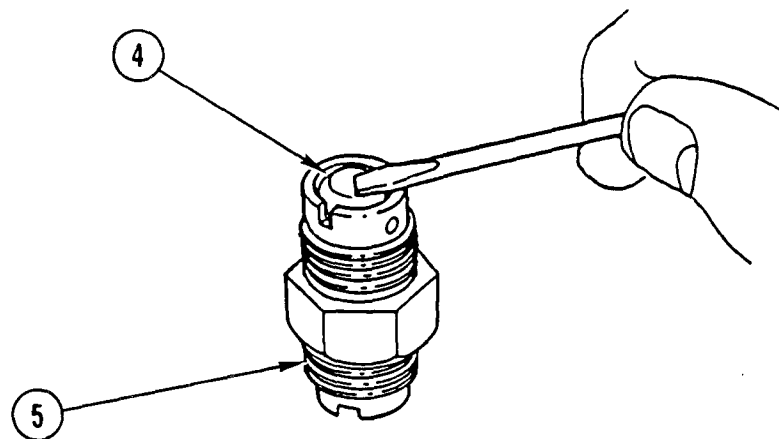

2. MAKE SURE PLUNGER (4) PROTRUDES FROM BOTTOM OF ADJUSTING SCREW (5).
3. MAKE SURE PLUNGER (4) HAS LIGHT SPRING PRESSURE WHEN PRESSED AND MOVES FREELY.
4. INSPECT ALL PARTS FOR WEAR OR DAMAGE.

REPAIR

1. IF DEFECTIVE, REPLACE ENTIRE ADJUSTING SCREW AND LOCK NUT.
2. USE GENERAL REPAIR METHODS TO REPAIR DAMAGED PARTS (PAGE 2-33).

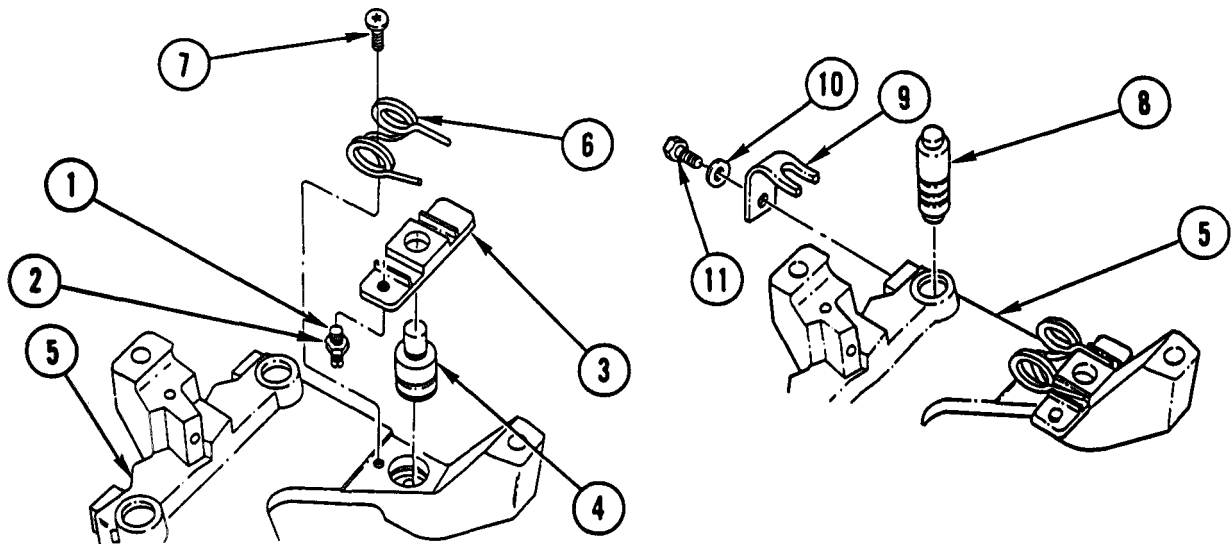
ASSEMBLY**NOTE**

- Procedure is the same for all three engine retarder housings.
- Steps 1 thru 12 are for right side of engine retarder housing. Repeat steps 1 thru 12 for left side.

1. INSTALL ADJUSTING SCREW (1) AND LOCK NUT (2) IN SLAVE PISTON BRIDGE (3).
2. INSTALL SLAVE PISTON (4) IN ENGINE RETARDER HOUSING (5).

NOTE

Locate part number on slave piston bridge away from engine retarder housing.

3. INSTALL SLAVE PISTON BRIDGE (3) WITH ADJUSTING SCREW (1) TOWARD CENTER OF ENGINE RETARDER HOUSING (5).
4. INSTALL TORSION SPRING (6) WITH ENDS OVER SLAVE PISTON BRIDGE (3).
5. INSTALL SCREW (7) OVER CENTER PART OF TORSION SPRING (6) ON ENGINE RETARDER HOUSING (5). TIGHTEN SCREW TO 180 LB-IN. (20 N.m).

NOTE

Make sure flat spring legs are centered around master piston boss.

6. INSTALL MASTER PISTON (8), FLAT SPRING (9), WASHER (10), AND CAPSCREW (11) IN ENGINE RETARDER HOUSING (5). TIGHTEN CAPSCREW TO 100 LB-IN. (10 N.m).

ENGINE RETARDER REPLACEMENT AND REPAIR (CONT)

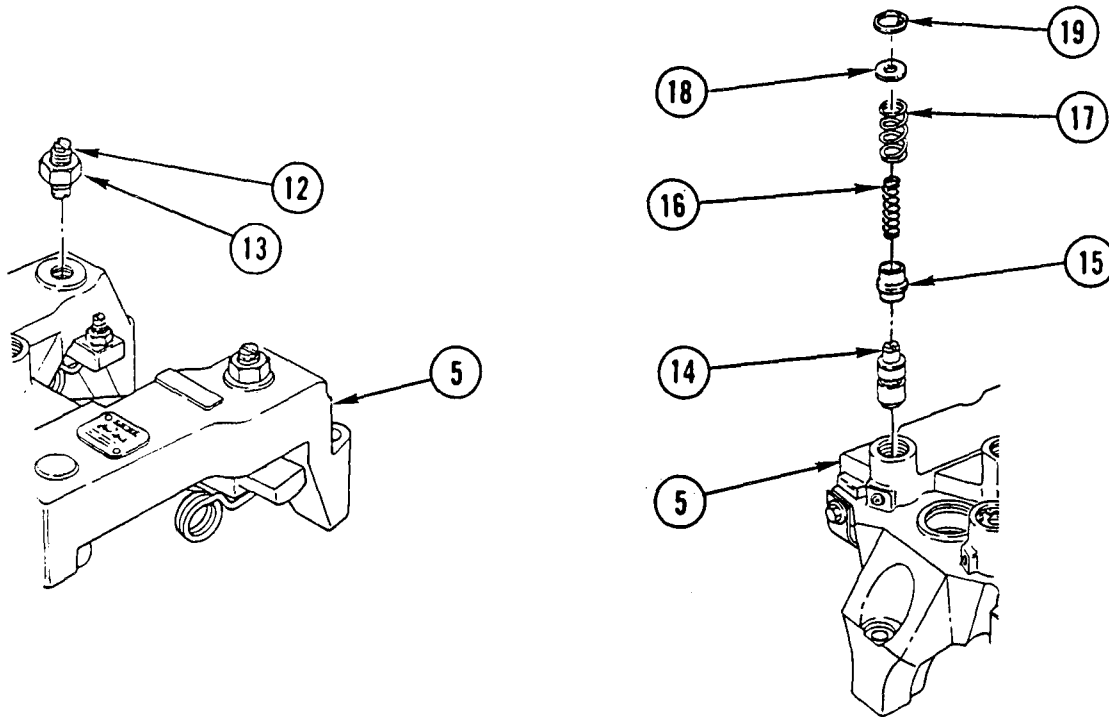

7. TURN ENGINE RETARDER HOUSING (5) OVER.
8. INSTALL ADJUSTING SCREW (12) AND LOCK NUT (13) IN ENGINE RETARDER HOUSING (5)
9. HOLD CONTROL VALVE (14) BY STEM AND DROP VALVE (14) INTO ENGINE RETARDER HOUSING (5). IF BINDING OCCURS OR IF BALL IS STUCK IN CONTROL VALVE (14), REPLACE CONTROL VALVE.
10. INSTALL COLLAR (15) IN ENGINE RETARDER HOUSING (5) WITH LONG SLEEVE AREA UP.
11. INSTALL SPRING (16) IN CENTER OF COLLAR (15) AND INSTALL SPRING (17) OVER TOP OF COLLAR (15).
12. PRESS WASHER (18) TO COMPRESS SPRINGS (16 AND 17). INSTALL NEW RETAINING RING (19). ROTATE RETAINING RING (19) 90 DEGREES TO ENSURE PROPER SEATING IN GROOVE.

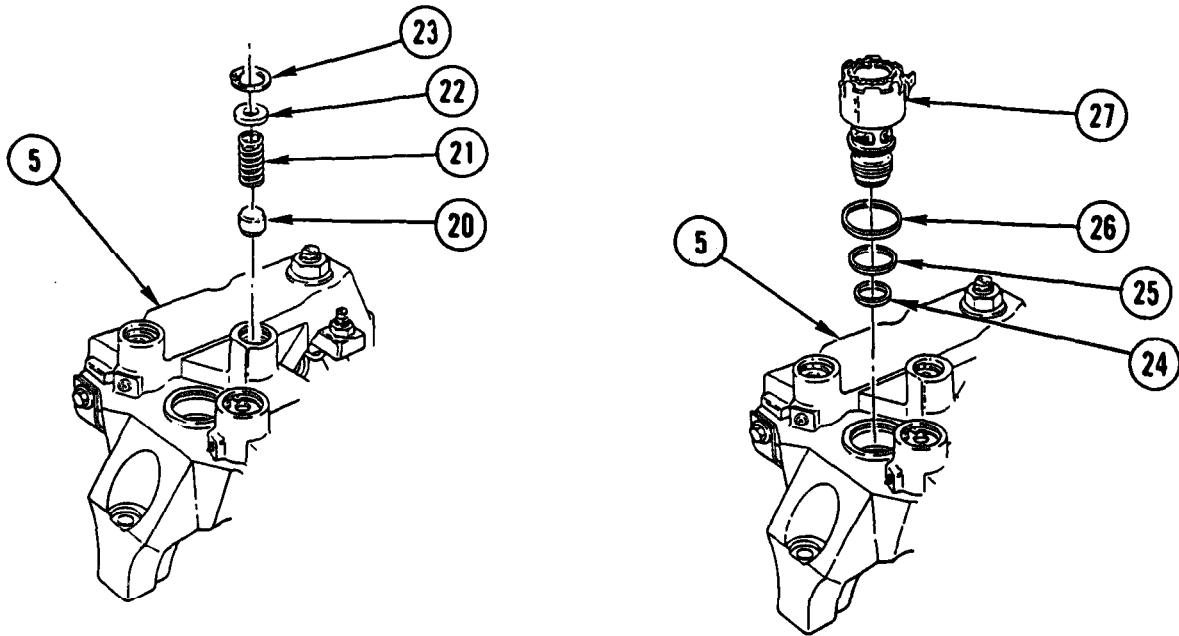

13. INSTALL ACCUMULATOR PISTON (20), SPRING (21), AND WASHER (22) IN ENGINE RETARDER HOUSING (5).
14. PRESS WASHER (22) TO COMPRESS SPRING (21) AND INSTALL NEW RETAINING RING (23). ROTATE RETAINING RING (23) 90 DEGREES TO ENSURE PROPER SEATING IN GROOVE.

CAUTION

Be careful not to twist seal rings while installing to prevent damage to equipment.

15. COAT THREE NEW SEAL RINGS (24, 25, AND 26) WITH CLEAN ENGINE LUBRICATING OIL. INSTALL SEAL RINGS (26 AND 25) ON SOLENOID VALVE (27).
16. INSTALL SEAL RING (24) IN BOTTOM ENGINE RETARDER HOUSING (5).
17. THREAD SOLENOID VALVE (27) INTO ENGINE RETARDER HOUSING (5). TIGHTEN SOLENOID VALVE TO 60 LB-IN. (7 N.m).

ENGINE RETARDER REPLACEMENT AND REPAIR (CONT)

INSTALLATION

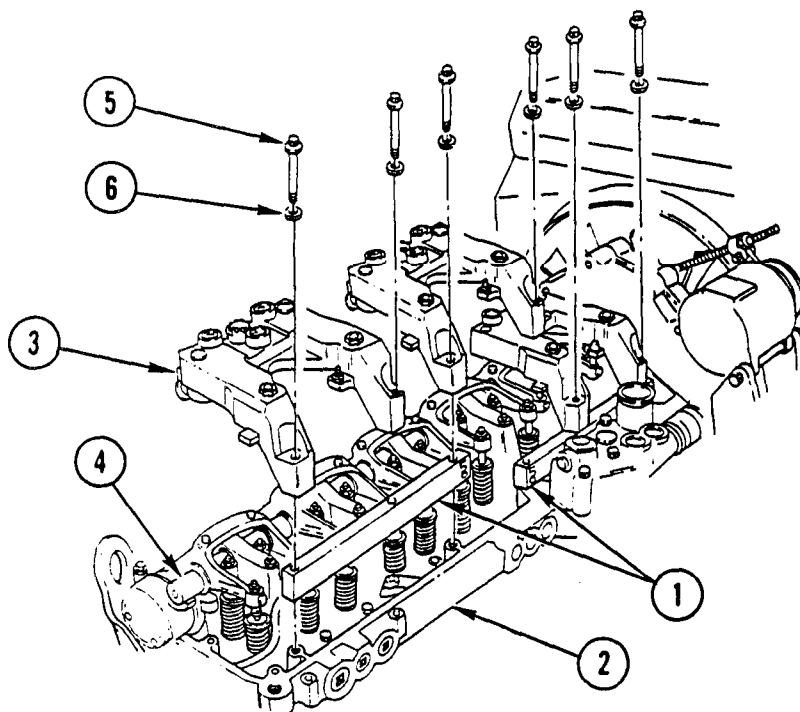

WARNING

To prevent injury when blowing oil from bolt holes, wear adequate protective clothing.

CAUTION

Make sure oil is removed from bolt holes to prevent engine block from cracking when tightening bolts.

1. COVER BOLT HOLES WITH SHOP TOWELS TO MINIMIZE OIL SPRAY.
2. ATTACH TUBING TO BLOW GUN NOZZLE AND BLOW OIL OUT OF BOLT HOLES.

NOTE

Position word OUT, stamped on each spacer bar, toward mid-engine, facing outside of engine.

3. POSITION TWO SPACER BARS (1) ON EXHAUST MANIFOLD SIDE OF CYLINDER HEAD (2), ALINE BOLT HOLES IN SPACER BARS (1) WITH ENGINE RETARDER BOLT HOLES IN CYLINDER HEAD (2).

CAUTION

Make sure engine retarder housings do not interfere with wiring harness to prevent damage to equipment.

4. INSTALL THREE ENGINE RETARDER HOUSINGS (3) OVER ROCKER SHAFTS (4).

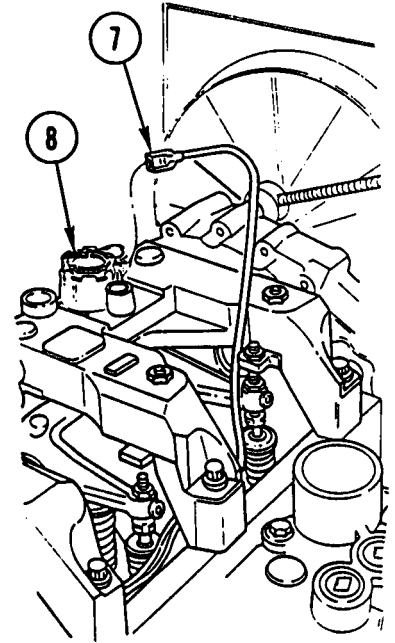
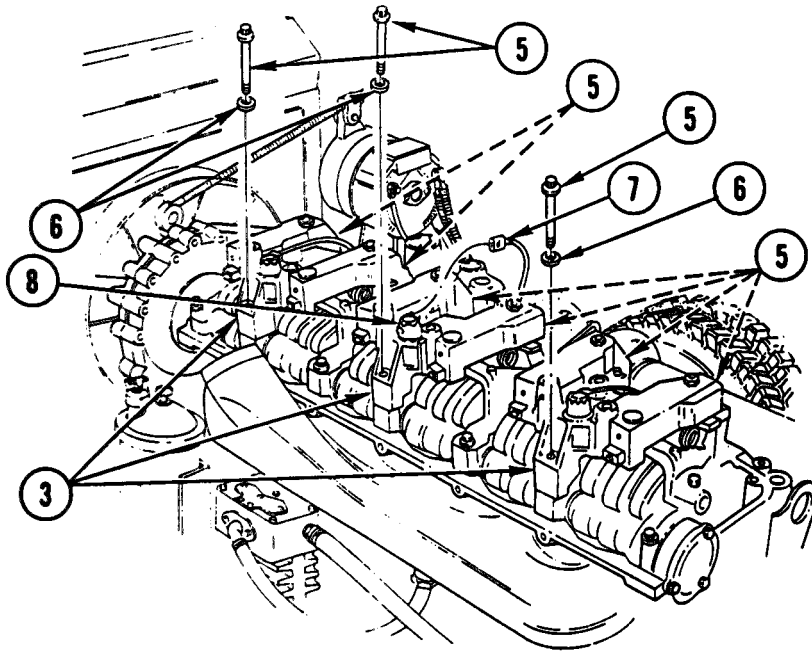

5. APPLY INTERNATIONAL COMPOUND NO. 2 TO THREADS AND UNDERSIDES OF HEADS OF NINE BOLTS (5).

CAUTION

Make sure wires are away from moving parts to prevent possible movement and contact with valve springs.

6. INSTALL NINE BOLTS (5) AND NINE WASHERS (6) IN ENGINE RETARDER HOUSING (3). TIGHTEN BOLTS TO 40 LB-FT (55 N.m).
7. REPEAT TIGHTENING OF NINE BOLTS (5) TO ENSURE ALL BOLTS ARE TIGHTENED TO TORQUE VALUE OF 80 LB-FT (110 N.m.).
8. CONNECT THREE WIRING HARNESS SOLENOID CONNECTORS (7) TO THREE SOLENOID VALVES (8).

ENGINE RETARDER REPLACEMENT AND REPAIR (CONT)

ADJUSTMENT

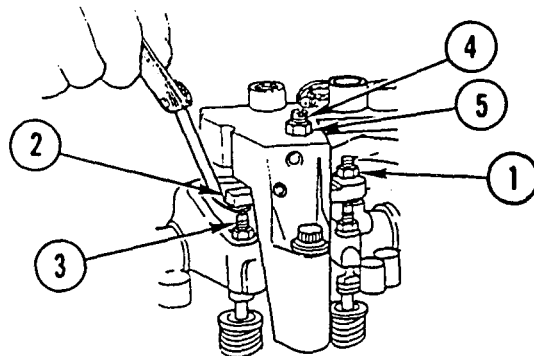

CAUTION

- Failure to use slave piston adjustment procedure will cause poor engine brake performance and/or serious engine damage.
- It is necessary to rotate engine to put exhaust valves in closed position for each cylinder being adjusted. Make sure proper engine valve lash has been obtained to prevent damage to equipment.

1. BACK OUT ADJUSTING SCREW (1) IN SLAVE PISTON BRIDGE (2) UNTIL END OF ADJUSTING SCREW (1) IS FLUSH WITH BOTTOM SURFACE OF SLAVE PISTON BRIDGE (2).
2. PLACE 0.02 IN. (0.5 mm) FEELER GAGE BETWEEN SOLID SIDE OF SLAVE PISTON BRIDGE (2) AND EXHAUST ROCKER ARM ADJUSTING SCREW (3).
3. TURN ADJUSTING SCREW (4) CLOCKWISE UNTIL LIGHT DRAG IS FELT ON FEELER GAGE.
4. HOLD ADJUSTING SCREW (4) IN POSITION AND REMOVE FEELER GAGE.
5. TIGHTEN LOCK NUT (5) TO 26 LB-FT (35 N.m).
6. USING FEELER GAGE, SET 0.02 IN. (0.5 mm) CLEARANCE BETWEEN ADJUSTING SCREW (1) AND ROCKER ARM ADJUSTING SCREW (6).
7. TURN ADJUSTING SCREW (1) CLOCKWISE UNTIL LIGHT DRAG IS FELT ON FEELER GAGE.
8. HOLD ADJUSTING SCREW (1) IN POSITION AND REMOVE FEELER GAGE.
9. TIGHTEN LOCK NUT (7) TO 26 LB-FT (35 N.m).
10. REPEAT STEPS 1 THRU 9 FOR REMAINING CYLINDERS.

NOTE

Follow-on Maintenance:
Install rocker cover (page 3-71).
Connect batteries (TM 9-2320-363-20).

CRANKSHAFT REAR OIL SEAL REPLACEMENT

This task covers: a. Removal b. Inspection c. Installation

INITIAL SETUP
Tools and Special Equipment:

Shop Equipment, SC 4910-95-CL-A31
 Tool Kit, SC 5180-90-CL-N05
 Oil Seal Remover, J35993
 Oil Seal Expander, J35685-A
 Oil Seal Installer, J35686

Materials/Parts:

Seal P/N 8929750
 Oil, Lubricating Appendix B, Item 37
 Cloth, Abrasive Appendix B, Item 10

Equipment Condition:

Reference	Condition Description
Page 3-154	Flex Plate Removed

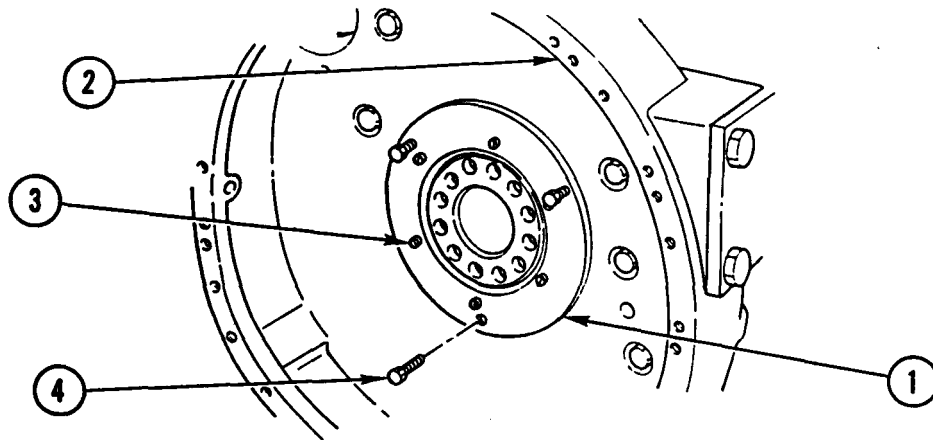
REMOVAL

NOTE

If oil seal remover screws strip out of oil seal casing, remove screws and bolts. Rotate oil seal remover 1/2 the distance between existing screw holes in seal casing and repeat steps 1 thru 4.

1. POSITION OIL SEAL REMOVER (1) OVER REAR OF CRANKSHAFT AGAINST FLYWHEEL HOUSING (2).

NOTE

Oil seal remover screws must be evenly snug against oil seal remover but not overtightened and stripped in oil seal casing.

2. INSTALL SIX OIL SEAL REMOVER SCREWS (3) THRU INNER CIRCLE OF HOLES IN OIL SEAL REMOVER (1) AND INTO OIL SEAL CASING.
3. THREAD THREE BOLTS (4) INTO OUTER CIRCLE OF HOLES IN OIL SEAL REMOVER (1) UNTIL BOLTS CONTACT FLYWHEEL HOUSING (2).
4. WORKING CLOCKWISE, TURN EACH BOLT (4) ONE FULL TURN UNTIL CRANKSHAFT REAR OIL SEAL IS REMOVED.

CRANKSHAFT REAR OIL SEAL REPLACEMENT (CONT)

INSPECTION

NOTE

Minor wear line on crankshaft surface should be evident where contact was made with oil seal. This is normal.

1. INSPECT OIL SEAL CONTACT SURFACE OF CRANKSHAFT CAREFULLY.
2. INSPECT EXPOSED AREA OF CRANKSHAFT FOR DIRT, BURRS, OR ROUGH SURFACES.
3. IF NECESSARY, CLEAN/SMOOTH CRANKSHAFT SURFACE WITH ABRASIVE CLOTH.

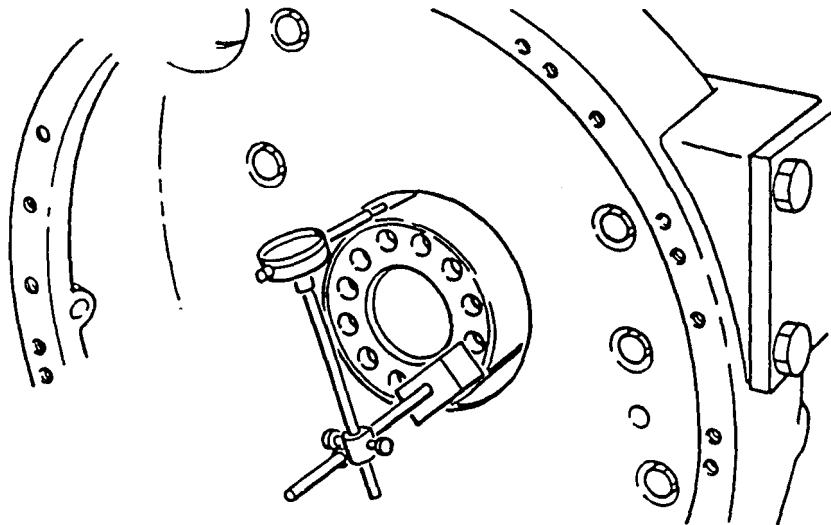

4. MAXIMUM RUNOUT OF OIL SEAL BORE IN FLYWHEEL HOUSING IS 0.013 IN. (0.330 mm). BORE MAY BE CHECKED WITH DIAL INDICATOR MOUNTED ON END OF CRANKSHAFT. THIS CHECK MUST BE MADE WITH FLYWHEEL HOUSING COVER IN PLACE ON ENGINE AND OIL SEAL REMOVED.

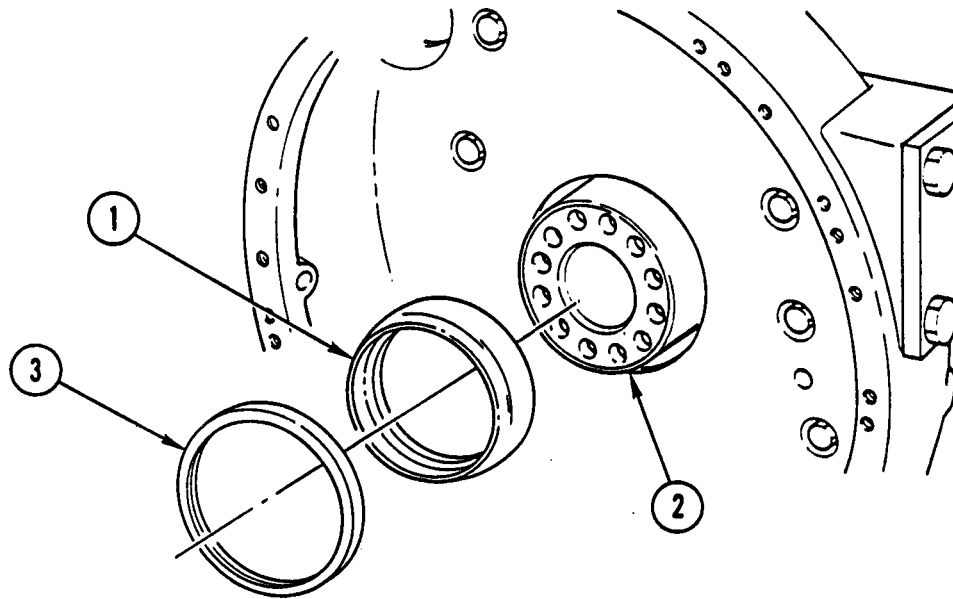
INSTALLATION

1. COAT OUTSIDE OF OIL SEAL EXPANDER (1) WITH LIGHT FILM OF CLEAN ENGINE LUBRICATING OIL AND INSTALL OIL SEAL EXPANDER (1) ON END OF CRANKSHAFT (2).

CAUTION

Keep sealing lip of crankshaft rear oil seal free of dirt and scratches. Do not clean or coat rear oil seal with oil to prevent damage to equipment.

2. INSTALL CRANKSHAFT REAR OIL SEAL (3) CAREFULLY OVER OIL SEAL EXPANDER (1) AND ONTO CRANKSHAFT (2) AS FAR AS OIL SEAL WILL GO BY HAND.
3. REMOVE OIL SEAL EXPANDER (1).

CRANKSHAFT REAR OIL SEAL REPLACEMENT (CONT)

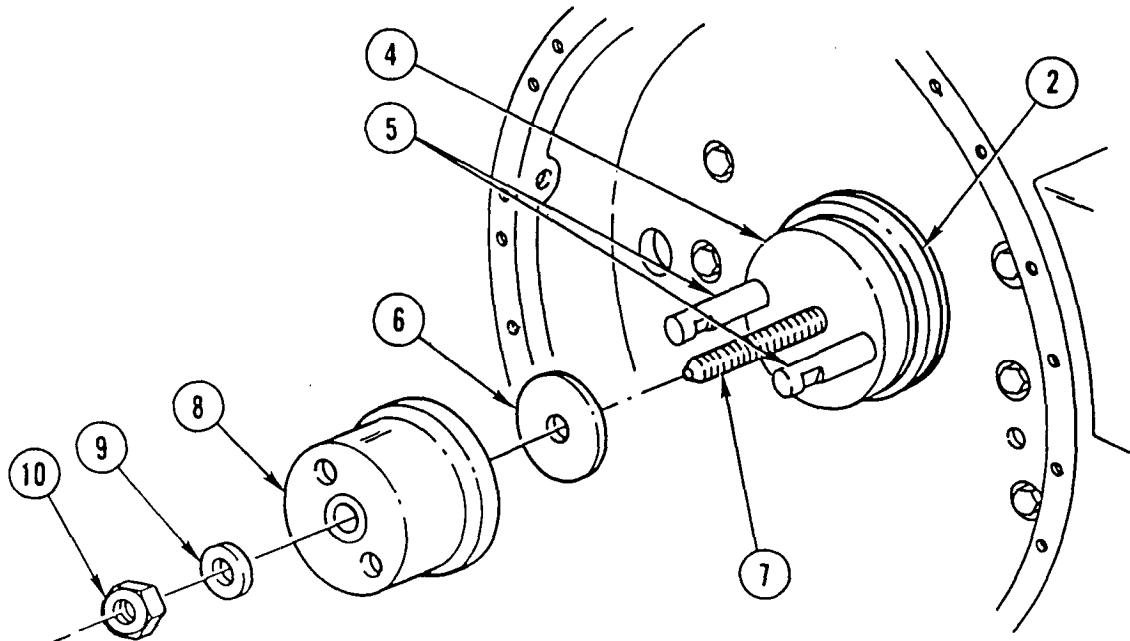

CAUTION

Make sure flywheel housing seal bore, rear of crankshaft, and both sides of oil seal installer base and spacer are clean, smooth, and free of any foreign material or damage to prevent damage to equipment.

4. POSITION OIL SEAL INSTALLER BASE (4) ON REAR OF CRANKSHAFT (2).
5. INSTALL TWO GUIDE STUDS (5) IN TWO FLYWHEEL BOLT HOLES 180 DEGREES APART.
6. HAND-TIGHTEN TWO GUIDE STUDS (5) UNTIL INSTALLER BASE (4) IS TIGHT AGAINST REAR OF CRANKSHAFT (2).
7. INSTALL OIL SEAL INSTALLER SPACER (6) ON CENTER SCREW (7).
8. PLACE OIL SEAL INSTALLER HOUSING (8) OVER CENTER SCREW (7) AND TWO GUIDE STUDS (5) AND POSITION HOUSING (8) AGAINST CRANKSHAFT REAR OIL SEAL.
9. INSTALL THRUST BEARING (9) ON CENTER SCREW (7) WITH LETTERED SIDE OF BEARING (9) AGAINST OIL SEAL INSTALLER HOUSING (8).
10. INSTALL NUT (10) ON CENTER SCREW (7). TIGHTEN NUT UNTIL CRANKSHAFT REAR OIL SEAL IS FIRMLY SEATED.
11. REMOVE OIL SEAL INSTALLER NUT (10), THRUST BEARING (9), INSTALLER HOUSING (8), SPACER (6), GUIDE STUDS (5), AND INSTALLER BASE (4).

NOTE

Follow-on Maintenance:
Install flex plate (page 3-154).

CRANKSHAFT OVERSIZE REAR OIL SEAL REPLACEMENT

This task covers: a. Removal b. Inspection c. Installation

Tools and Special Equipment:

Shop Equipment, SC 4910-95-CL-A31
 Tool Kit, SC 5180-90-CL-N05
 Oil Seal Remover, J35993
 Oil Seal Expander, J35685-A
 Oil Seal Installer, J35686

Equipment Condition:

Reference
 Page 3-148

Condition Description
 Flywheel Housing
 Removed

Materials/Parts:

Seal	P/N 2327984TA
Sleeve	P/N J-2037
Cloth, Abrasive	Appendix B, Item 10

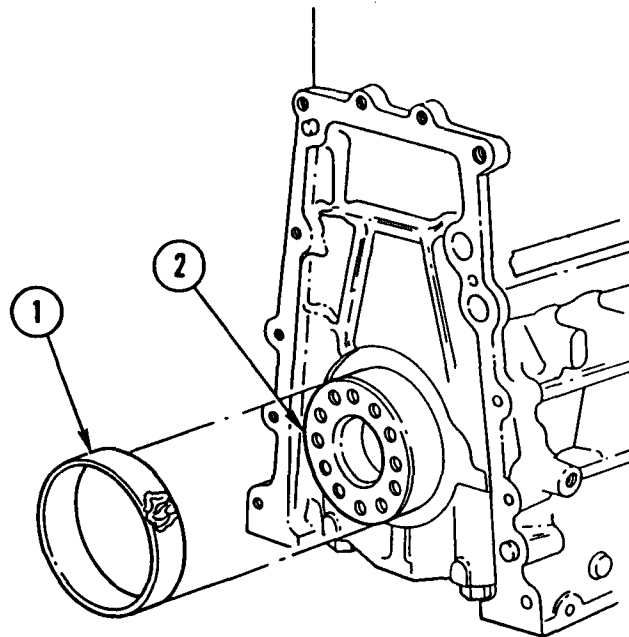
REMOVAL
**CAUTION**

Be careful not to damage crankshaft surface when peening wear sleeve. Do not use puller or cut sleeve to remove wear sleeve.

REMOVE AND DISCARD CRANKSHAFT WEAR SLEEVE (1) FROM REAR OIL SEAL CRANKSHAFT (2) CONTACT AREA. PEEN OUTSIDE CRANKSHAFT WEAR SLEEVE DIAMETER CAREFULLY UNTIL IT STRETCHES ENOUGH TO SLIDE OFF CRANKSHAFT (2).

CRANKSHAFT OVERSIZE REAR OIL SEAL REPLACEMENT (CONT)

INSPECTION

CAUTION

Make sure flywheel housing seal bore, rear of crankshaft, and both sides of oil seal installer base and spacer are clean, smooth, and free of any foreign material or damage to prevent damage to equipment.

NOTE

Minor wear line on crankshaft surface should be evident where contact was made with oil seal. This is normal.

1. INSPECT OIL SEAL CONTACT SURFACE OF CRANKSHAFT CAREFULLY.
2. INSPECT EXPOSED AREA OF CRANKSHAFT FOR DIRT, BURRS, OR ROUGH SURFACES.
3. IF NECESSARY, CLEAN/SMOOTH CRANKSHAFT SURFACE WITH ABRASIVE CLOTH.

INSTALLATION

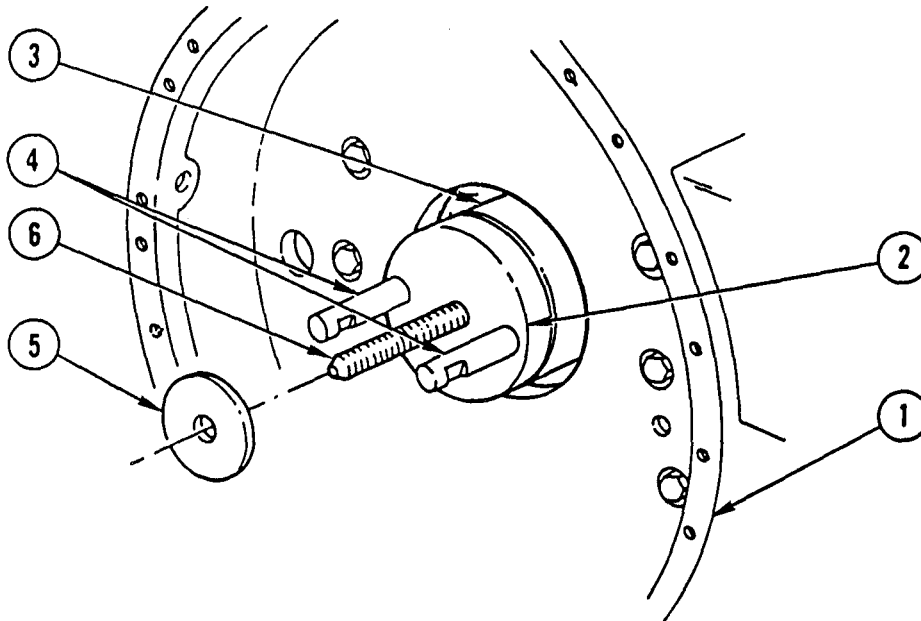

1. INSTALL FLYWHEEL HOUSING (1) (PAGE 3-148).
2. POSITION OIL SEAL INSTALLER BASE (2) ON REAR OF CRANKSHAFT (3).
3. INSTALL TWO GUIDE STUDS (4) IN TWO FLYWHEEL BOLT HOLES 180 DEGREES APART.
4. HAND-TIGHTEN TWO GUIDE STUDS (4) UNTIL INSTALLER BASE (2) IS TIGHT AGAINST REAR OF CRANKSHAFT (3).
5. INSTALL OIL SEAL INSTALLER SPACER (5) ON CENTER SCREW (6).

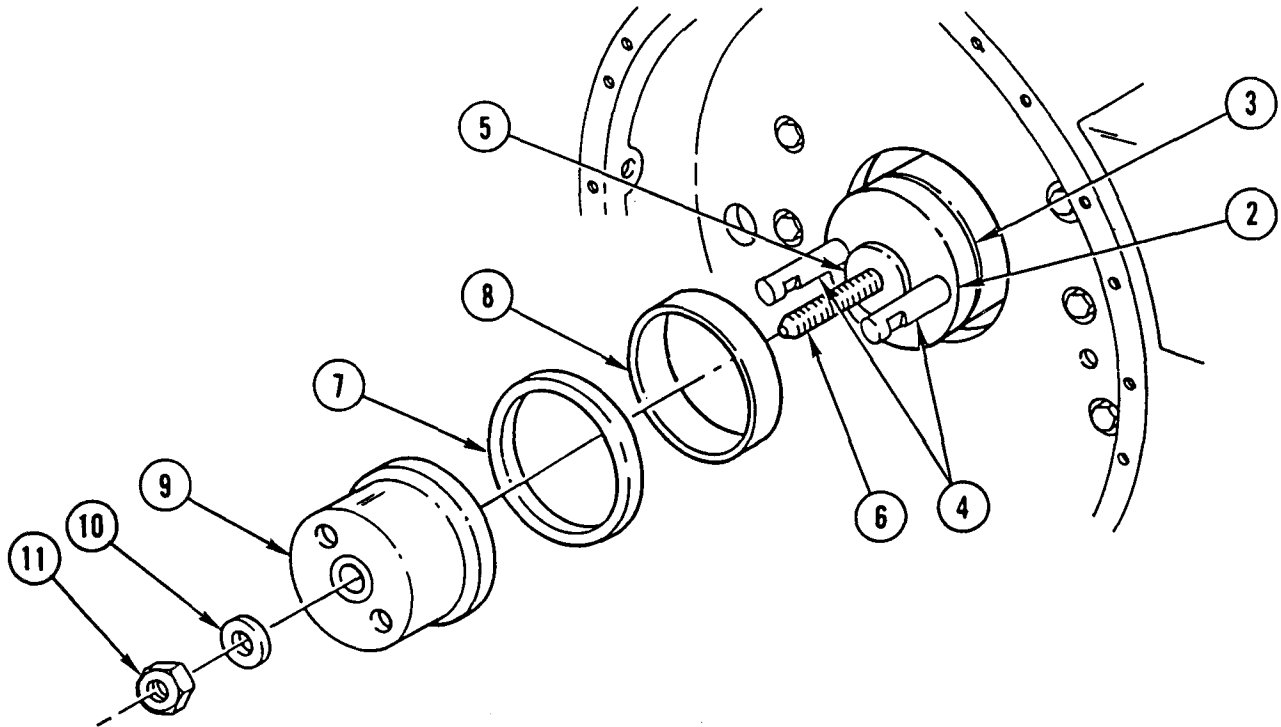

NOTE

Note direction of indication arrow on new seal showing engine rotation.

6. CAREFULLY INSTALL NEW CRANKSHAFT OVERSIZE REAR OIL SEAL (7) ON NEW WEAR SLEEVE (8) FROM CHAMFERED END OF SLEEVE. POSITION OIL SEAL (7) IN MIDDLE OF SLEEVE (8) WITH CASE SIDE OF SEAL AWAY FROM CHAMFERED END OF SLEEVE.
7. POSITION AND INSTALL OIL SEAL AND SLEEVE ASSEMBLY IN OIL SEAL INSTALLER HOUSING (9) WITH SEAL CASING AGAINST INSTALLER HOUSING.
8. PLACE OIL SEAL INSTALLER HOUSING (9) WITH OIL SEAL AND SLEEVE ASSEMBLY OVER CENTER SCREW (6) AND TWO GUIDE STUDS (4) AND POSITION SLEEVE (8) AGAINST REAR OF CRANKSHAFT (3).
9. INSTALL THRUST BEARING (10) ON CENTER SCREW (6) WITH LETTERED SIDE OF BEARING AGAINST OIL SEAL INSTALLER HOUSING (9).
10. INSTALL NUT (11) ON CENTER SCREW (6). TIGHTEN NUT UNTIL CRANKSHAFT OVERSIZE REAR OIL SEAL AND SLEEVE ARE SEATED FIRMLY.
11. REMOVE OIL SEAL INSTALLER NUT (11), THRUST BEARING (10), INSTALLER HOUSING (9), SPACER (5), GUIDE STUDS (4), AND INSTALLER BASE (2).

FLYWHEEL HOUSING REPLACEMENT

This task covers: a. Removal b. Cleaning c. Inspection d. Installation

Tools and Special Equipment:

Shop Equipment, SC 4910-95-CL-A31
Tool Kit, SC 5180-90-CL-N05
Guide Stud (2), J35785
Caulking Gun, 805774
Seal Expander, J35685-A

Materials/Parts:

Eliminator, Gasket Appendix B, Item 18

References:

TM 9-2320-363-20

Equipment Condition:

Reference

Page 3-48 or 3-52

TM 9-2320-363-20

Page 12-3

Page 3-154

Page 3-220

Condition Description

Rear Engine Mounts
Removed

Starter Removed

Engine Installed on
Repair Stand

Flex Plate Removed

Oil Pan Removed

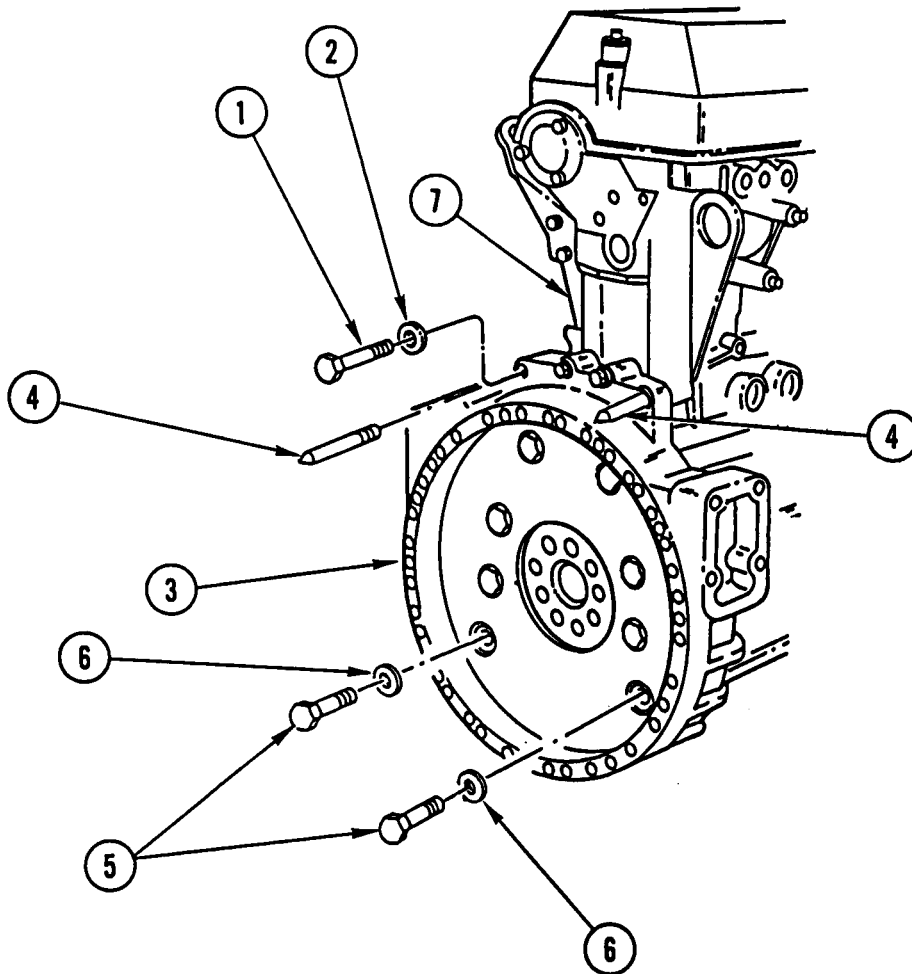
REMOVAL

1. REMOVE FOUR BOLTS (1) AND FOUR WASHERS (2) FROM FLYWHEEL HOUSING (3).
2. INSTALL TWO GUIDE STUDS (4).
3. REMOVE EIGHT BOLTS (5) AND EIGHT WASHERS (6) FROM FLYWHEEL HOUSING (3).

CAUTION

Use soft mallet to tap flywheel housing loose from cylinder block. Failure to use soft mallet could result in damage to equipment.

4. REMOVE FLYWHEEL HOUSING (3).
5. REMOVE AND DISCARD CRANKSHAFT REAR OIL SEAL (PAGE 3-141 or 3-145).
6. REMOVE TWO GUIDE STUDS (4) FROM CYLINDER BLOCK (7).

Use general cleaning methods to clean all parts (page 2-30).

FLYWHEEL HOUSING REPLACEMENT (CONT)

INSPECTION

Inspect all parts for wear or damage.

INSTALLATION

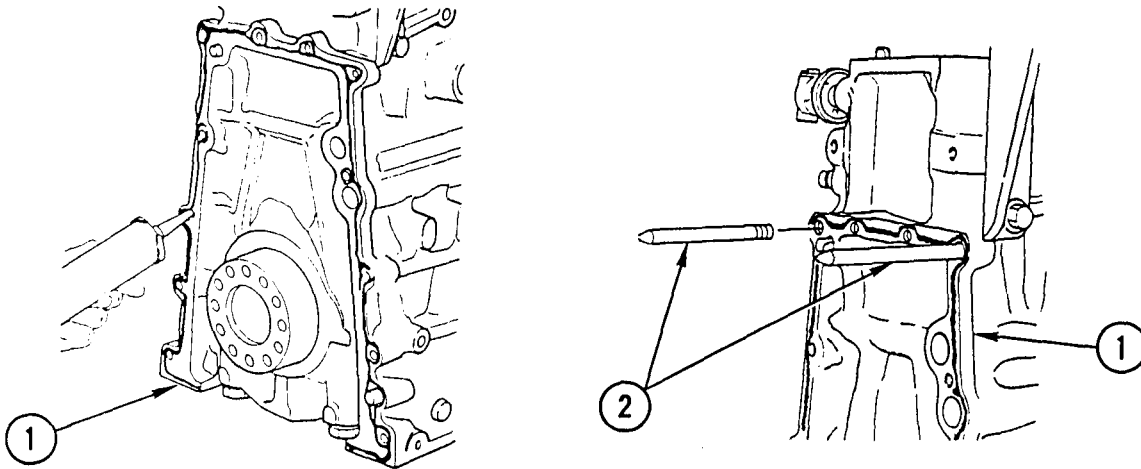

1. APPLY CONTINUOUS 1/16-IN. BEAD OF GASKET ELIMINATOR TO REAR FACE OF CYLINDER BLOCK (1) WHERE IT CONTACTS FLYWHEEL HOUSING.
2. INSTALL TWO GUIDE STUDS (2) ON CYLINDER BLOCK (1).

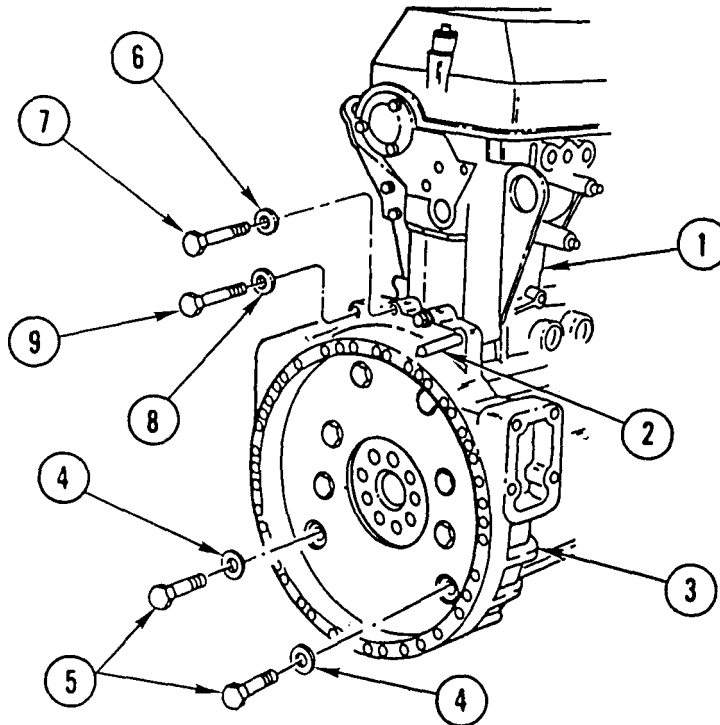

3. POSITION FLYWHEEL HOUSING (3) CAREFULLY ON GUIDE STUDS (2), WORKING IT FORWARD UNTIL FLYWHEEL HOUSING (3) CONTACTS CYLINDER BLOCK (1).
4. INSTALL EIGHT WASHERS (4), EIGHT BOLTS (5), TWO WASHERS (6), AND TWO BOLTS (7) HAND-TIGHT.
5. REMOVE TWO GUIDE STUDS (2) AND INSTALL TWO WASHERS (8) AND TWO BOLTS (9) HAND-TIGHT.

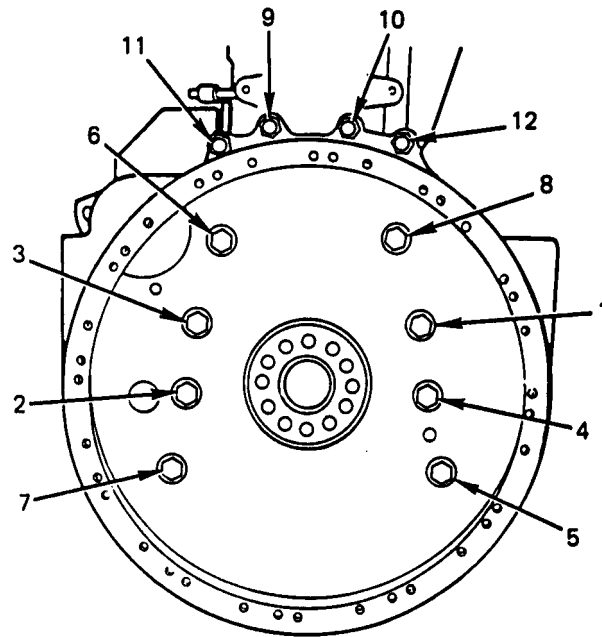

6. TIGHTEN 12 FLYWHEEL HOUSING ATTACHING BOLTS TO 75-93 LB-FT (101-126 N.m) IN SEQUENCE SHOWN.

FLYWHEEL HOUSING REPLACEMENT (CONT)

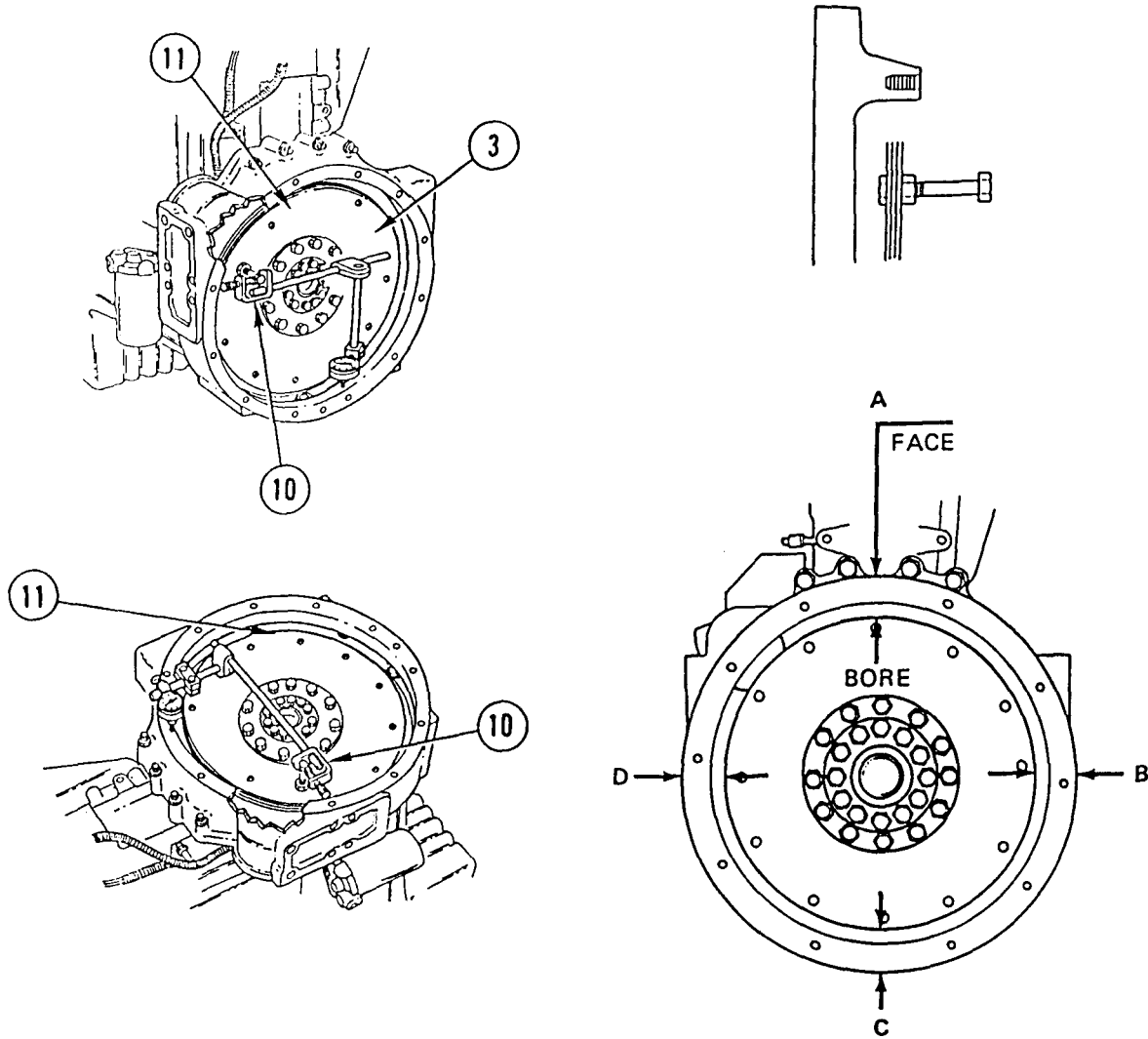

7. INSTALL CRANKSHAFT REAR OIL SEAL (PAGE 3-141 or 3-145).
8. INSTALL FLEX PLATE (PAGE 3-154).

CAUTION
Make sure contact between flywheel housing and end of bolt does not occur to prevent damage to equipment.

9. ASSEMBLE DIAL INDICATOR (10) TO FLEX PLATE (11).

NOTE

Make sure dial indicator is positioned straight and square with flywheel housing bell face or inside bore of bell. Make sure indicator has adequate travel in each direction.

10. USING DIAL INDICATOR (10), CHECK FLYWHEEL HOUSING CONCENTRICITY AND BOLTING FLANGE FACE RUNOUT.
11. MAKE SURE ENGINE IS IN VERTICAL POSITION WITH FLYWHEEL HOUSING (3) END UP.
12. MAKE SURE END PLAY IS IN ONE DIRECTION ONLY. TAP END OF CRANKSHAFT WITH SOFT HAMMER TO POSITION IT TOWARD ONE END OF BLOCK.

NOTE

Maximum total indicator reading must not exceed 0.013 in. (0.33 mm) for bore or face.

13. ADJUST DIAL INDICATOR (10) TO READ ZERO. ROTATE CRANKSHAFT ONE FULL REVOLUTION, TAKING READINGS AT 90-DEGREE INTERVALS (FOUR READINGS EACH FOR BORE BOLTING AND FACE).
14. IF RUNOUT EXCEEDS MAXIMUM LIMITS, REMOVE FLYWHEEL HOUSING (3) AND CHECK FOR DIRT OR FOREIGN MATERIAL BETWEEN FLYWHEEL HOUSING AND CYLINDER BLOCK OR OIL PAN MATING SURFACE. CLEAN MATING SURFACES. INSTALL FLYWHEEL HOUSING (3) AND REPEAT STEPS 9 THRU 13.
15. IF READINGS ARE NOT WITHIN SPECIFICATION, REPLACE FLYWHEEL HOUSING (3).
16. REPEAT STEPS 9 THRU 13 TO CHECK FLYWHEEL HOUSING (3) CONCENTRICITY AND BOLTING FLANGE FACE RUNOUT.

NOTE**Follow-on Maintenance:**

Install oil pan (page 3-220).
Remove engine from stand (page 12-3).
Install starter (TM 9-2320-363-20).
Install rear engine mounts (page 3-48 or 3-52).

FLEX PLATE REPLACEMENT AND REPAIR

This task covers: a. Removal b. Disassembly c. Cleaning d. Inspection e. Repair f. Assembly
g. Installation

INITIAL SETUP

Tools and Special Equipment:

Shop Equipment, SC 4910-95-CL-A31
Tool Kit, SC 5180-90-CL-N05
Guide Stud Set, J36235

Equipment Condition:

Reference

Page 3-234

Condition Description

Transmission Removed

Materials/Parts:

Plate, Scuff P/N 5100532
International Appendix B, Item 29
Compound No. 2

REMOVAL

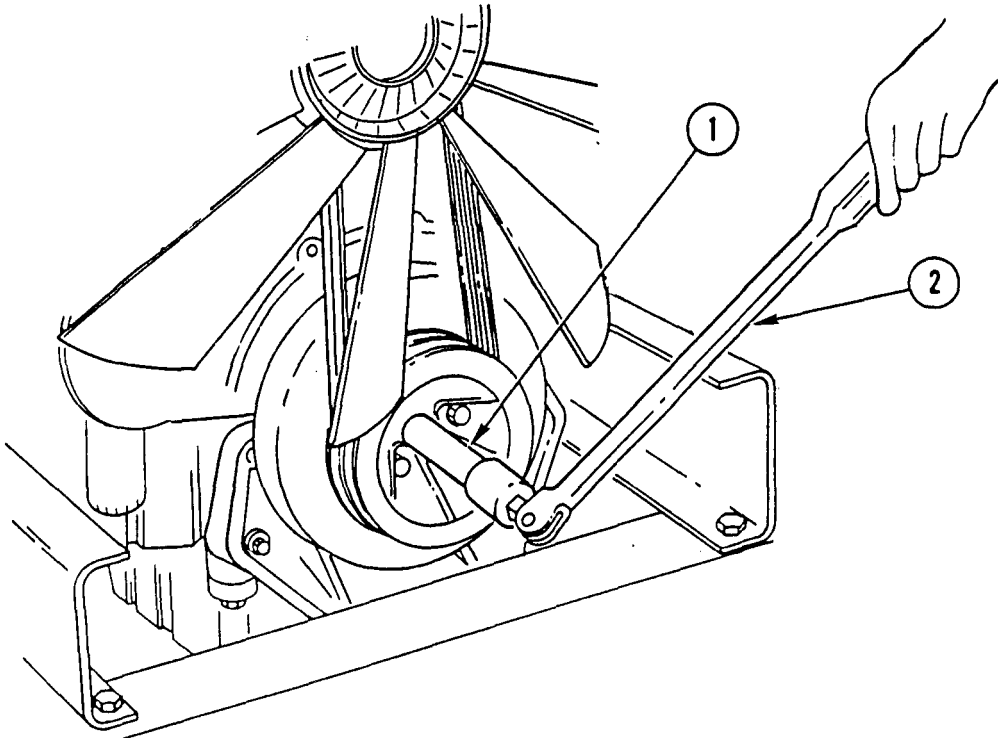

NOTE

Use 3/4-in. extension and hinged handle bar to prevent crankshaft rotation when removing two bolts.

1. INSERT 3/4-IN. EXTENSION (1), 4-6 IN. LONG, INTO SQUARE OPENING IN CENTER OF CRANKSHAFT PULLEY AND HOLD EXTENSION (1) WITH HINGED HANDLE BAR (2).

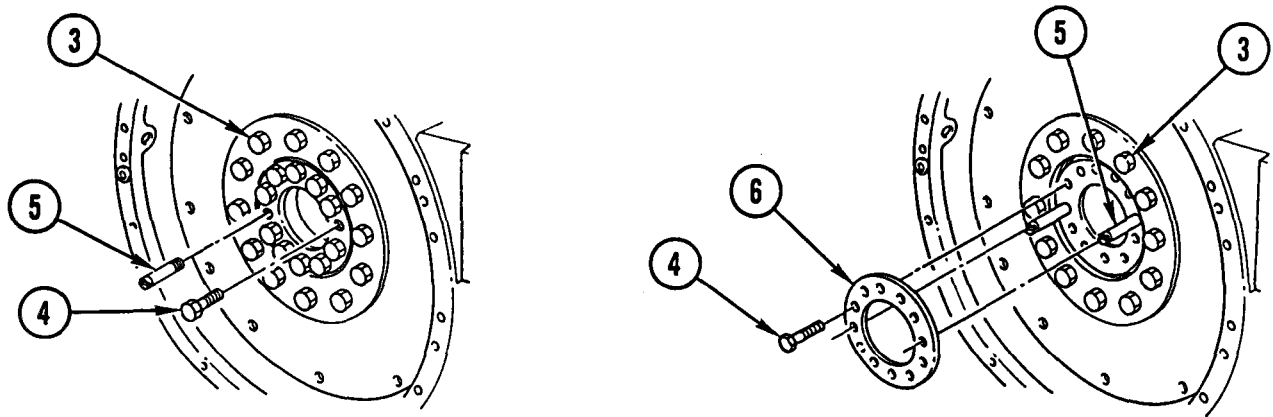
**NOTE**

- If flex plate assembly is to be repaired, go to step 2.
- If flex plate assembly is not to be repaired, go to step 3.

2. LOOSEN 12 BOLTS (3).
3. REMOVE TWO BOLTS (4) AT 3 AND 9 O'CLOCK POSITIONS AND INSTALL TWO GUIDE STUDS (5).
4. REMOVE REMAINING 10 BOLTS (4).
5. REMOVE AND DISCARD SCUFF PLATE (6).

FLEX PLATE REPLACEMENT AND REPAIR (CONT)

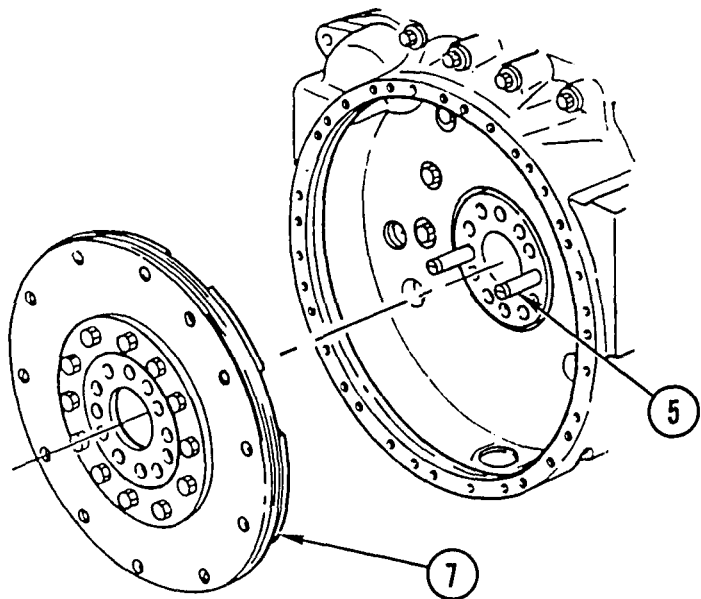

REMOVE FLEX PLATE ASSEMBLY (7) FROM TWO GUIDE STUDS (5).

DISASSEMBLY

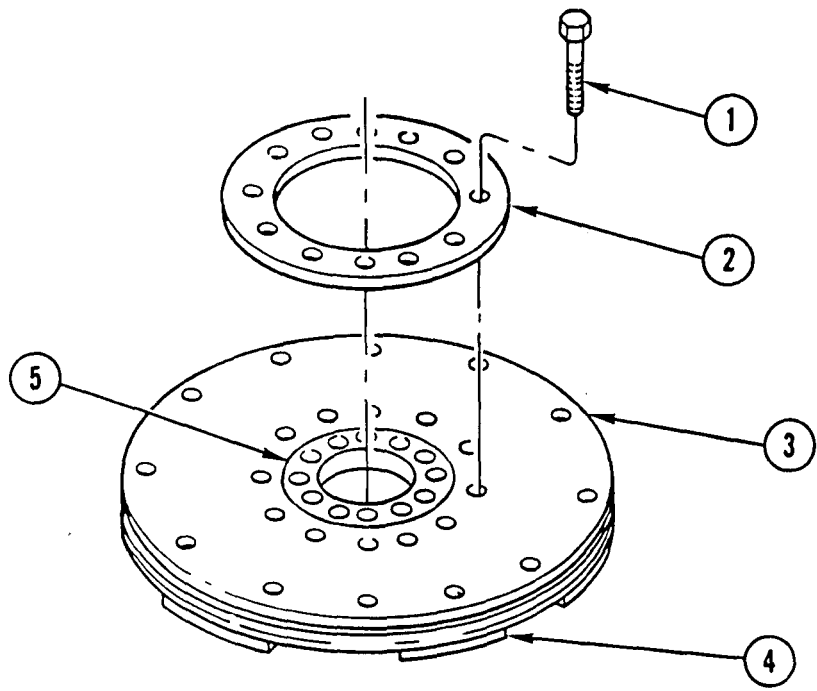

REMOVE 12 BOLTS (1), FLEX PLATE (2), 4 DISKS (3), AND DISK ASSEMBLY (4) FROM COUPLING (5).

CLEANING

1. MAKE SURE ALL SURFACES OF COUPLING, DISK ASSEMBLY, FOUR DISKS, AND FLEX PLATE ARE CLEAN AND FREE FROM ANY FOREIGN MATERIAL.
2. USE GENERAL CLEANING METHODS TO CLEAN ALL PARTS (PAGE 2-30).

INSPECTION

1. INSPECT PARTS FOR RUST, CRACKS, OR DAMAGE. IF ANY OF THESE CONDITIONS ARE PRESENT, REPLACE PARTS.
2. INSPECT ALL PARTS FOR WEAR OR DAMAGE.

REPAIR

Use general repair methods to repair damaged parts (page 2-33).

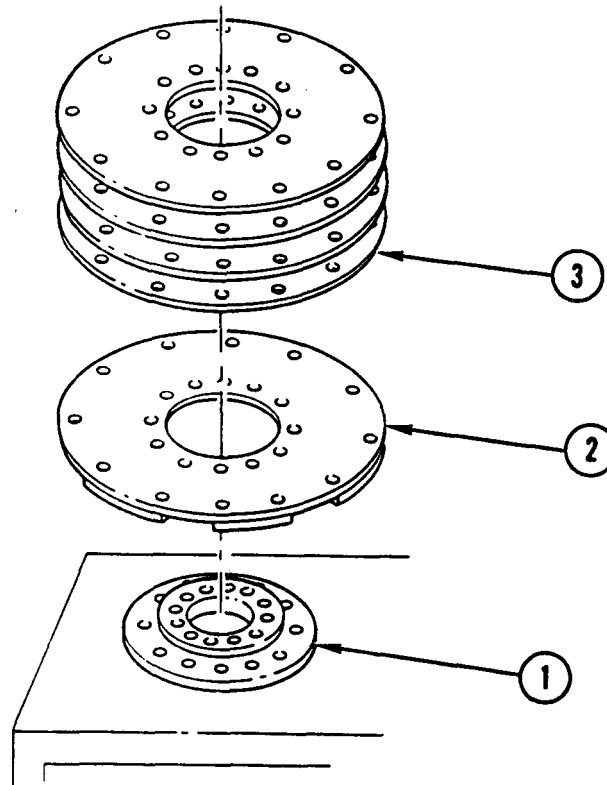
ASSEMBLY

1. PLACE COUPLING (1), RECESSED SIDE DOWN, ON BENCH.
2. INSTALL DISK ASSEMBLY (2) ON COUPLING (1) WITH REINFORCEMENT SIDE DOWN.
3. INSTALL FOUR DISKS (3) ON TOP OF DISK ASSEMBLY (2).

FLEX PLATE REPLACEMENT AND REPAIR (CONT)

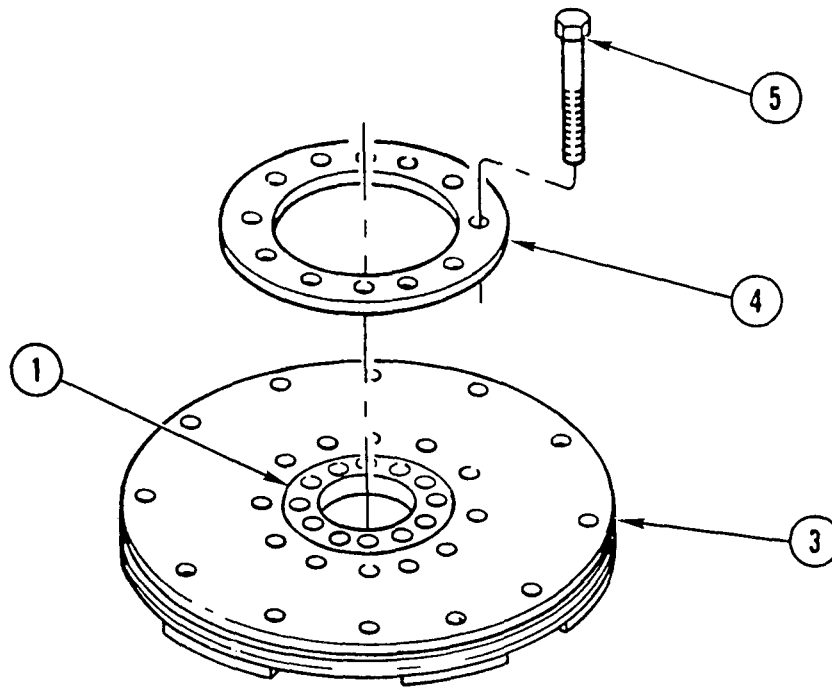

4. INSTALL FLEX PLATE (4) ON TOP OF FOUR DISKS (3).
5. ALINE BOLT HOLES AND INSTALL 12 BOLTS (5) HAND-TIGHT IN COUPLING (1).

INSTALLATION

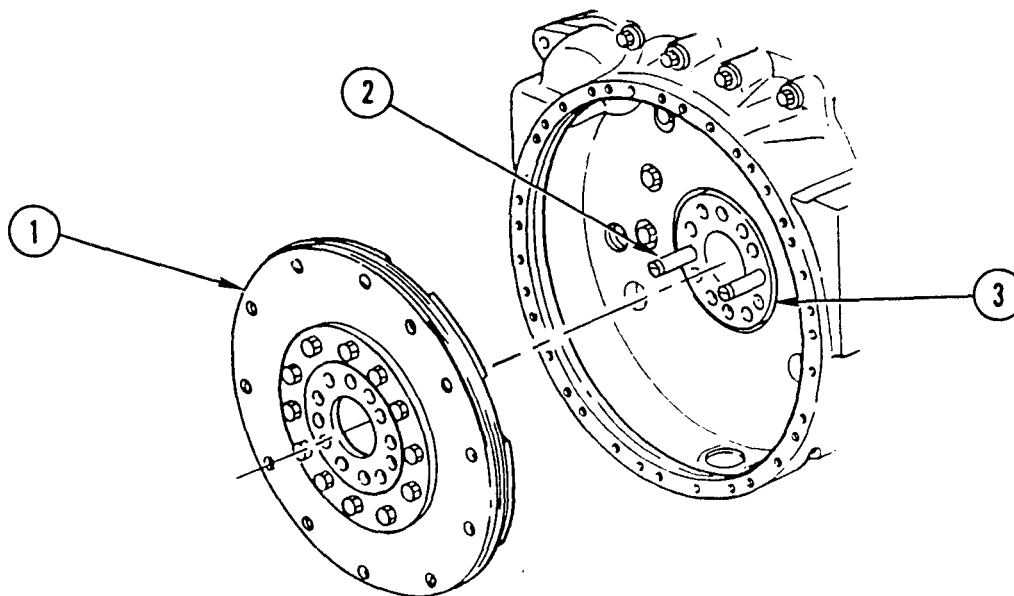

NOTE

Make sure mating surfaces of crankshaft butt and flex plate assembly are clean and dry.

1. INSTALL FLEX PLATE ASSEMBLY (1) ON TWO GUIDE STUDS (2) AND SLIDE FORWARD AGAINST CRANKSHAFT (3) BUTT.

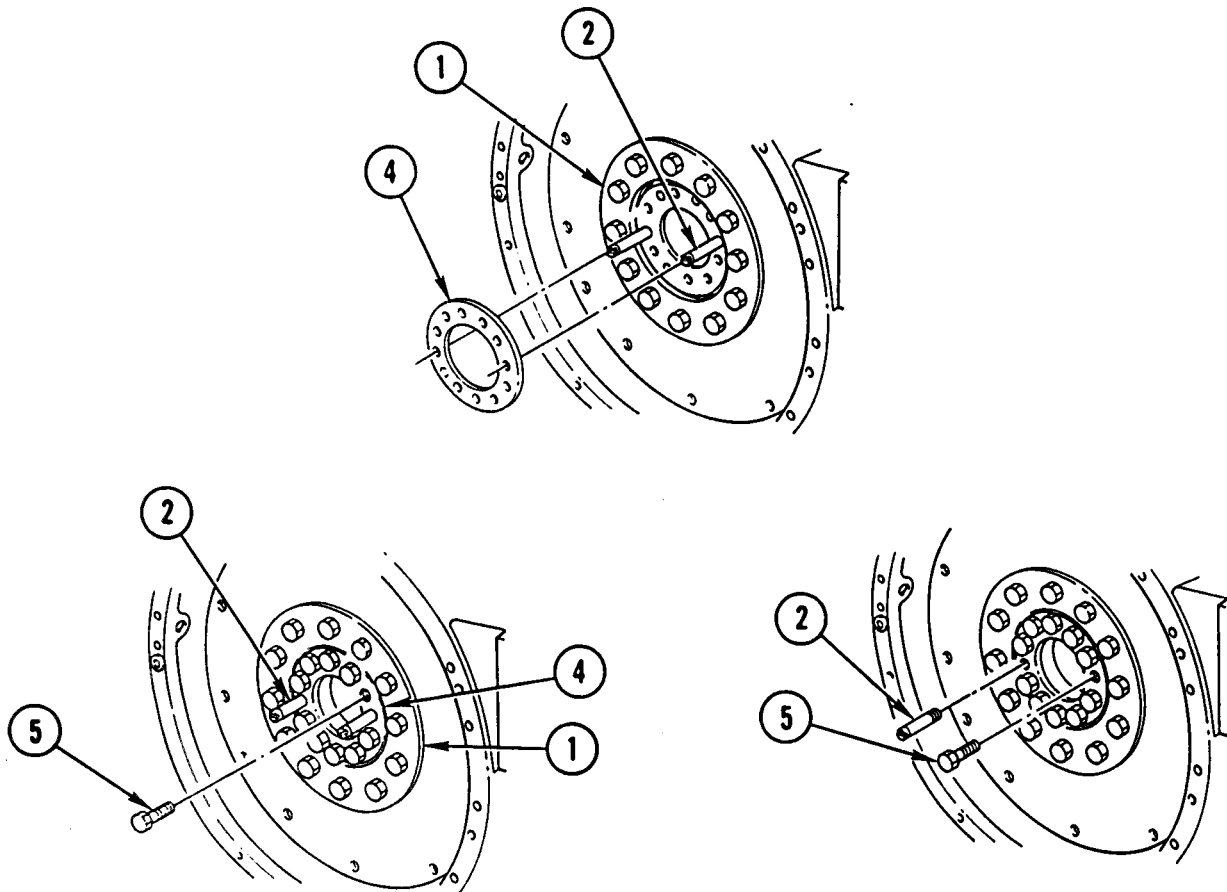

2. INSTALL NEW SCUFF PLATE (4) ON TWO GUIDE STUDS (2) AND SLIDE FORWARD AGAINST FLEX PLATE ASSEMBLY (1).

NOTE

Do not apply international Compound No. 2 on underside of bolt heads.

3. APPLY INTERNATIONAL COMPOUND NO. 2 ON THREADS OF BOLTS (5).
4. INSTALL 10 BOLTS (5) THRU SCUFF PLATE (4) AND FLEX PLATE ASSEMBLY (1) AND TIGHTEN TO 50 LB-FT (63 N.m).
5. REMOVE TWO GUIDE STUDS (2) AND INSTALL REMAINING TWO BOLTS (5). TIGHTEN BOLTS TO 50 LB-FT (63 N.m).

FLEX PLATE REPLACEMENT AND REPAIR (CONT)

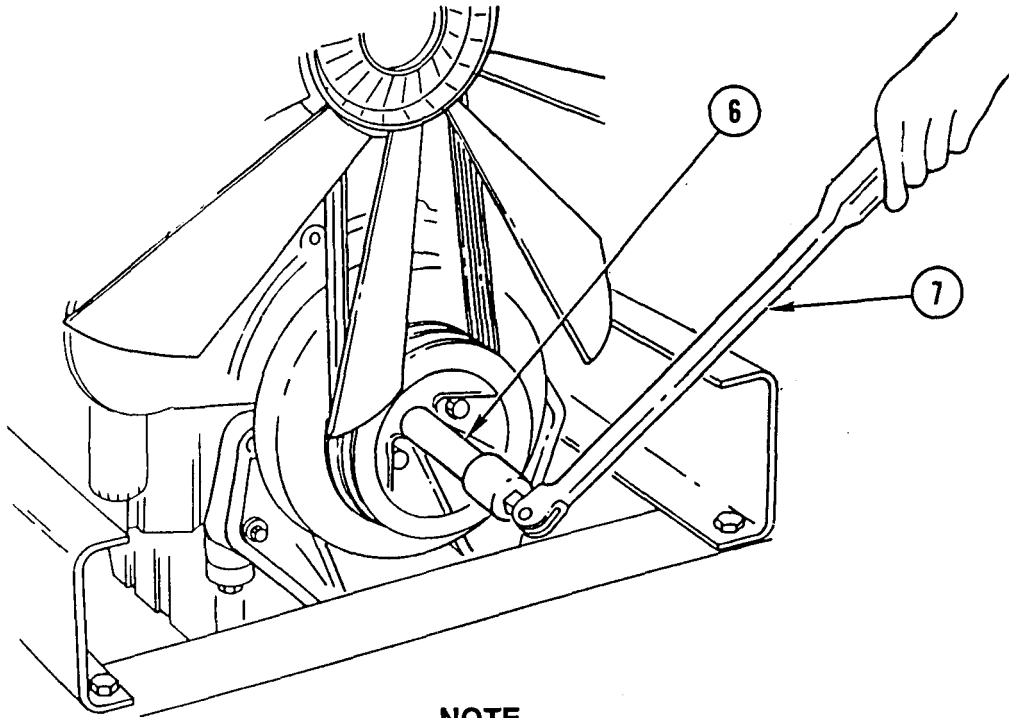

NOTE

Use 3/4-in. extension and hinged handle bar to prevent crankshaft rotation when tightening bolts.

6. INSERT 3/4-IN. EXTENSION (6), 4-6 IN. LONG, INTO SQUARE OPENING IN CENTER OF CRANKSHAFT PULLEY AND HOLD EXTENSION (6) WITH HINGED HANDLE BAR (7).

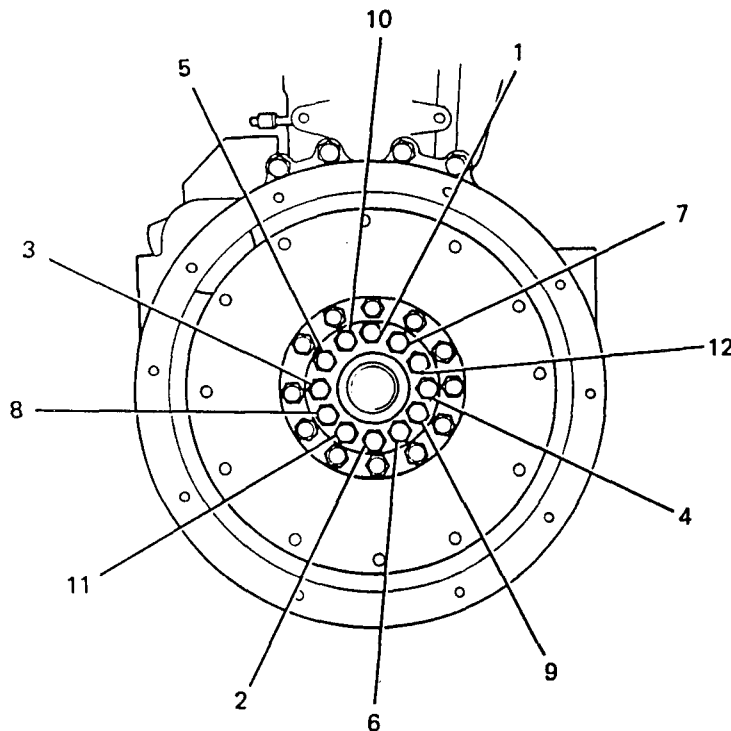

7. TIGHTEN 12 INNER BOLTS IN CRISSCROSS PATTERN TO 180-190 LB-FT (244-257 N.m).

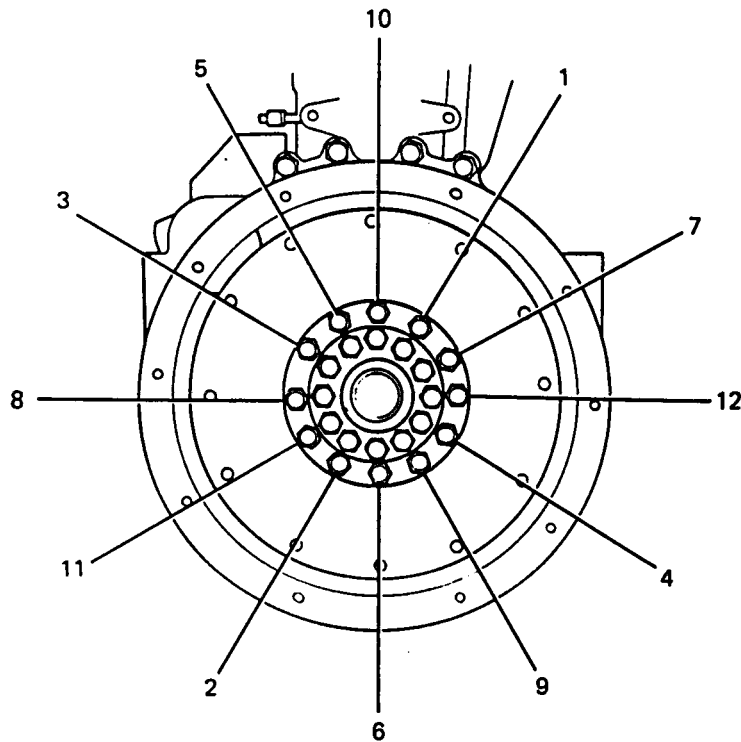

8. TIGHTEN 12 OUTER BOLTS IN CRISSCROSS PATTERN TO 95-115 LB-FT (130-156 N.m).

NOTE

Follow-on Maintenance:

Install transmission (page 3-234).

CAMSHAFT AND BEARINGS REPLACEMENT

This task covers: a. Removal b. Cleaning c. Inspection d. Installation

INITIAL SETUP

Tools and Special Equipment:

Shop Equipment, SC 4910-95-CL-A31
Tool Kit, SC 5180-90-CL-N05
Rocker Stud Socket, J36003
Cam Gear Retaining Tool, J35652
Cam Gear Pilot, J35906
Caulking Gun, 805774

Materials/Parts:

Ring, Seal (2)	P/N 8929740
Seal, Racetrack	P/N 23522975
Oil Lubricating	Appendix B, Item 37
Eliminator, Gasket	Appendix B, Item 18
Plastigauge	Appendix B, Item 46
Towel, Shop	Appendix B, Item 62
International Compound No. 2	Appendix B, Item 29
Tag, Identification	Appendix B, Item 55
Solvent, Drycleaning	Appendix B, Item 54

Personnel Required: (2)

References:

TM 9-2320-363-20

Equipment Condition:

Reference	Condition Description
TM 9-2320-363-20	Tachometer Drive Removed
Page 3-183	Rocker Arm Assemblies Removed

General Safety Instructions:

WARNING

- To prevent injury, compressed air will not exceed 30 psi (207 kPa). Use only with effective chip guarding and personal protective equipment, goggles, shield, and gloves.
- Camshaft weighs 53 lb (24 kg). Attach suitable lifting device prior to removal to prevent possible injury to personnel.
- Adhesives, solvents, and sealing compounds can burn easily, can give off harmful vapors, and are harmful to skin and clothing. To avoid injury or death, keep away from open fire and use in well-ventilated area. If adhesive, solvent or sealing compound gets on skin or clothing, wash immediately with soap and water.

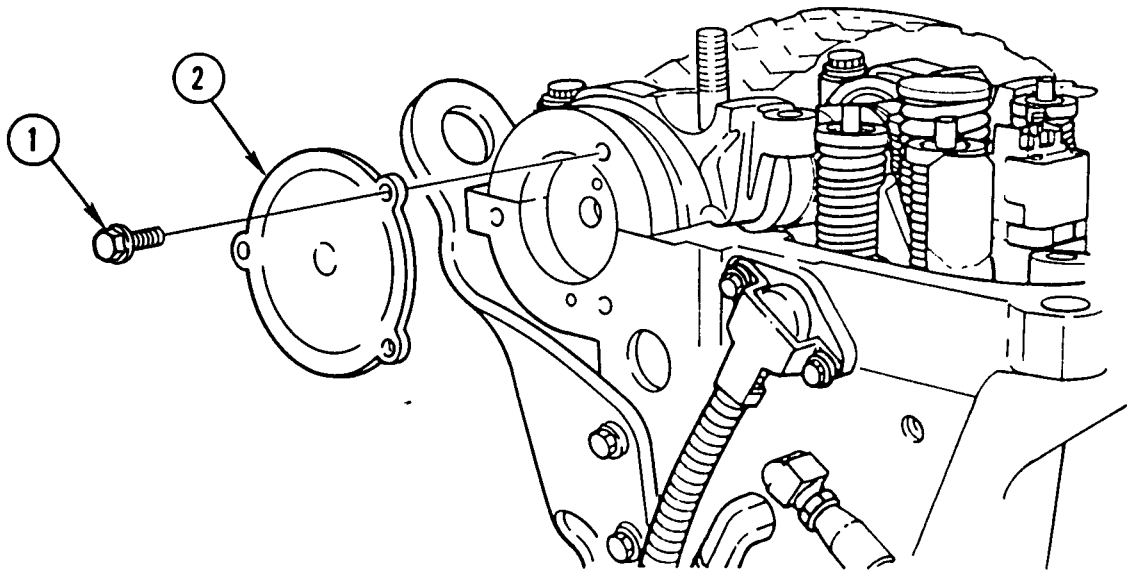
REMOVAL

1. REMOVE THREE BOLTS (1) AND REAR CAMSHAFT COVER (2).
2. WITH DIAL INDICATOR (3), PLACE POINTER IN CONTACT WITH SIDE OF CAMSHAFT LOBE (4).

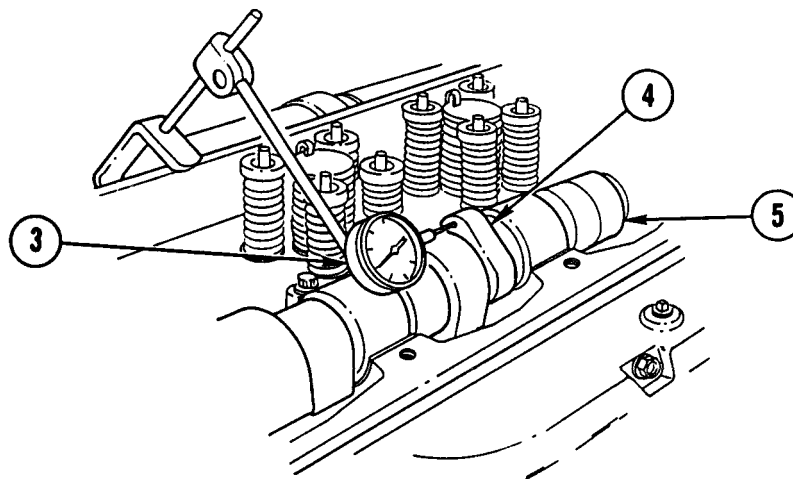

3. GRASP CAMSHAFT (5) BETWEEN CAMSHAFT CAPS AND MOVE CAMSHAFT AS FAR FORWARD AS POSSIBLE. HOLD IN THAT POSITION AND ZERO DIAL INDICATOR (3).
4. MOVE CAMSHAFT (5) TO REAR AS FAR AS POSSIBLE. READ AND RECORD TOTAL AMOUNT OF END PLAY. ALLOWABLE CAMSHAFT END PLAY IS 0.003-0.015 IN. (0.076-0.381 mm).
5. IF END PLAY IS BEYOND MAXIMUM LIMIT, REMOVE AND REPAIR OR REPLACE CAMSHAFT DRIVE GEAR ASSEMBLY.

CAMSHAFT AND BEARINGS REPLACEMENT (CONT)

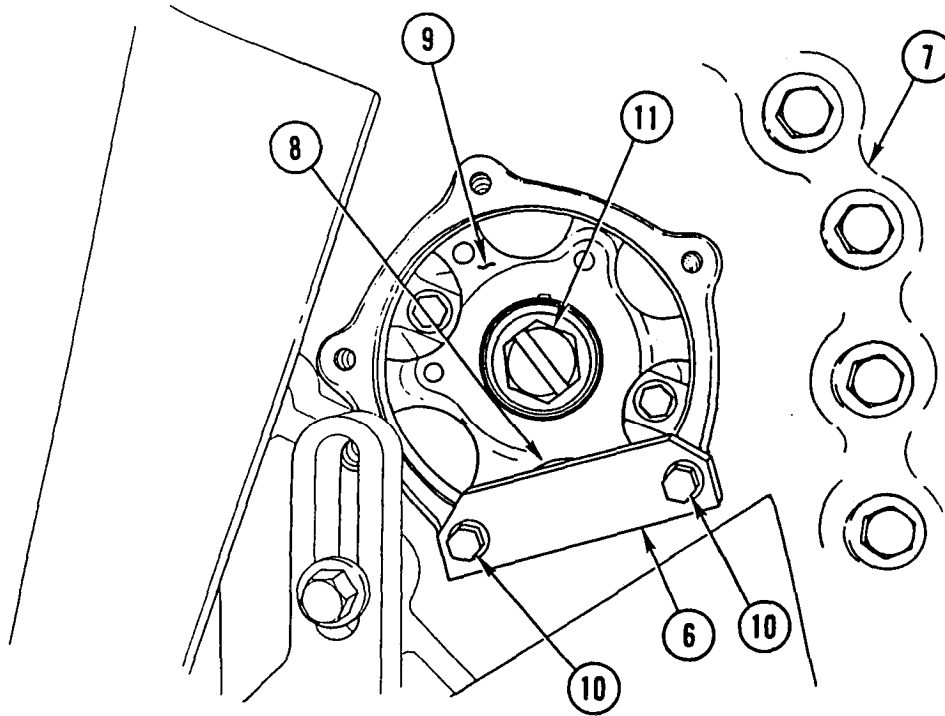

CAUTION

Use only following method to hold camshaft drive gear stationary while loosening or tightening camshaft drive gear bolt to prevent damage to equipment.

NOTE

- After inserting shoe of camshaft drive gear retaining tool thru access hole of camshaft drive gear, it may be necessary to bar engine over slightly to align bolt holes in retaining tool with bolt holes in drive gear access cover.
 - If necessary, bar engine using accessory drive pulley retaining nut to align access hole.
6. INSTALL CAMSHAFT DRIVE GEAR RETAINING TOOL (6) ON GEAR HOUSING (7) ENGAGING ONE ACCESS HOLE (8) IN CAMSHAFT DRIVE GEAR (9). INSTALL TWO BOLTS (10) IN RETAINING TOOL (6) AND GEAR HOUSING (7).
 7. REMOVE CAMSHAFT DRIVE GEAR BOLT (11).
 8. REMOVE TWO BOLTS (10) AND CAMSHAFT DRIVE GEAR RETAINING TOOL (6) FROM GEAR HOUSING (7).

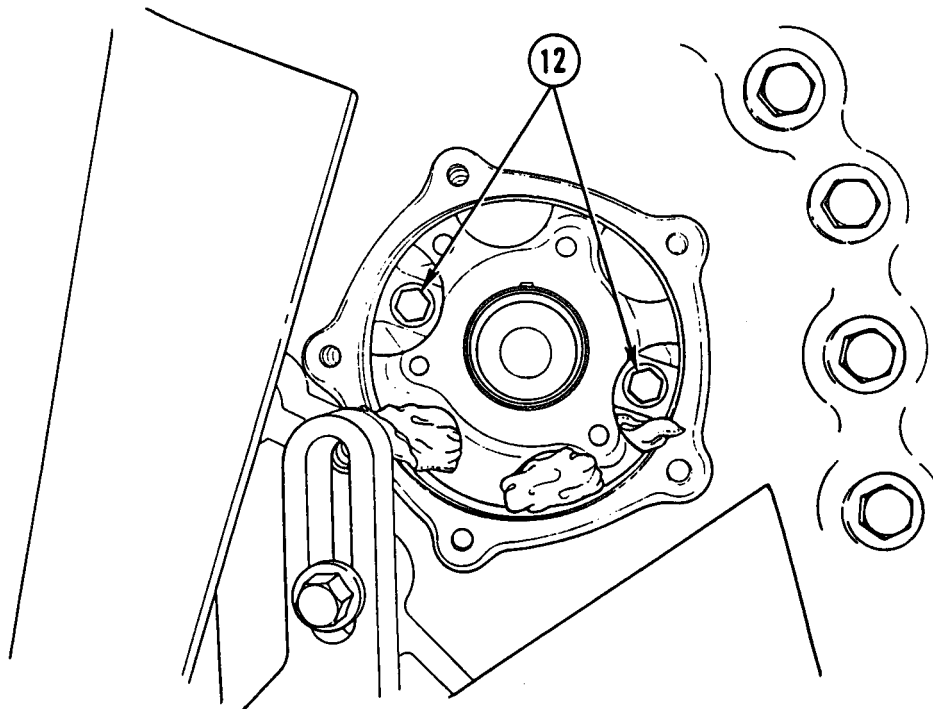
**CAUTION**

Clean shop towel may be inserted into gear housing assembly opening to trap bolts in case they are dropped. Do not allow shop towel to drop into gear housing assembly to prevent damage to equipment.

NOTE

It may be necessary to bar engine over to align access holes in camshaft drive gear with mounting bolts in camshaft thrust plate.

9. REMOVE TWO BOLTS (12).

CAMSHAFT AND BEARINGS REPLACEMENT (CONT)

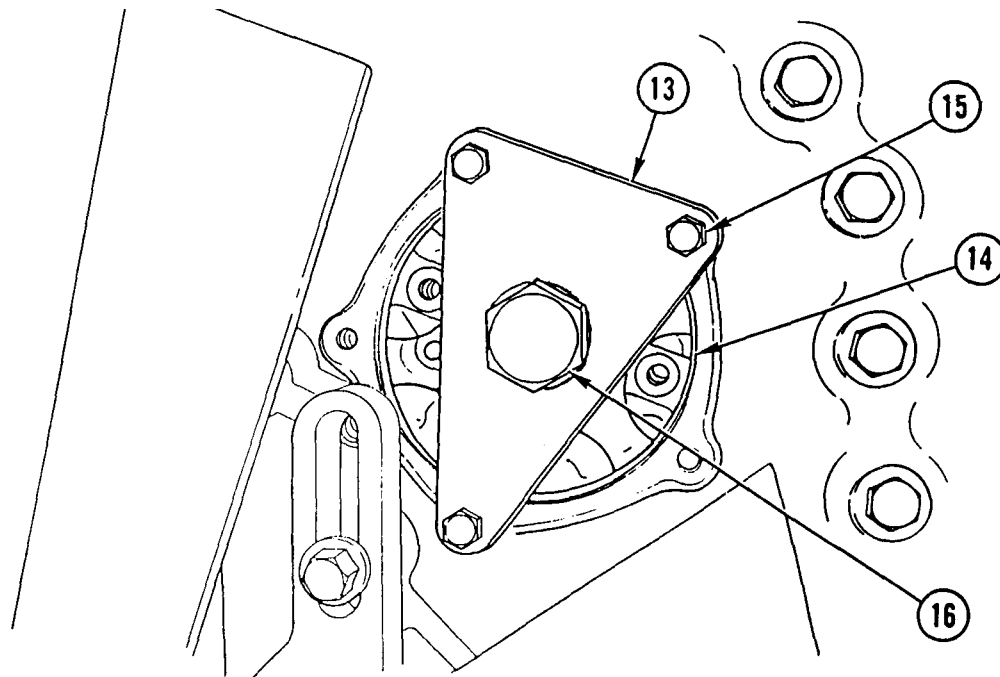

NOTE

Performing step 10 will move camshaft drive gear hub and thrust plate forward approximately 1/4 in. (6-7 mm) until thrust plate seal is clear of camshaft front bearing cap and cylinder head.

10. INSTALL CAMSHAFT GEAR PILOT (13) ON CAMSHAFT DRIVE GEAR ACCESS OPENING (14) AND INSTALL THREE BOLTS (15). THREAD PILOT PULLER SCREW (16) INTO END OF CAMSHAFT DRIVE GEAR HUB UNTIL PULLER SCREW (16) BOTTOMS OUT.

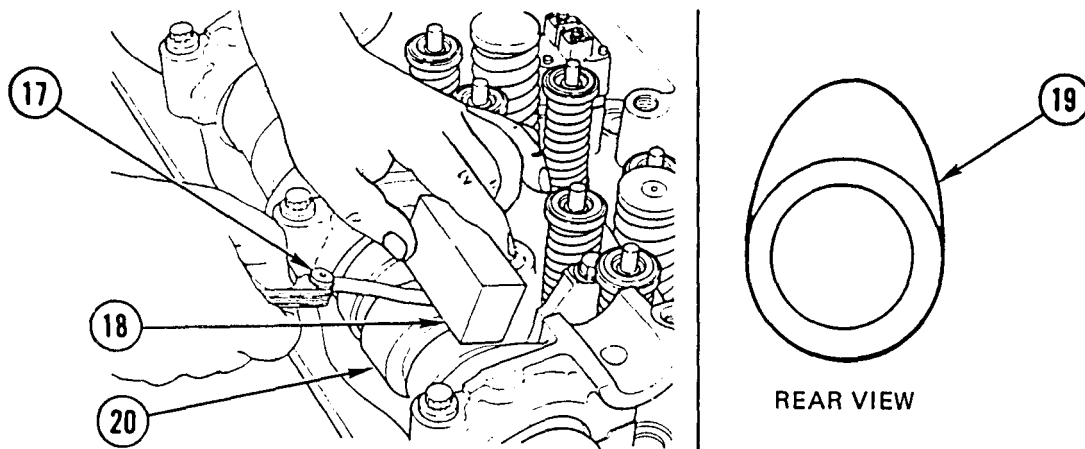

11. IF THERE IS DOUBT OF CAMSHAFT ACCEPTABILITY, DETERMINE EXTENT OF CAMSHAFT LOBE WEAR AS FOLLOWS:
 - A. USING SET OF 0.0015-0.010 IN. (0.038-0.254 MM) FEELER GAGES (17) AND PIECE OF SQUARE, HARD MATERIAL (18). MEASURE FLATS ON INJECTOR RISE SIDE (19) OF CAMSHAFT LOBES (20).

- B. IF FLATS MEASURE LESS THAN 0.003 IN (0.076 MM) IN DEPTH, BUT THERE ARE NO OTHER CAMSHAFT DEFECTS, CAMSHAFT IS SATISFACTORY.

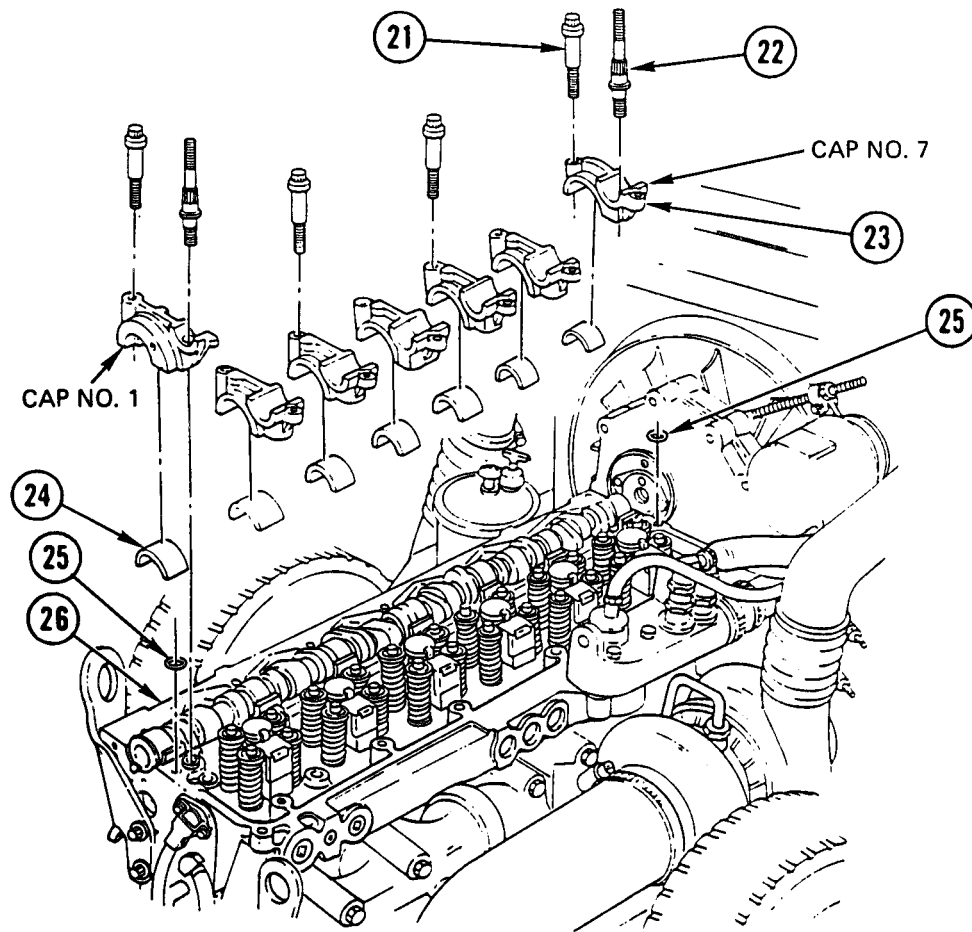

12. REMOVE FOUR CAMSHAFT CAP BOLTS (21).
13. USING ROCKER STUD SOCKET, REMOVE TWO ROCKER SHAFT STUDS (22) FROM CAMSHAFT BEARING CAPS (23) NO. 1 AND NO. 7.

CAUTION

Camshaft bearing caps are numbered and must be kept in sequence and reinstalled in original positions to prevent damage to equipment. Camshaft bearing caps cannot be interchanged or transferred to another cylinder head.

NOTE

If camshaft bearing shells are to be reused tag all parts. Shell must be kept with same camshaft bearing cap.

14. REMOVE SEVEN CAMSHAFT BEARING CAPS (23) AND SEVEN UPPER CAMSHAFT BEARING SHELLS (24) TOGETHER AS UNITS.
15. REMOVE AND DISCARD TWO SEAL RINGS (25) BETWEEN CAMSHAFT BEARING CAPS (23) NO. 1 AND NO. 7 AND CYLINDER HEAD (26).

CAMSHAFT AND BEARINGS REPLACEMENT (CONT)

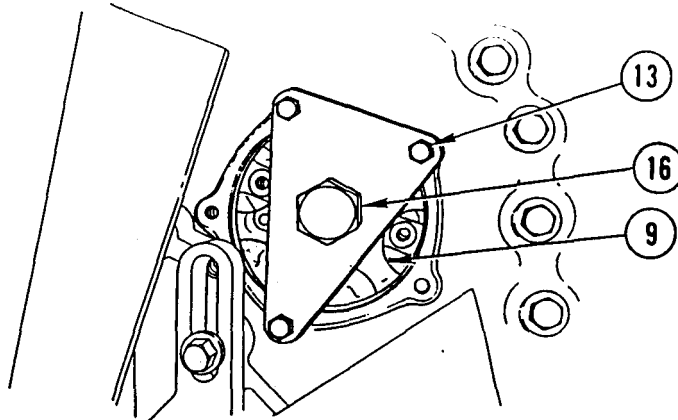

16. REMOVE PILOT PULLER SCREW (16). CAMSHAFT GEAR PILOT (13) WILL REMAIN IN PLACE, HOLDING CAMSHAFT DRIVE GEAR (9) IN CONTACT WITH ADJUSTABLE IDLER GEAR.

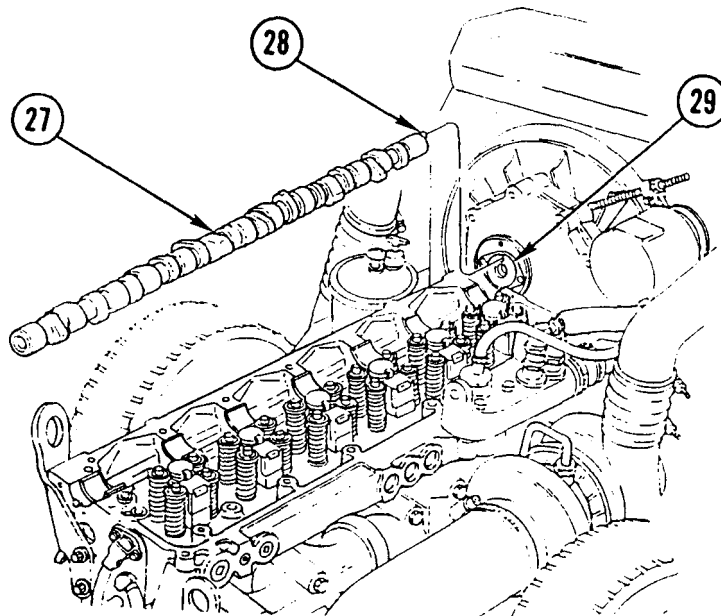

WARNING

Camshaft weighs 53 lb (24 kg). Attach suitable lifting device prior to removal to prevent possible injury to personnel.

CAUTION

Due to size and bulk of camshaft, care must be taken and two persons should be used to lift camshaft. Use non-metallic sling positioned inboard of camshaft bearings No. 1 and No. 7 to prevent damage to equipment.

17. USING SLINGS, SLIDE CAMSHAFT (27) TOWARD REAR TO DISENGAGE DOWEL (28) FROM CAMSHAFT DRIVE GEAR HUB (29). REMOVE CAMSHAFT (27).

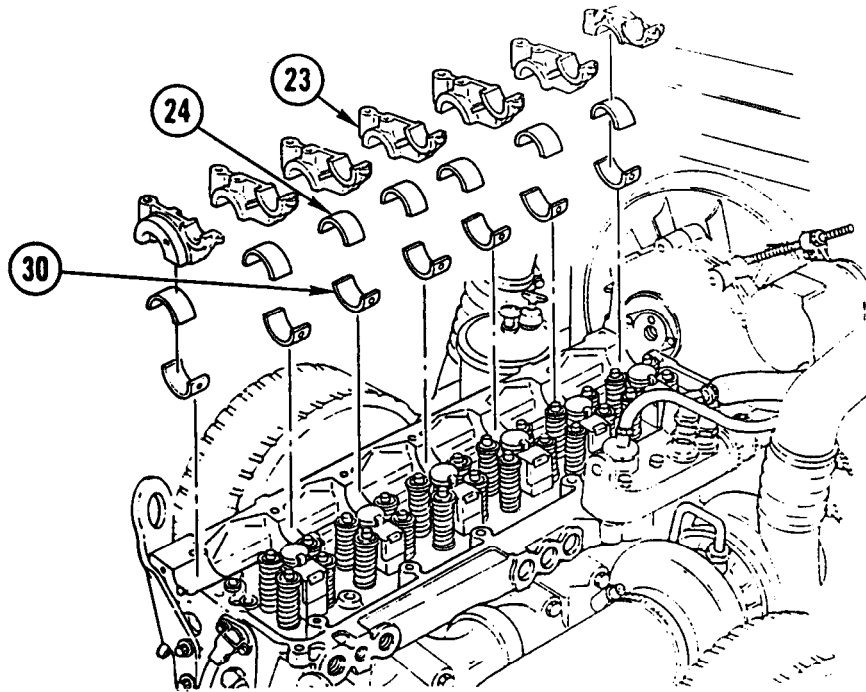

CAUTION

Upper and lower bearing shells are in sets and cannot be interchanged. If either upper or lower bearing is replaced, upper and lower bearing shells must also be replaced to prevent damage to equipment.

18. REMOVE SEVEN LOWER CAMSHAFT BEARING SHELLS (30). KEEP LOWER BEARING SHELLS (30) WITH THEIR CORRESPONDING UPPER CAMSHAFT BEARING SHELLS (24) AND CAMSHAFT BEARING CAPS (23).

WARNING

Adhesives, solvents, and sealing compounds can burn easily, can give off harmful vapors, and are harmful to skin and clothing. To avoid injury or death, keep away from open fire and use in well-ventilated area. If adhesive, solvent, or sealing compound gets on skin or clothing, wash immediately with soap and water.

1. CLEAN ALL REMOVED PARTS IN CLEAN SOLVENT.

CAMSHAFT AND BEARINGS REPLACEMENT (CONT)

WARNING

To prevent injury, compressed air will not exceed 30 psi (207 kPa). Use only with effective chip guarding and personal protective equipment, goggles, shield, and gloves.

2. MAKE SURE ALL OIL PASSAGES ARE CLEAR. DRY WITH COMPRESSED AIR.
3. USE GENERAL CLEANING METHODS TO CLEAN ALL PARTS (PAGE 2-30).

INSPECTION

1. INSPECT CAMSHAFT LOBES AND JOURNALS FOR SCORING, PITTING, OR FLAT SPOTS. IF CAMSHAFT IS SCORED, INSPECT CAMSHAFT FOLLOWER ROLLERS.

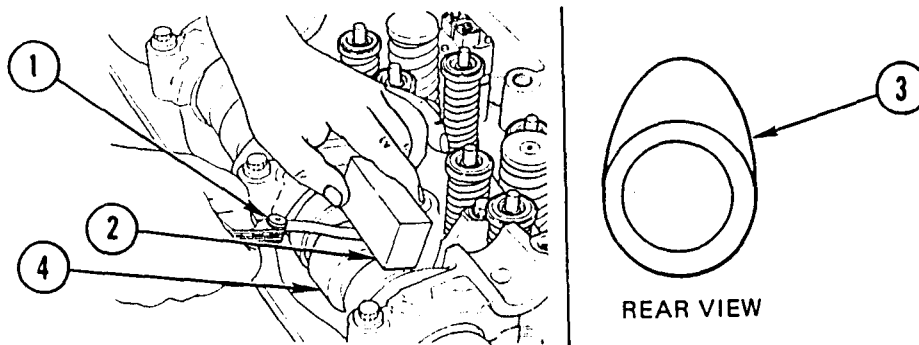

2. IF THERE IS DOUBT OF CAMSHAFT ACCEPTABILITY, DETERMINE EXTENT OF CAMSHAFT LOBE WEAR AS FOLLOWS:
 - A. USING SET OF 0.015-0.010-IN. (0.038-0.254-mm) FEELER GAGES (1) AND PIECE OF SQUARE, HARD MATERIAL (2), MEASURE FLATS ON INJECTOR RISE SIDE (3) OF CAMSHAFT LOBES (4).
 - B. IF FLATS MEASURE LESS THAN 0.003 IN. (0.076 mm) IN DEPTH, BUT THERE ARE NO OTHER CAMSHAFT DEFECTS, CAMSHAFT IS SATISFACTORY.

NOTE

If one camshaft bearing needs replacement, replace all camshaft bearing shells.

- c. INSPECT CAMSHAFT BEARINGS FOR SIGNS OF EXCESSIVE WEAR, SCORING, OR PITTING.
- D. DETERMINE CAMSHAFT BEARING CLEARANCE:

NOTE

Make sure locating tangs are correctly positioned.

- (1) WITH LOWER CAMSHAFT BEARING SHELLS INSTALLED IN CYLINDER HEAD, INSTALL CAMSHAFT (5) ON SEVEN CAMSHAFT BEARINGS.
- (2) INSTALL SEVEN UPPER CAMSHAFT BEARING SHELLS (6) IN SEVEN CAMSHAFT BEARING CAPS (7).

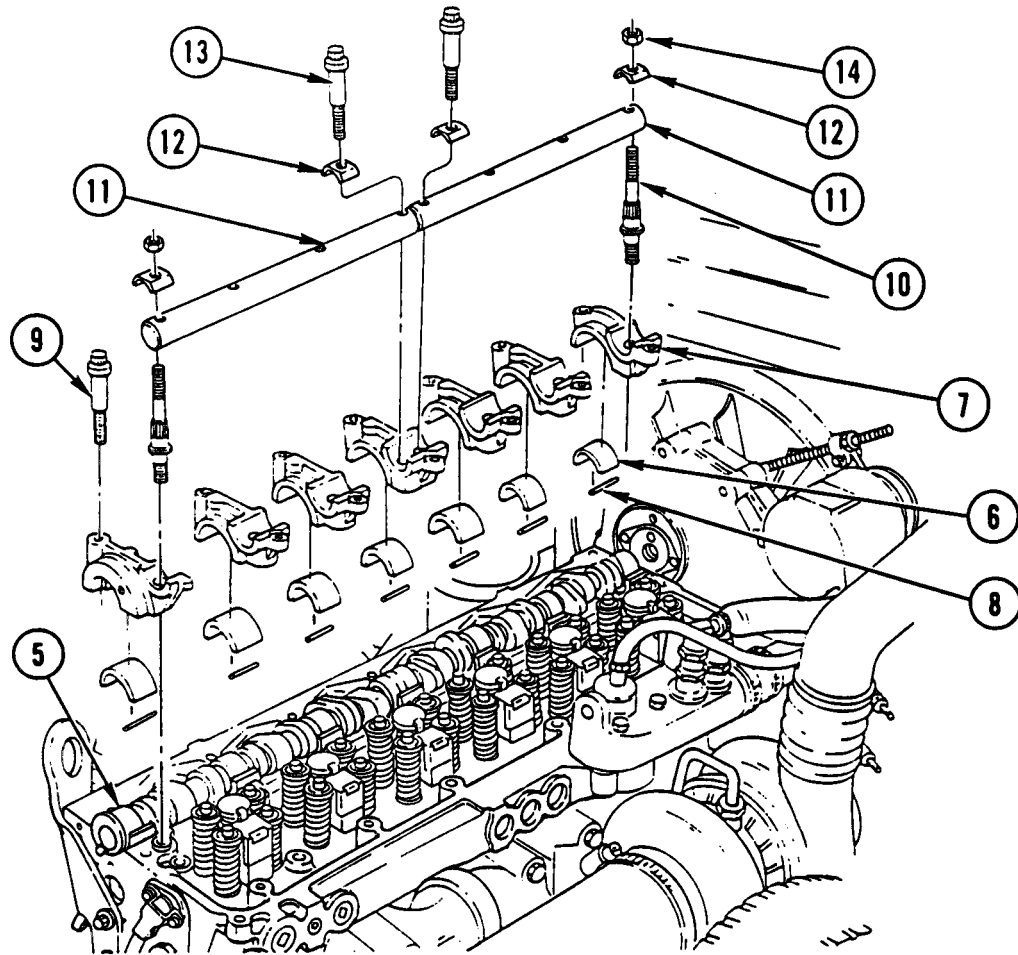

- (3) WIPE ANY OIL FROM CAMSHAFT BEARING SHELLS AND CAMSHAFT JOURNALS.
- (4) PLACE PIECE OF PLASTIGAUGE (8) FULL WIDTH OF EACH UPPER CAMSHAFT BEARING SHELL (6) ABOUT 1/4 IN. (6-7 mm) OFF CENTER.
- (5) INSTALL CAMSHAFT BEARING CAPS (7) AND CAMSHAFT BEARING SHELLS ON CORRECT CAMSHAFT JOURNALS AND INSTALL SEVEN CAMSHAFT CAP BOLTS (9). TIGHTEN BOLTS TO 75-86 LB-FT (101-116 N.m).
- (6) INSTALL TWO ROCKER SHAFT STUDS (10) IN CAMSHAFT BEARING CAPS (7) NO. 1 AND NO. 7. TIGHTEN STUDS TO 75-86 LB-FT (101-116 N.m).
- (7) INSTALL TWO ROCKER SHAFTS (11) ON SEVEN CAMSHAFT BEARING CAPS (7).
- (8) INSTALL EIGHT ROCKER SHAFT SADDLE WASHERS (12), SIX BOLTS (13), AND TWO NUTS (14). TIGHTEN BOLTS AND NUTS TO 75-86 LB-FT (101-116 N.m).
- (9) REMOVE TWO ROCKER SHAFT NUTS (14), SIX BOLTS (13), EIGHT SADDLE WASHERS (12), AND TWO ROCKER SHAFTS (11).
- (10) REMOVE TWO ROCKER SHAFT STUDS (10).
- (11) REMOVE SEVEN OUTBOARD CAMSHAFT CAP BOLTS (9), SEVEN CAMSHAFT CAPS (7), AND SEVEN BEARING SHELLS (6).

CAMSHAFT AND BEARINGS REPLACEMENT (CONT)

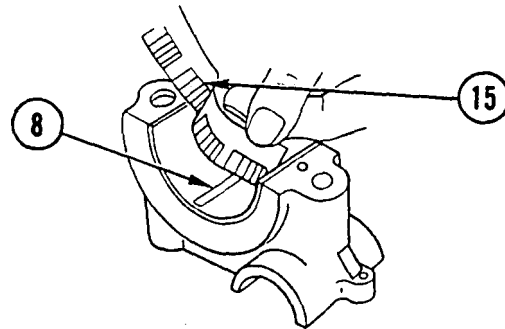

NOTE

- Flattened plastigauge will adhere to either bearing shell or camshaft journal.
- Maximum camshaft journal-to-bearing clearance is 0.0035-0.0065 in. (0.09-0.166 mm); maximum is 0.0075 in. (191 mm) with used parts.

(12) COMPARE WIDTH OF PLASTIGAUGE (8) AT WIDEST POINT WITH GRADUATION SCALE (15) ON PLASTIGAUGE ENVELOPE TO DETERMINE BEARING CLEARANCE.

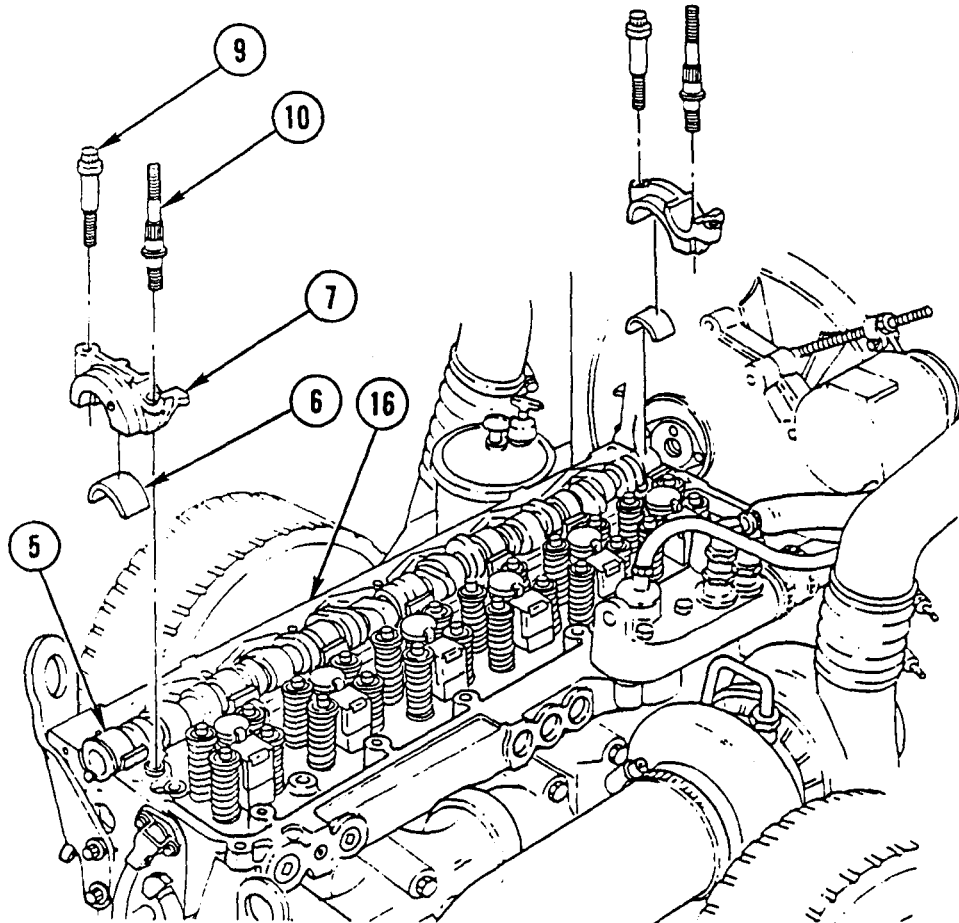

WARNING

Camshaft weighs 53 lb (24 kg). Attach suitable lifting device prior to removal to prevent possible injury to personnel.

- E. REMOVE CAMSHAFT (5).
- F. REMOVE LOWER HALF OF BEARING SHELLS (6), NO.2 THRU NO. 6.

NOTE

Make sure locating tangs are correctly positioned.

- G. LUBRICATE TWO UPPER AND TWO LOWER CAMSHAFT BEARING SHELLS (6) NO. 1 AND NO. 7 WITH CLEAN ENGINE LUBRICATING OIL AND INSTALL IN TWO RESPECTIVE CAMSHAFT BEARING CAPS (7).
- H. INSTALL CAMSHAFT (5).
- I. INSTALL TWO CAMSHAFT BEARING CAPS (7) NO. 1 AND NO. 7 IN CYLINDER HEAD (16) AND INSTALL TWO CAMSHAFT CAP BOLTS (9) AND TWO ROCKER SHAFT STUDS (10) IN TWO CAMSHAFT BEARING CAPS (7) NO. 1 AND NO. 7. TIGHTEN BOLTS AND STUDS TO 75-86 LB-FT (101-116 N.m). USE ROCKER STUD SOCKET TO TIGHTEN STUDS.

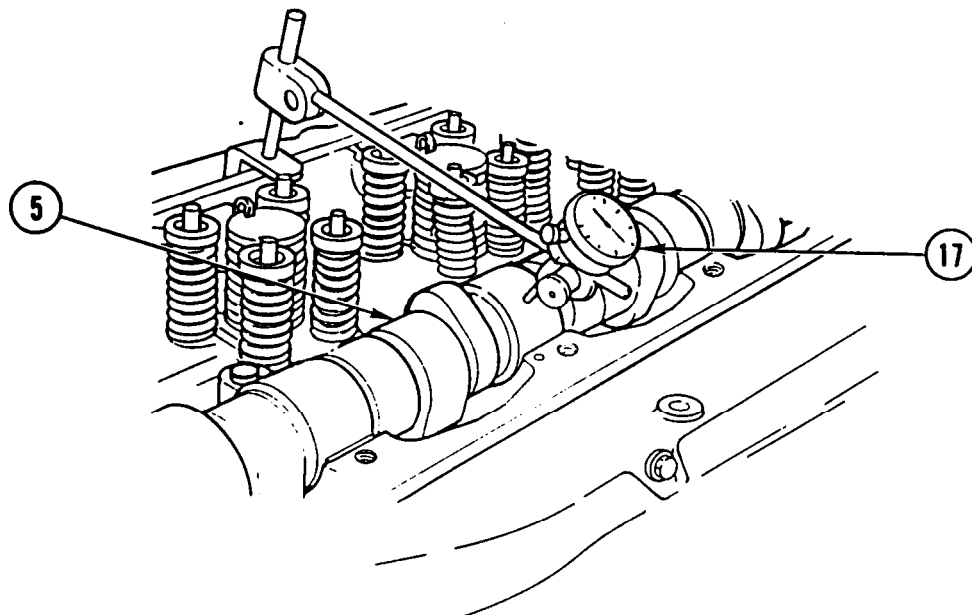
**NOTE**

If camshaft runout exceeds 0.002 in. (0.050 mm), replace camshaft.

- J. USING DIAL INDICATOR (17), CHECK RUNOUT OF CAMSHAFT (5) AT BEARING JOURNAL NO. 4.
- K. REMOVE TWO CAMSHAFT BEARING CAPS (7) NO 1. AND NO. 7 FROM CYLINDER HEAD (16).
- L. REMOVE CAMSHAFT (5).

CAMSHAFT AND BEARINGS REPLACEMENT (CONT)

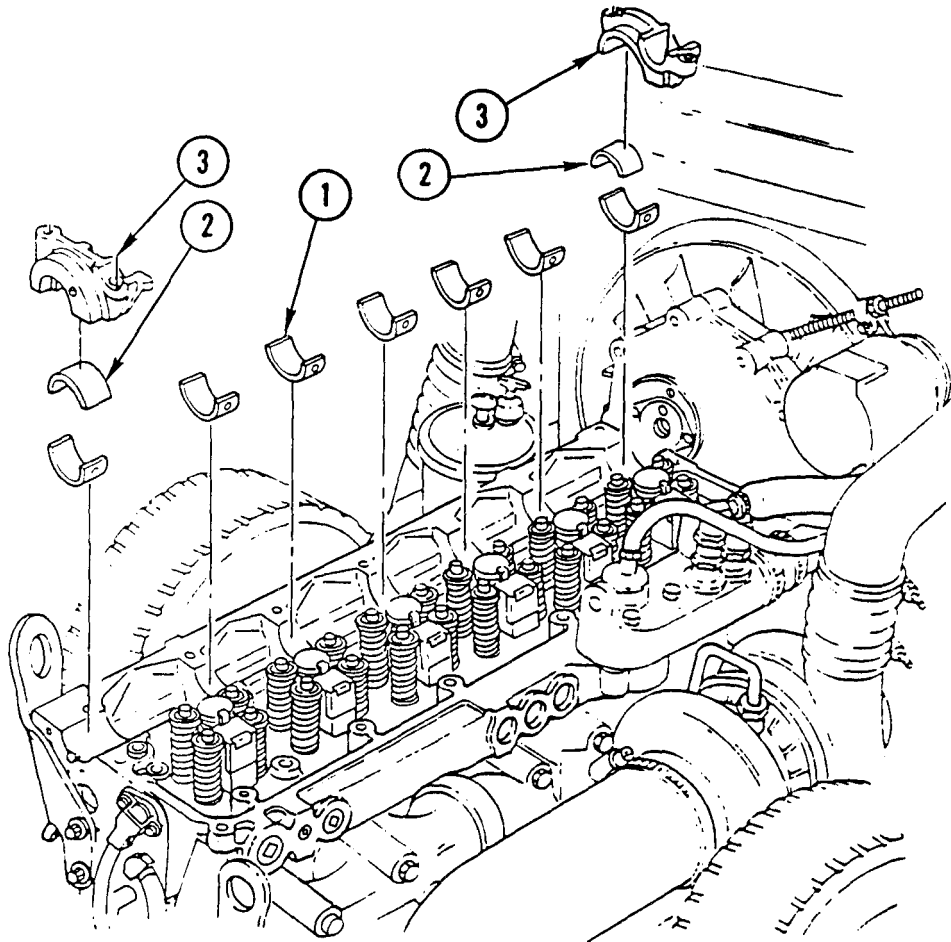

NOTE

If new bearings are installed, replace upper and lower bearing shells as sets. Note position of oil holes and locating tangs.

1. INSTALL SEVEN LOWER BEARING SHELLS (1) IN CYLINDER HEAD AND LUBRICATE CAMSHAFT BEARING SHELLS (1) WITH CLEAN ENGINE LUBRICATING OIL.
2. INSTALL TWO UPPER CAMSHAFT BEARING SHELLS (2) IN CAMSHAFT BEARING CAPS (3) NO. 1 AND NO. 7. LUBRICATE CAMSHAFT BEARING SHELLS (2) WITH CLEAN ENGINE LUBRICATING OIL.

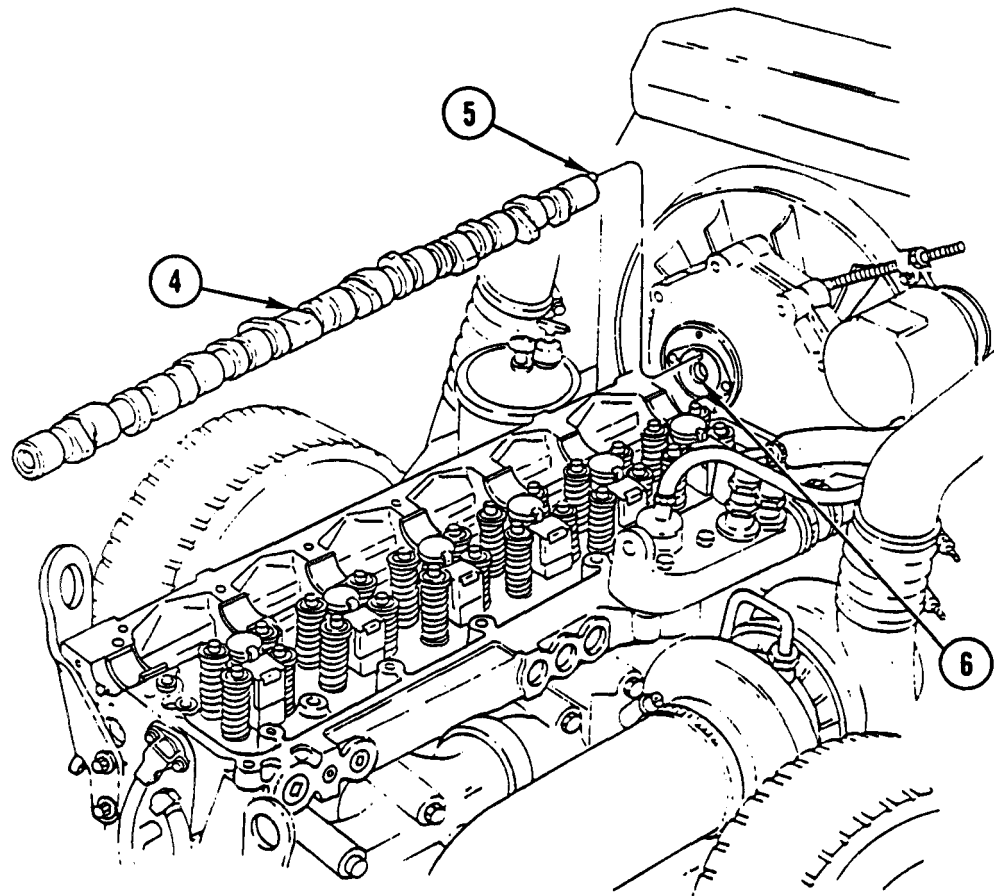

NOTE

If new camshaft is installed, steam clean to remove rust preventive and blow dry with compressed air. Make sure dimple in thrust plate is located at 12 o'clock position before installing camshaft dowel in camshaft drive gear hub.

3. LUBRICATE CAMSHAFT LOBES AND JOURNALS WITH CLEAN ENGINE LUBRICATING OIL.

WARNING

Camshaft weighs 53 lb (24 kg), Attach suitable lifting device prior to installation to prevent possible injury to personnel.

4. USING NON-METALLIC SLING, LOWER CAMSHAFT (4) INTO POSITION AND SLIDE FORWARD, MAKING SURE CAMSHAFT DOWEL (5) ALINES WITH MATING HOLE IN CAMSHAFT DRIVE GEAR HUB (6). THIS WILL POSITION CAMSHAFT BEARING JOURNALS IN LOWER CAMSHAFT BEARING SHELLS.

CAMSHAFT AND BEARINGS REPLACEMENT (CONT)

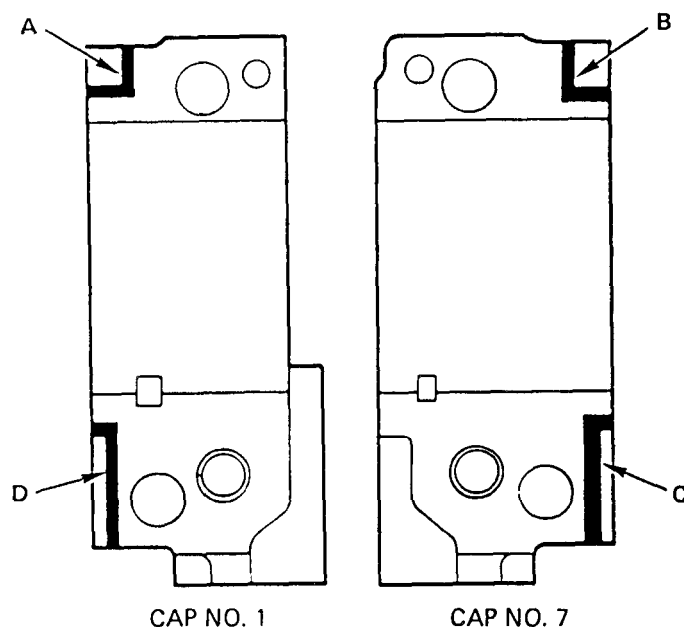

CAUTION

Be careful not to get gasket eliminator on camshaft bearing shell seats and bearing surfaces. Keep time to minimum between installation of camshaft bearing caps no. 1 and no. 7 and tightening of camshaft cap bolts and nuts. Make sure two seal rings are placed on cylinder head before assembling camshaft bearing caps to cylinder head. Failure to do so could result in damage to equipment.

NOTE

Make sure locating tangs are correctly positioned.

5. APPLY THIN BEAD OF GASKET ELIMINATOR TO JOINT FACE SURFACES (A, B, C, AND D) OF TWO CAMSHAFT BEARING CAPS NO. 1 AND NO. 7.

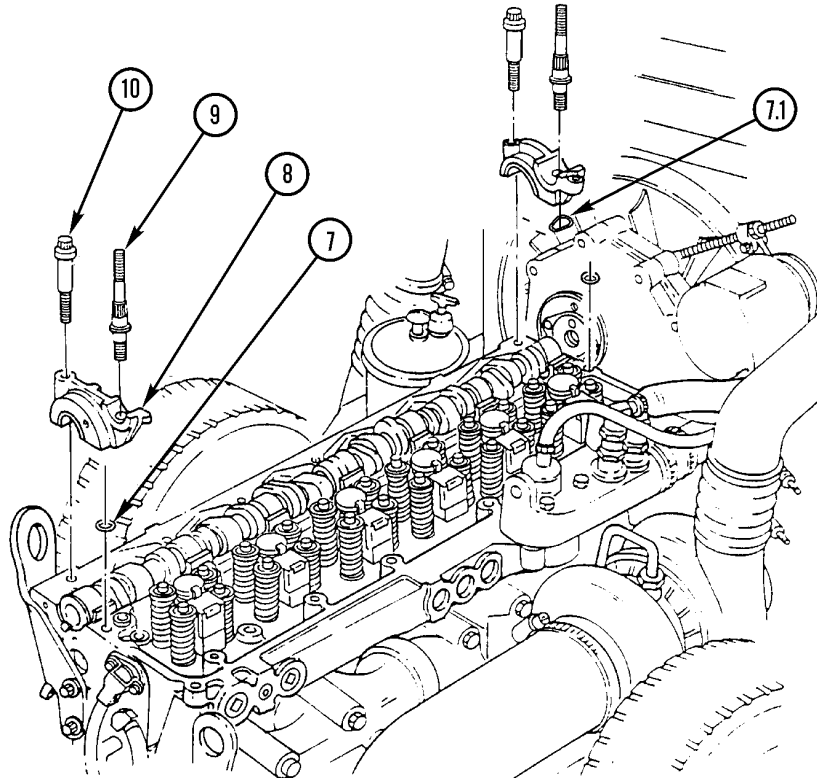

6. INSTALL TWO NEW SEAL RINGS (7) IN COUNTERBORES UNDER TWO CAMSHAFT BEARING CAPS (8) NO. 1 AND NO. 7.
7. INSTALL TWO CAMSHAFT BEARING CAPS (8), NO. 1 AND NO. 7, WITH BEARING SHELLS IN PLACE.
- 7.1 INSTALL RACETRACK SEAL (7.1) ON CAMSHAFT BEARING CAP (8) NO. 7.
8. TIGHTEN TWO ROCKER SHAFT STUDS (9) AND TWO CAMSHAFT CAP BOLTS (10) ON TWO CAMSHAFT BEARING CAPS (8) NO. 1 AND NO. 7 TO 75-86 LB-FT (101-116 N.m). USE ROCKER STUD SOCKET TO TIGHTEN STUDS.

CAMSHAFT AND BEARINGS REPLACEMENT (CONT)

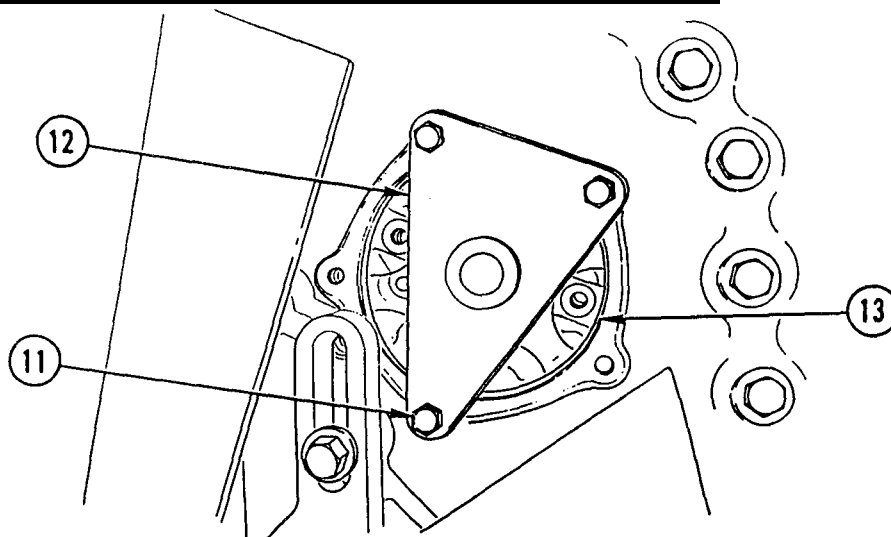

9. REMOVE THREE BOLTS (11) AND CAMSHAFT GEAR PILOT (12) FROM CAMSHAFT DRIVE GEAR ACCESS OPENING (13).

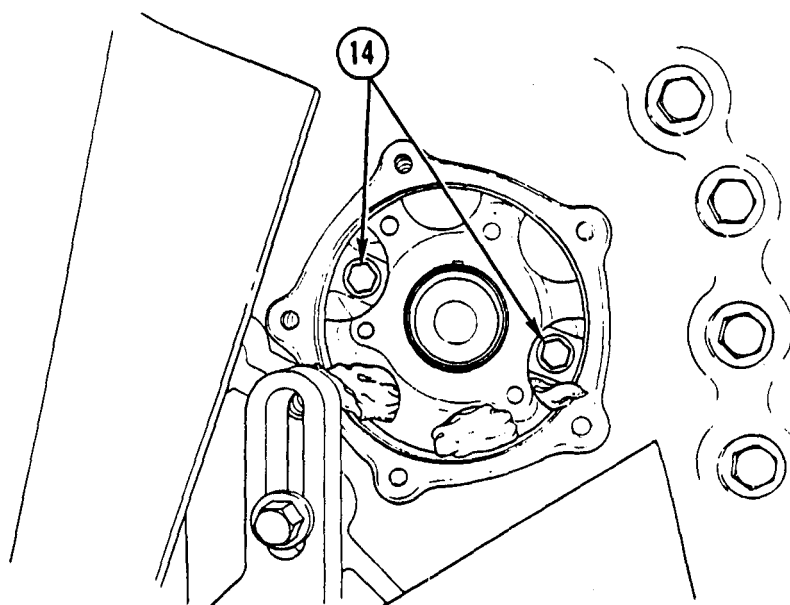

CAUTION

Clean shop towel may be inserted into gear housing assembly opening to trap bolts in case they are dropped. Do not allow towel to drop into gear housing assembly to prevent damage to equipment.

NOTE

Make sure camshaft, dowel is engaged.

10. INSTALL TWO BOLTS (14), TIGHTEN BOLTS ALTERNATELY TO DRAW THRUST PLATE STRAIGHT INTO GEAR HOUSING ASSEMBLY. TIGHTEN BOLTS TO 22-28 LB-FT (30-38 N.m).

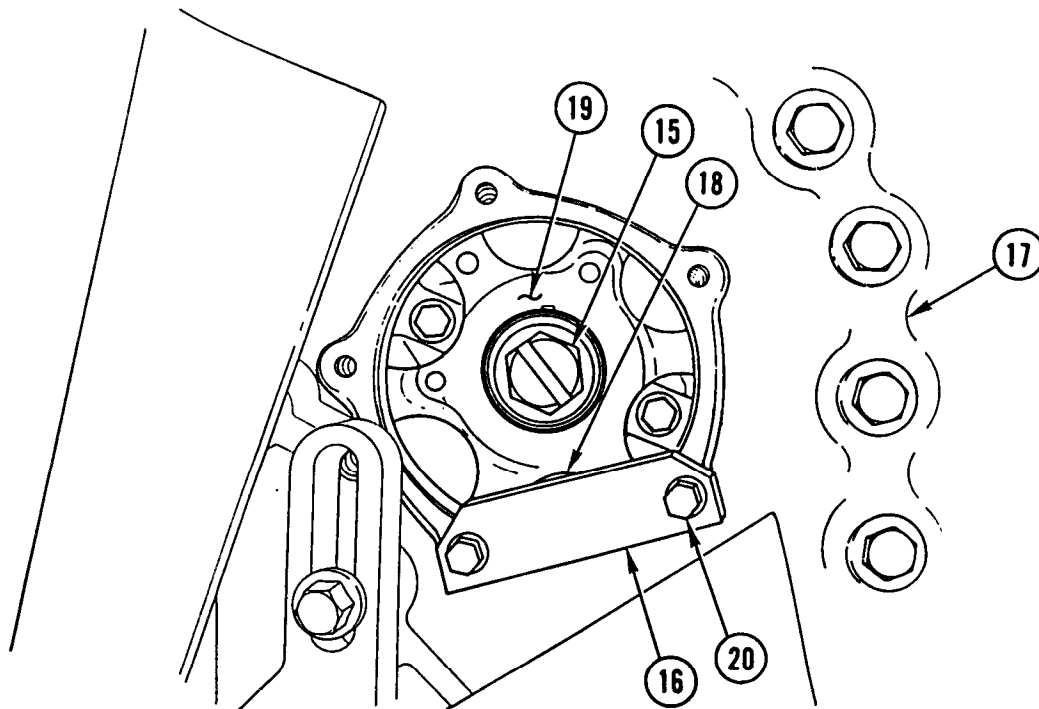

CAUTION

Camshaft should be held in place while installing camshaft drive gear bolt to prevent disengaging camshaft dowel from drive gear hub.

11. COAT THREADS AND UNDERSIDE HEAD OF CAMSHAFT DRIVE GEAR BOLT (15) WITH INTERNATIONAL COMPOUND N0.2. AND INSTALL BOLT HAND-TIGHT.

NOTE

After inserting shoe of camshaft drive gear retaining tool thru access hole of camshaft drive gear, it may be necessary to bar engine over slightly to aline bolt holes in retaining tool with bolt holes in drive gear access cover.

12. INSTALL CAMSHAFT DRIVE GEAR RETAINING TOOL (16) ON GEAR HOUSING (17) ENGAGING ONE OF ACCESS HOLES (18) IN CAMSHAFT DRIVE GEAR (19). INSTALL TWO BOLTS (20) IN RETAINING TOOL AND GEAR HOUSING.
13. TIGHTEN CAMSHAFT DRIVE GEAR BOLT (15) TO 225-257 LB-FT (305-348 N.m).
14. REMOVE TWO BOLTS (20) AND CAMSHAFT DRIVE GEAR RETAINING TOOL (16).

CAMSHAFT AND BEARINGS REPLACEMENT (CONT)

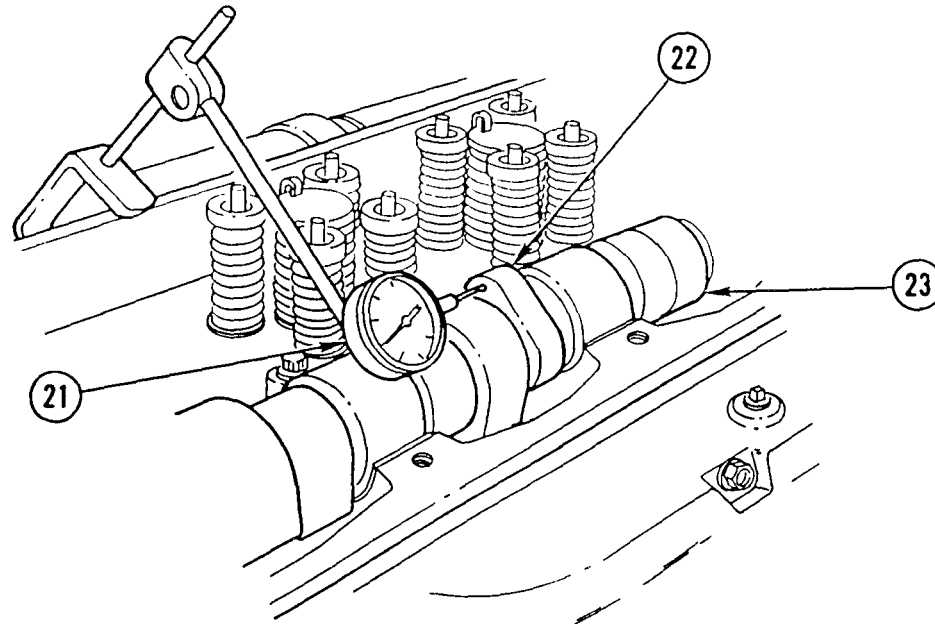

15. USING DIAL INDICATOR (21), PLACE POINTER IN CONTACT WITH SIDE OF CAMSHAFT LOBE (22).
16. MOVE CAMSHAFT (23) AS FAR FORWARD AS POSSIBLE. HOLD IN THAT POSITION AND ZERO DIAL INDICATOR (21).
17. MOVE CAMSHAFT (23) TO REAR AS FAR AS POSSIBLE. READ AND RECORD TOTAL AMOUNT OF END PLAY. ALLOWABLE CAMSHAFT END PLAY IS 0.003-0.015 IN. (0.076-0.381 mm).
18. IF END PLAY IS BEYOND MAXIMUM LIMIT, REMOVE AND REPAIR OR REPLACE CAMSHAFT DRIVE GEAR ASSEMBLY (PAGE 12-61).

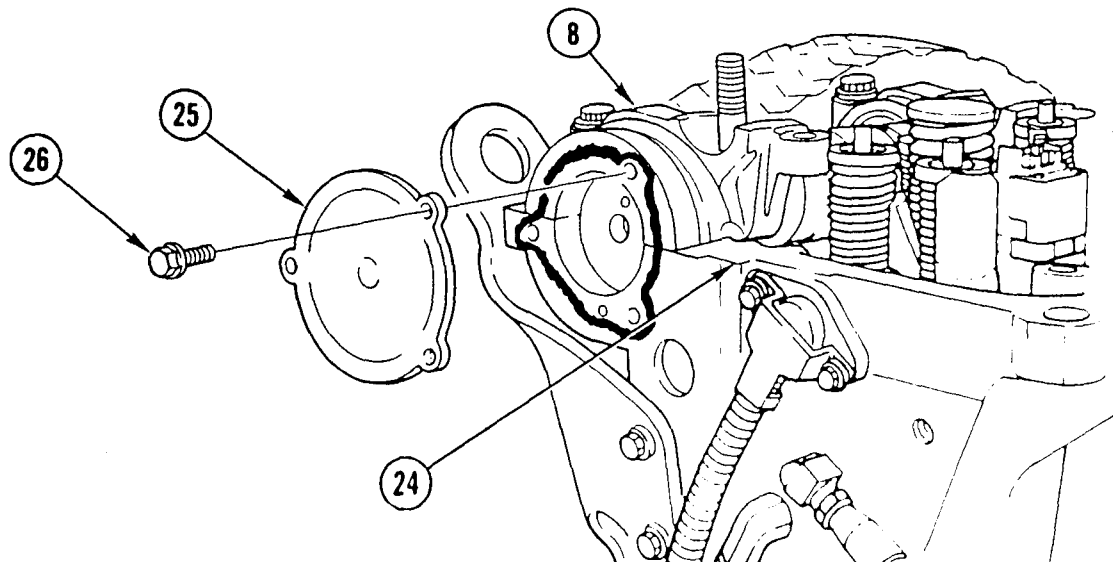

NOTE

- Make sure all old gasket eliminator has been removed from rear camshaft cover and camshaft bearing cap no. 7 mating surfaces.
 - If performing step 19 in vehicle, gasket eliminator is to be applied to cover.
19. APPLY THIN BEAD OF GASKET ELIMINATOR TO CAMSHAFT BEARING CAP (8) NO. 7 MATING SURFACE AND INSTALL CAMSHAFT BEARING CAP (8) NO. 7 ON CYLINDER HEAD (24).
 20. INSTALL REAR CAMSHAFT COVER (25) AND THREE BOLTS (26). TIGHTEN BOLTS TO 22-28 LB-FT (30-38 N.m).

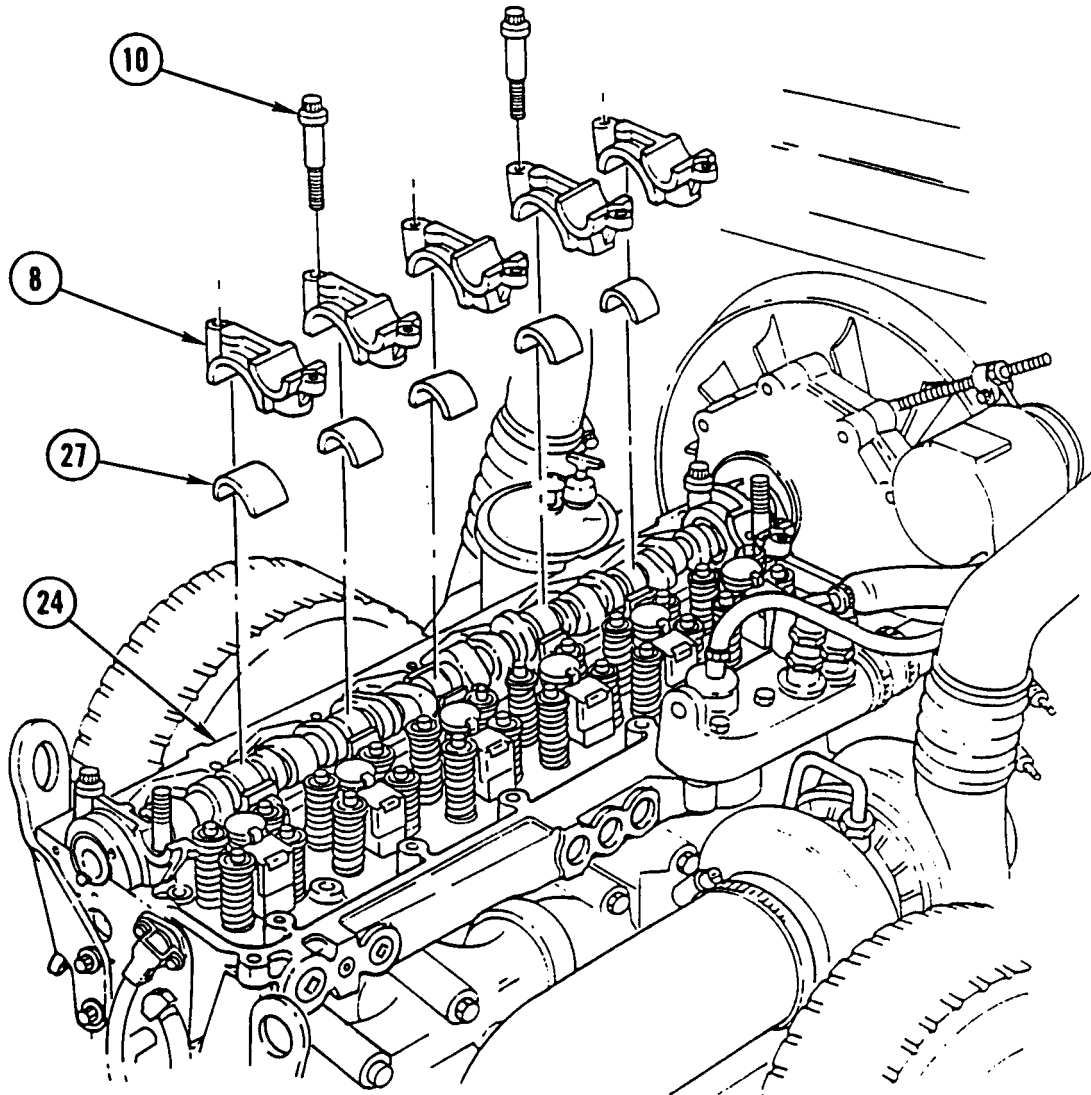

NOTE

Make sure locating tangs are correctly positioned.

21. INSTALL FIVE CAMSHAFT BEARING SHELLS (27) IN CAMSHAFT BEARING CAPS (8) NO. 2, NO. 3, NO. 5, AND NO. 6. LUBRICATE.
22. INSTALL FIVE CAMSHAFT BEARING CAPS (8) ON CORRECT SADDLES ON CYLINDER HEAD (24) AND INSTALL TWO CAMSHAFT CAP BOLTS (10) HAND-TIGHT IN CAMSHAFT BEARING CAPS NO. 3 AND NO. 5.

CAMSHAFT AND BEARINGS REPLACEMENT (CONT)

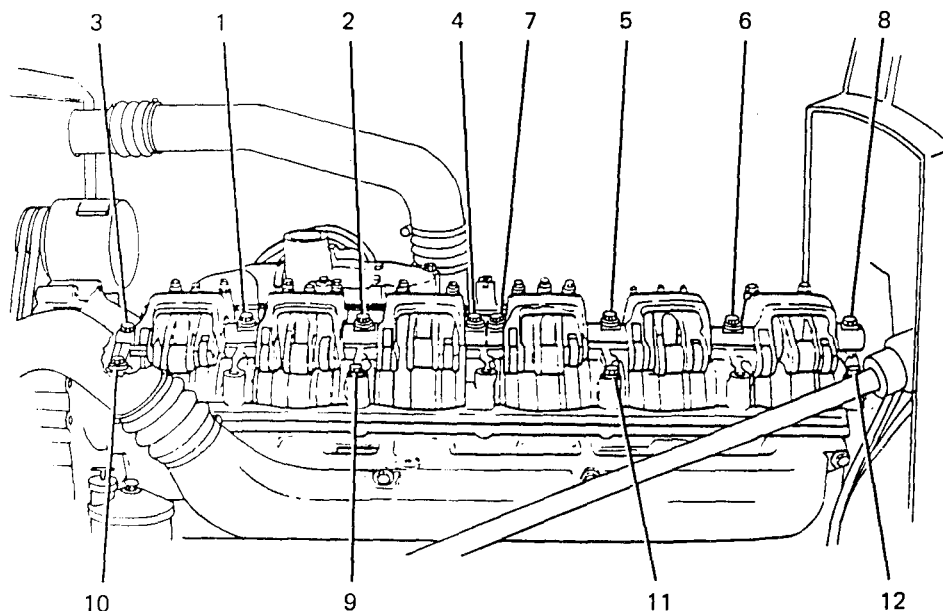

23. INSTALL ROCKER ARM ASSEMBLIES (PAGE 3-183).

24. TIGHTEN 12 CAMSHAFT CAP AND ROCKER ARM BOLTS AND NUTS TO 75-86 LB-FT (101-116 N.m) IN SEQUENCE SHOWN.

NOTE

Follow-on Maintenance:

Install tachometer drive (TM 9-2320-363-20).

Install engine retarder (page 3-129).

ROCKER ARM ASSEMBLIES REPLACEMENT

This task covers: a. Removal b. Cleaning c. Inspection d. Installation e. Adjustment

INITIAL SETUP

Tools and Special Equipment:

- Shop Equipment, SC 4910-95-CL-A31
- Tool Kit, SC 5180-90-CL-N05
- Rocker Arm Lifter, J35996
- Rocker Stud Socket, J36003
- Injector Timing Height Gauge, J35637-A (DDEC II)
- Injector Timing Height Gauge, J39697 (DDEC III)
- Valve Button Expander, J36347
- Cup Plug Installer, J36326

Materials/Parts:

- Plug, Cup (2) P/N 9421745
- Rags Appendix B, Item 48
- Solvent, Drycleaning Appendix B, Item 20
- Oil, Lubricating Appendix B, Item 37

Equipment Condition:

Reference	Condition Description
Page 3-129	Engine Retarder Removed

General Safety Instructions:

WARNING

To prevent injury, compressed air will not exceed 30 psi (207 kPa). Use only with effective chip guarding and personal protective equipment, goggles, shield, and gloves.

ROCKER ARM ASSEMBLIES REPLACEMENT (CONT)

REMOVAL

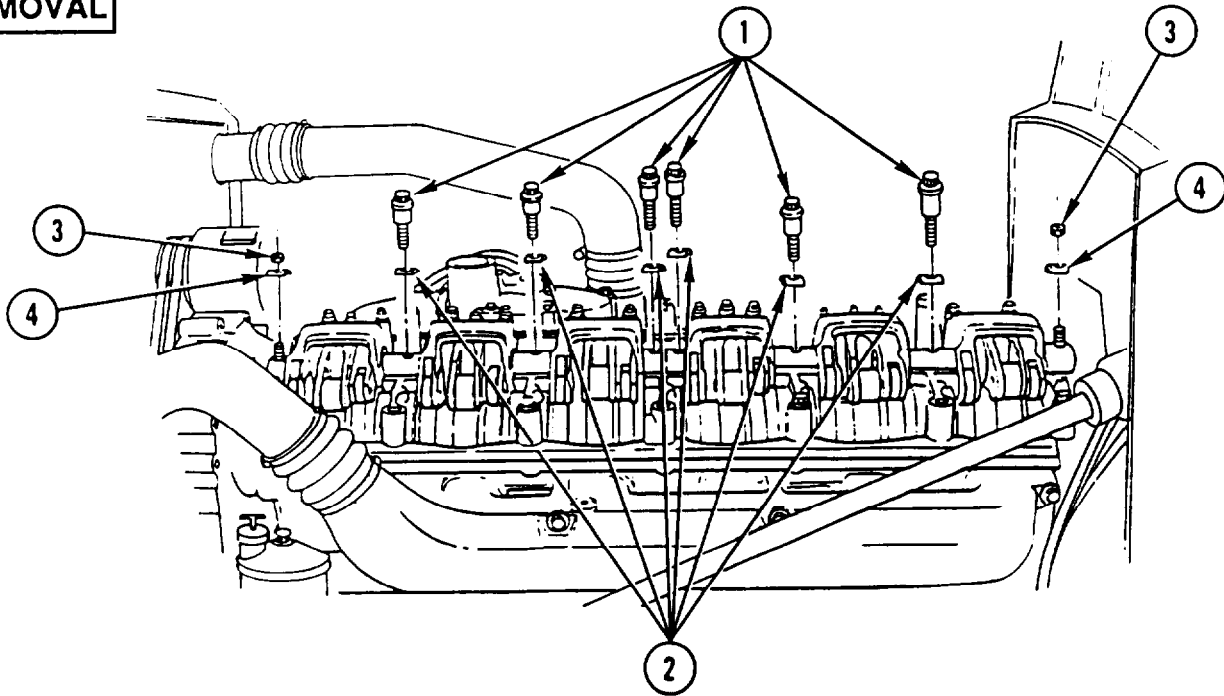

CAUTION

Failure to follow procedures below could result in damage to rocker arm shaft.

1. IN ONE-TURN INCREMENTS, REMOVE SIX RETAINING BOLTS (1) AND SIX SADDLE SPACERS (2).
2. REMOVE TWO NUTS (3) AND TWO SADDLE SPACERS (4).

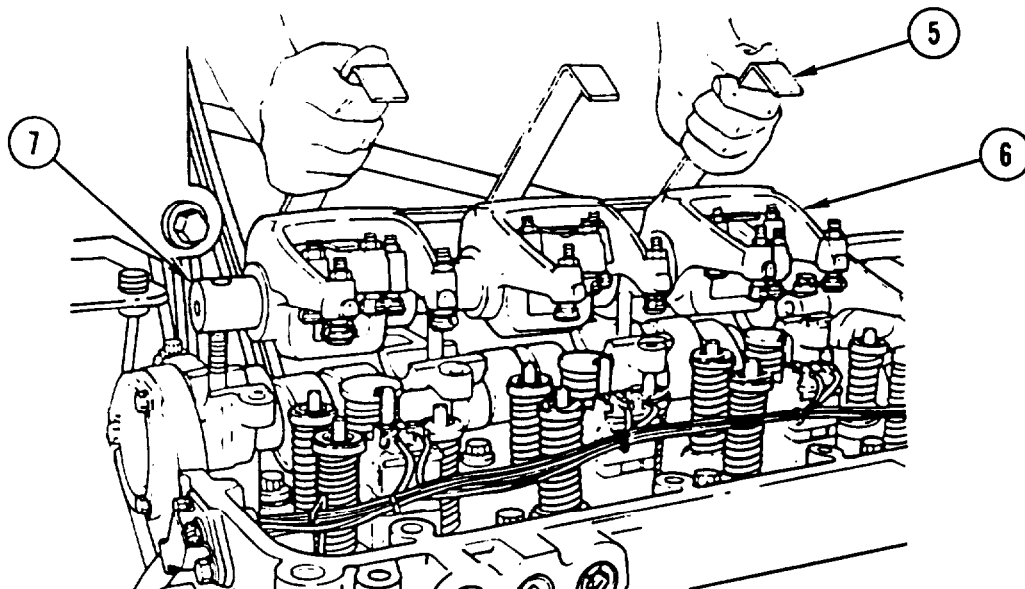

NOTE

- Position lifter fingers under cross arch of exhaust rocker arm assembly (above center section of injector rocker assembly). Lifter fingers fit between intake and injector rockers.
 - Tag rocker arm assemblies by cylinder location prior to removal to aid in installation.
3. USING ROCKER ARM LIFTER (5) ON ROCKER ARM ASSEMBLIES (6) FROM CAM ROLLER SIDE, LIFT ROCKER ARM ASSEMBLIES AND ROCKER ARM SHAFT (7) FROM CYLINDER HEAD.

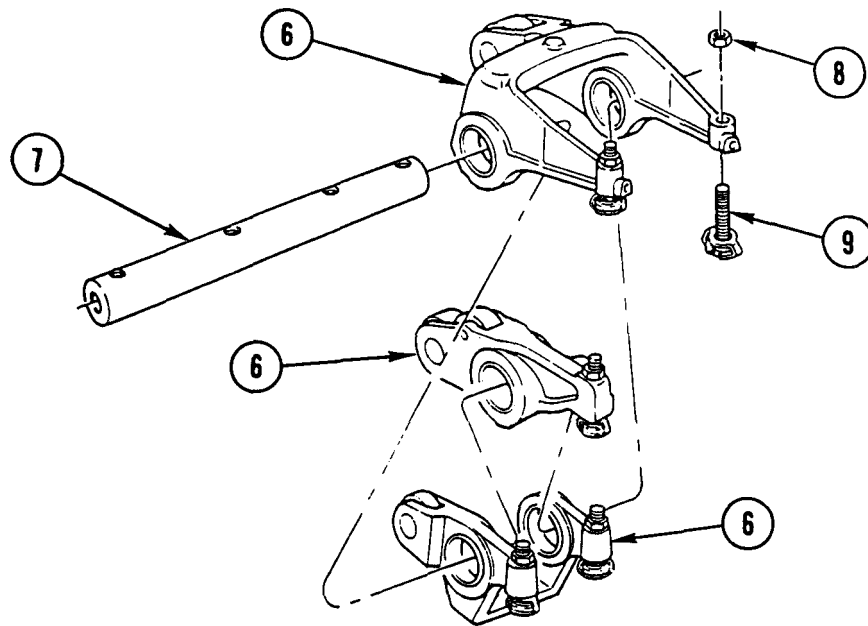

4. SLIDE ROCKER ARM ASSEMBLIES (6) OFF ROCKER ARM SHAFT (7).
5. REMOVE JAM NUTS (8) AND ADJUSTING SCREWS (9) FROM EACH ROCKER ARM ASSEMBLY (6).

ROCKER ARM ASSEMBLIES REPLACEMENT (CONT)

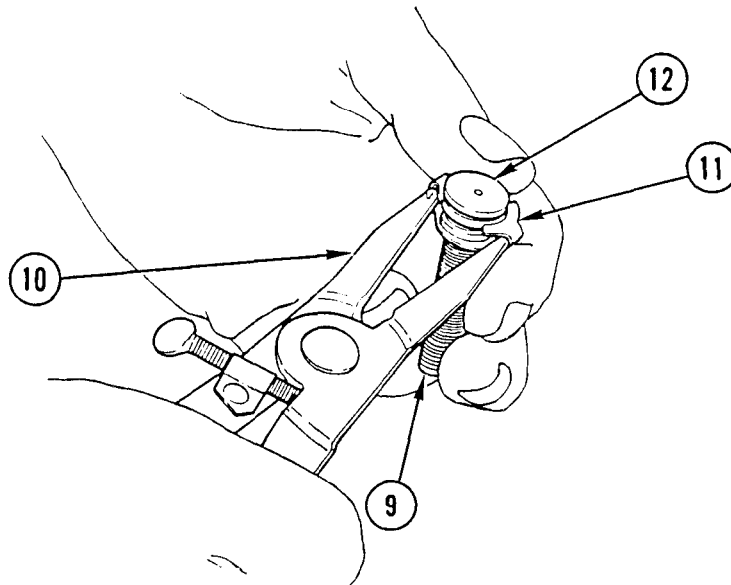

CAUTION

Do not expand retaining clip more than 0.61 in. (15.50 mm) when removing intake valve button. To do so could result in damage to equipment.

6. HOLD ADJUSTING SCREW (9) AND WITH VALVE BUTTON EXPANDER (10) SPREAD LEGS OF RETAINING CLIP (11) AND REMOVE INTAKE VALVE BUTTON (12).
7. REMOVE RETAINING CLIP (11) FROM THREADED END OF ADJUSTING SCREW (9).

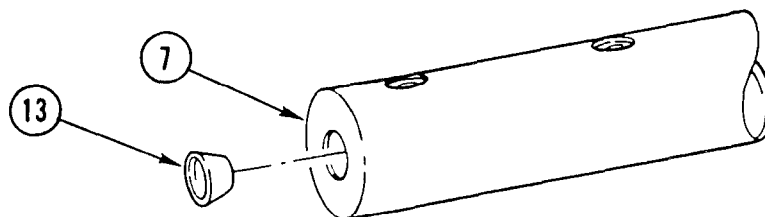

8. USING PIN PUNCH, PUNCH HOLE IN TWO CUP PLUGS (13) AT ENDS OF ROCKER ARM SHAFT (7). PRY TWO CUP PLUGS (13) FROM SHAFT (7). DISCARD CUP PLUGS.

CLEANING

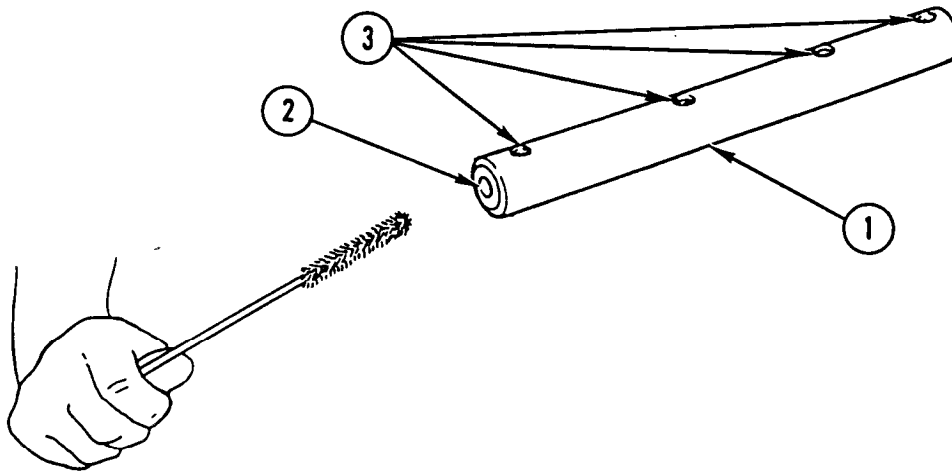

1. SOAK ROCKER ARM SHAFT (1) IN DRYCLEANING SOLVENT. RUN WIRE BRUSH THRU CENTER OIL PASSAGE (2).

WARNING

To prevent injury, compressed air will not exceed 30 psi (207 kPa). Use only with effective chip guarding and personal protective equipment, goggles, shield, and gloves.

2. BLOW OUT CENTER OIL PASSAGE (2) AND OIL HOLES (3) WITH COMPRESSED AIR. WIPE EXTERIOR WITH CLEAN, LINT-FREE RAGS.

INSPECTION

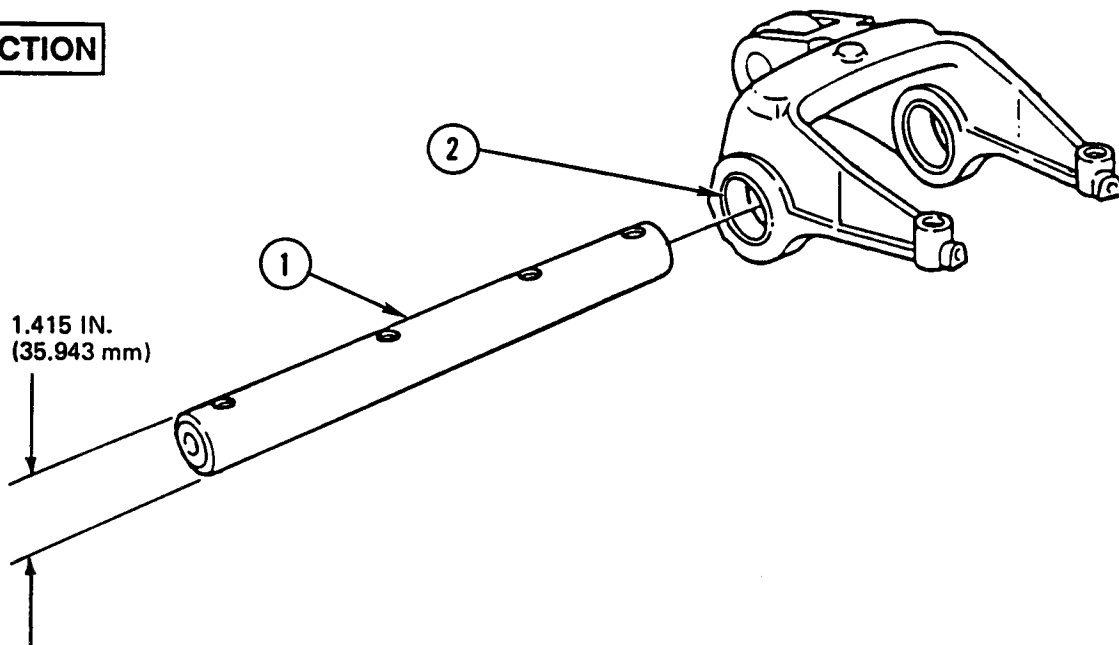

1. INSPECT ROCKER ARM SHAFT (1) WHERE CONTACT IS MADE WITH ROCKER ARM BUSHINGS (2). IF ROCKER ARM SHAFT (1) DIAMETER IS LESS THAN 1.415 IN. (35.943 mm) MINIMUM, REPLACE SHAFT.

ROCKER ARM ASSEMBLIES REPLACEMENT (CONT)

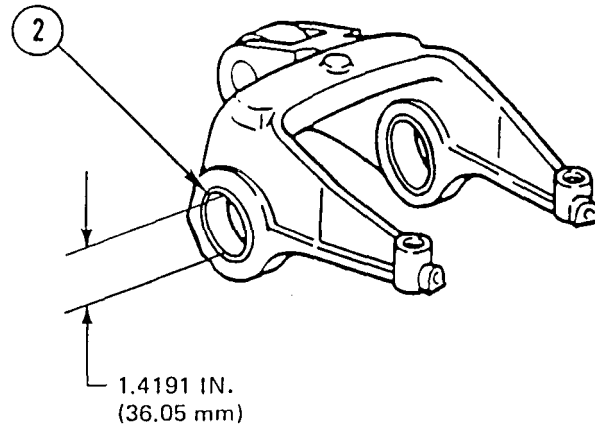

2. INSPECT ROCKER ARM BUSHINGS (2) FOR EXCESSIVE WEAR OR SCORING. MEASURE ROCKER ARM BUSHING (2) INSIDE DIAMETER. IF DIAMETER IS MORE THAN 1,4191 IN. (36.050 mm), REPLACE ROCKER ARM ASSEMBLY.

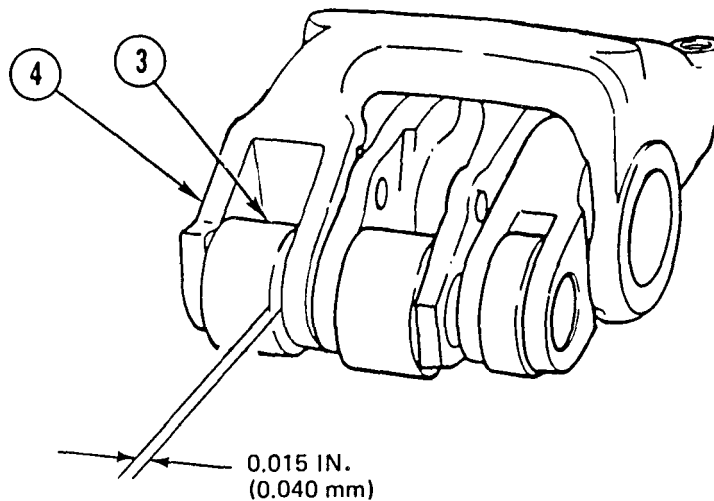

3. CHECK CAM FOLLOWER ROLLERS (3) FOR SCORING, PITTING, OR FLAT SPOTS. IF ANY OF THESE CONDITIONS ARE EVIDENT, REPLACE ROCKER ARM ASSEMBLY (4).
4. CHECK SIDE CLEARANCE BETWEEN ROLLER AND ROCKER ARM. IF MORE THAN 0.03 IN. (0.08 mm) MAXIMUM, REPLACE ROCKER ARM ASSEMBLY (4).
5. MAKE SURE CAM FOLLOWER ROLLER (3) TURNS FREELY ON ITS PIN. REPLACE ROCKER ARM ASSEMBLY (4) IF ROLLER DOES NOT TURN FREELY OR BINDS, OR IF THERE IS VERTICAL MOVEMENT BETWEEN ROLLER AND PIN.
6. CHECK ROCKER SHAFT ARM STUD FOR TIGHTNESS WHENEVER ROCKER ARM SHAFT IS LOOSENED OR REMOVED. MAKE SURE ROCKER SHAFT STUDS ARE TIGHTENED TO 75-86 LB-FT (101-116 N.m).

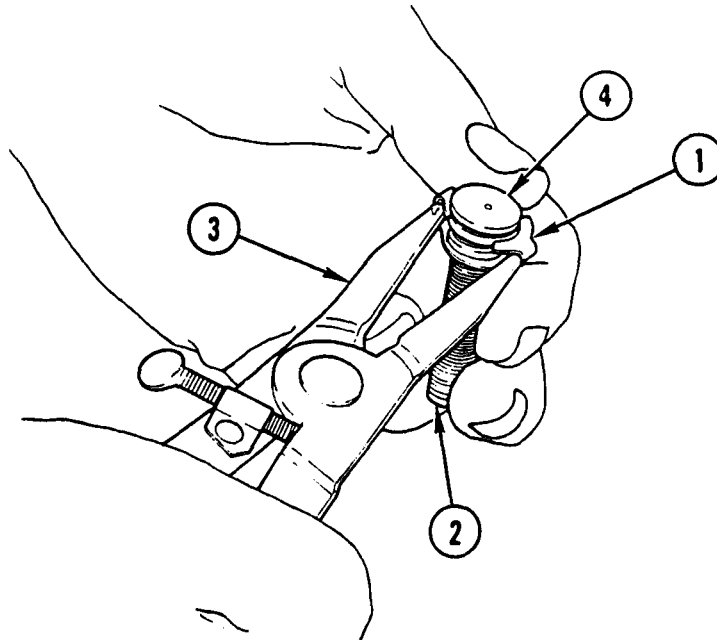
INSTALLATION**CAUTION**

Do not expand retaining clip more than 0.61 in. (15.50 mm) when installing retaining clip. To do so could result in damage to equipment.

NOTE

Position concave (dished side) of intake valve button toward adjusting screw ball.

1. SLIDE RETAINING CLIP (1), OPEN END FIRST, ONTO ADJUSTING SCREW (2). SPREAD RETAINING CLIP (1) SLIGHTLY, IF NECESSARY, SO OPEN END CAN PASS OVER BALL HEAD OF ADJUSTING SCREW (2).
2. INSERT TIPS OF VALVE BUTTON EXPANDER (3) BETWEEN LEGS OF RETAINING CLIP (1). EXPAND CLIP ENOUGH TO INSERT GROOVE ON INTAKE VALVE BUTTON (4) ONTO LEG ARCS OF RETAINING CLIP (1).

ROCKER ARM ASSEMBLIES REPLACEMENT (CONT)

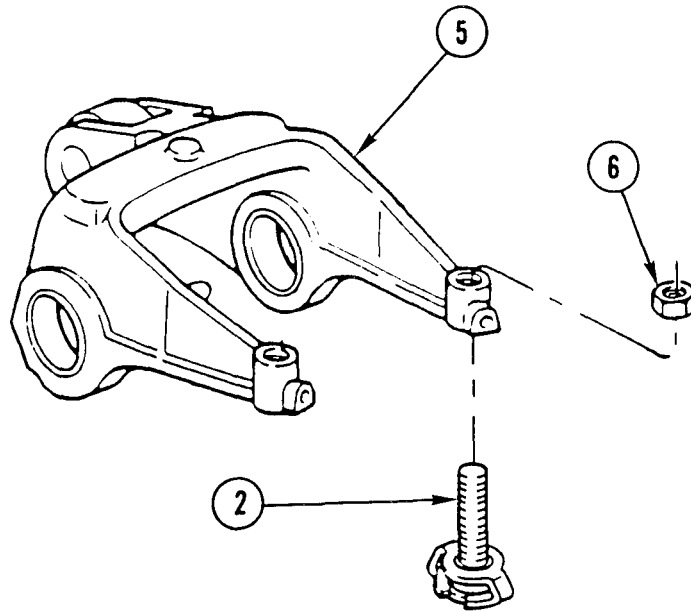

NOTE

- Adjusting screws with annular (Allen wrench) adjustment are used on intake (short arm) and injector rocker arm assemblies.
 - Hex head adjusting screws are used on exhaust (long arm) rocker arm assembly.
3. THREADJUSTING SCREW (2) INTO CORRECT ROCKER ARM (5) AND INSTALL JAM NUT (6)

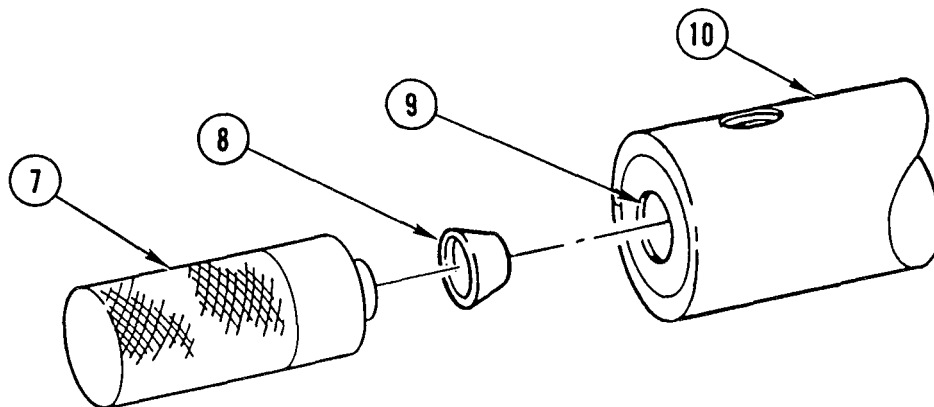

4. USING CUP PLUG INSTALLER (7), INSTALL NEW CUP PLUG (8) IN OIL PASSAGE (9) AT EACH END OF ROCKER ARM SHAFT (10).

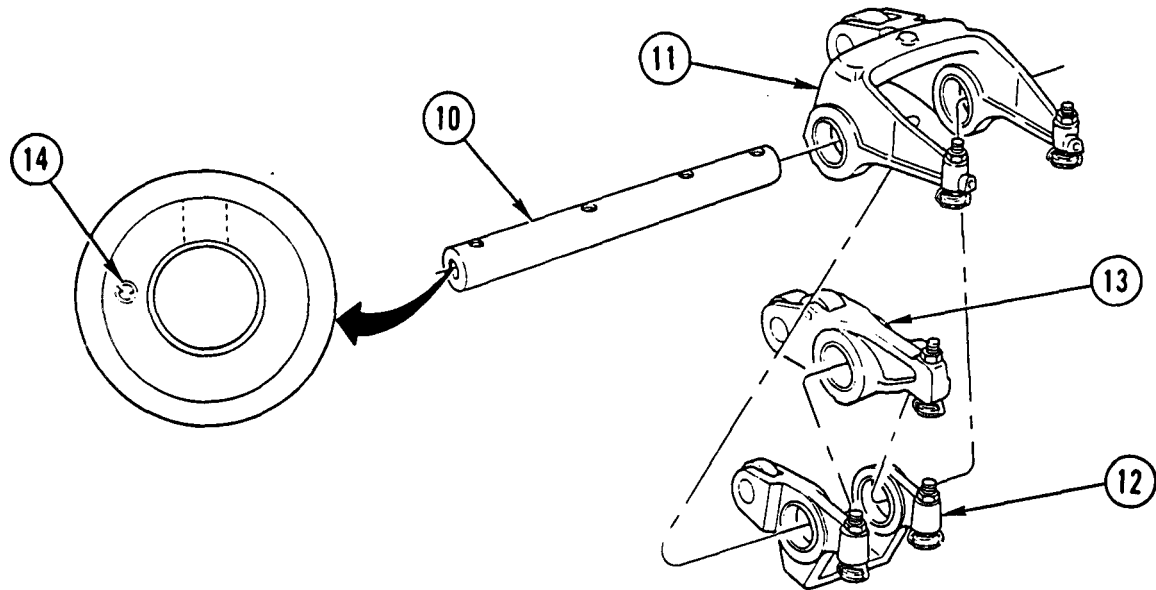

NOTE

- If rocker arms are reused, install in previously determined order.
- Logo on rocker arm shaft must be on outboard (front and rear) when seated.

5. LUBRICATE ROCKER ARM BUSHING WITH CLEAN ENGINE LUBRICATING OIL. INSTALL THREE ROCKER ARM ASSEMBLY SETS (EXHAUST (11), INTAKE (12), AND INJECTOR (13)) ON ROCKER ARM SHAFT (10 WITH LOGO (14) STAMPED ON END OF SHAFT (10)).

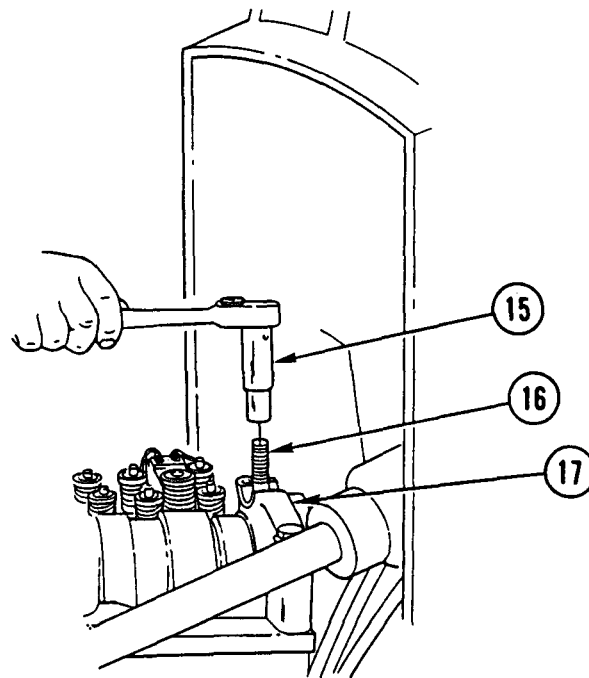

6. USING ROCKER STUD SOCKET (15), CHECK TIGHTNESS OF ROCKER ARM SHAFT STUDS (16) IN CAM CAPS (17) NO. 1 AND NO. 7. TIGHTEN STUDS TO 75-86 LB-FT (101-116 N.m).

ROCKER ARM ASSEMBLIES REPLACEMENT (CONT)

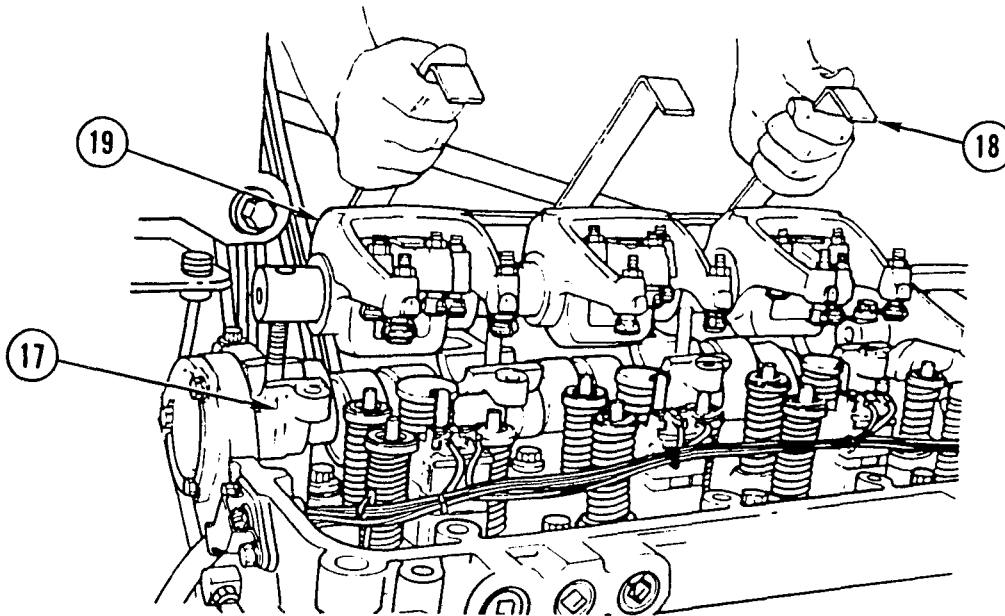

NOTE

Position lifter fingers under cross arch of exhaust rocker arm assembly (above center section of injector rocker assembly). Lifter fingers fit between intake and injector rockers.

7. USING ROCKER ARM LIFTER (18) ON ROCKER ARM ASSEMBLIES (19) FROM CAM ROLLER SIDE, PLACE ROCKER ARM SHAFT AND ROCKER ARM ASSEMBLIES (19) IN POSITION ON CAM CAPS (17).

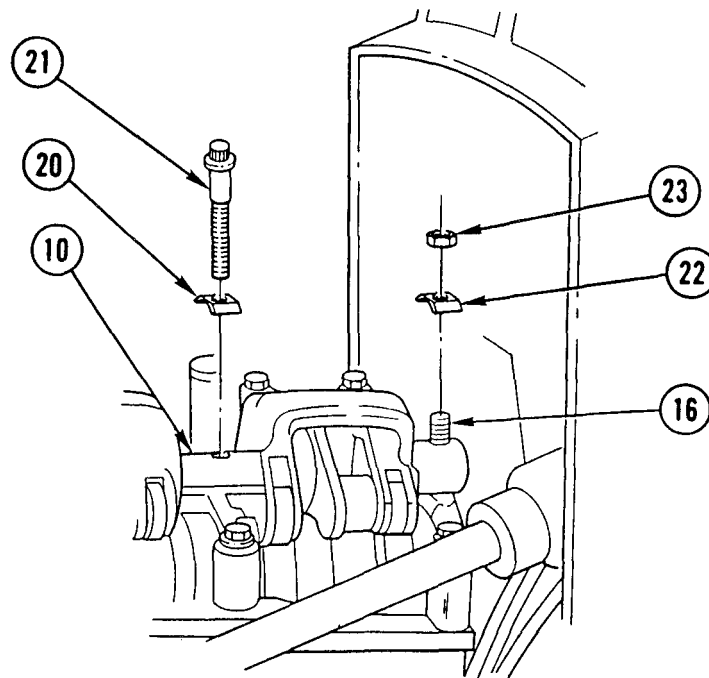

8. INSTALL SIX SADDLE SPACERS (20) ON SIX RETAINING BOLTS (21).
9. INSTALL SIX RETAINING BOLTS (21) THRU ROCKER ARM SHAF (10) AND CAM CAP SADDLES.
10. INSTALL TWO SADDLE SPACERS (22) AND TWO NUTS (23) ON ROCKER ARM SHAFTSTUDS (16).

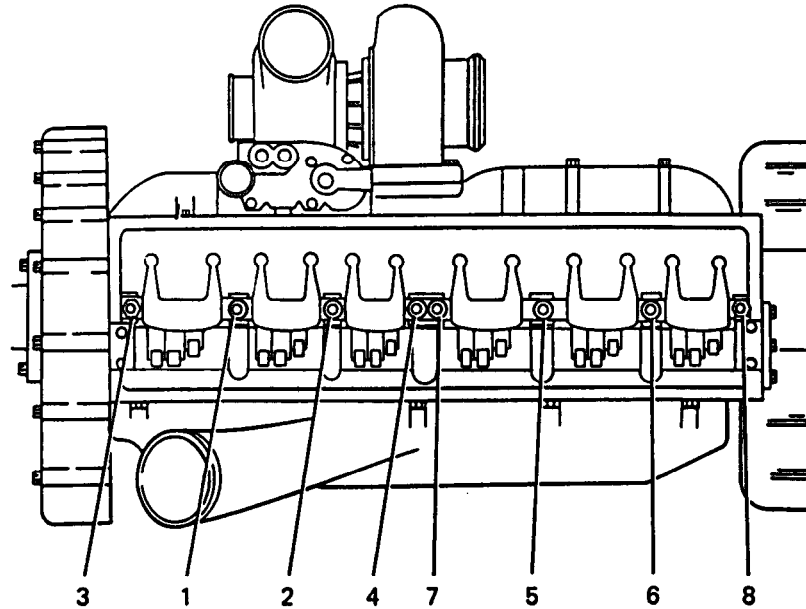

11. TIGHTEN SIX RETAINING BOLTS AND TWO NUTS TO 75-86 LB-FT (101-116 N.m) IN SEQUENCE SHOWN.

ROCKER ARM ASSEMBLIES REPLACEMENT (CONT)

ADJUSTMENT

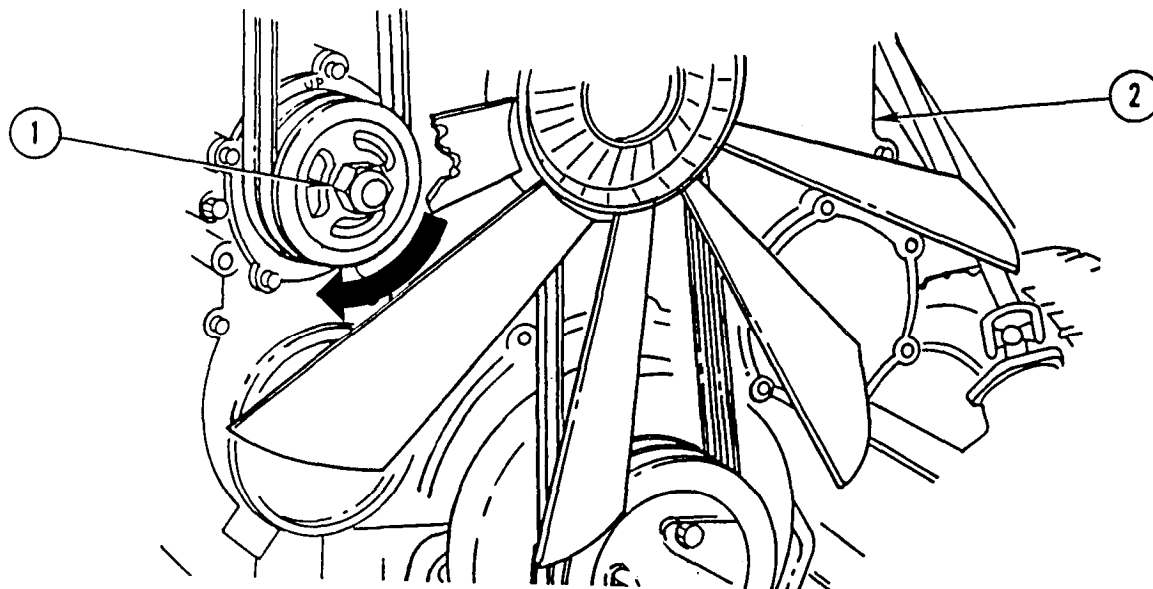

CAUTION

Turn accessory drive in clockwise direction only when barring engine over to prevent damage to equipment.

NOTE

- Using following method, it will only be necessary to bar engine over two complete revolutions. Three cylinders are adjusted, either valves or injectors, on each revolution.
 - To adjust valves and set fuel injector height, bar engine over until one fuel injector begins its downward stroke. Adjust all valves (two intake, two exhaust) at this cylinder position and set fuel injector height on companion cylinder shown on timing circle chart.
 - Never set valves and injector of same cylinder at same time.
 - Bar engine over in clockwise direction until fuel injector for next cylinder shown in timing circle chart begins its downward stroke. Adjust valves for this cylinder and set fuel injector height for companion cylinder shown on timing circle chart.
 - Continue around timing circle chart until six sets of valves and fuel injectors have been adjusted.
1. USING ACCESSORY DRIVE (1, BAR ENGINE (2) OVER. STOP ENGINE ROTATION WHEN ANY FUEL INJECTOR FOLLOWER JUST BEGINS ITS DOWNWARD STROKE. NOTE NUMBER OF THIS CYLINDER.

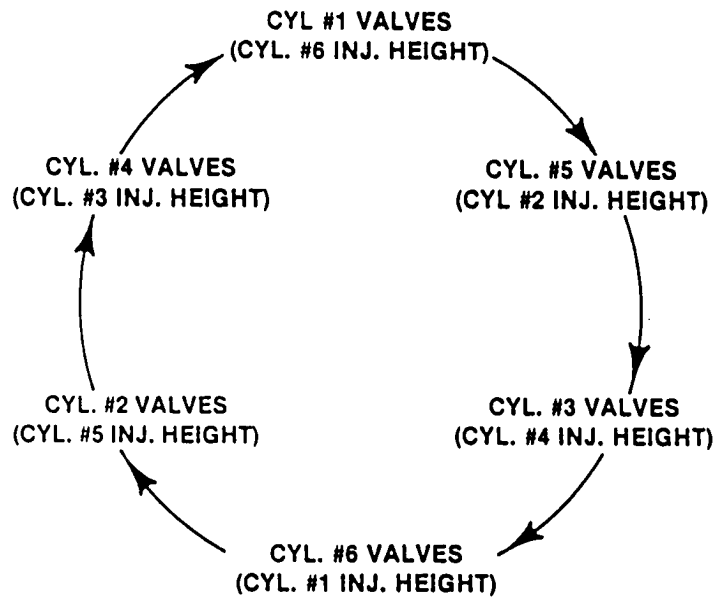

TIMING CIRCLE CHART

NOTE

Timing circle can be started with any cylinder. Make sure timing circle is completed to set all valves and injectors.

2. REFER TO TIMING CIRCLE CHART AND LOCATE CYLINDER.

ROCKER ARM ASSEMBLIES REPLACEMENT (CONT)

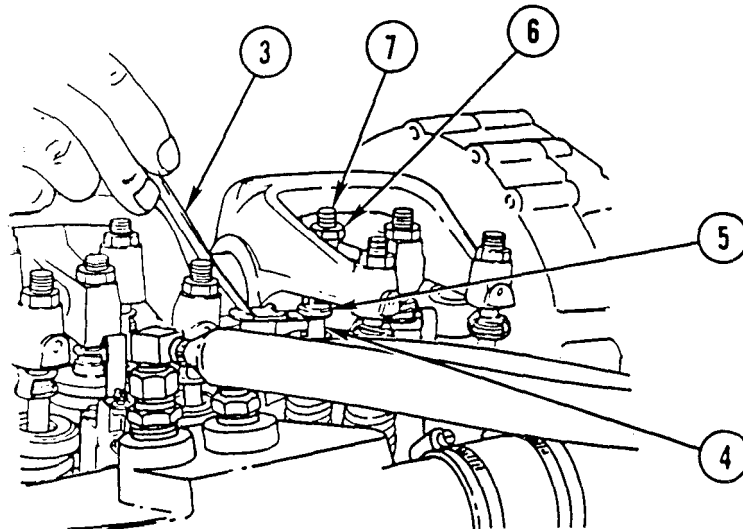

3. INSERT 0.008 IN. (0.203 mm) FEELER GAGE (3) BETWEEN TIP OF INTAKE VALVE STEM (4) AND INTAKE VALVE BUTON (5) AT END OF ROCKER ARM.
4. LOOSEN JAM NUT (6) AND TURN ADJUSTING SCREW (7) UNTIL FEELER GAGE (3) PRODUCES EVEN OR SMOOTH PULL BETWEEN INTAKE VALVE STEM (4) AND INTAKE VALVE BUTTON (5).
5. TIGHTEN JAM NUT (6) TO 30-35 LB-FT (41-47 N.m) AND REMOVE FEELER GAGE (3).
6. INSERT FEELER GAGE (3) AGAIN TO MAKE SURE ADJUSTMENT DID NOT CHANGE WHEN NUT (6) WAS TIGHTENED. READJUST AS NECESSARY.
7. EXHAUST VALVES ARE ADJUSTED SAME WAY AS INTAKE VALVES EXCEPT FOR USE OF 0.020 IN. (0.508 mm) FEELER GAGE.
8. COMPLETE ADJUSTMENT OF ALL VALVES (TWO INTAKE, TWO EXHAUST) FOR CYLINDER BEFORE PROCEEDING.
9. REFER TO TIMING CIRCLE CHART AND NOTE CYLINDER NUMBER FOR NEXT VALVE AND INJECTOR ADJUSTMENT.

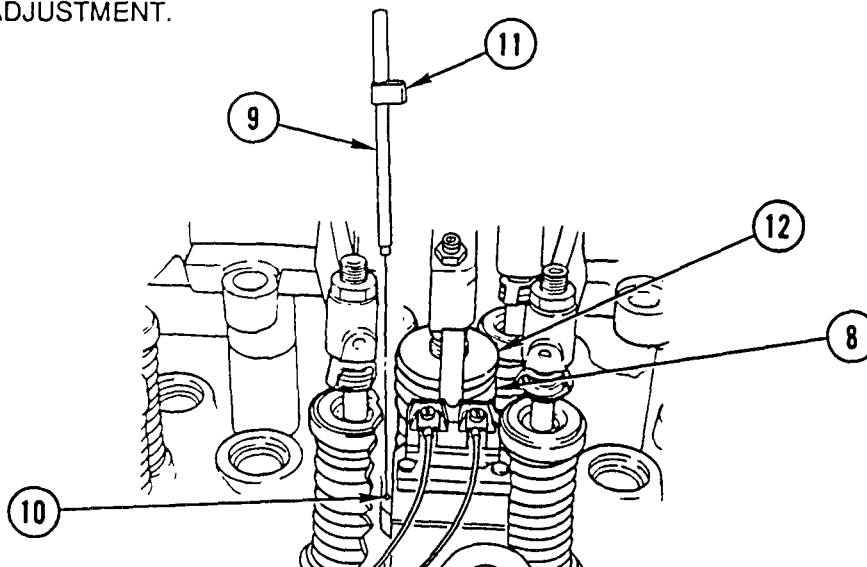

NOTE

Make sure injector timing height gauge is seated on machined surface with tip in pilot hole. Foreign material in pilot hole or on machined surface may prevent accurate setting of injector height.

10. ADJUST HEIGHT OF FUEL INJECTOR (6) FOR CYLINDER INDICATED ON TIMING CIRCLE CHART BY PLACING SMALL END OF INJECTOR TIMING HEIGHT GAUGE (9) IN HOLE IN FUEL INJECTOR BODY (10) WITH FLAG (11) OF GAUGE TOWARD FUEL INJECTOR PLUNGER (12), AS SHOWN.

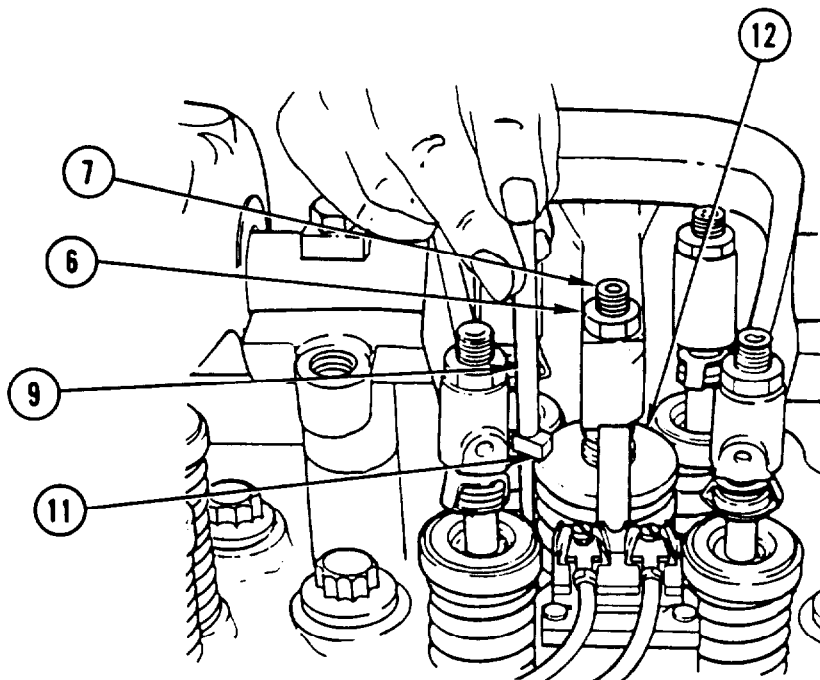

11. LOOSEN JAM NUT (6) AND TURN ADJUSTING SCREW (7) UNTIL FLAG (11) OF INJECTOR TIMING HEIGHT GAUGE (9) JUST CLEARS TOP OF FUEL INJECTOR PLUNGER (12). AN ACCURATE FEEL WILL BE DEVELOPED. ADJUST ALL INJECTORS TO SAME FEEL.
12. TIGHTEN JAM NUT (6) TO 30-35 LB-FT (41-47 N.m). CHECK ADJUSTMENT WITH INJECTOR TIMING HEIGHT GAUGE (9) AND, IF NECESSARY, READJUST.
13. REMOVE INJECTOR TIMING HEIGHT GAUGE (9).
14. REFER TO TIMING CIRCLE CHART AND FOLLOW ARROW TO NEXT CYLINDER IN ADJUSTMENT SEQUENCE.

ROCKER ARM ASSEMBLIES REPLACEMENT (CONT)

COMPONENT	CHECKING DIMENSIONS	SETTING DIMENSION
FUEL INJECTOR	77.95 - 78.45 mm (3.068" - 3.088")	78.2 mm (3.078") (DDEC II) 78.8 mm (3.102") (DDEC III)
INTAKE VALVE	0.152 - 0.254 mm (0.006" - 0.010")	0.203 mm (0.008")
EXHAUST VALVE	0.457 - 0.558 mm (0.018" - 0.022")	0.508 mm (0.020")

15. BAR ENGINE OVER IN DIRECTION OF NORMAL ROTATION UNTIL INJECTOR FOLLOWER OF NEXT CYLINDER IN ADJUSTMENT SEQUENCE BEGINS ITS DOWNWARD MOTION.
16. REPEAT VALVE ADJUSTMENT AND FUEL INJECTOR HEIGHT ADJUSTMENT PROCEDURES UNTIL ALL VALVES AND FUEL INJECTORS HAVE BEEN ADJUSTED.

NOTE

Tune-up settings may vary even when using correct setting procedures.

17. CHART INDICATES ACCEPTABLE CHECKING TOLERANCES DETERMINED TO ENSURE ENGINE PERFORMANCE AND ALLOW FOR NORMAL VARIABILITY.

NOTE

Follow-on Maintenance:

Install engine retarder (page 3-129).

OIL PUMP REPLACEMENT AND REPAIR

This task covers: a. Removal b. Disassembly c. Cleaning d. Inspection e. Repair f. Assembly
g. Installation

Took and Special Equipment:

Shop Equipment, SC 4910-95-CL-A31
Tool Kit, SC 5180-90-CL-N05

Materials/Parts:

Bushing	P/N B-21951
Ring, Seal	P/N 23505891
Ring, Seal	P/N 23505892
Pin, Dowel	P/N 23505885
Pin, Dowel	P/N 8929011
Gasket	P/N 23505992
Gasket	P/N 5117269
Gasket	P/N 8929347
Nuts, Lock	
Oil, Lubricating	Appendix B, Item 37
Lubriplate 105	Appendix B, Item 35

References:

TM 9-237

Equipment Condition:

Reference	Condition Description
Page 3-220	Oil Pan Removed

General Safety Instructions:

WARNING

Sealing compounds can burn easily, can give off harmful vapors, and are harmful to skin and clothing. To avoid injury or death, keep away from open fire and use in well-ventilated area. If sealing compound gets on skin or clothing, wash immediately with soap and water.

OIL PUMP REPLACEMENT AND REPAIR (CONT)

REMOVAL

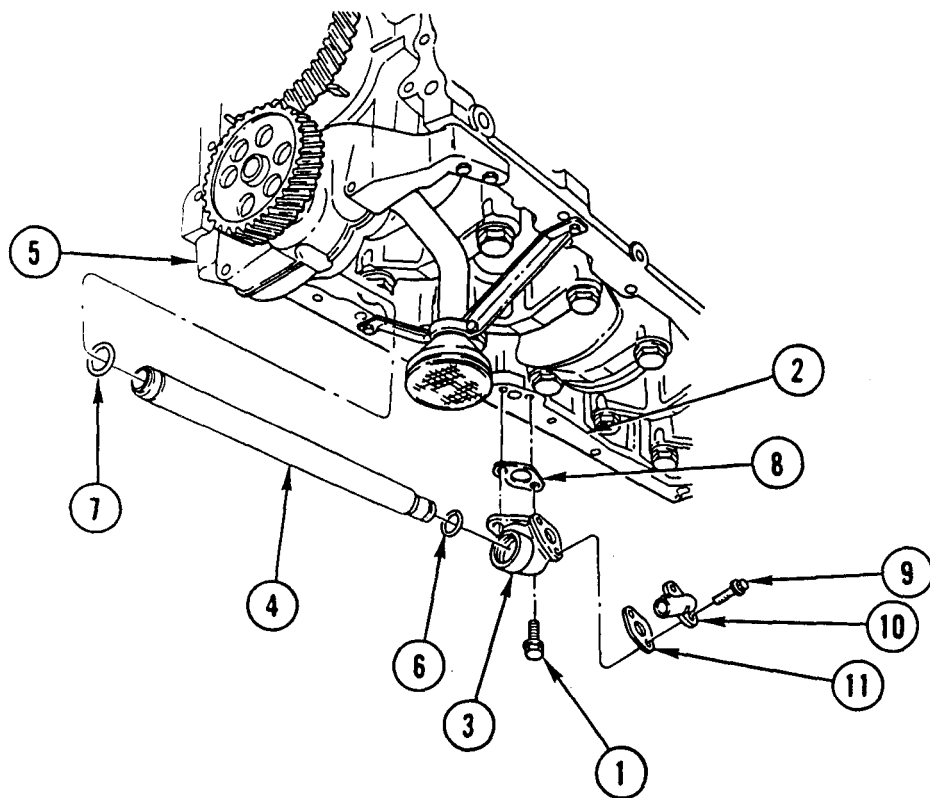

1. REMOVE TWO BOLTS (1) FROM CYLINDER BLOCK (2).
2. REMOVE OIL OUTLET TUBE ELBOW (3) AND OIL OUTLET TUBE (4) FROM OIL PUMP ASSEMBLY (5).
3. REMOVE OIL OUTLET TUBE (4) FROM OIL OUTLET TUBE ELBOW (3).
4. REMOVE AND DISCARD TWO SEAL RINGS (6 AND 7).
5. REMOVE AND DISCARD GASKET (8).
6. REMOVE TWO BOLTS (9) FROM OIL OUTLET TUBE ELBOW (3).
7. REMOVE OIL PRESSURE RELIEF VALVE (10) AND GASKET (11). DISCARD GASKET.

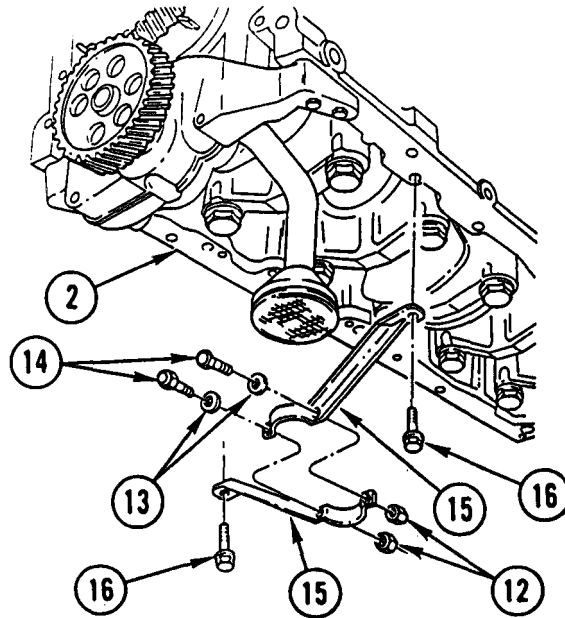

8. REMOVE TWO LOCK NUTS (12), TWO WASHERS (13), AND TWO BOLTS (14) FROM INLET OIL TUBE BRACKET HALVES (15). DISCARD LOCK NUTS.
9. REMOVE TWO BOLTS (16) AND INLET OIL TUBE BRACKET HALVES (15) FROM CYLINDER BLOCK (2).

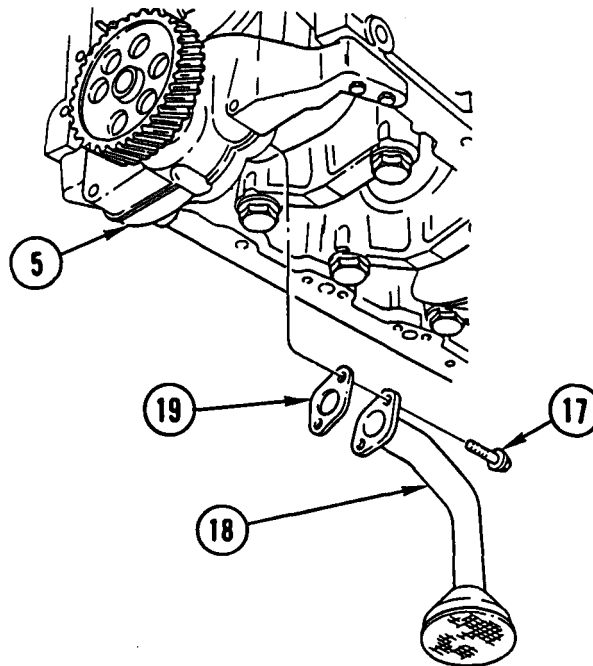

CAUTION

Oil pump must be adequately supported to prevent pump from dropping when retaining bolts are removed.

10. REMOVE TWO BOLTS (17), OIL INLET TUBE (18), AND GASKET (19) FROM OIL PUMP ASSEMBLY (5). DISCARD GASKET.

OIL PUMP REPLACEMENT AND REPAIR (CONT)

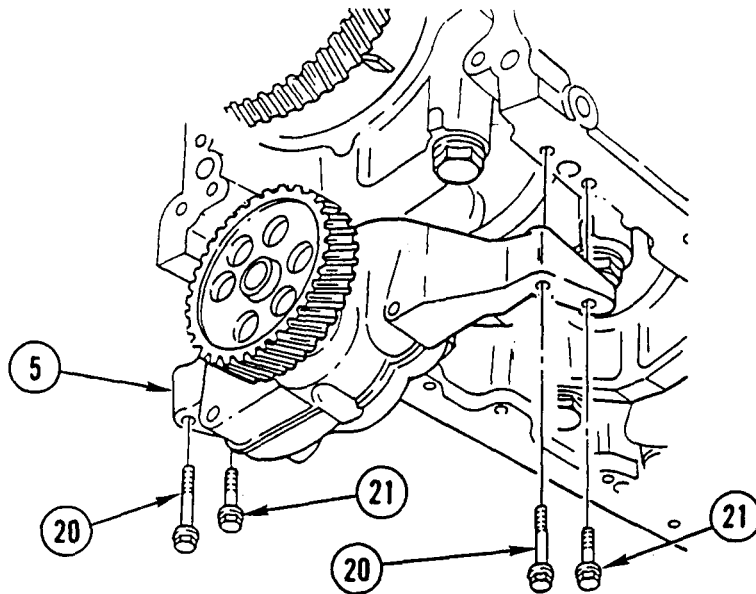

11. REMOVE TWO LONG BOLTS (20), Two SHORT BOLTS (21), AND OIL PUMP ASSEMBLY (5).

DISASSEMBLY

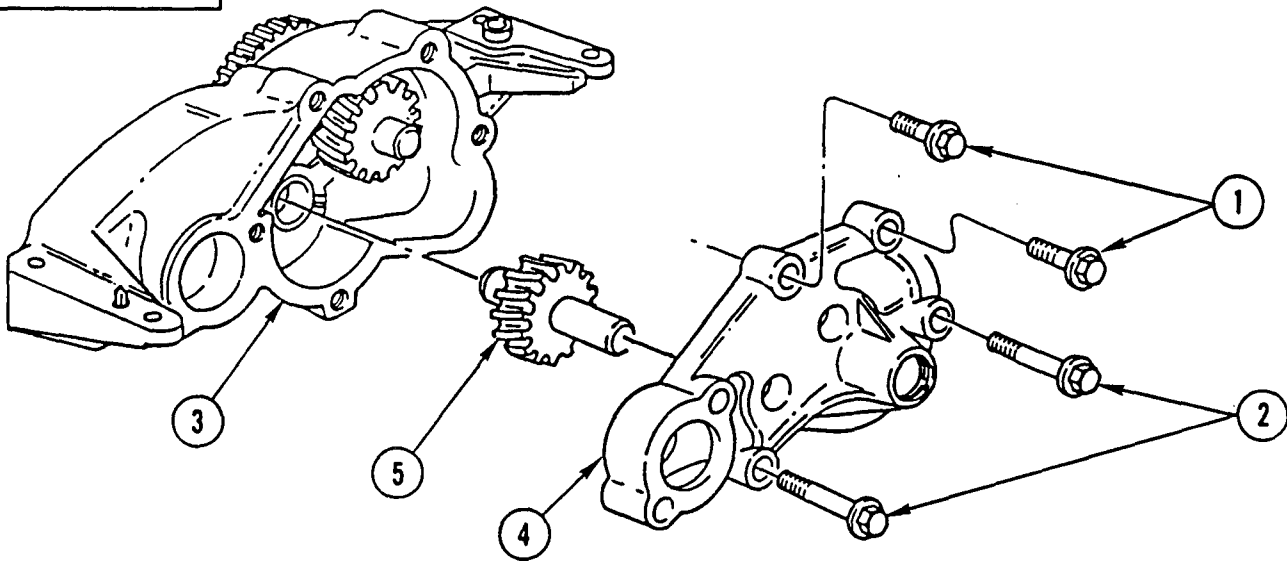

1. REMOVE TWO SHORT BOLTS (1) AND TWO LONG BOLTS (2) FROM OIL PUMP BODY (3).

CAUTION

Be careful when removing oil pump cover to prevent damage to equipment, Oil pump driven gear and shaft assembly is retained in oil pump assembly only by cover.

2. REMOVE OIL PUMP COVER (4) AND OIL PUMP DRIVEN GEAR AND SHAFT ASSEMBLY (5) FROM OIL PUMP BODY (3).

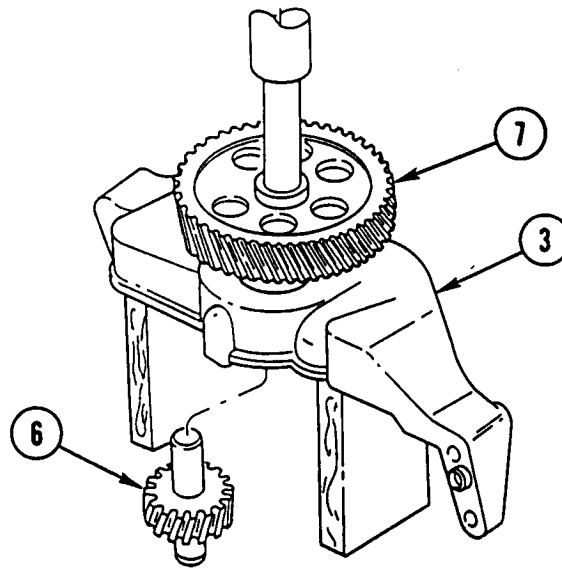
**CAUTION**

Do not allow press support to interfere with oil pump drive gear and shaft assembly being pressed out. To do so will result in damage to shaft assembly.

3. PLACE OIL PUMP BODY (3), PUMP COVER SIDE DOWN, ON PRESS SUPPORT. PRESS OIL PUMP DRIVE GEAR AND SHAFT ASSEMBLY (6) FROM OIL PUMP DRIVE GEAR (7).
4. REMOVE OIL PUMP DRIVE GEAR (7) FROM OIL PUMP BODY (3).

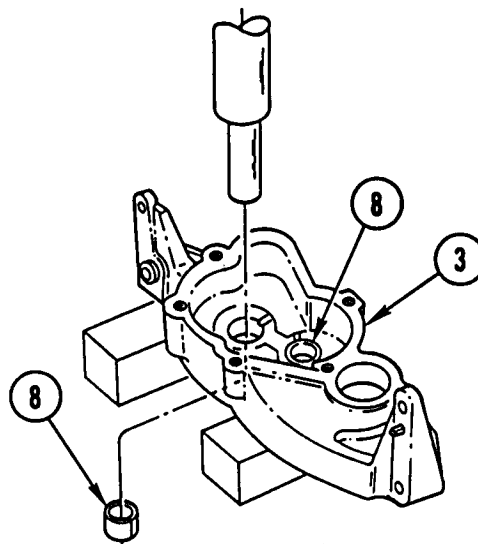
**NOTE**

When one or more bushings require replacing, replace all bushings in pump body and pump cover.

5. IF BUSHINGS ARE DAMAGED OR WORN, PLACE OIL PUMP BODY (3), PUMP COVER SIDE UP, ON PRESS SUPPORT. PRESS BUSHINGS (8) FROM PUMP BODY (3).

OIL PUMP REPLACEMENT AND REPAIR (CONT)

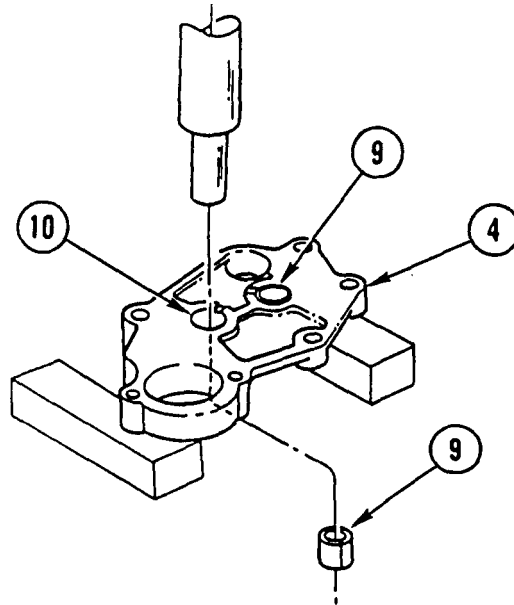

6. PLACE OIL PUMP COVER (4), PUMP BODY SIDE UP, ON PRESS SUPPORT. PRESS OUT BUSHINGS (9) FROM HOUSING BORES (10).

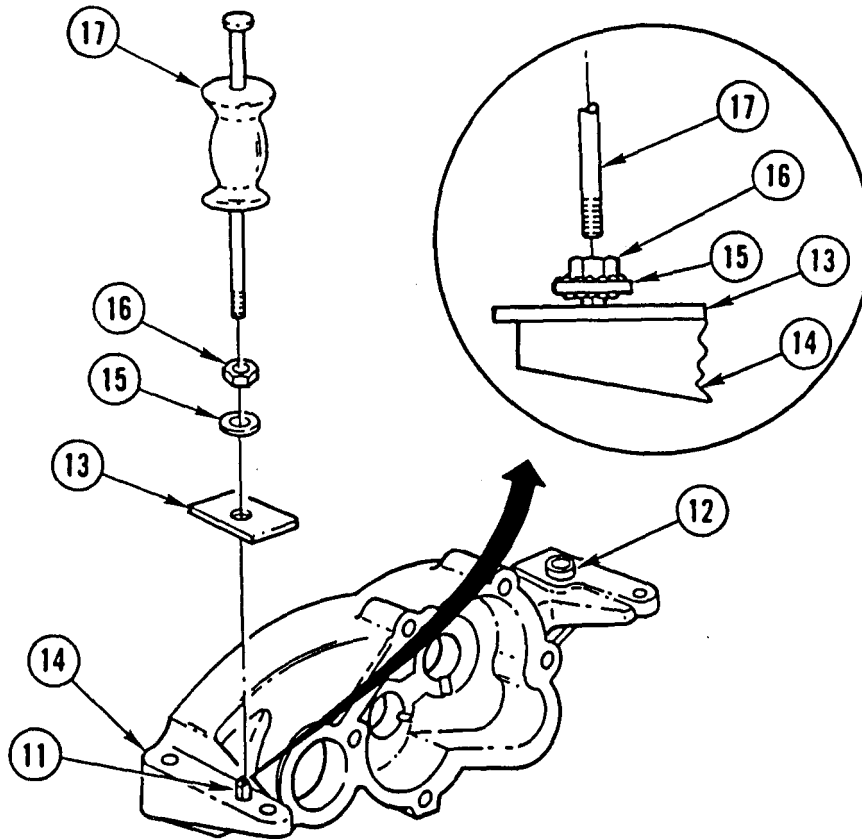

CAUTION

Extreme care should be taken to protect surfaces of mounting legs from electric arc welding slag. Use fabricated protective plate for this purpose. Failure to do so could result in damage to surfaces of mounting legs.

NOTE

Two steel locating dowels (one solid diamond shaped dowel and one tubular shaped dowel) installed on pump body mounting legs are pressed in bores to specified depths. Both dowels are extremely durable and should never need to be replaced.

7. IF REMOVAL OF EITHER DOWEL (11) OR (12) IS REQUIRED, PLACE PROTECTIVE PLATE (13) ON SMOOTH SURFACE OF MOUNTING LEG (14) OVER DOWEL TO BE REMOVED. TACK-WELD WASHER (15) AND NUT (16) TO DOWEL.

NOTE

Secure pump body in soft-jawed vise with machined (smooth) surfaces of mounting legs facing up.

8. ATTACH SLIDE HAMMER (17) TO WELDED NUT ON DOWEL (11 OR 12) BEING REMOVED, AND APPLY SHORT UPWARD SHOCKING ACTIONS UNTIL DOWEL IS FREED FROM BORE. DISCARD DOWEL WITH WELDED NUT AND WASHER.

CLEANING

Use general cleaning methods to clean all parts (page 2-30).

INSPECTION

1. INSPECT ALL PARTS FOR WEAR OR DAMAGE.
2. DISCARD PUMP BODY OR PUMP COVER IF CRACKED, OR IF EVIDENCE OF SPUN BUSHINGS IN BUSHING BORES IS VISIBLE.
3. INSPECT BUSHINGS IN PUMP BODY AND COVER. SHAFT-TO-PUMP BODY BUSHING CLEARANCE WITH NEW PARTS IS 0.0016-0.0024 IN. (0.04-0.06 mm). MAXIMUM ALLOWABLE SHAFT-TO-PUMP COVER BUSHING CLEARANCE WITH USED PARTS IS 0.0035 IN. (0.089 mm).

REPAIR

Use general repair methods to repair damaged parts (page 2-33).

OIL PUMP REPLACEMENT AND REPAIR (CONT)

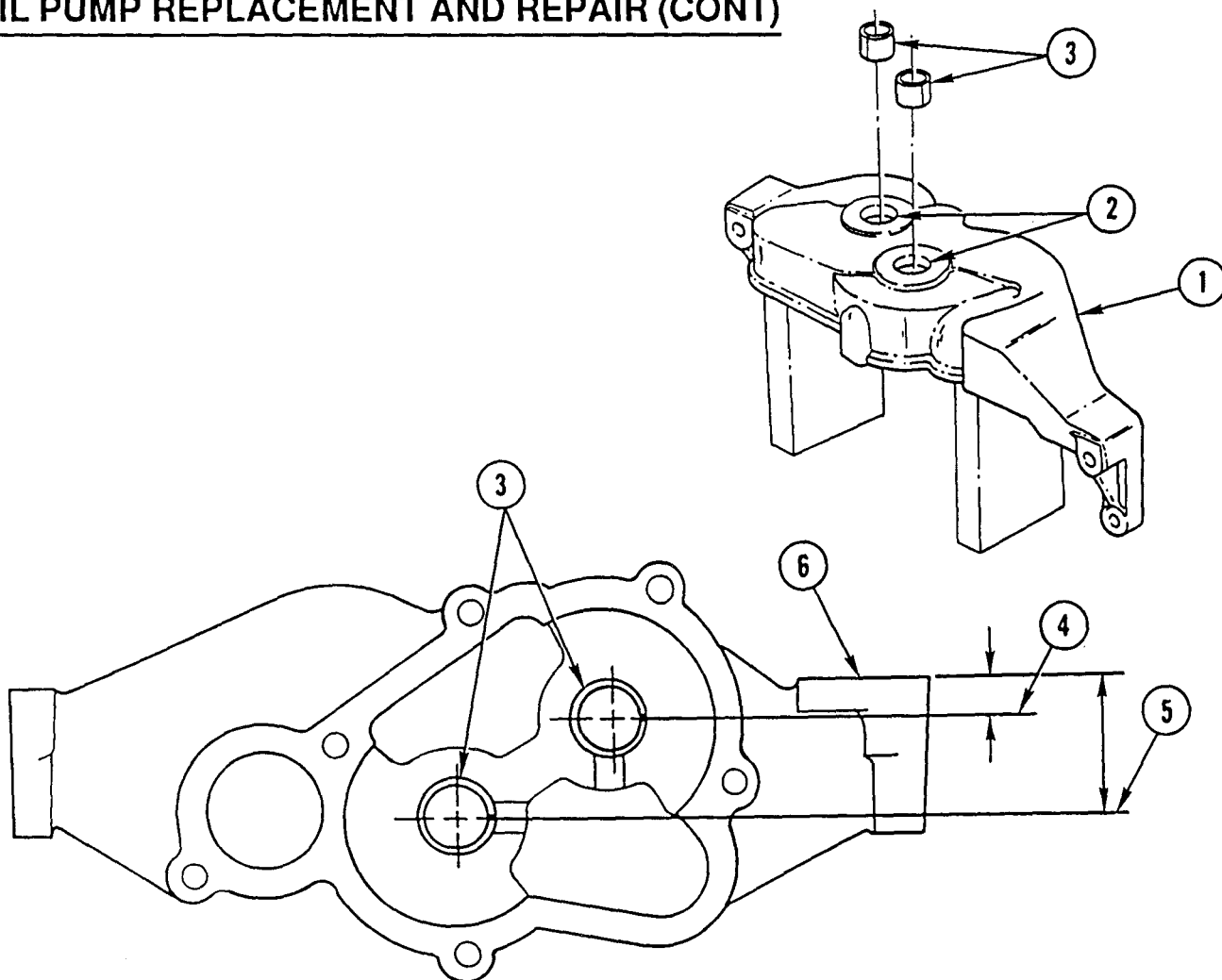

ASSEMBLY

1. PLACE OIL PUMP BODY (1), COVER SIDE DOWN, ON PRESS SUPPORT.
2. APPLY THIN FILM OF LUBRIPLATE 105 TO BUSHING BORES (2).
3. POSITION BUSHINGS (3) LOOSELY OVER PUMP BODY BUSHING BORES (2).
4. ROTATE BUSHINGS (3) SO SPLIT LINES (4 AND 5) ARE PARALLEL WITH MACHINED SURFACE (6) OF PUMP BODY.
5. WHEN PROPERLY ALINED, SPLIT LINE (4) SHOULD MEASURE 0.461 IN. (11.705 mm) TO SURFACE (6). SPLIT LINE (5) SHOULD MEASURE 1.726 IN. (43.82 mm) TO SURFACE (6).

NOTE

Bushings must be installed flush to specified depth below finished surface of pump body.

6. PRESS BUSHINGS (3) IN PUMP BODY BUSHING BORES (2) NOT MORE THAN 0.031 IN. (0.8 mm) BELOW FINISHED SURFACE OF OIL PUMP BODY (1).

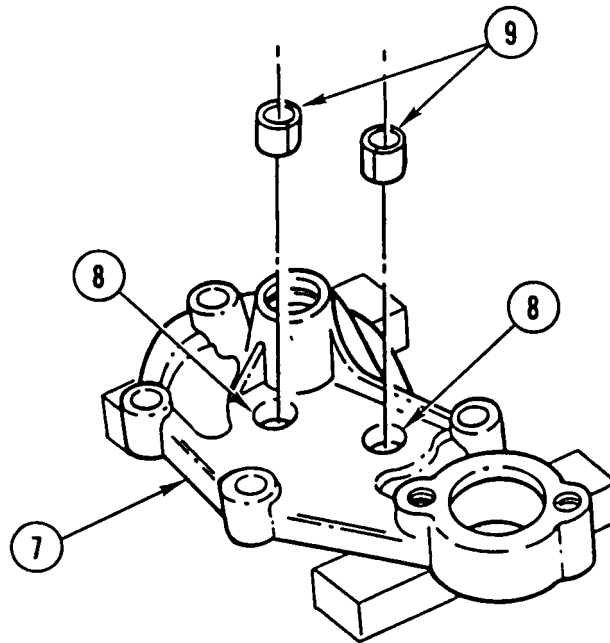

7. PLACE OIL PUMP COVER (7), PUMP BODY SIDE DOWN, ON PRESS SUPPORT. APPLY THIN FILM OF LUBRIPLATE 105 TO BUSHING BORES (8).
8. POSITION BUSHINGS (9) LOOSELY OVER PUMP COVER BUSHING BORES (8).
9. ROTATE BUSHINGS (9) SO SPLIT LINES (10) ARE ALINED IN PUMP COVER BUSHING BORES AS SHOWN.

NOTE

Bushings must be installed to specified depth below finished surface of pump cover.

10. PRESS BUSHINGS (9) IN PUMP COVER BUSHING BORES (8) 0.011-0.031 IN. (0.3-0.8 mm) BELOW FINISHED SURFACE OF OIL PUMP COVER (7).

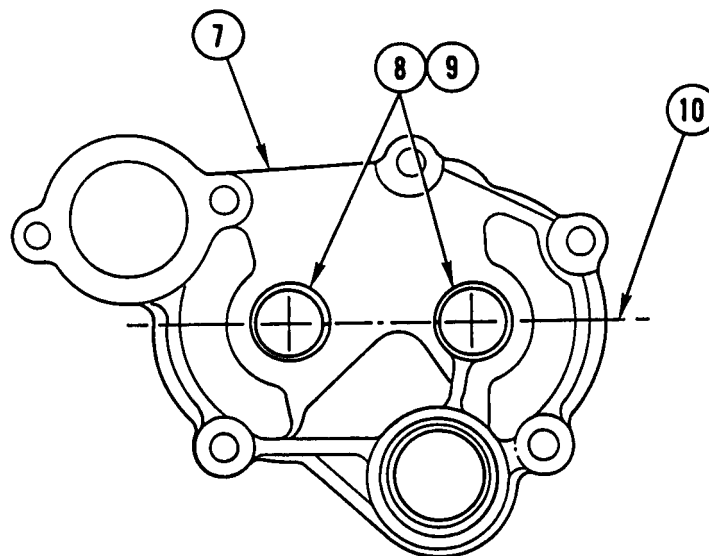

OIL PUMP REPLACEMENT AND REPAIR (CONT)

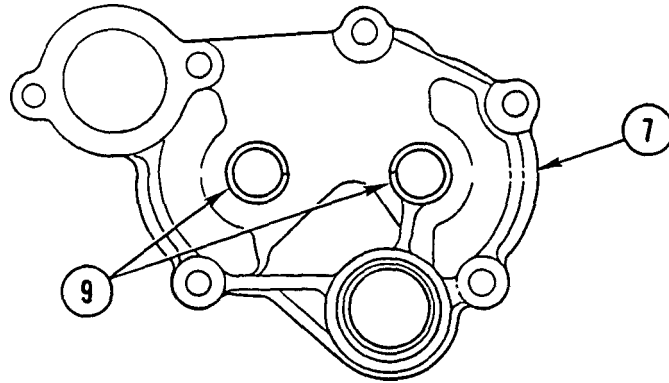

PUMP COVER

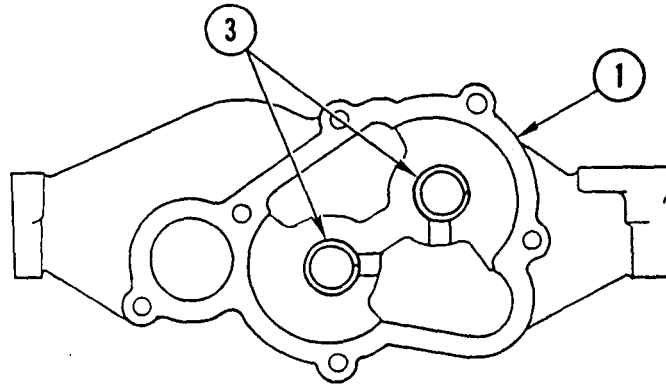

PUMP BODY

NOTE

Pump body and pump cover bushings are finished to size after installation in their respective bores. Use single point tooling to avoid smearing oil retention surfaces.

- 11. BORE OUT INSIDE DIAMETER OF BUSHINGS (3 AND 9) IN OIL PUMP BODY (1) AND OIL PUMP COVER (7) TO 0.879-0.880 IN. (22.32-22.35 mm).

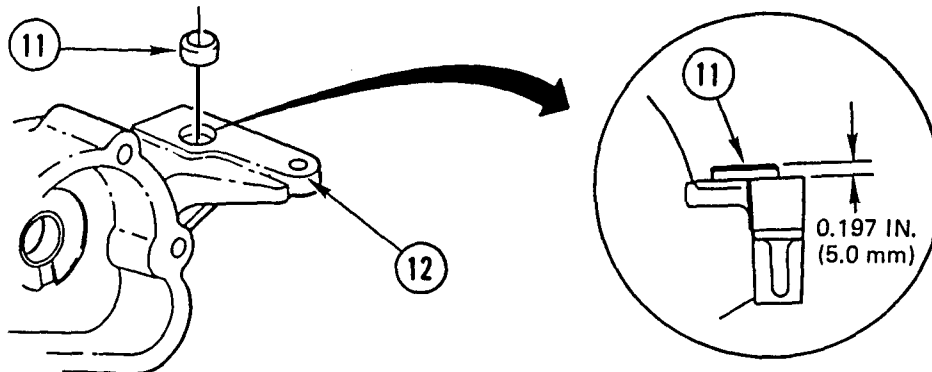

12. INSTALL ROUND DOWEL (11) IN BORE OF PUMP BODY MOUNTING SURFACE (12). TOP OF ROUND DOWEL (11) SHOULD BE 0.197 IN. (5.0 mm) FROM MOUNTING SURFACE (12) WHEN PROPERLY SEATED IN BORE.

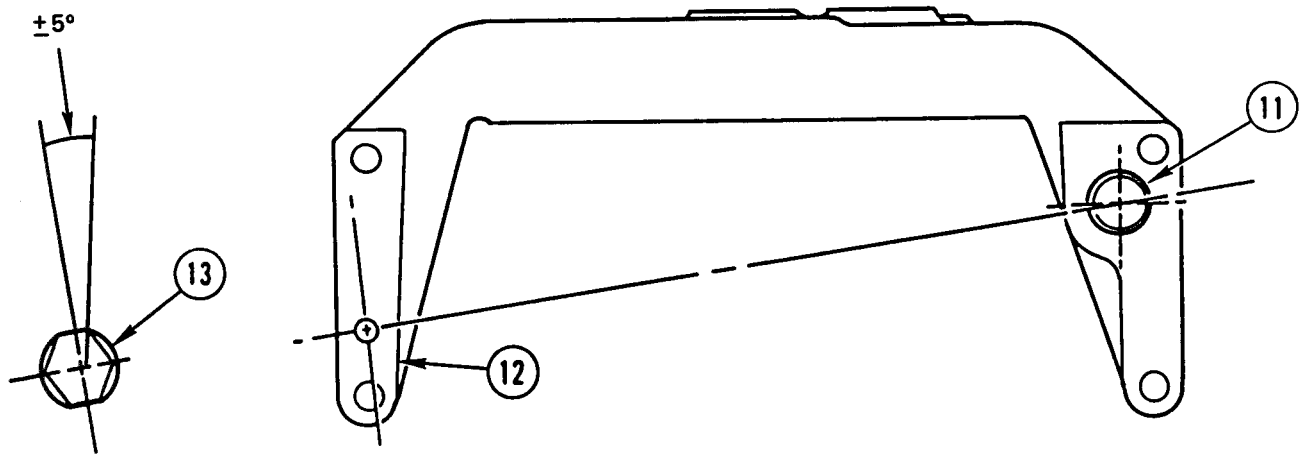

NOTE

Diamond dowel must be oriented in relation to round dowel before installing in pump body mounting surface.

13. LOOSELY PLACE DIAMOND DOWEL (13) IN BORE OF PUMP BODY MOUNTING SURFACE (12) SO ANGULAR ORIENTATION IS PERPENDICULAR TO CENTER LINE THROUGH ROUND DOWEL (11) WITHIN 5 DEGREES.

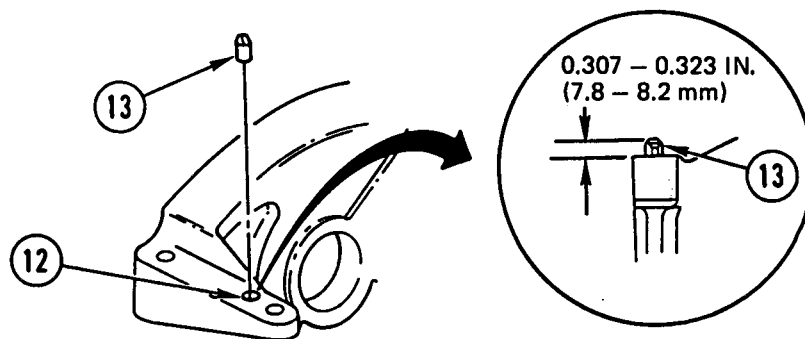

14. INSTALL DIAMOND DOWEL (13) IN BORE OF PUMP BODY MOUNTING SURFACE (12). TOP OF DIAMOND DOWEL (13) SHOULD BE 0.307-0,323 IN. (7.8-8.2 mm) ABOVE SURFACE (12) WHEN PROPERLY SEATED IN BORE.

OIL PUMP REPLACEMENT AND REPAIR (CONT)

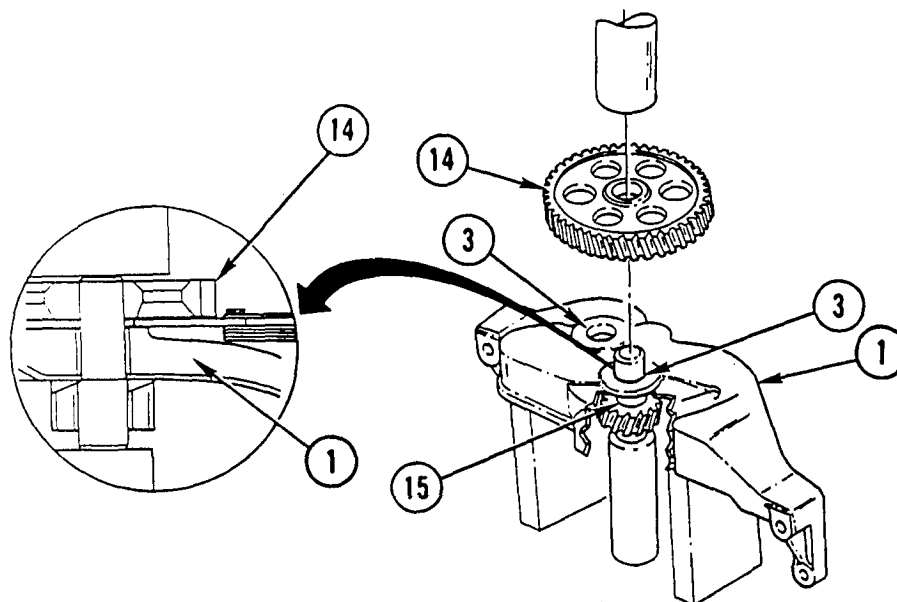

15. PLACE OIL PUMP BODY (1), WITH COVER SIDE DOWN, ON PRESS SUPPORT. LUBRICATE TWO BUSHINGS (3) WITH CLEAN ENGINE LUBRICATING OIL.
16. APPLY THIN FILM OF LUBRIPLATE 105 TO BORE OF OIL PUMP DRIVE GEAR (14).
17. INSTALL LONGER END OF INTERNAL OIL PUMP DRIVE GEAR (14) AND SHAFT ASSEMBLY (15) IN RIGHT SIDE BUSHING AS VIEWED FROM TOP REAR.

CAUTION

- Minimum press force of 1,515 lb. (7.0 kN) must be obtained to press oil pump drive gear onto oil pump drive gear and shaft assembly to prevent damage to equipment.
- Balance holes in drive gear rim must face pump body to avoid possibility of installing drive gear backwards.

18. PLACE END OF INTERNAL OIL PUMP DRIVE GEAR (14) AND SHAFT ASSEMBLY (15) ON PRESS SUPPORT, PRESS OIL PUMP DRIVE GEAR (14) ON GEAR AND SHAFT ASSEMBLY (15), USING FEELER GAGE, ENSURE THAT CLEARANCE OF 0.033-0.044 IN. (0.85-1.15 mm) IS OBTAINED BETWEEN OIL PUMP DRIVE GEAR (14) AND OIL PUMP BODY (1).

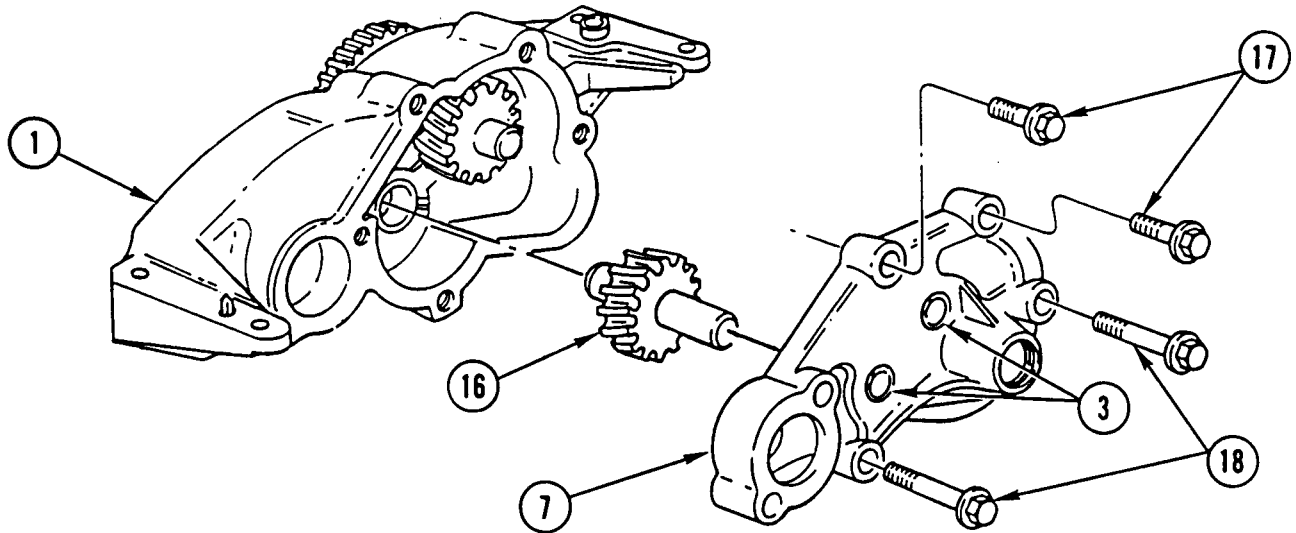

19. INSTALL SHORTER END OF OIL PUMP DRIVEN GEAR AND SHAFT ASSEMBLY (16) IN LEFT SIDE BUSHING IN OIL PUMP BODY (1) AS VIEWED FROM TOP REAR.
20. LUBRICATE BUSHINGS (3) IN OIL PUMP COVER (7) WITH LIGHT ENGINE LUBRICATING OIL.
21. INSTALL OIL PUMP COVER (7) ON OIL PUMP BODY (1).
22. INSTALL TWO SHORTER BOLTS (17) IN UPPER TWO BOLTS HOLES AND TWO LONGER BOLTS (18) IN LOWER TWO BOLT HOLES IN OIL PUMP COVER (7). TIGHTEN BOLTS TO 22-28 LB-FT (30-38 N.m) IN CRISSCROSS PATTERN.

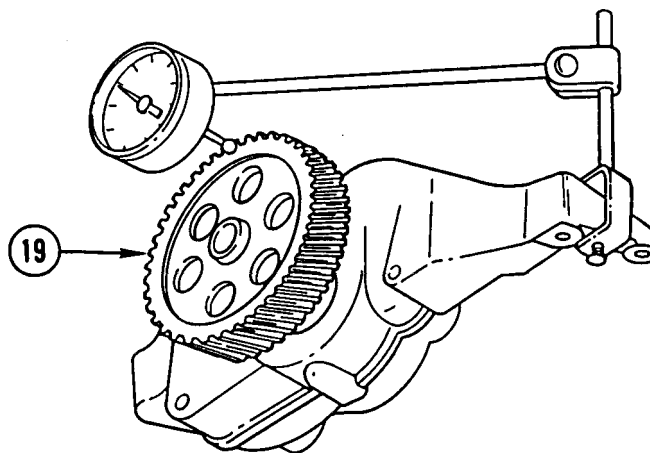

23. MOUNT DIAL INDICATOR ON MACHINED SURFACE OF RIGHT SIDE OIL PUMP BODY MOUNTING LEG OR OTHER SUITABLE CLAMPING SURFACE.
24. MEASURE GEAR FACE RUNOUT JUST INBOARD OF OIL PUMP DRIVE GEAR TEETH (19) WHILE ROTATING GEAR BY HAND. GEAR FACE RUNOUT MUST NOT EXCEED 0.003 IN. (0.007 mm). IF GEAR FACE RUNOUT EXCEEDS 0.003 IN. (0.007 mm), REPLACE GEAR.

OIL PUMP REPLACEMENT AND REPAIR (CONT)

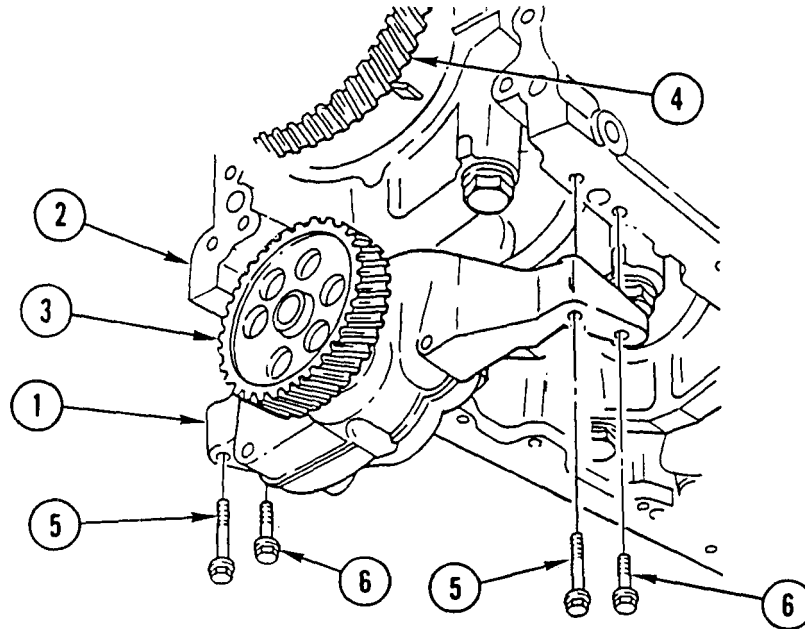

1. POSITION OIL PUMP ASSEMBLY (1) ON CYLINDER BLOCK (2) WITH OIL PUMP DRIVE GEAR (3) ENGAGED WITH CRANKSHAFT GEAR (4). MAKE SURE RING DOWEL AND DIAMOND DOWEL ARE FULLY SEATED IN CYLINDER BLOCK (2).
2. INSTALL TWO LONGER BOLTS (5) IN FRONT BOLT HOLES AND TWO SHORTER BOLTS (6) IN REAR BOLT HOLES IN OIL PUMP ASSEMBLY (1). TIGHTEN BOLTS TO 43-54 LB-FT (58-73 N.m) IN CRISSCROSS PATTERN.

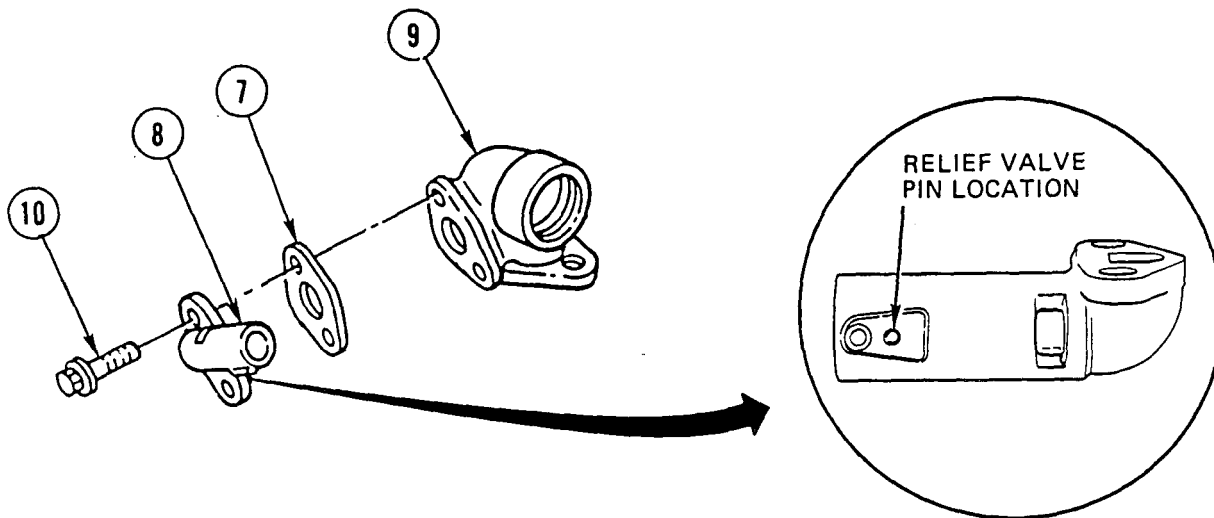

CAUTION

Do not interchange oil pressure regulator valve and oil pressure relief valve to prevent damage to equipment, Oil pressure regulator valve port opening is larger than oil pressure relief valve port opening. Oil pressure regulator valve is also identified by pin located farthest from outlet port.

NOTE

Make sure all old gasket material has been removed from mating surfaces of oil pressure relief valve and elbow.

3. INSTALL NEW GASKET (7) AND OIL PRESSURE RELIEF VALVE (8) ON OIL OUTLET TUBE ELBOW (9). INSTALL TWO BOLTS (10) AND TIGHTEN TO 22-24LB-FT (30-38 N.m).

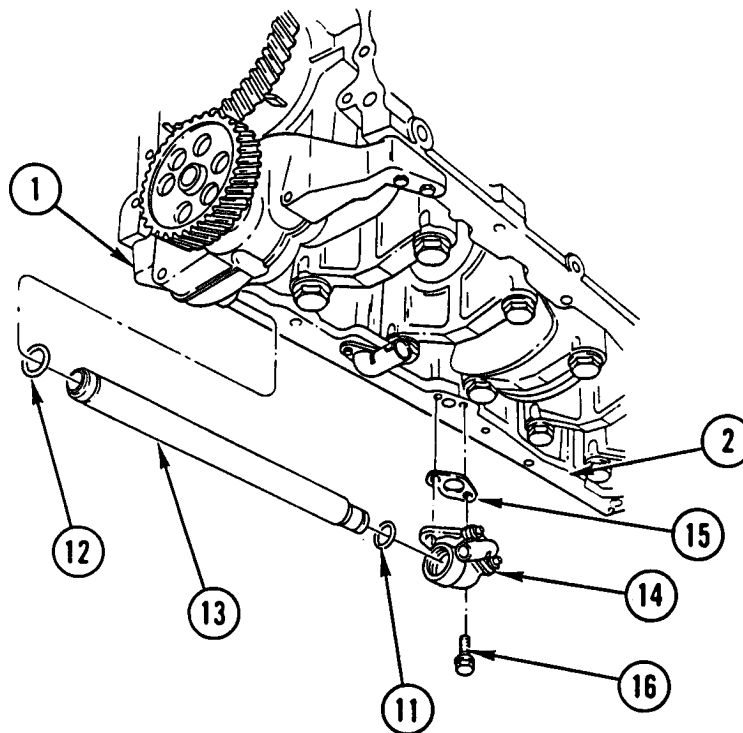

4. COAT TWO NEW SEAL RINGS (11 AND 12) WITH LIGHT ENGINE LUBRICATING OIL. INSTALL SMALLER SEAL RING ON ELBOW END OF OIL OUTLET TUBE (13) AND LARGER SEAL RING ON PUMP END OF OIL OUTLET TUBE (13).
5. INSTALL LARGER DIAMETER END OF OIL OUTLET TUBE (13) IN OUTLET NECK OF OIL PUMP ASSEMBLY (1) UNTIL OIL OUTLET TUBE (13) BOTTOMS IN BORE.
6. INSTALL SMALLER DIAMETER END OF OIL OUTLET TUBE (13) IN OIL OUTLET TUBE ELBOW (14) UNTIL OIL OUTLET TUBE (13) BOTTOMS IN BORE.

NOTE

Make sure all old gasket material has been removed from mating surfaces of oil outlet tube elbow and cylinder block.

7. INSTALL NEW GASKET (15) AND OIL OUTLET TUBE ELBOW ASSEMBLY (14) ON CYLINDER BLOCK (2). INSTALL TWO BOLTS (16) AND TIGHTEN TO 22-24 LB-FT (30-38 N.m).

OIL PUMP REPLACEMENT AND REPAIR (CONT)

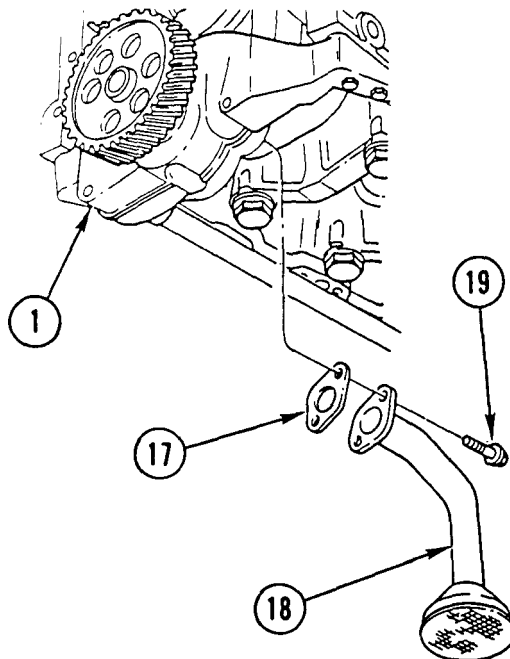

8. INSTALL NEW GASKET (17) AND OIL INLET TUBE (18) ON OIL PUMP ASSEMBLY (1). INSTALL TWO BOLTS (19) AND TIGHTEN TO 22-24 LB-FT (30-38 N.m).

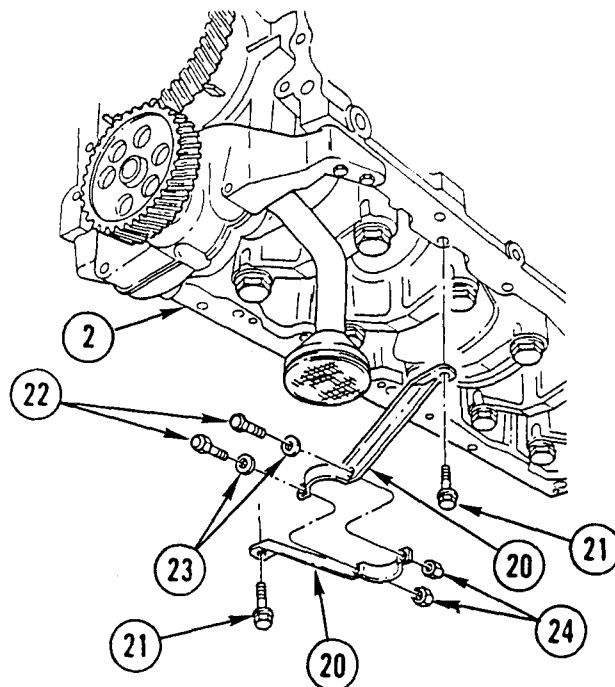

9. INSTALL TWO OIL INLET TUBE BRACKET HALVES (20) AND TWO BOLTS (21) ON CYLINDER BLOCK (2), TIGHTEN BOLTS TO 43-54 LB-FT (58-73 N.m).
10. INSTALL TWO BOLTS (22), TWO WASHERS (23), AND TWO NEW LOCK NUTS (24) ON OIL INLET TUBE BRACKET HALVES (20). TIGHTEN BOLTS TO 43-54 LB-FT (58-73 N.m).

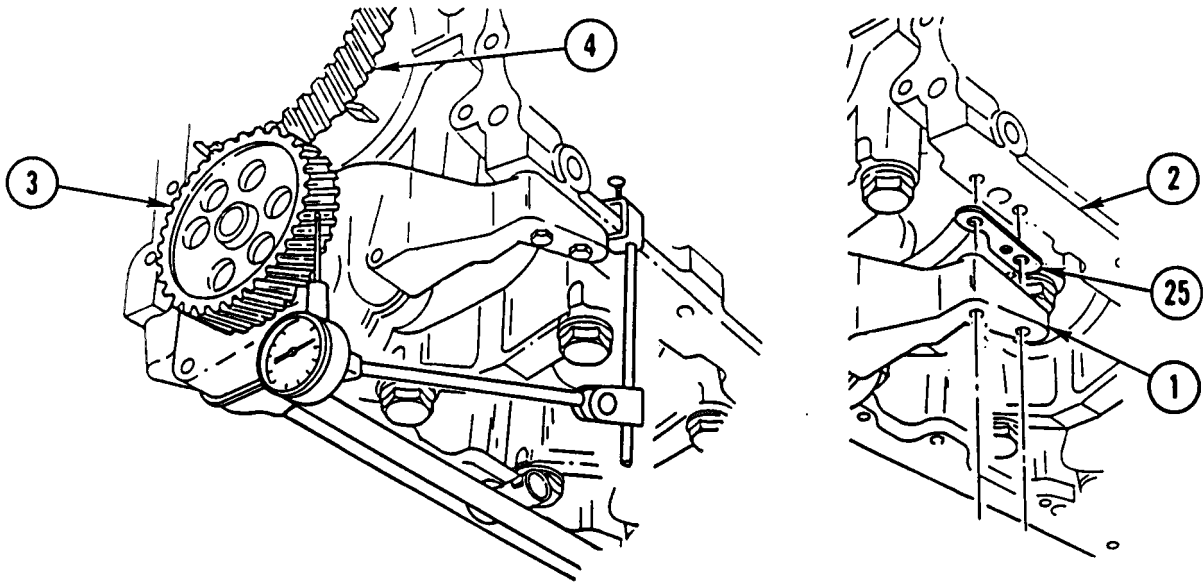
**NOTE**

- Gear lash measurements between crankshaft gear and oil pump drive gear must be taken with engine in running position.
- Remove or install shims as necessary to obtain proper lash.

11. WITH DIAL INDICATOR TIP RESTING ON TOOTH OF OIL PUMP DRIVE GEAR (3), MEASURE GEAR LASH BETWEEN OIL PUMP DRIVE GEAR AND CRANKSHAFT DRIVE GEAR (4). GEAR LASH SHOULD BE 0.002-0.009 IN. (0.051-0.229 mm).
12. IF GEAR TOOTH CLEARANCE IS NOT WITHIN SPECIFICATIONS, REPEAT REMOVAL STEPS 1 THRU 10.
13. INSTALL REQUIRED AMOUNT OF SHIMS (25) BETWEEN OIL PUMP ASSEMBLY (1) AND CYLINDER BLOCK (2).
14. REPEAT INSTALLATION STEPS 1 THRU 10.
15. VERIFY GEAR LASH. REPEAT STEP 11.

NOTE

Follow-on Maintenance:

Install oil pan (page 3-220).

OIL RELIEF VALVE AND OIL REGULATOR VALVE REPLACEMENT

This task covers: a. Removal b. Cleaning c. Inspection d. Installation

INITIAL SETUP

Tools and Special Equipment:

Shop Equipment, SC 4910-95-CL-A31
 Tool Kit, SC 5180-90-CL-N05

Equipment Condition:

Reference
 Page 3-220

Condition Description
 Oil Pan Removed

Materials/Parts:

Ring, Seal	P/N 23505891
Ring, Seal	P/N 23505892
Gasket	P/N 5117269
Gasket	P/N 8929347
Oil, Lubricating	Appendix B, Item 37

REMOVAL

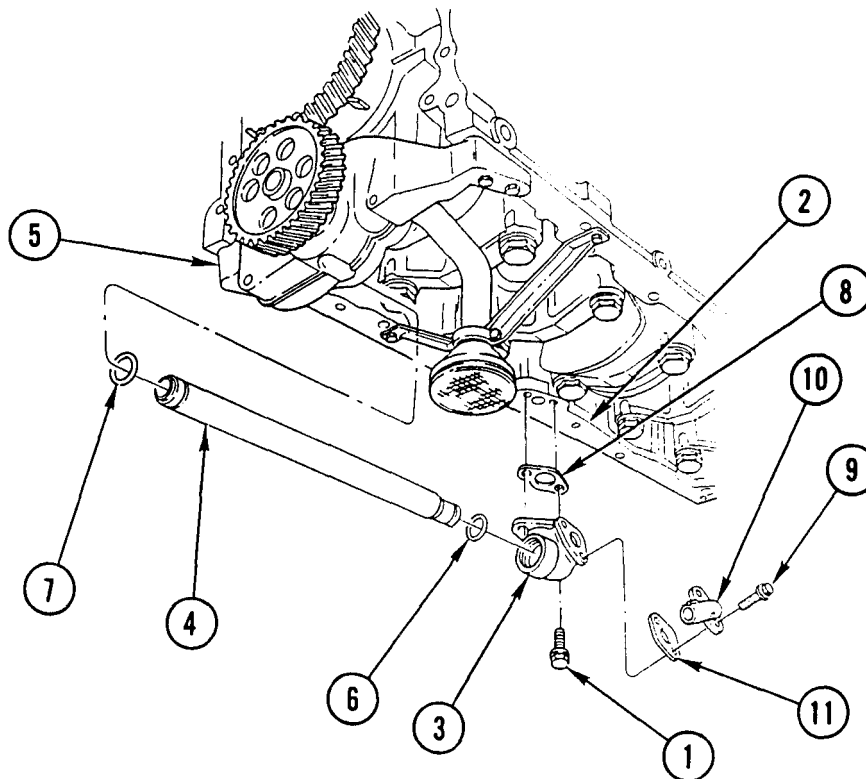

1. REMOVE TWO BOLTS (1) FROM CYLINDER BLOCK (2).
2. REMOVE OIL OUTLET TUBE ELBOW (3) FROM OIL OUTLET TUBE (4) AND REMOVE OUTLET TUBE (4) FROM OIL PUMP ASSEMBLY (5).
3. REMOVE AND DISCARD TWO SEAL RINGS (6 AND 7).
4. REMOVE AND DISCARD GASKET (8).
5. REMOVE TWO BOLTS (9) FROM OIL OUTLET TUBE ELBOW (3).
6. REMOVE OIL PRESSURE RELIEF VALVE (10) AND GASKET (11). DISCARD GASKET.

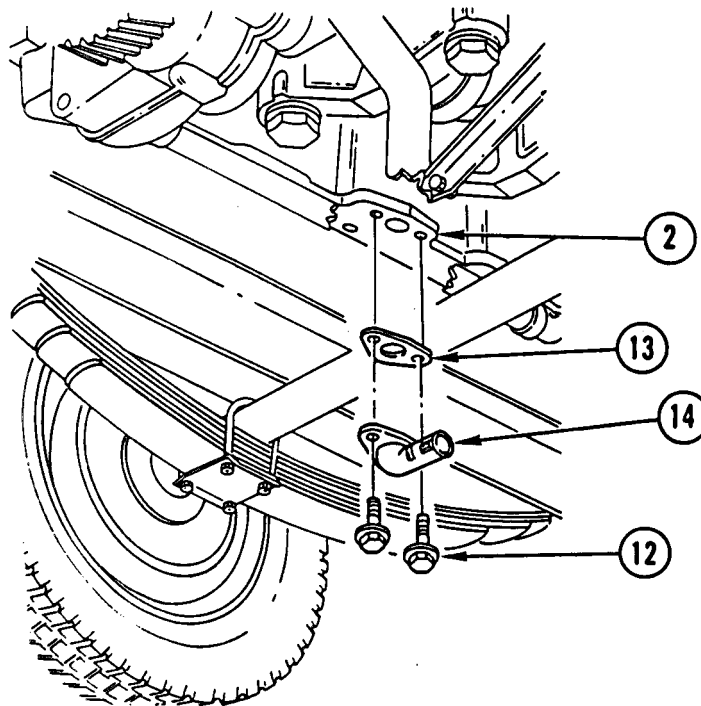

7. REMOVE TWO BOLTS (12) FROM CYLINDER BLOCK (2).
8. TAP OIL PRESSURE REGULATOR VALVE BODY LIGHTLY TO LOOSEN IT FROM GASKET (13) AND REMOVE OIL PRESSURE REGULATOR VALVE (14). DISCARD GASKET.

CLEANING

1. CLEAN ALL OLD GASKET MATERIAL FROM OIL PRESSURE REGULATOR VALVE BODY AND CYLINDER BLOCK MATING SURFACES.
2. USE GENERAL CLEANING METHODS TO CLEAN ALL PARTS (PAGE 2-30).

INSPECTION

Inspect all parts for wear or damage. If parts are pitted or scored, replace.

OIL RELIEF VALVE AND OIL REGULATOR VALVE REPLACEMENT (CONT)

INSTALLATION

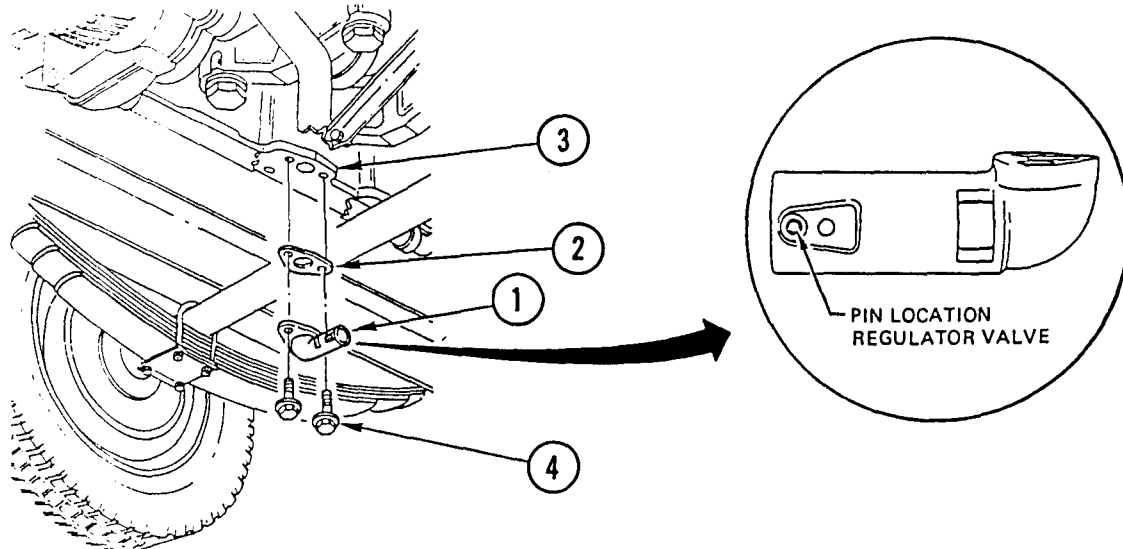

CAUTION

Do not interchange oil pressure regulator valve and oil pressure relief valve to prevent damage to equipment. Oil pressure regulator valve port opening is larger than oil pressure relief valve port opening. Oil pressure regulator valve is also identified by pin located farthest from outlet port.

1. INSTALL OIL PRESSURE REGULATOR VALVE (1) AND NEW GASKET (2) ON CYLINDER BLOCK (3).
2. INSTALL TWO BOLTS (4) AND TIGHTEN TO 22-28 LB-FT (30-38 N.m).

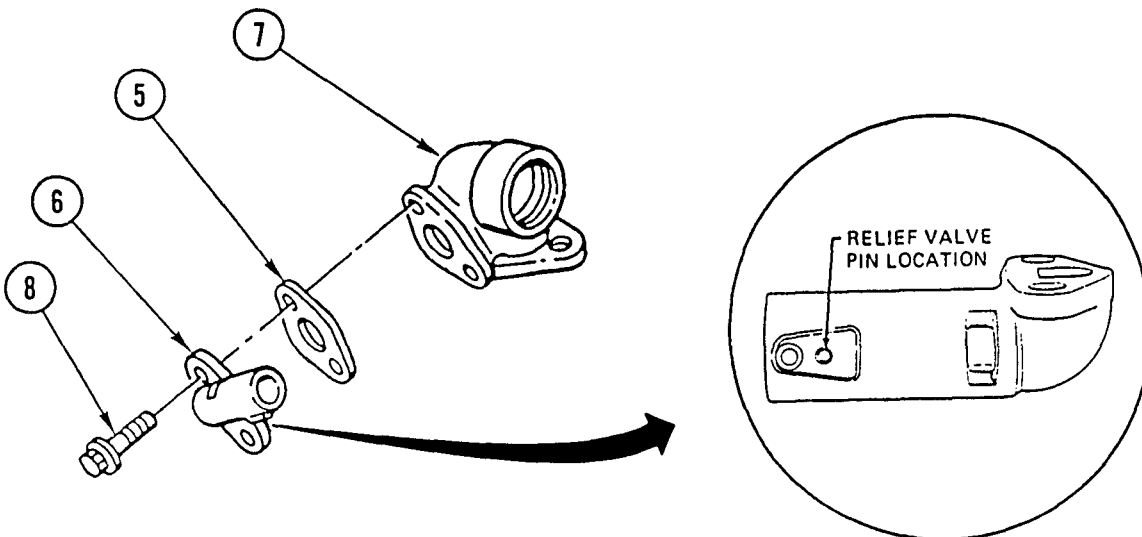

NOTE

Make sure all old gasket material has been removed from mating surfaces of oil pressure relief valve and elbow.

3. INSTALL NEW GASKET (5) AND OIL PRESSURE RELIEF VALVE (6) ON OIL OUTLET TUBE ELBOW(7).
4. INSTALL TWO BOLTS (8) AND TIGHTEN TO 22-24LB-FT (30-38 N.m).

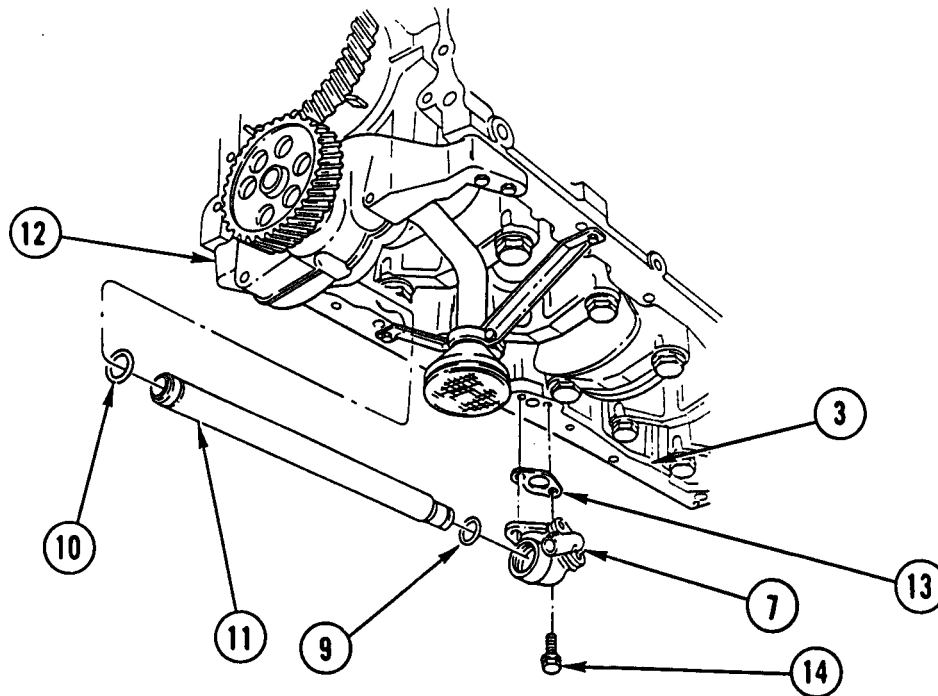

5. COAT TWO NEW SEAL RINGS (9 AND 10) WITH CLEAN ENGINE LUBRICATING OIL.
6. INSTALL SMALLER SEAL RING (9) ON ELBOW END OF OIL OUTLET TUBE (11) AND LARGER SEAL RING (10) ON PUMP END OF OIL OUTLET TUBE(11).
7. INSTALL LARGER DIAMETER END OF OIL OUTLET TUBE (11) IN OUTLET NECK OF OIL PUMP ASSEMBLY UNTIL OIL OUTLET TUBE(11) BOTTOMS IN BORE.
8. INSTALL SMALLER DIAMETER END OF OIL OUTLET TUBE(11) IN OIL OUTLET TUBE ELBOW (7) UNTIL OIL OUTLET TUBE(11) BOTTOMS IN BORE.
9. INSTALL NEW GASKET (13) AND OIL OUTLET TUBE ELBOW ASSEMBLY (7) ON CYLINDER BLOCK (3).
10. INSTALL TWO BOLTS (14) AND TIGHTEN TO 22-24 LB-H (30-38 N.m).

NOTE

Follow-on Maintenance:

Install oil pan (page 3-220).

OIL PAN REPLACEMENT

This task covers: a. Removal b. Cleaning c. Inspection d. Repair e. Installation

INITIAL SETUP

Tools and Special Equipment:

Shop Equipment, SC 4910-95-CL-A31
 Tool Kit, SC 5180-90-CL-N05

Materials/Parts:

Gasket	P/N 8929102
Seal Kit (Engines prior to S/N 06R0394932)	P/N 23521330
Oil Lubricating	Appendix B, Item 37
Compound, Pipe Sealing	Appendix B, Item 15
Sealant, RTV	Appendix B, Item 52

References:

LO 9-2320-363-12

Equipment Condition:

Reference	Condition Description
LO 9-2320-363-12	Engine Oil Drained

General Safety Instructions:

WARNING

To prevent injury, compressed air will not exceed 30 psi (207 kPa). Use only with effective ship guarding and personal protective equipment, goggles, shield, and gloves.

Personnel Required: (2)

REMOVAL

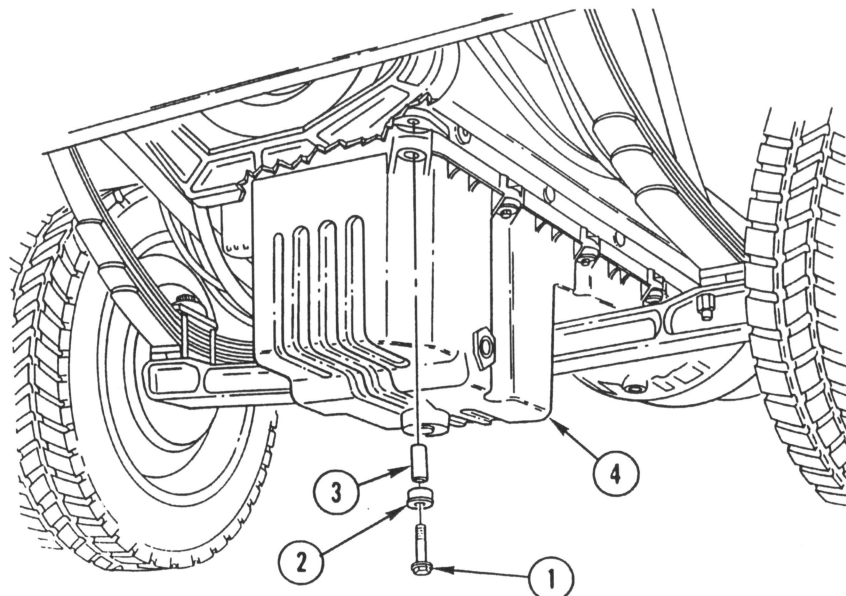

NOTE

Procedure is the same for both vehicles except where noted. M915A2 is shown.

1. M915A2: RAISE AND SUPPORT VEHICLE TO ALLOW SUITABLE CLEARANCE BETWEEN OIL PAN AND FRONT AXLE FOR OIL PAN REMOVAL.
2. REMOVE 10 BOLTS (1), 10 ISOLATORS (2), AND 10 SPACER SLEEVES (3) FROM OIL PAN (4).

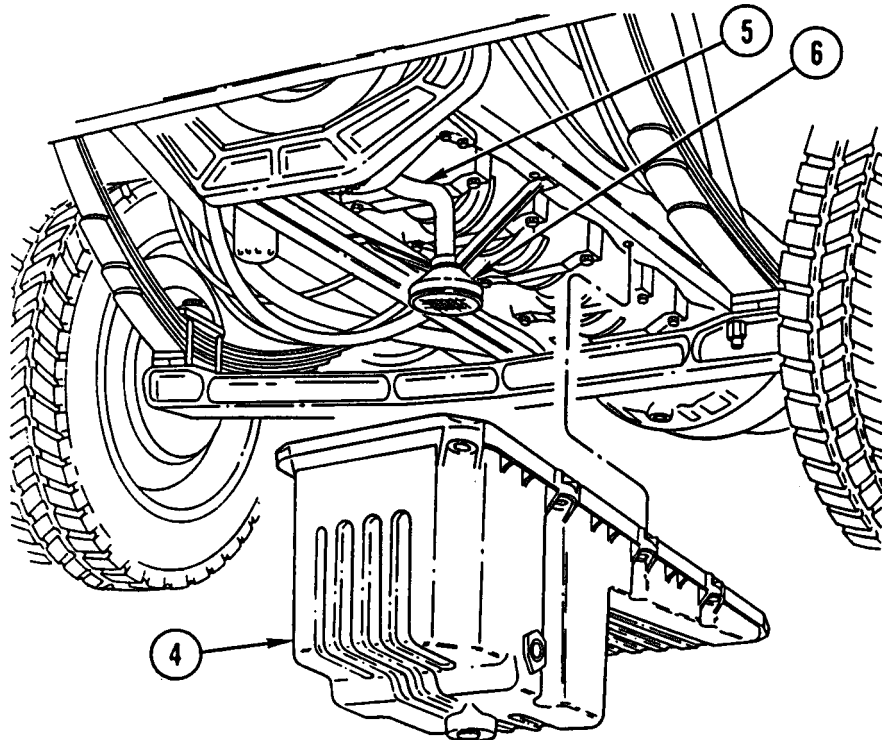
**CAUTION**

Handle oil pan with care. Dropping or bumping could cause unreparable damage.

3. REMOVE OIL PAN (4) CAREFULLY TO AVOID DAMAGE TO OIL PUMP PICKUP TUBE (5) AND SCREEN ASSEMBLY (6).

OIL PAN REPLACEMENT (CONT)

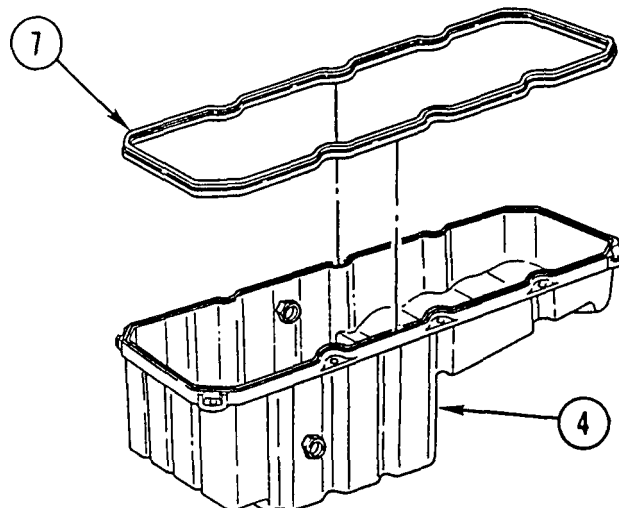

4. REMOVE OIL PAN GASKET (7) FROM OIL PAN (4).

CLEANING

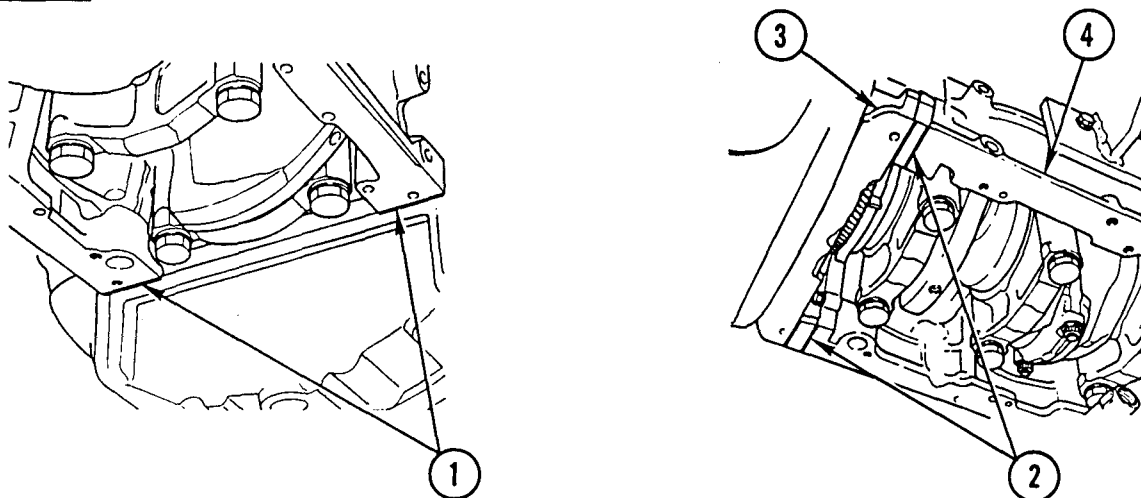

WARNING

To prevent injury, compressed air will not exceed 30 psi (207 kPa). Use only with effective chip guarding and personal protective equipment, goggles, shield, and gloves.

CAUTION

Do not use solvents or petroleum distillates to clean oil pan gasket or isolators. To do so could result in damage to equipment.

1. CLEAN ISOLATORS, OIL PAN, AND OIL PAN GASKET SURFACES WITH MILD SOAP AND WATER. DRY WITH COMPRESSED AIR.

2. REMOVE RTV SEALANT FROM PAN RAIL JOINT FACES OF FLYWHEEL HOUSING (1), GEAR HOUSING (2), GEAR CASE COVER (3), AND CYLINDER BLOCK (4) WHERE CONTACT IS MADE WITH OIL PAN GASKET.
3. MAKE SURE ALL OLD RTV SEALANT IS REMOVED FROM SEALING SURFACES.

INSPECTION

1. MAKE SURE OIL PUMP PICKUP TUBE AND SCREEN ASSEMBLY ARE NOT DAMAGED.
2. CHECK OIL PAN FOR DAMAGE. REPLACE AS NECESSARY.
3. INSPECT BOLT ISOLATORS FOR DRYNESS, CRACKS, OR TEARS. REPLACE AS NECESSARY.

REPAIR

NOTE

For engines prior to S/N 06R0394932, install complete service kit P/N 23521330

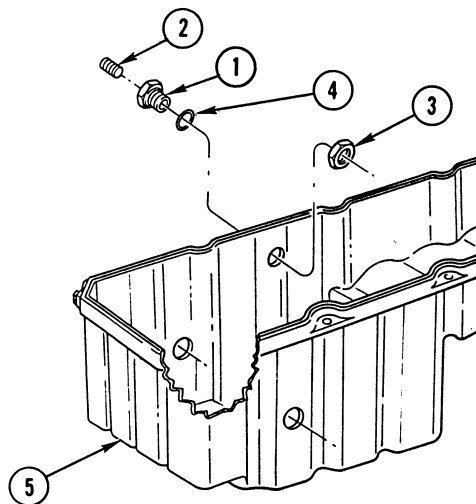

CAUTION

Failure to hold insert while installing nut or pipe plug could allow insert to spin and score plastic side of oil pan.

1. HOLD FLATS OF INSERT (1) TO PREVENT SLIPPAGE AND REMOVE PIPE PLUG (2).
2. REMOVE NUT (3), INSERT (1), AND SEAL RING (4) FROM OIL PAN (5). DISCARD SEAL RING.
3. INSTALL NEW SEAL RING (4) ON FLANGE OF INSERT (1) AND INSTALL INSERT (1) IN OIL PAN (5).
4. INSTALL NUT (3) ON INSERT (1). HOLD FLATS OF INSERT (1) AND TIGHTEN NUT (3) TO 136-145 LB-FT (184-196 N.m).
5. COAT THREADS OF PIPE PLUG (2) WITH PIPE THREAD SEALING COMPOUND AND INSTALL PIPE PLUG (2) IN INSERT.

OIL PAN REPLACEMENT (CONT)

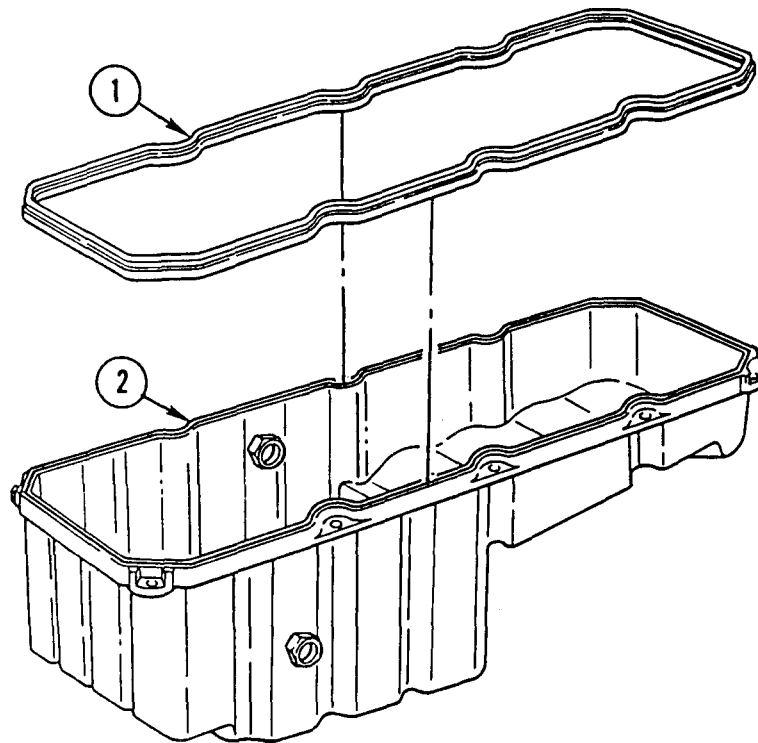

NOTE

Procedure is the same for both vehicles except where noted. M915A2 is shown.

1. PLACE OIL PAN GASKET (1) ON OIL PAN (2) WITH SEAL LIP TOWARD OIL PAN GROOVE.
2. PRESS OIL PAN GASKET (1) COMPLETELY DOWN INTO GROOVE AT EACH CORNER OF OIL PAN (2). REPEAT AT POINTS MIDWAY BETWEEN CORNERS, HALVING DISTANCE BETWEEN INSTALLED SECTIONS UNTIL OIL PAN GASKET (1) IS COMPLETELY INSTALLED.

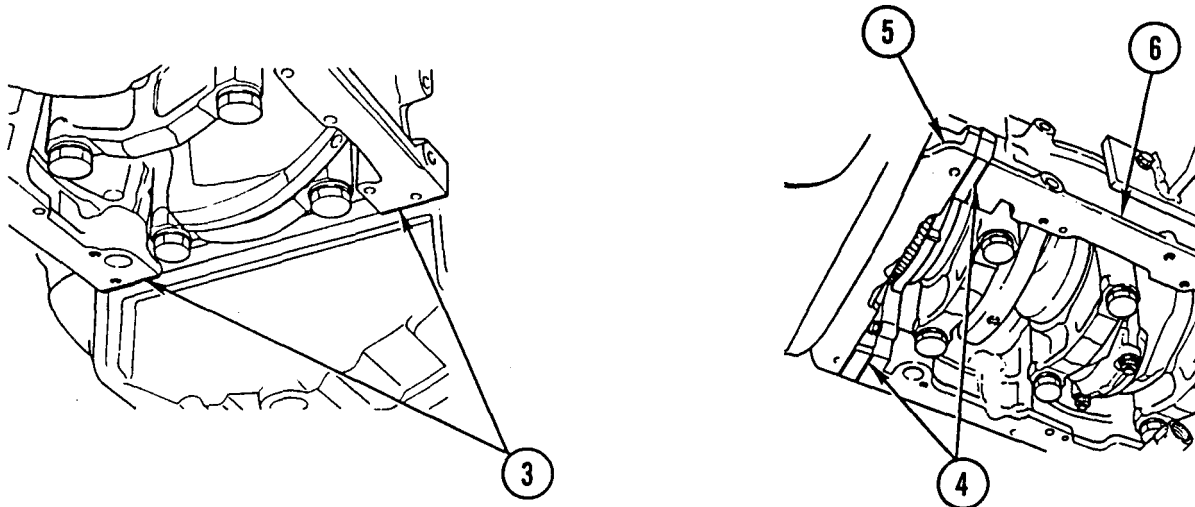

CAUTION

Be careful when installing oil pan. Leaks can occur if RTV sealant rolls, twists, or is otherwise dislodged.

3. APPLY THIN BEAD OF RTV SEALANT TO PAN RAIL JOINT FACES OF FLYWHEEL HOUSING (3), GEAR HOUSING (4), GEAR CASE COVER (5), AND CYLINDER BLOCK (6).

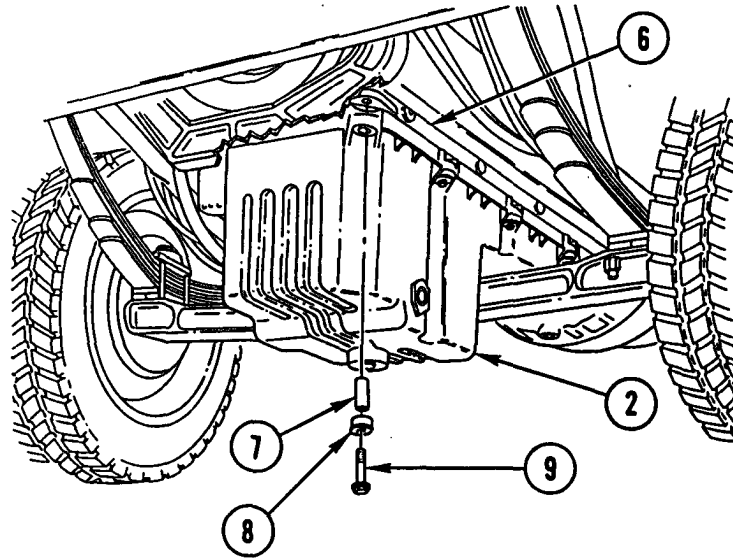
**CAUTION**

Handle oil pan with care. Dropping or bumping could cause unrepairable damage.

NOTE

Be careful not to dislodge oil pan gasket when installing oil pan.

4. INSTALL OIL PAN (2) ON CYLINDER BLOCK (6).
5. INSTALL 10 SPACER SLEEVES (7), 10 ISOLATORS (8), AND 10 BOLTS (9).

OIL PAN REPLACEMENT (CONT)

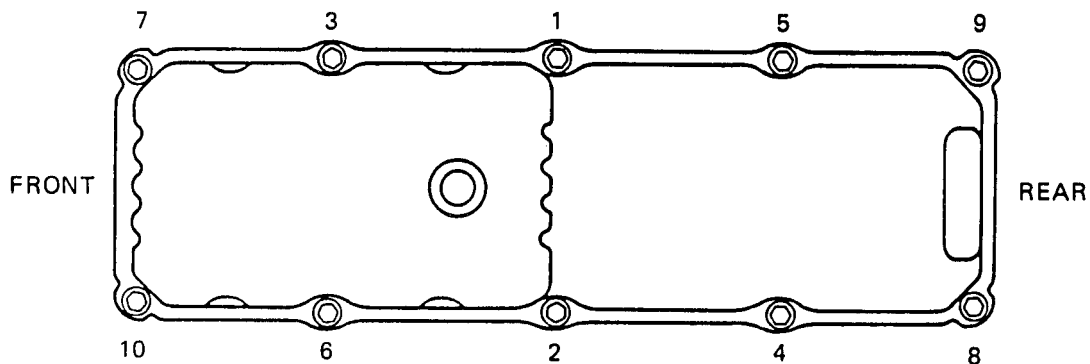

CAUTION
Check position of spacer sleeves before tightening bolts.

6. TIGHTEN OIL PAN RETAINING BOLTS TO 18-22 LB-FT (25-30 N.m) IN SEQUENCE SHOWN.

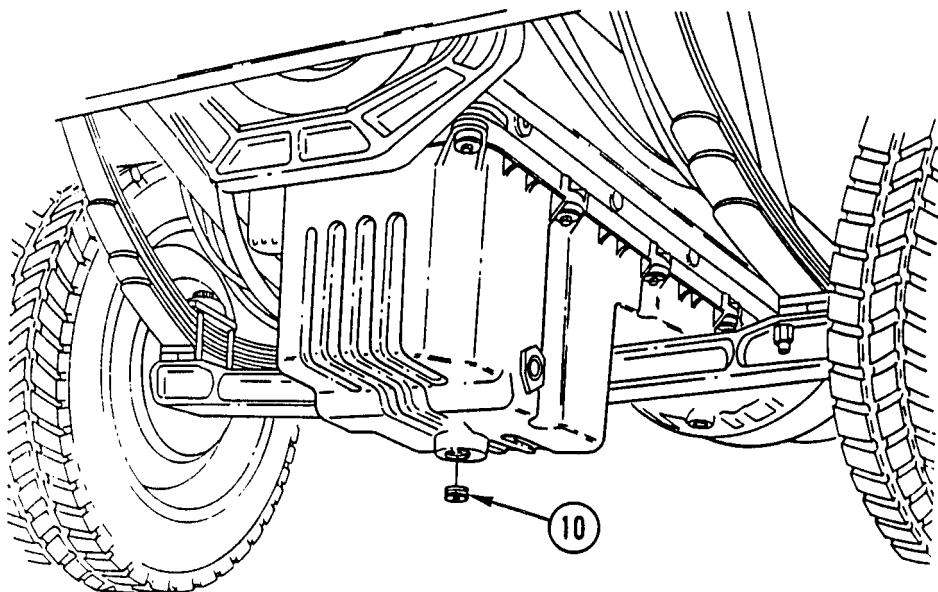

7. INSTALL OIL PAN DRAIN PLUG (10) AND TIGHTEN TO 33-37 LB-FT (45-50 N.m).
8. M915A2: LOWER VEHICLE TO GROUND.

NOTE

Follow-on Maintenance:
Fill oil pan with engine lubricating oil (LO 9-2320-363-12).

CRANKSHAFT FRONT OIL SEAL REPLACEMENT

This task covers: a. Removal b. Inspection c. Installation

INITIAL SETUP

Tools and Special Equipment:

Shop Equipment, SC 4910-95-CL-A31
 Tool Kit, SC 5180-90-CL-N05
 Oil Seal Remover, J35993
 (XI Seal Installer, J35686
 Oil Seal Expander, J35685-A

Equipment Condition:

Reference

Page 3-122

Condition Description

Vibration Damper
 Removed

Materials/Parts:

Seal, Crankshaft Front Oil	P/N Y327958TA
Cloth, Abrasive	Appendix B, Item 10
Oil, Lubricating	Appendix B, Item 37

CRANKSHAFT FRONT OIL SEAL REPLACEMENT (CONT)

REMOVAL

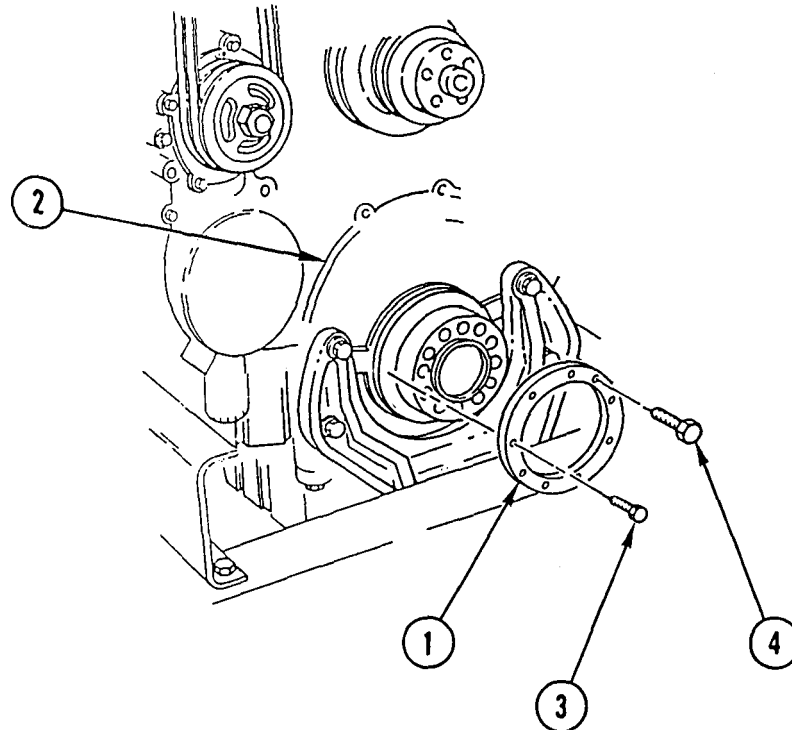

NOTE

Make sure screws are evenly snug against oil seal remover, but not overtightened or stripped in seal case.

1. INSTALL OIL SEAL REMOVER (1) OVER END OF CRANKSHAFT AND AGAINST GEAR CASE COVER (2). INSTALL SIX SELF-TAPPING SCREWS (3).
2. INSTALL THREE BOLTS (4) IN OIL SEAL REMOVER (1) UNTIL BOLTS (4) CONTACT GEAR CASE COVER (2).

NOTE

If self-tapping screws strip out of seal case, remove six self-tapping screws and three bolts. Rotate oil seal remover one-half distance between existing screw holes in seal case and repeat steps 1 thru 3.

3. WORK CLOCKWISE AND TURN THREE BOLTS (4), ONE AT A TIME, ONE FULL TURN UNTIL OIL SEAL IS REMOVED.

INSPECTION**NOTE**

Minor wear line on crankshaft surface should be evident where contact was made with oil seal. This is normal.

1. INSPECT OIL SEAL CONTACT SURFACE OF CRANKSHAFT CAREFULLY.
2. INSPECT EXPOSED AREA OF CRANKSHAFT FOR DIRT, BURRS, OR ROUGH SURFACES.
3. IF NECESSARY, CLEAN CRANKSHAFT SURFACE WITH ABRASIVE CLOTH.

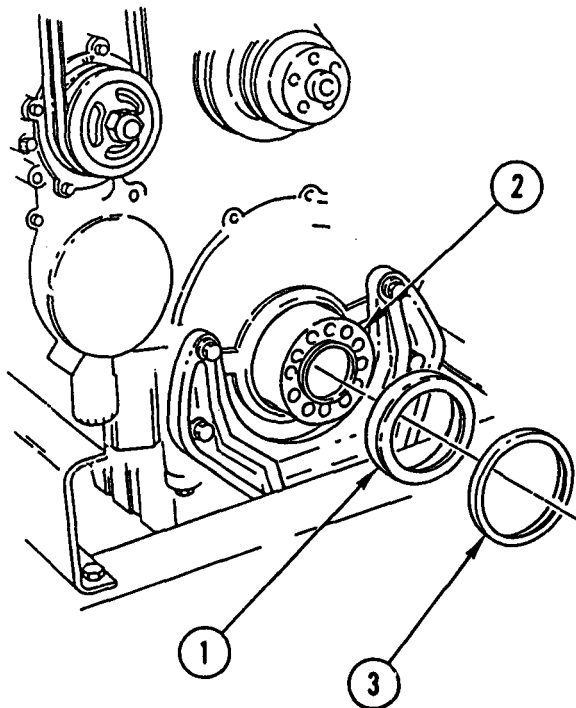
INSTALLATION

1. COAT OUTSIDE OF OIL SEAL EXPANDER (1) WITH LIGHT FILM OF CLEAN ENGINE LUBRICATING OIL AND INSTALL EXPANDER (1) ON END OF CRANKSHAFT (2).

NOTE

Before installing oil seal, direction of arrow on oil seal should match engine rotation.

2. INSTALL OIL SEAL (3) OVER OIL SEAL EXPANDER (1) AND ONTO CRANKSHAFT (2) CAREFULLY, AS FAR AS IT WILL GO MANUALLY.
3. REMOVE OIL SEAL EXPANDER (1).

CRANKSHAFT FRONT OIL SEAL REPLACEMENT (CONT)

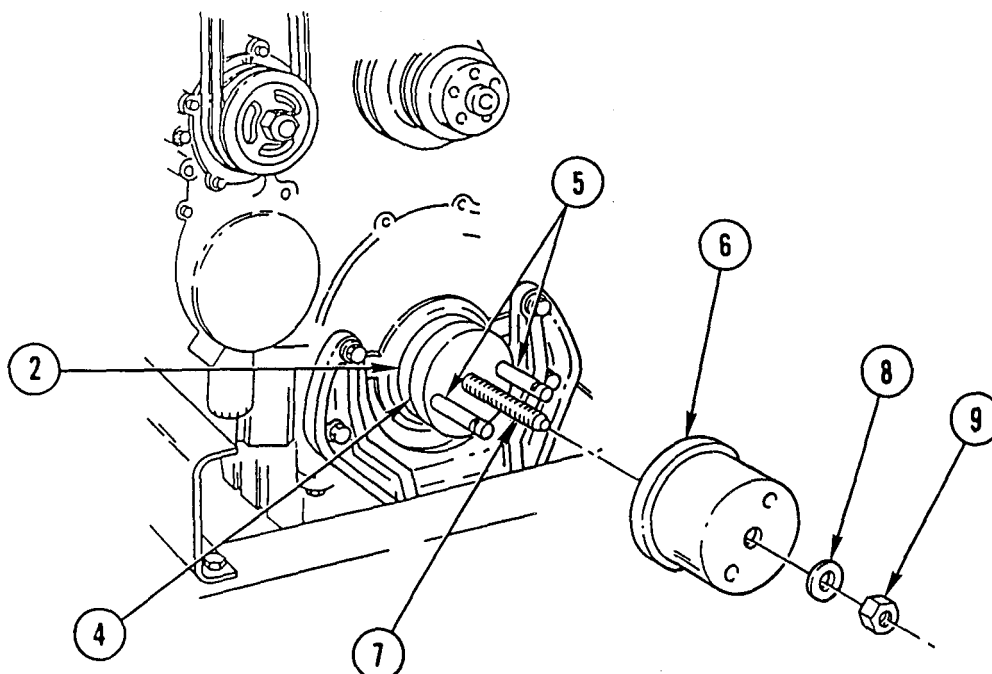

NOTE

Make sure butt end of crankshaft, both sides of base, and inside of installer housing are clean, smooth, and free of foreign material or damage.

4. POSITION OIL SEAL INSTALLER BASE (4) ON FRONT OF CRANKSHAFT (2).
5. INSTALL TWO GUIDE STUDS (5) THRU TWO HOLES IN INSTALLER BASE (4) AND INTO TWO CRANKSHAFT PULLEY/VIBRATION DAMPER MOUNTING BOLT HOLES 180 DEGREES APART.
6. HAND-TIGHTEN TWO GUIDE STUDS (5) UNTIL INSTALLER BASE (4) IS TIGHT AGAINST END OF CRANKSHAFT (2).
7. INSTALL OIL SEAL INSTALLER HOUSING (6) OVER CENTER SCREW (7) OF INSTALLER BASE (4) AND TWO GUIDE STUDS (5) AND AGAINST OIL SEAL.
8. INSTALL THRUST BEARING (8) ON CENTER SCREW (7) WITH CASE SIDE OF THRUST BEARING AGAINST OIL SEAL INSTALLER HOUSING (6).
9. INSTALL AND TIGHTEN OIL SEAL INSTALLER NUT (9) UNTIL INSIDE SURFACE OF OIL SEAL INSTALLER HOUSING (6) IS FIRMLY SEATED AGAINST INSTALLER BASE (4).
10. REMOVE OIL SEAL INSTALLER NUT (9), THRUST BEARING (8), OIL SEAL INSTALLER HOUSING (6), TWO GUIDE STUDS (5), AND OIL SEAL INSTALLER BASE (4).

NOTE

Follow-on Maintenance:

install vibration damper (page 3-122).

CRANKSHAFT OVERSIZE FRONT OIL SEAL REPLACEMENT

This task covers: a. Removal b. Inspection c. Installation

Tools and Special Equipment:

Shop Equipment, SC 4910-95-CL-A31
 Tool Kit, SC 5180-90-CL-N05
 Oil Seal Remover, J35993
 Oil Seal Installer, J35686
 Oil Seal Expander, J35685-A

Equipment Condition:

Reference

Page 3-116

Condition Description

Gear Case Cover
 Removed

Materials/Parts:

Seal	P/N Y327984TA
Sleeve	P/N J-2037
Cloth, Abrasive	Appendix B, Item 10
Oil, Lubricating	Appendix B, Item 37

REMOVAL

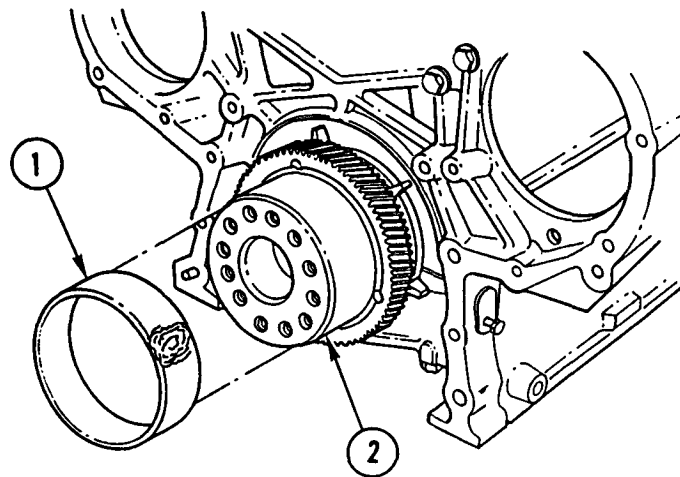

CAUTION

Be careful not to damage crankshaft surface when peening wear sleeve. Do not use puller or cut sleeve to remove wear sleeve.

REMOVE AND DISCARD CRANKSHAFT WEAR SLEEVE (1) FROM FRONT OIL SEAL CRANKSHAFT (2) CONTACT AREA. PEEN OUTSIDE CRANKSHAFT WEAR SLEEVE DIAMETER CAREFULLY UNTIL IT STRETCHES ENOUGH TO SLIDE OFF CRANKSHAFT (2).

CRANKSHAFT OVERSIZE FRONT OIL SEAL REPLACEMENT (CONT)

INSPECTION

NOTE

Wear line on crankshaft should be evident where contact was made with oil seal,

1. INSPECT OIL SEAL CONTACT SURFACE OF CRANKSHAFT CAREFULLY.
2. INSPECT EXPOSED AREA OF CRANKSHAFT FOR DIRT, BURRS, OR ROUGH SURFACES.
3. IF NECESSARY, CLEAN CRANKSHAFT SURFACE WITH ABRASIVE CLOTH.

INSTALLATION

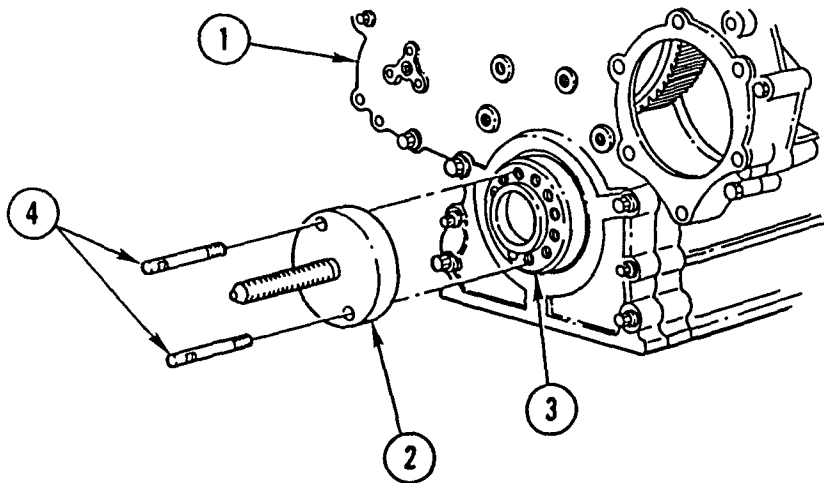

1. INSTALL GEAR CASE COVER (1) (PAGE 3-116).

CAUTION

Make sure gear case cover seal bore, front of crankshaft, and both sides of oil seal installer base are clean, smooth, and free of any foreign material or damage to prevent damage to equipment.

2. POSITION OIL SEAL INSTALLER BASE (2) ON CRANKSHAFT (3).
3. INSTALL TWO GUIDE STUDS (4) IN TWO CRANKSHAFT (3) BOLT HOLES 180 DEGREES APART.
4. HAND-TIGHTEN TWO GUIDE STUDS (4) UNTIL INSTALLER BASE (2) IS TIGHT AGAINST FRONT OF CRANKSHAFT (3).

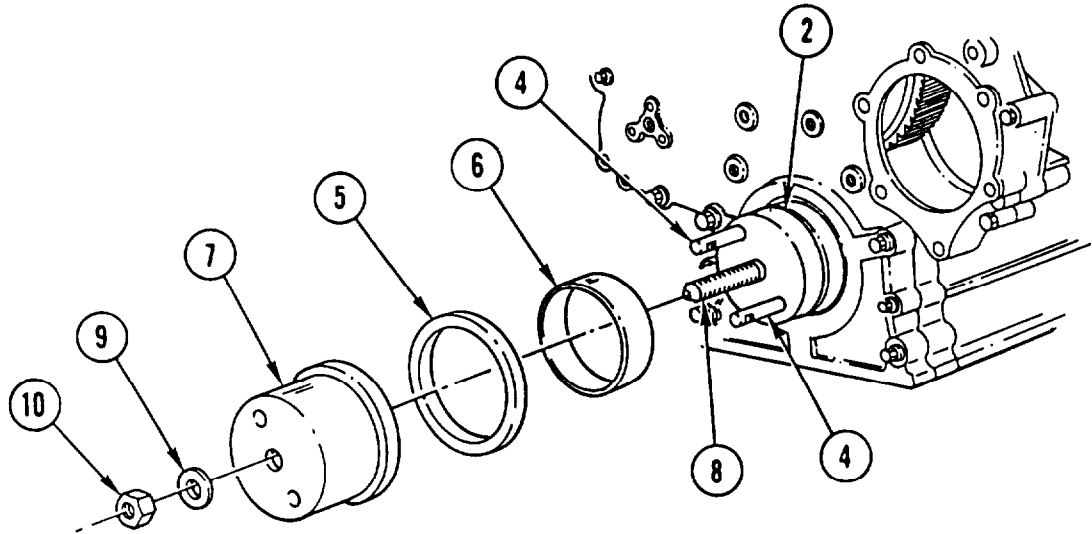
**NOTE**

Before oil seal installation, direction of arrow on oil seal should match engine rotation.

5. CAREFULLY INSTALL NEW OVERSIZED CRANKSHAFT OIL SEAL (5) ON NEW WEAR SLEEVE (6) FROM CHAMFERED END OF SLEEVE. POSITION OIL SEAL (5) IN MIDDLE OF SLEEVE (6) WITH CASE SIDE OF SEAL AWAY FROM CHAMFERED END OF SLEEVE.
6. POSITION AND INSTALL OIL SEAL AND SLEEVE ASSEMBLY IN OIL SEAL INSTALLER HOUSING (7) WITH SEAL CASING AGAINST INSTALLER HOUSING.
7. PLACE OIL SEAL INSTALLER HOUSING (7) WITH OIL SEAL AND SLEEVE ASSEMBLY OVER CENTER SCREW (8) AND TWO GUIDE STUDS (4) AND POSITION SLEEVE (6) AGAINST FRONT OF CRANKSHAFT.
8. INSTALL THRUST BEARING (9) ON CENTER SCREW (8) WITH LETTERED SIDE OF BEARING AGAINST OIL SEAL INSTALLER HOUSING (7).
9. INSTALL NUT (10) ON CENTER SCREW (8). TIGHTEN NUT UNTIL CRANKSHAFT FRONT OIL SEAL AND SLEEVE ARE SEATED FIRMLY.
10. REMOVE OIL SEAL INSTALLER NUT (10), THRUST BEARING (9), INSTALLER HOUSING (7), GUIDE STUDS (4), AND INSTALLER BASE (2).

NOTE

Follow-on Maintenance:

- Install front mount (page 3-46).
- Install vibration damper (page 3-122).
- Install tachometer cable (TM 9-2320-363-20).
- Install power steering pump (page 7-2).
- Install accessory drive (page 3-126).
- Install alternator (TM 9-2320-363-20).

**Section II. TRANSMISSION AND TRANSFER CASE REMOVAL
AND INSTALLATION**

OVERVIEW

This section illustrates and describes procedures for removal and installation of the transmission and transfer case and related parts. A list of tasks contained in this section is shown below.

	Page
Transmission Replacement	3-235
Transmission Output Yoke Replacement and Repair	3-256
Internal Filter Element Replacement	3-258
Governor Service and Replacement	3-260
Modulator Valve Replacement	3-261
Lockup Cutoff Control Valve Replacement	3-262
Transfer Case Replacement (All Except M915A2)	3-263
Transfer Case Mounts Replacement (All Except M915A2)	3-269.0
Air Shift Chamber Replacement (All Except M915A2)	3-270
Transfer Case Yoke and Oil Seal Replacement (All Except M915A2)	3-274
Lubrication Pump Replacement (All Except M915A2)	3-276

TRANSMISSION REPLACEMENT

This task covers: a. Removal b. Cleaning c. Inspection d. Installation

INITIAL SETUP

Tools and Special Equipment:

Shop Equipment, SC 4910-95CL-A31
 Tool Kit, SC 5180-90-CL-N05
 Shop Equipment, SC 5180-95-CL-A62

Materials/Parts:

Kit, Mounting P/N 328170-101X
 Gasket P/N 23016683
 Nut, Lock (2)
 Washer, Lock (2)
 Washer, Lock (15) P/N 103323
 Washer, Lock
 Tag, Identification Appendix B, Item 55

Personnel Required: (2)

References:

TM 9-2320-363-10
 TM 9-2320-363-20

Equipment Condition:

Reference	Condition Description
TM 9-2320-363-10	Transfer Case Shift Selector Set to Neutral (M916A1)
TM 9-2320-363-10	Spare Tire Removed
TM 9-2320-363-20	Transmission Dipstick Tube Removed
TM 9-2320-363-20	Passenger Seal Removed
TM 9-2320-363-20	Batteries Disconnected
TM 9-2320-363-20	Transmission Tunnel Access Cover Removed
TM 9-2320-363-20	Transmission Shift Control Removed

Equipment Condition: (Cont)

Reference	Condition Description
TM 9-2320-363-20	Air System Drained
TM 9-2320-363-20	Drivelines Removed
TM 9-2320-363-20	Transmission Fluid Drained

General Safety Instructions:

WARNING

- Do not disconnect any air system lines or fittings unless vehicle engine is shut off and air system pressure is relieved. To do so could result in serious injury to personnel.
- Transmission weighs 900 lb (409 kg). Support transmission with transmission jack during removal or installation to prevent possible injury to personnel.
- Do not place finger in hole of engine flywheel housing while engine is being barred over. To do so could result in serious injury to personnel.
- Oil filter mounting bracket assembly weighs 22 lb (10 kg). Support mounting bracket assembly prior to removal to prevent injury to personnel.

TRANSMISSION REPLACEMENT (CONT)

REMOVAL

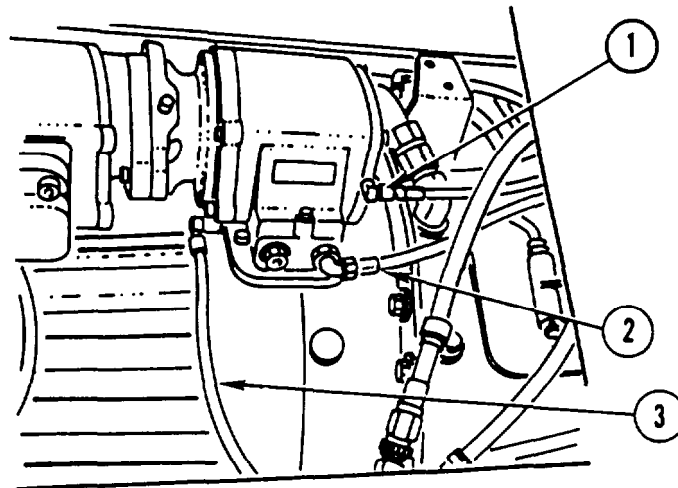

WARNING

Do not disconnect any air system lines or fittings unless vehicle engine is shut off and air system pressure is relieved. To do so could result in serious injury to personnel.

NOTE

- Tag all fluid lines, air lines, and electrical connectors prior to removal to aid in installation.
- If transmission is being replaced because of clutch or gear failure, external filter must be replaced and cooler hoses and cooler must be flushed and blown out.
- Steps 1 thru 6 are for all except M915A2.

1. FROM INSIDE CAB, THRU ACCESS HOLE, DISCONNECT TWO AIR HOSES (1 AND 2) AND LUBRICATION HOSE (3).

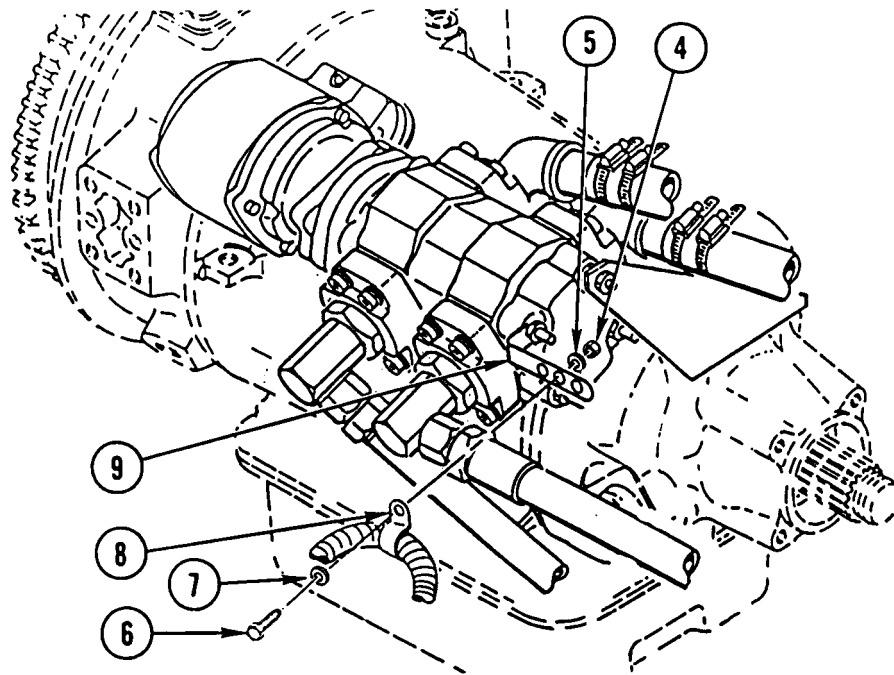

2. REMOVE LOCK NUT (4), WASHER (5), SCREW (6), WASHER (7), AND CLAMP (8) FROM BRACKET (9). DISCARD LOCK NUT.

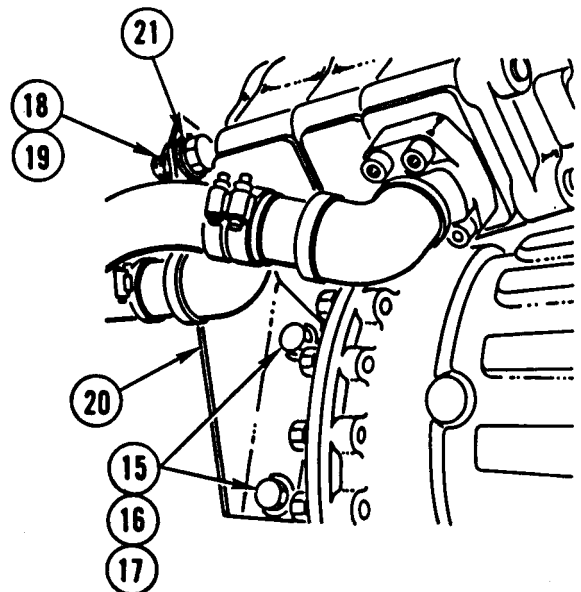
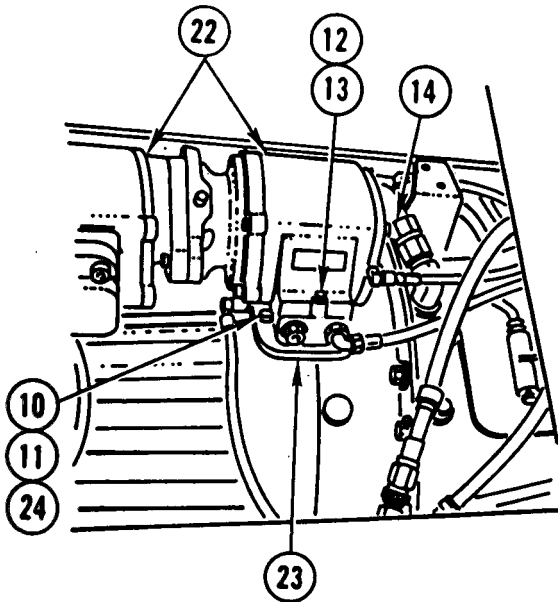

3. REMOVE FIVE NUTS (10), FIVE COPPER GASKETS (11), CAPSCREW (12), WASHER (13), AND HOSE (14). DISCARD NUTS AND GASKETS.
4. REMOVE TWO BOLTS (15), TWO LOCK WASHERS (16), TWO WASHERS (17), LOCK NUT (18), WASHER (19), BRACKET (20), AND THREE WASHERS (21). DISCARD LOCK WASHERS AND LOCK NUT.
5. LIFT AND SECURE PTO-HYDRAULIC PUMP COMBINATION (22).
6. REMOVE AND DISCARD PTO GASKET (23) AND FIVE STUDS (24).

TRANSMISSION REPLACEMENT (CONT)

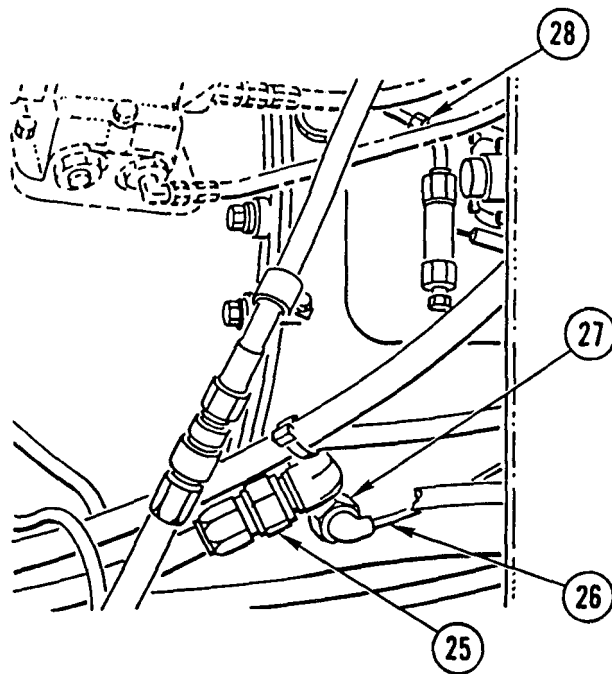

- 7. DISCONNECT OIL COOLER HOSE (25).
- 8. DISCONNECT ELECTRICAL CABLE (26) FROM TEMPERATURE SENDING UNIT (27).
- 9. DISCONNECT AIR HOSE (28).

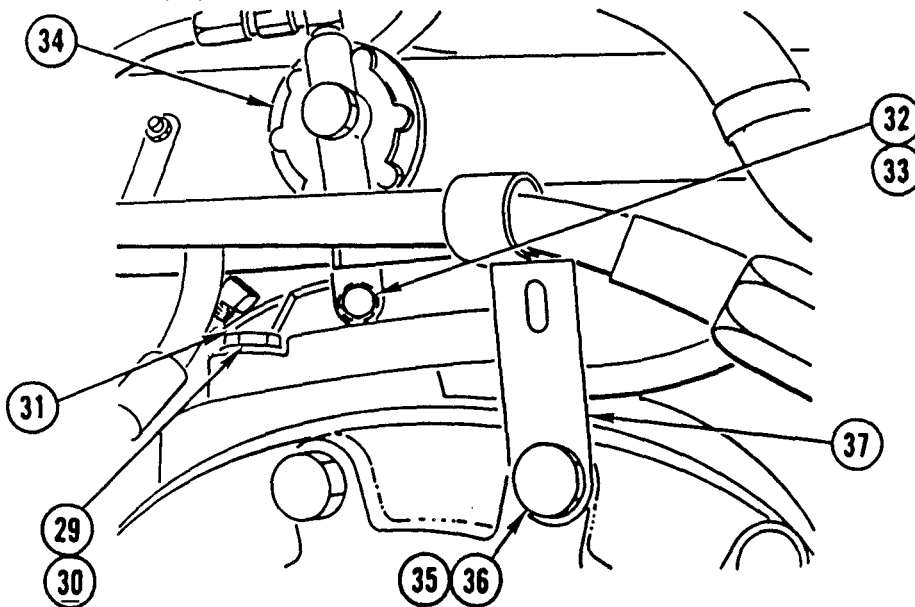

- 10. REMOVE BOLT (29) AND WASHER (30) AND DISCONNECT GROUND STRAP (31). INSTALL WASHER (30) AND BOLT (29).

11. REMOVE BOLT (32) AND LOCK WASHER (33) AND SET PRESSURE REGULATOR SOLENOID VALVE (34) ASIDE. NOTE BOLT (32) POSITION FOR LATER USE. DISCARD LOCK WASHER.
12. REMOVE BOLT (35) AND LOCK WASHER (36) AND SET BRACKET (37) ASIDE. NOTE BOLT (35) POSITION FOR LATER USE. DISCARD LOCK WASHER.

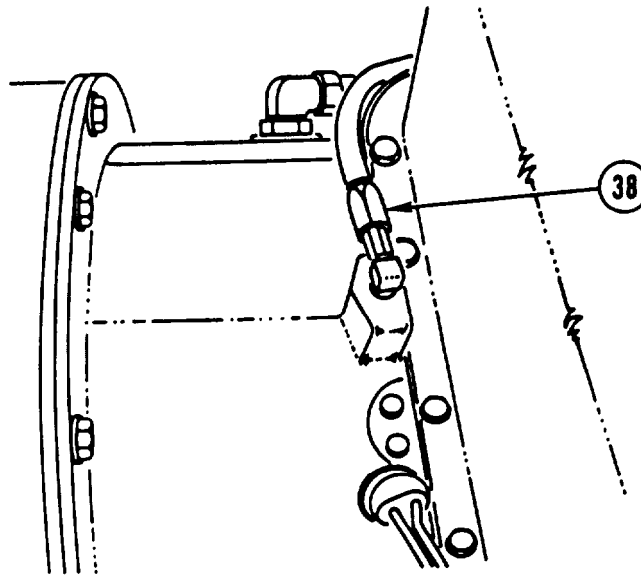

NOTE

Steps 13 and 14 are for all except M915A2.

13. DISCONNECT HOSE (38).

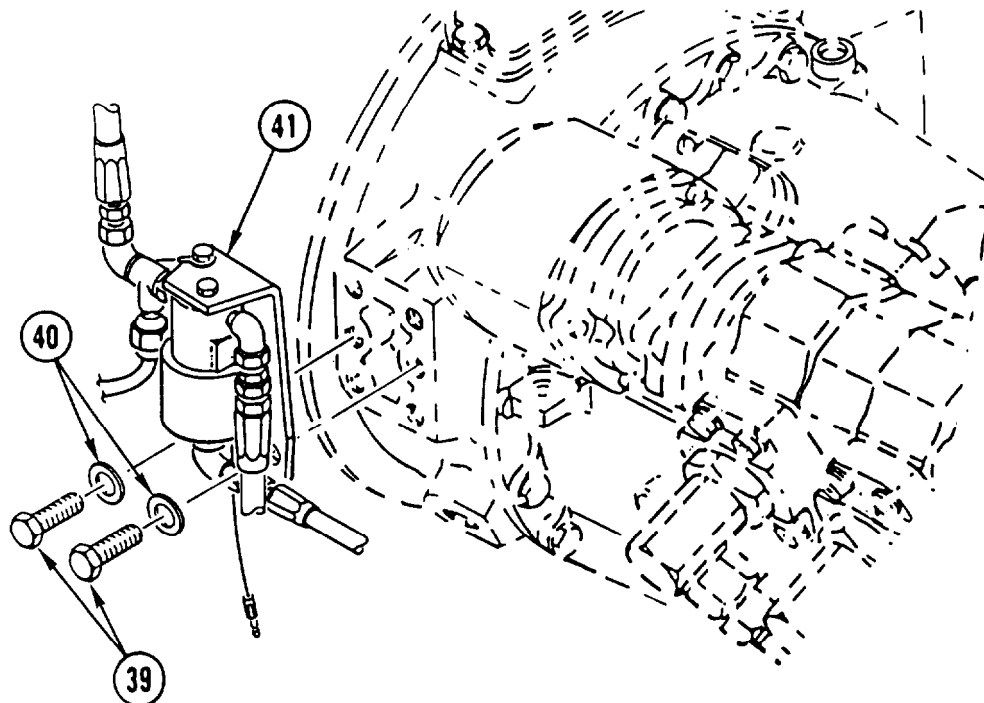

14. REMOVE TWO BOLTS (39) AND TWO WASHERS (40) AND SET SWING BRACKET (41) ASIDE.

TRANSMISSION REPLACEMENT (CONT)

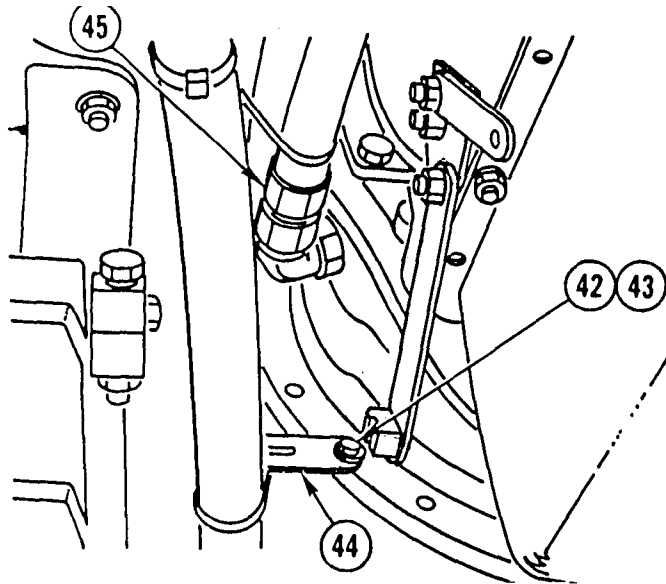

15. REMOVE BOLT (42) AND LOCK WASHER (43) AND SET BRACKET (44) ASIDE. NOTE BOLT (42) POSITION FOR LATER USE. DISCARD LOCK WASHER.

16. DISCONNECT HYDRAULIC HOSE (45).

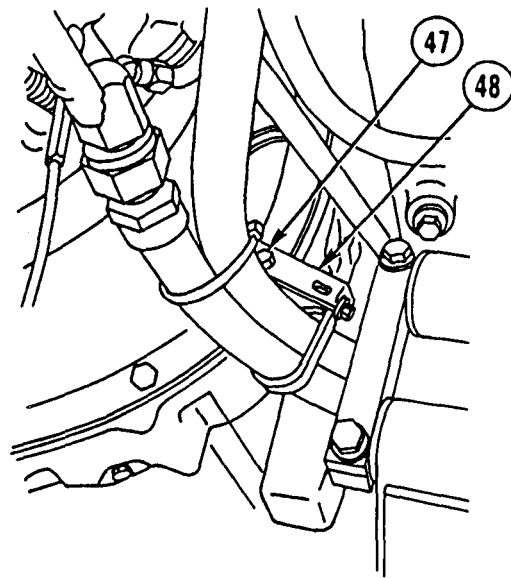
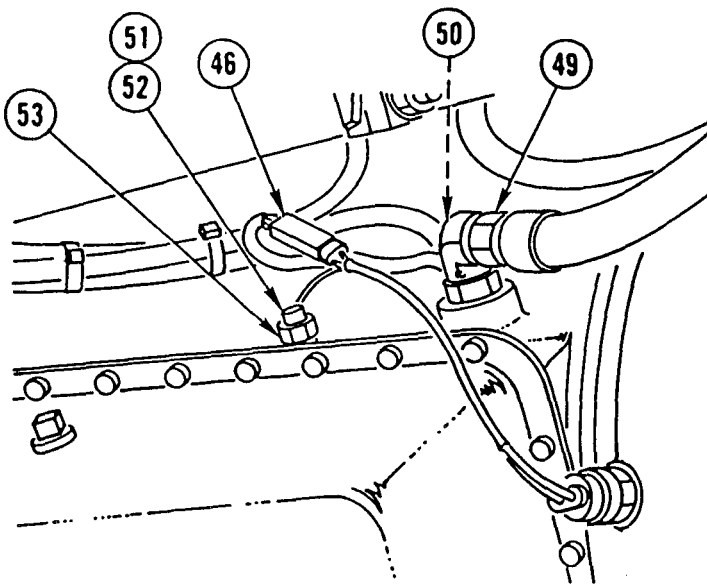

17. DISCONNECT ELECTRICAL CONNECTOR (46).

NOTE

Step 18 is for M915A2 only.

18. REMOVE BOLT (47) AND BRACKET (48). NOTE BOLT (47) POSITION FOR LATER USE.
19. DISCONNECT HYDRAULIC HOSE (49).
20. DISCONNECT OIL SAMPLE HOSE (50).
21. REMOVE TWO SCREWS (51) AND DISCONNECT TWO CABLES (52) FROM REVERSE SENDING UNIT (53).

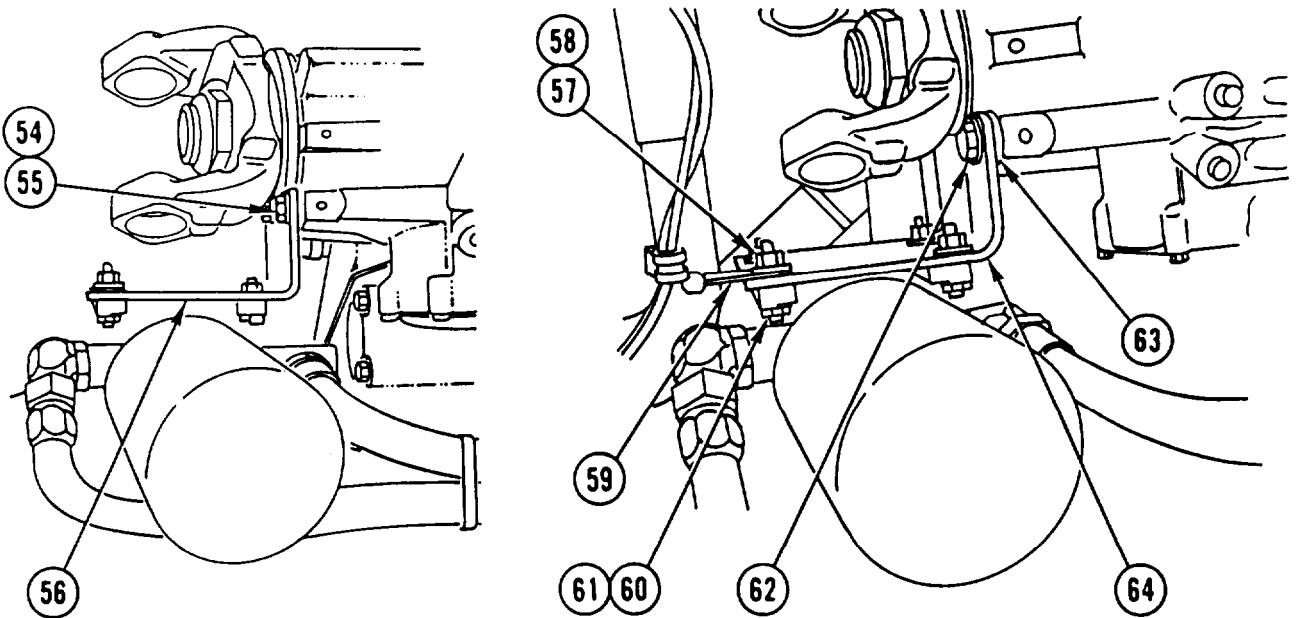

NOTE

Step 22 is for M915A2 only.

22. REMOVE TWO BOLTS (54), TWO WASHERS (55), AND OIL FILTER MOUNTING BRACKET (56).
23. REMOVE NUT (57), WASHER (58), BRACKET (59), BOLT (60), AND WASHER (61).

WARNING

Oil filter mounting bracket assembly weighs 22 lb (10 kg). Support mounting bracket assembly prior to removal to prevent injury to personnel.

NOTE

Step 24 is for all except M915A2.

24. REMOVE TWO BOLTS (62), SPACER (63), AND OIL FILTER MOUNTING BRACKET (64).

TRANSMISSION REPLACEMENT (CONT)

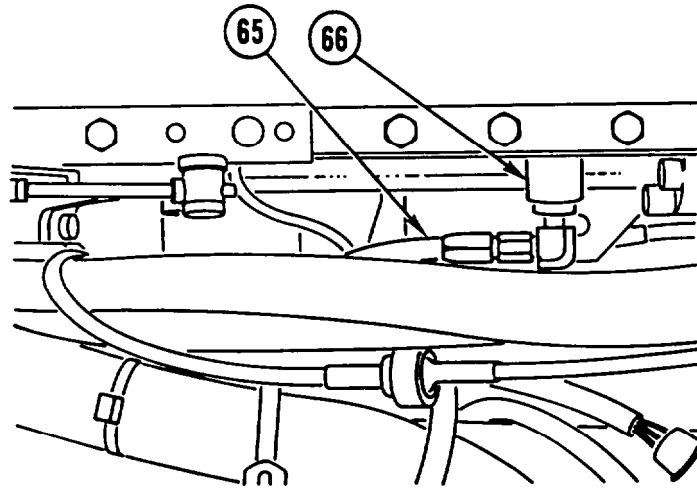

25. DISCONNECT HOSE (65) FROM GOVERNOR (66).

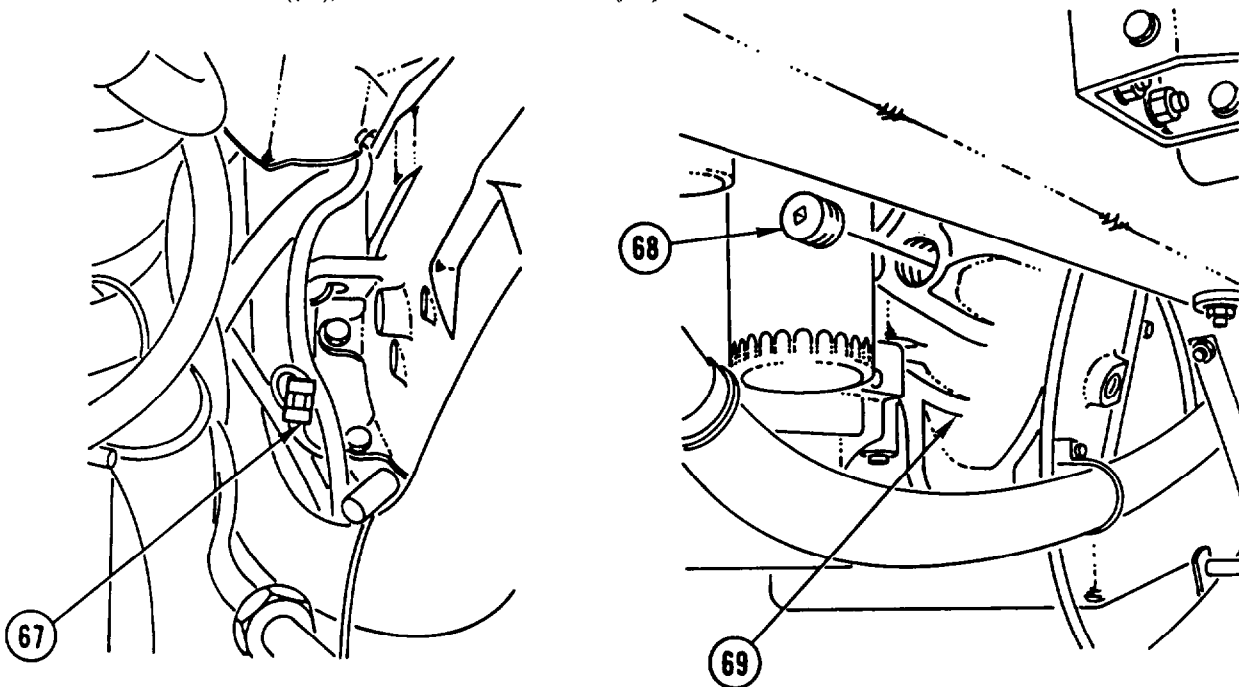

26. DISCONNECT ELECTRICAL CONNECTOR (67).

27. REMOVE PLUG (66) FROM ENGINE FLYWHEEL HOUSING (69).

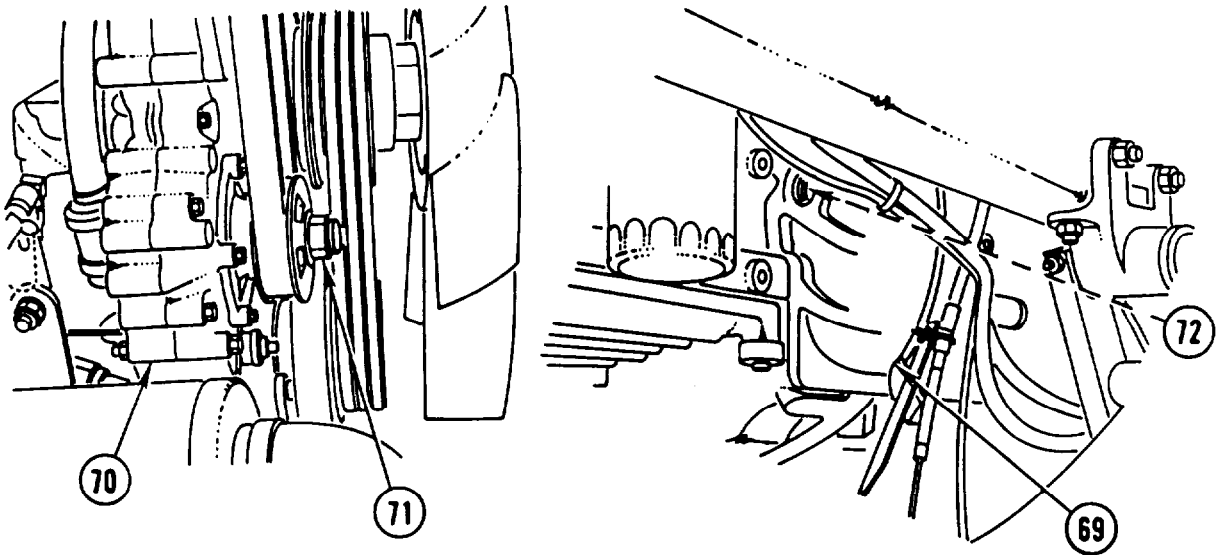
**WARNING**

Do not place finger in hole of engine flywheel housing while engine is being barred over. To do so could result in serious injury to personnel.

CAUTION

Step 28 must be followed in barring engine over. Any other method may damage equipment.

28. HAVE ASSISTANT BAR ENGINE (70) OVER USING ACCESSORY DRIVE (71). USING INSPECTION MIRROR, LOCATE BOLT (72). HAVE ASSISTANT STOP BARRING ENGINE OVER. REMOVE BOLT (72) THRU HOLE IN ENGINE FLYWHEEL HOUSING (69). REPEAT UNTIL 12 BOLTS (72) HAVE BEEN REMOVED.

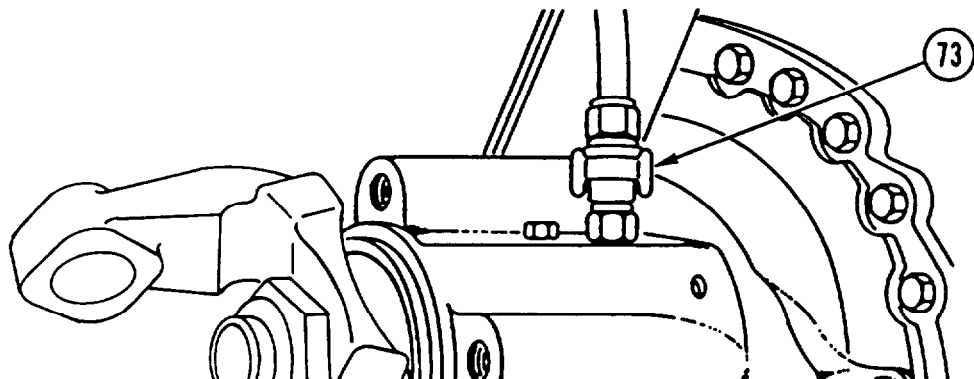
**NOTE**

Step 29 is for M915A2 only.

29. DISCONNECT SPEEDOMETER CABLE (73).

TRANSMISSION REPLACEMENT (CONT)

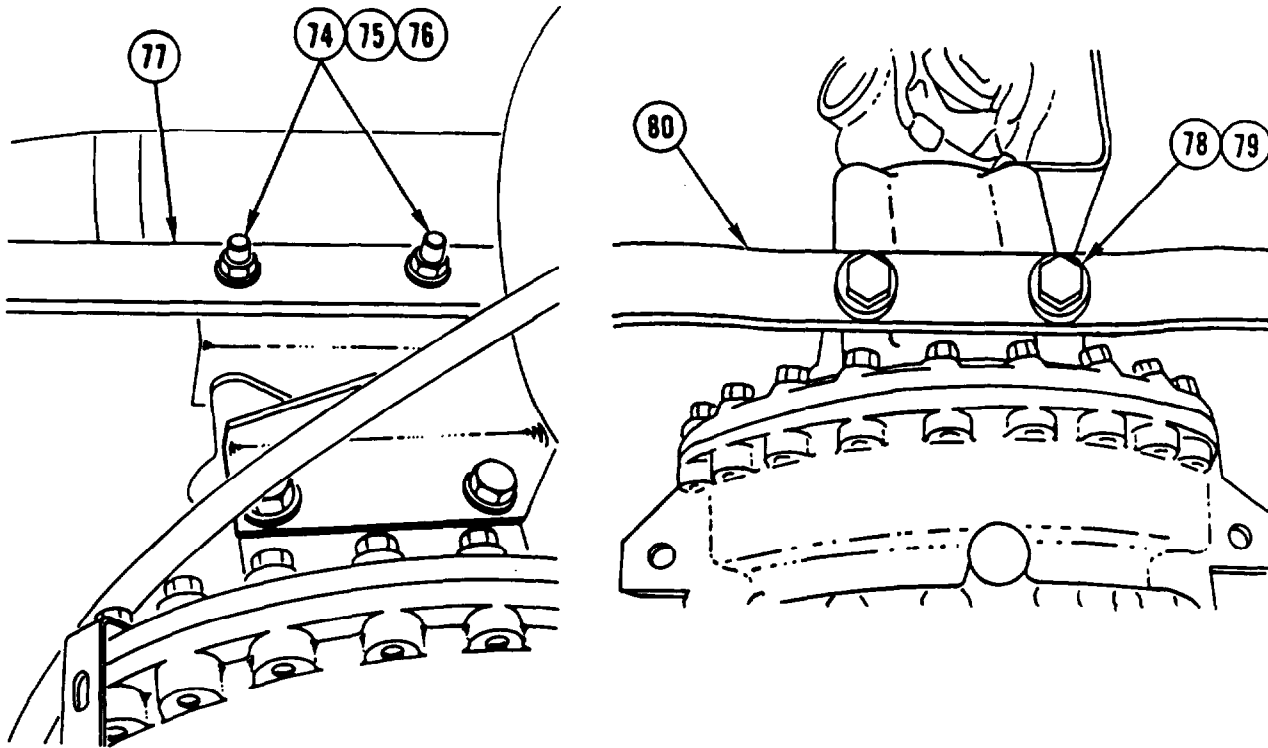

WARNING

Transmission weighs 900 lb (409 kg). Support transmission with transmission jack during removal to prevent possible injury to personnel.

NOTE

Step 30 is for all except M915A2. Step 31 is for M915A2.

30. REMOVE TWO NUTS (74), TWO WASHERS (75), TWO BOLTS (76), AND SUPPORT SPRING (77).

31. REMOVE TWO BOLTS (78), TWO WASHERS (79), AND SUPPORT SPRING (80).

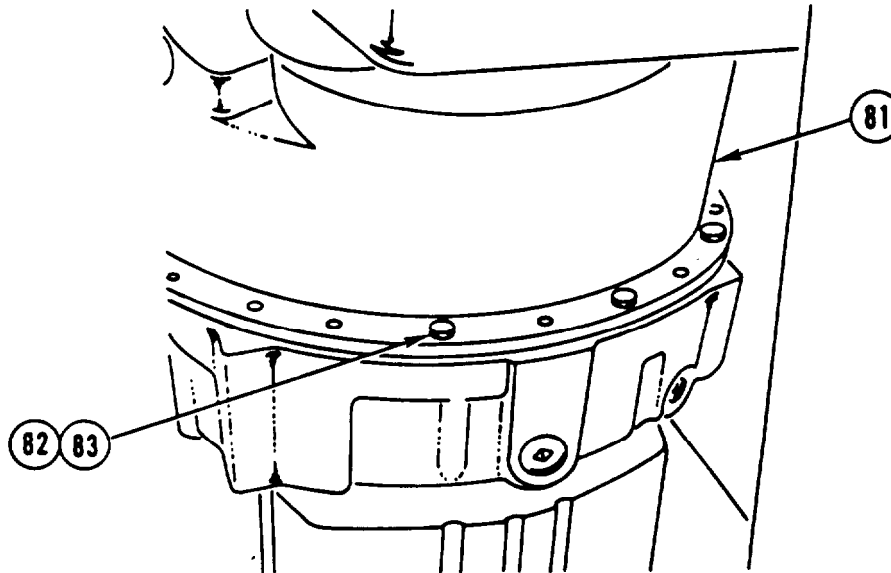

32. USING TRANSMISSION JACK, SUPPORT TRANSMISSION (81) AND REMOVE 10 BOLTS (82) AND 10 LOCK WASHERS (83). DISCARD LOCK WASHERS.

NOTE

It may be necessary to jack vehicle up so transmission will clear.

33. LOWER TRANSMISSION (81) AND ROLL FROM UNDER VEHICLE.

CLEANING

Use general cleaning methods to clean all parts (page 2-30).

INSPECTION

Inspect all parts for wear or damage.

TRANSMISSION REPLACEMENT (CONT)

INSTALLATION

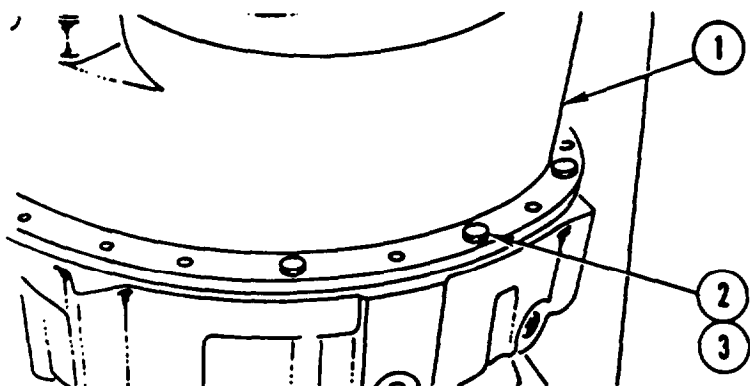

WARNING
 Transmission weighs 900 lb (409 kg). Support transmission with transmission jack during installation to prevent possible injury to personnel.

1. USING TRANSMISSION JACK, ROLL TRANSMISSION (1) INTO PLACE UNDER VEHICLE.

CAUTION
 Transmission must be seated squarely against flywheel housing to prevent damage to equipment.

2. INSTALL TRANSMISSION (1), 12 NEW LOCK WASHERS (2), AND 12 BOLTS (3). HAND-TIGHTEN BOLTS.
3. TIGHTEN FOUR BOLTS (3) 90 DEGREES APART TO 40 LB-FT (54 N.m).
4. TIGHTEN 12 BOLTS (3) TO 40 LB-FT (54 N.m).

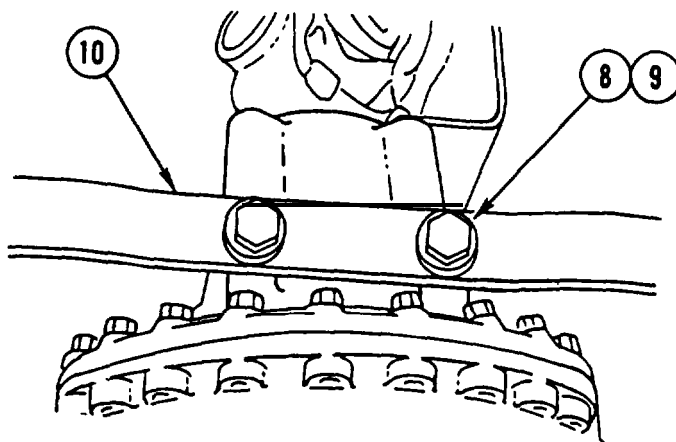
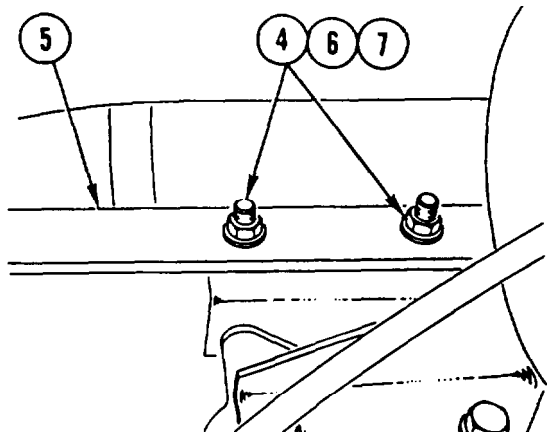

NOTE

Step 5 is for all except M915A2. Step 6 is for M915A2.

5. INSTALL TWO BOLTS (4), SUPPORT SPRING (5), TWO WASHERS (6), AND TWO NUTS (7).

6. INSTALL TWO BOLTS (8), TWO WASHERS (9), AND SUPPORT SPRING (10).

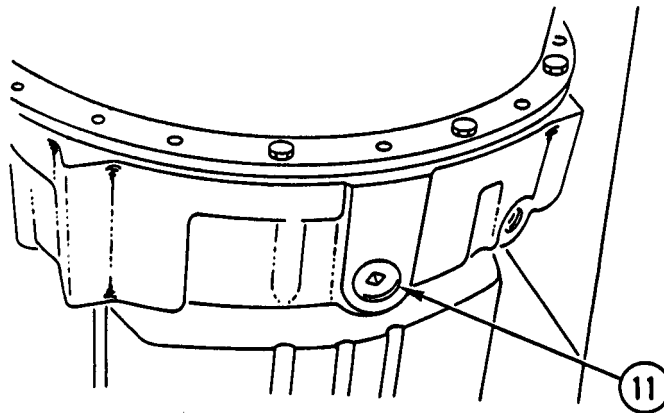

7. REMOVE PLUG (11) AND ROTATE TORQUE CONVERTOR TO ALINE HOLES IN FLEX PLATE WITH HOLES IN TORQUE CONVERTOR.

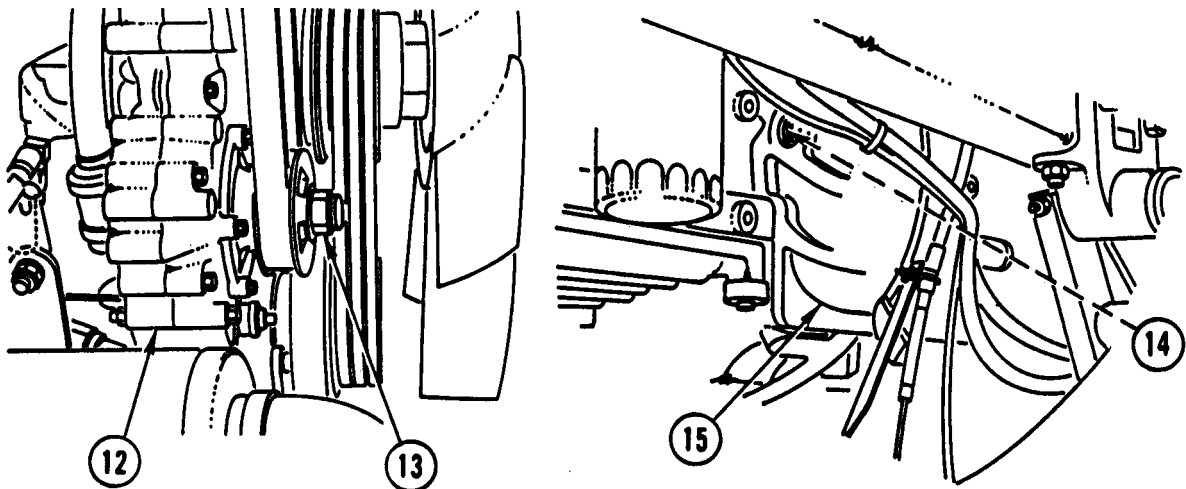

WARNING

Do not place finger in hole of engine flywheel housing while engine is being barred over, To do so could result in serious injury to personnel.

CAUTION

- Step 8 must be followed in barring engine over. Any other method may damage equipment.
- If bolts are dropped in engine flywheel housing, retrieve immediately. Failure to do so will result in damage to equipment.

8. HAVE ASSISTANT BAR ENGINE (12) OVER USING ACCESSORY DRIVE (13), USING INSPECTION MIRROR, LOCATE PLACEMENT AREA FOR BOLT (14). HAVE ASSISTANT STOP BARRING ENGINE OVER. INSTALL BOLT (14) THRU HOLE IN ENGINE BELL HOUSING (15). REPEAT UNTIL 12 BOLTS (14) HAVE BEEN INSTALLED HAND-TIGHT.
9. TIGHTEN 12 BOLTS (14) TO 96-115 LB-FT (131-156 N.m).

TRANSMISSION REPLACEMENT (CONT)

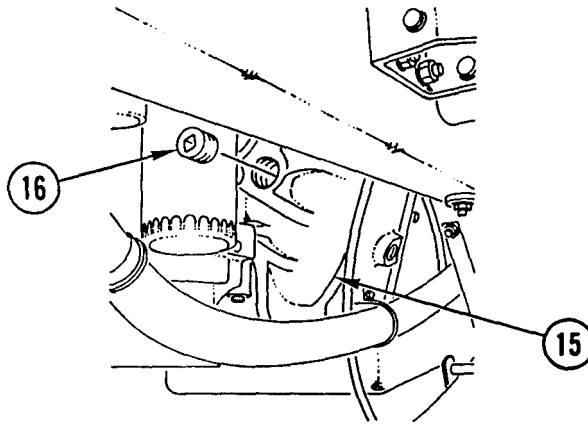

10. INSTALL PLUG (16) IN ENGINE BELL HOUSING (15).

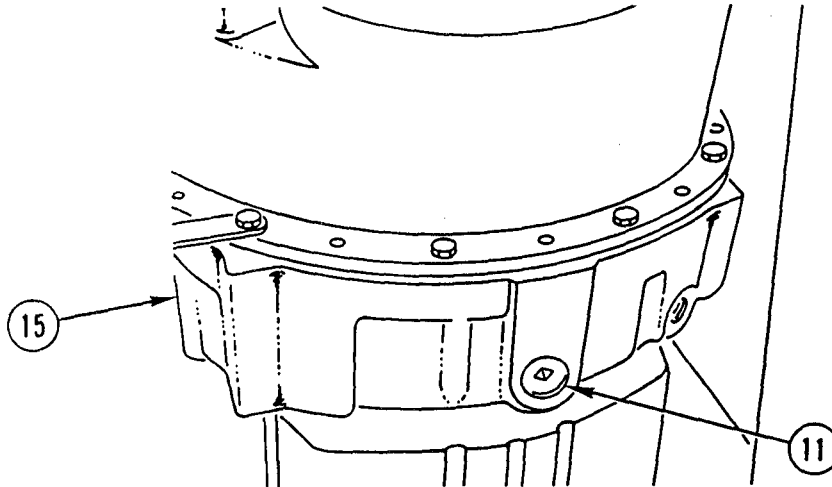

11. INSTALL PLUG (11) IN ENGINE BELL HOUSING (15).

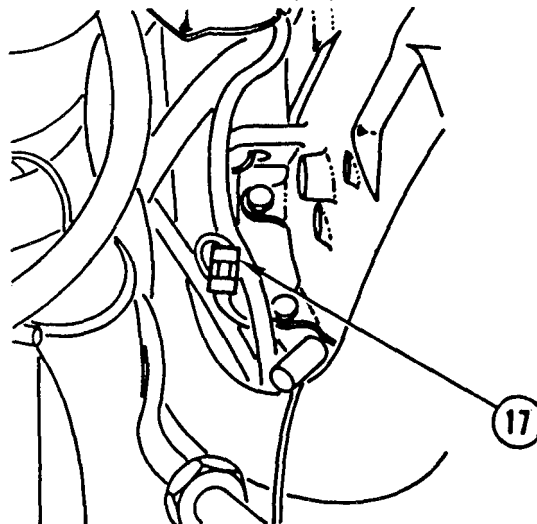

12. CONNECT ELECTRICAL CONNECTOR (17).

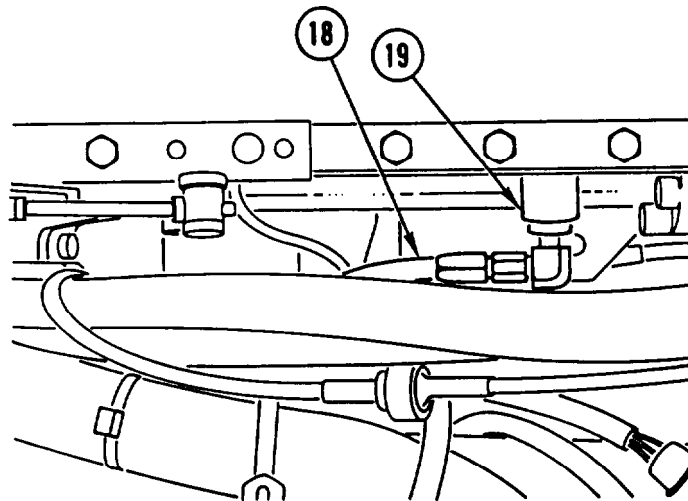

13. CONNECT HOSE (18) TO GOVERNOR (19).

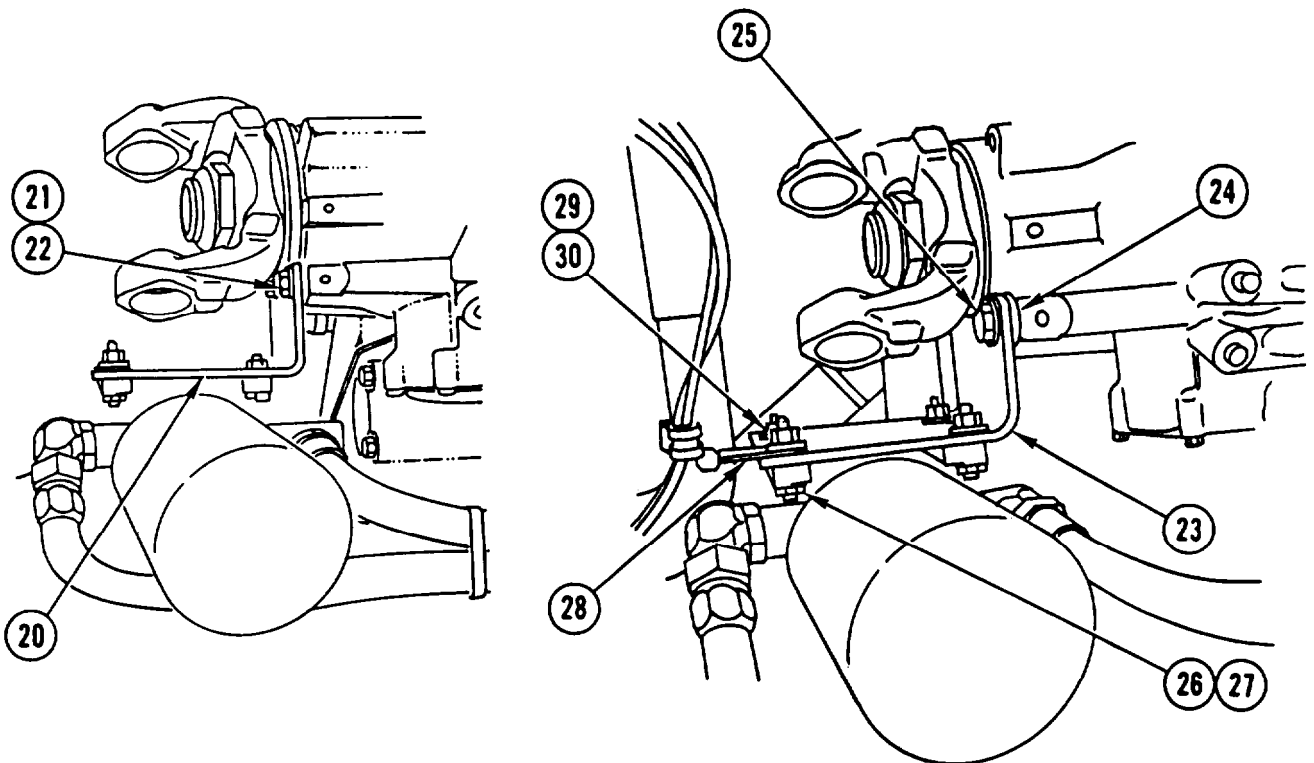

NOTE

Step 14 is for M915A2. Step 15 is for all except M915A2.

- 14. INSTALL OIL FILTER MOUNTING BRACKET (20), TWO WASHERS (21), AND TWO BOLTS (22).
- 15. INSTALL OIL FILTER MOUNTING BRACKET (23), SPACER (24), AND TWO BOLTS (25).
- 16. INSTALL WASHER (26), BOLT (27), BRACKET (28), WASHER (29), AND NUT (30).

TRANSMISSION REPLACEMENT (CONT)

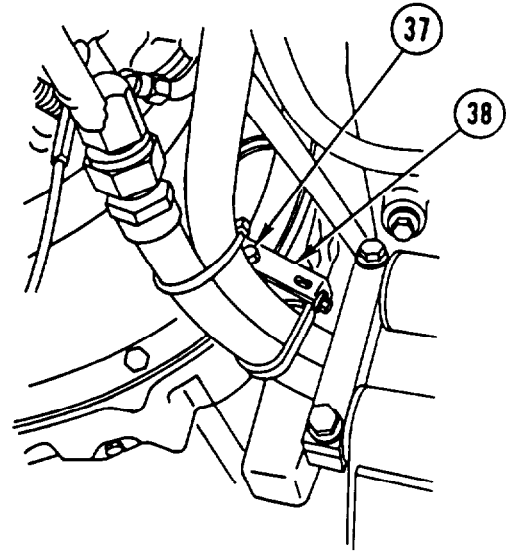
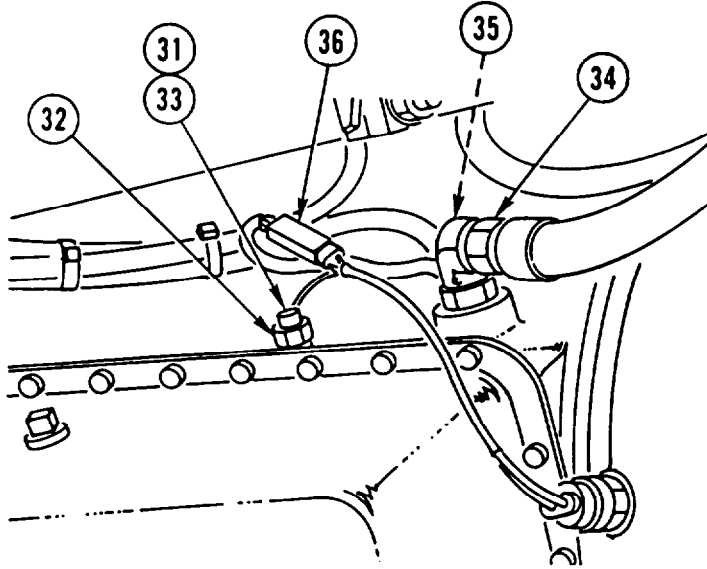

17. CONNECT TWO CABLES (31) TO REVERSE SENDING UNIT (32) AND INSTALL TWO SCREWS (33).
18. CONNECT HYDRAULIC HOSE (34).
19. CONNECT OIL SAMPLE HOSE (35).
20. CONNECT ELECTRICAL CONNECTOR (36).

NOTE

Steps 21 and 22 are for M915A2 only.

21. REMOVE BOLT (37) FROM POSITION NOTED IN REMOVAL STEP 18.
22. POSITION BRACKET (38) AND INSTALL BOLT (37).

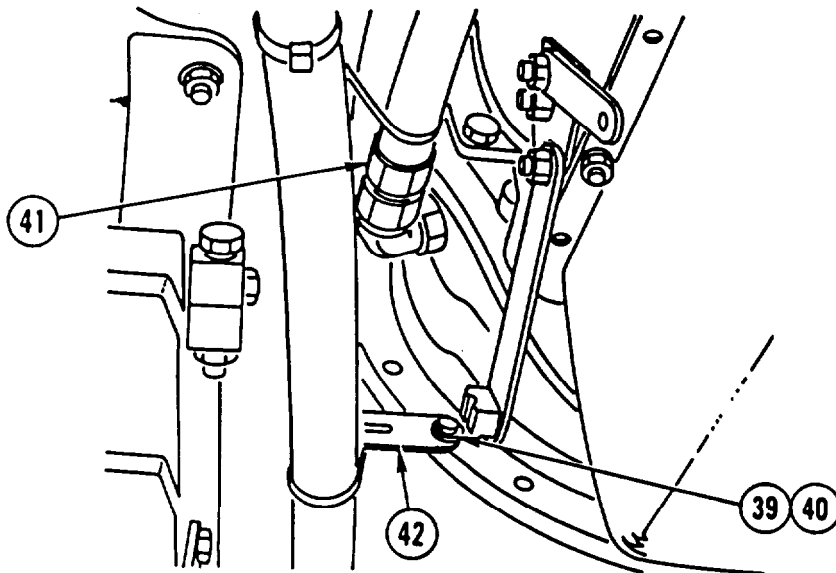

23. REMOVE BOLT (39) AND LOCK WASHER (40) FROM POSITION NOTED IN REMOVAL STEP 16. DISCARD LOCK WASHER.
24. CONNECT HYDRAULIC HOSE (41).
25. POSITION BRACKET (42) AND INSTALL NEW LOCK WASHER (40) AND BOLT (39). TIGHTEN BOLT TO 40 LB-FT (54 N.m).

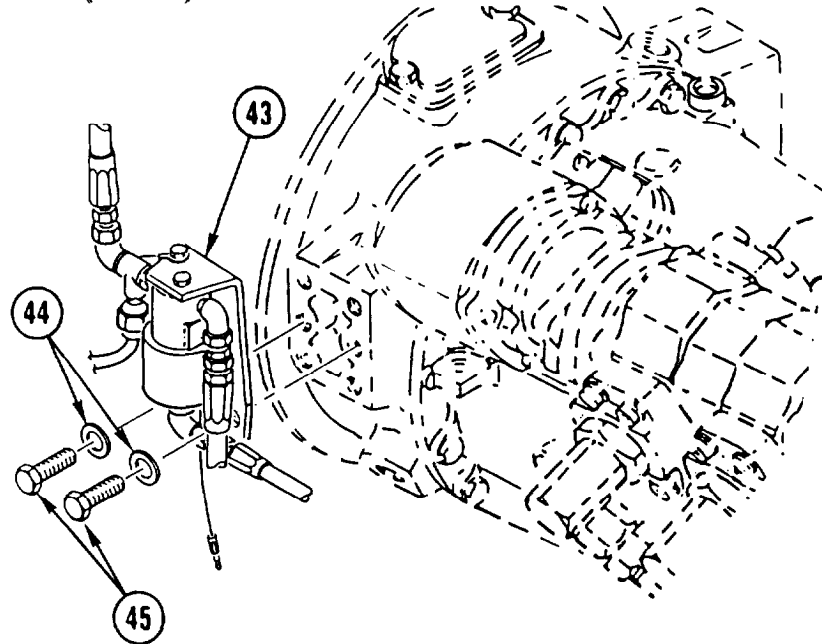

NOTE

Step 26 is for all except M915A2.

26. POSITION BRACKET (43) AND INSTALL TWO WASHERS (44) AND TWO BOLTS (45).

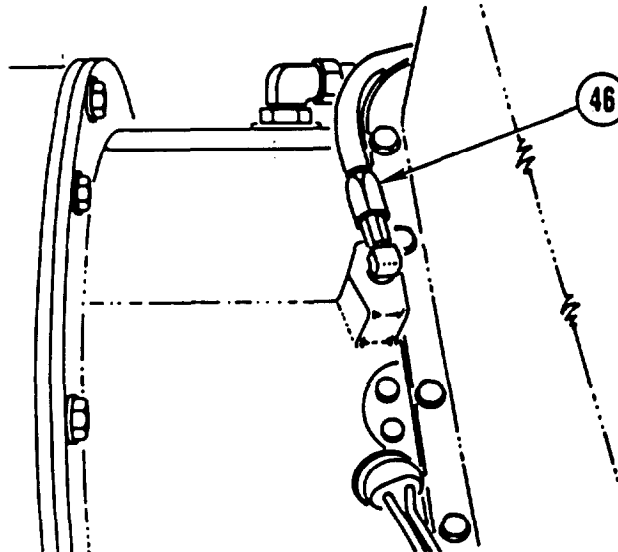

NOTE

Step 27 is for all except M915A2.

27. CONNECT HOSE (46).

TRANSMISSION REPLACEMENT (CONT)

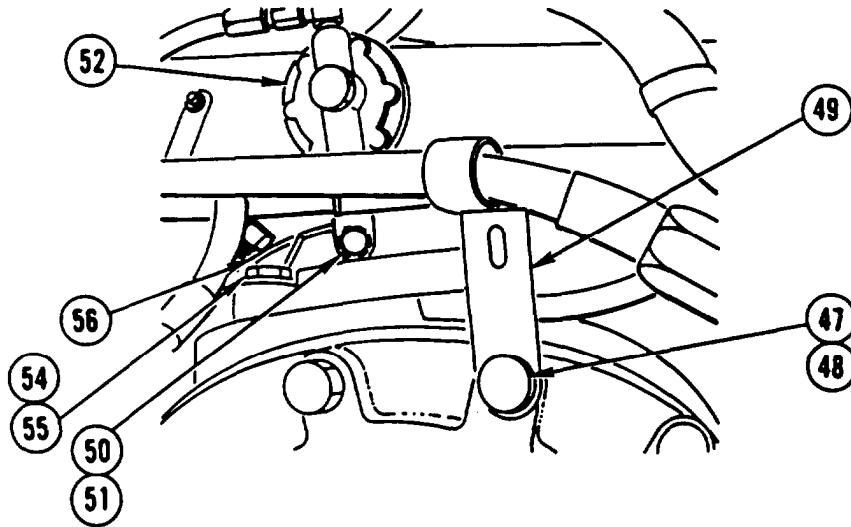

28. REMOVE BOLT (47) AND LOCK WASHER (48) FROM POSITION NOTED IN REMOVAL STEP 12. DISCARD LOCK WASHER.
29. POSITION BRACKET (49) AND INSTALL NEW LOCK WASHER (48) AND BOLT (47). TIGHTEN BOLT TO 40 LB-FT (54 N.m).
30. REMOVE BOLT (50) AND LOCK WASHER (51) FROM POSITION NOTED IN REMOVAL STEP 11. DISCARD LOCK WASHER.
31. POSITION PRESSURE REGULATOR SOLENOID VALVE (52) AND INSTALL NEW LOCK WASHER (51) AND BOLT (50). TIGHTEN BOLT TO 40 LB-FT (54 N.m).
32. CONNECT AIR HOSE (53).
33. REMOVE BOLT (54) AND WASHER (55) AND INSTALL GROUND STRAP (58). INSTALL WASHER (55) AND BOLT (54).

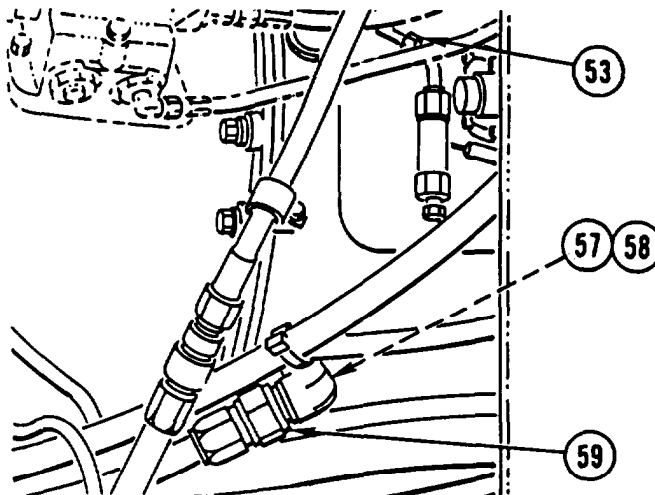

34. CONNECT ELECTRICAL CABLE (57) TO TEMPERATURE SENDING UNIT (58).
35. CONNECT OIL COOLER HOSE (59).

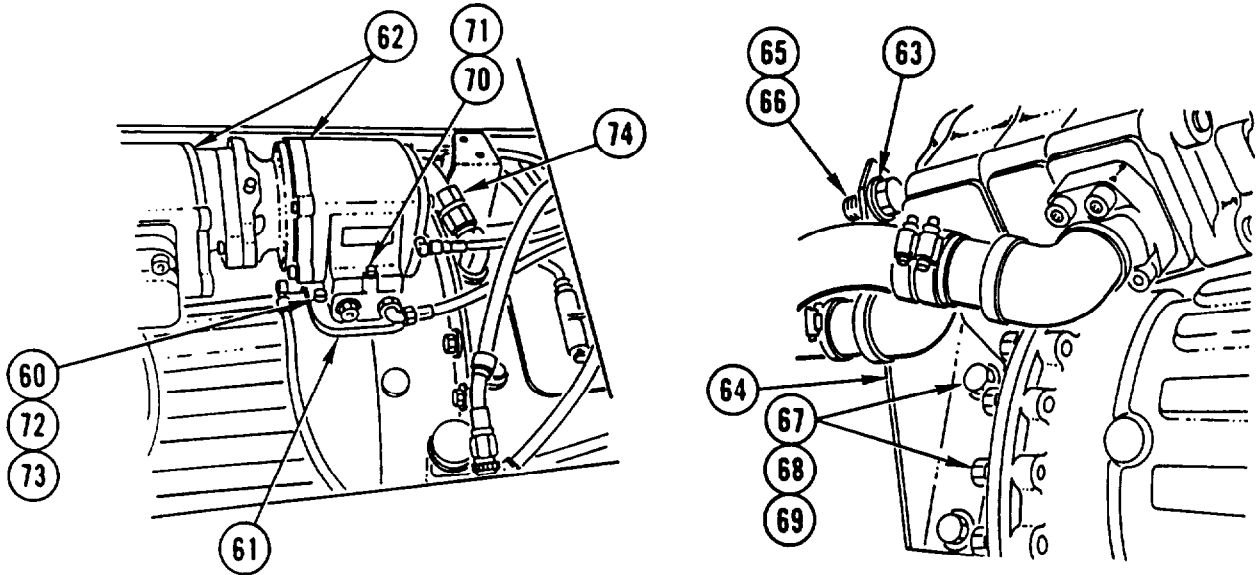

NOTE

Steps 36 thru 40 are for all except M915A2.

36. INSTALL FIVE NEW STUDS (60) AND NEW PTO GASKET (61).
37. POSITION PTO-HYDRAULIC PUMP COMBINATION (62) AND INSTALL THREE WASHERS (63), BRACKET (64), WASHER (65), NEW LOCK NUT (66), TWO WASHERS (67), TWO NEW LOCK WASHERS (68), AND TWO BOLTS (69).
38. INSTALL WASHER (70), CAPSCREW (71), FIVE NEW COPPER GASKETS (72), FIVE NEW NUTS (73), AND HOSE (74).

TRANSMISSION REPLACEMENT (CONT)

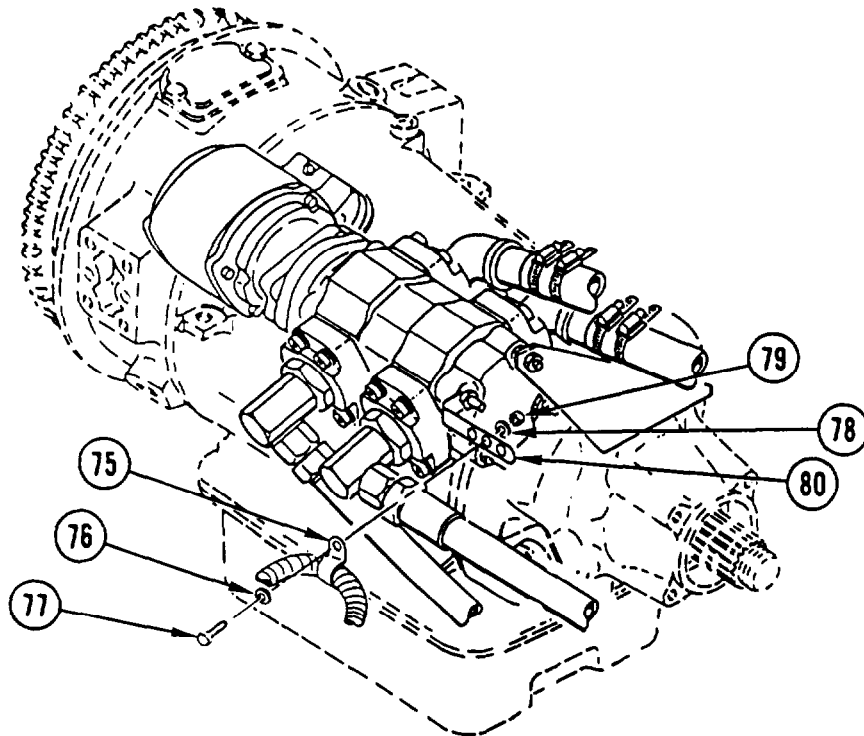

39. INSTALL CLAMP (75), WASHER (76), SCREW (77), WASHER (78), AND NEW LOCK NUT (79) ON BRACKET (80).

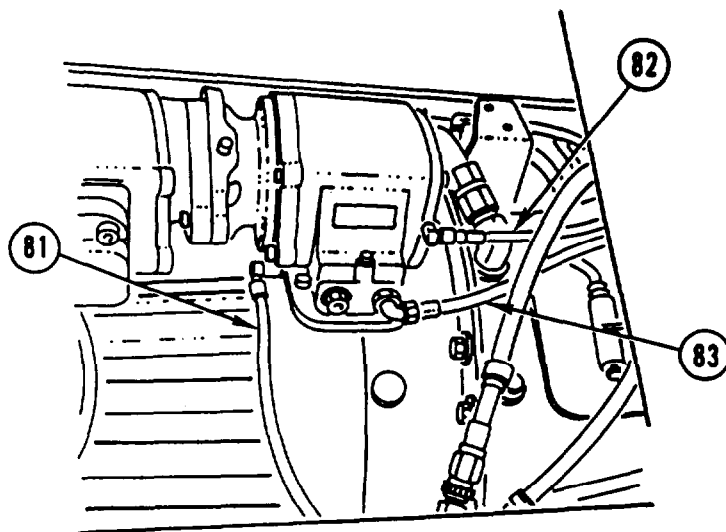

40. CONNECT LUBRICATION HOSE (81) AND TWO AIR HOSES (82 AND 83).

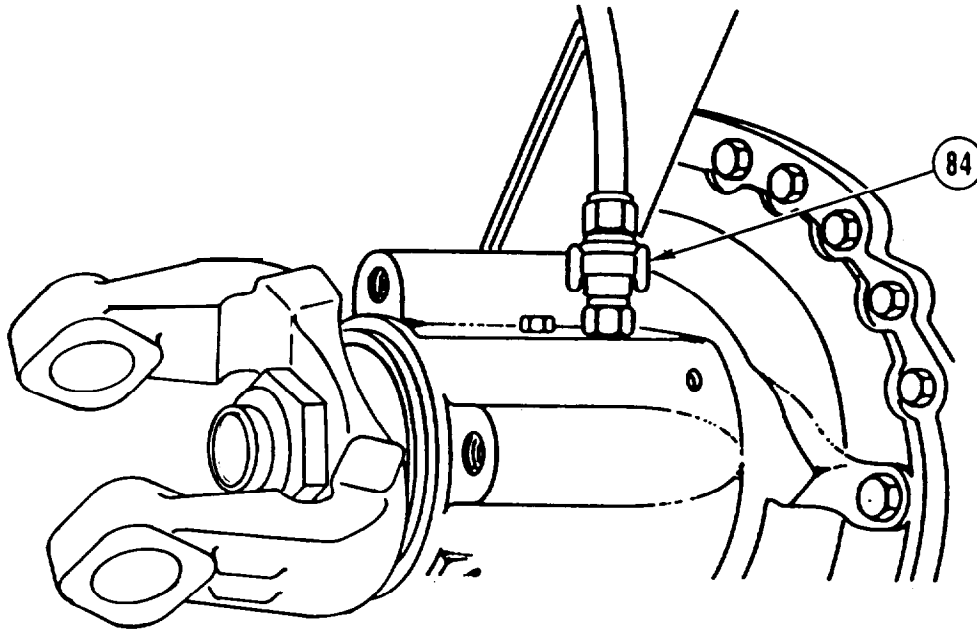

NOTE

Step 41 is for M915A2 only.

41. CONNECT SPEEDOMETER CABLE (84).

NOTE

Follow-on Maintenance:

- Install drivelines (TM 9-2320-363-20).
- Install transmission shift control (TM 9-2320-363-20).
- Adjust transmission shift linkage (TM 9-2320-363-20).
- Install transmission tunnel access cover (TM 9-2320-363-20).
- Install passenger seat (TM 9-2320-363-20).
- Connect batteries (TM 9-2320-363-20).
- Install transmission dipstick tube (TM 9-2320-363-20).
- Install spare tire (TM 9-2320-363-1 0).
- Fill transmission with fluid (TM 9-2320-363-20).

TRANSMISSION OUTPUT YOKE REPLACEMENT AND REPAIR

This task covers: a. Removal b. Cleaning c. Inspection d. Repair e. Installation

INITIAL SETUP

Tools and Special Equipment:

Shop Equipment, SC 4910-95-CL-A31
Tool Kit, SC 5180-90-CL-N05
Output Shaft Seal Installer, J24202-1A
Driver Handle, J24202-4
Yoke Holder Bar, J3453

References:

TM 9-2320-363-20

Equipment Condition:

Reference	Condition	Description
TM 9-2320-363-20	Driveline	Removed

Materials/Parts:

Seal, Oil	P/N 6773311
Nut, Lock	P/N 6771144
Oil, Lubricating	Appendix B, Item 37

REMOVAL

NOTE

Measure torque value after loosening nut. Minimum required to turn nut is 300 lb-in. (33.90 N.m). If value is less, replace nut.

1. USING YOKE HOLDER BAR, REMOVE RETAINER NUT (1) FROM OUTPUT SHAFT (2). DISCARD LOCK NUT.

NOTE

If there are five scribe marks on nut, replace nut.

2. SCRIBE ONE FLAT SIDE OF RETAINER NUT (1).
3. REMOVE OUTPUT YOKE (3) FROM OUTPUT SHAFT (2).
4. REMOVE DUST SHIELD (4) FROM REAR COVER (5).
REMOVE AND DISCARD OIL SEAL (6) FROM REAR COVER (5).

CLEANING

Use general cleaning methods to clean all parts (page 2-30).

INSPECTION

Inspect all parts for wear or damage

REPAIR

Use general repair methods to repair damaged parts (page 2-33).

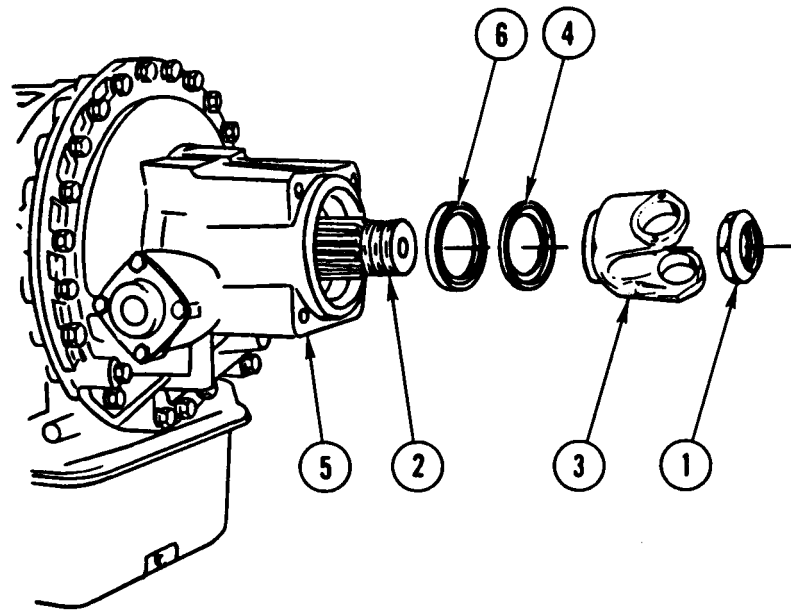

INSTALLATION

1. APPLY COATING OF LUBRICATING OIL TO OUTSIDE AND INSIDE OF NEW OIL SEAL (6).
2. USING OUTPUT SHAFT SEAL INSTALLER, INSTALL OIL SEAL (6) WITH SEAL LIP FACING REAR COVER (5).
3. INSTALL DUST SHIELD (4) IN REAR COVER (5), FLAT SIDE FIRST, SO REAR EDGE OF SHIELD IS FLUSH WITH SURFACE OF REAR COVER.
4. INSTALL OUTPUT YOKE (3) ON OUTPUT SHAFT (2).
5. COAT THREADS OF OUTPUT SHAFT (2) AND RETAINER NUT (1) WITH LUBRICATING OIL.
6. USING YOKE HOLDER BAR, INSTALL NEW RETAINER NUT (1) ON OUTPUT SHAFT (2), TIGHTEN NUT TO 600-800 LB-FT (814-1085 N.m).

NOTE

Follow-on Maintenance:
Install driveline (TM 9-2320-363-20).

INTERNAL FILTER ELEMENT REPLACEMENT

This task covers: a. Removal b. Cleaning c. inspection d. Installation

INITIAL SETUP

Tools and Special Equipment:

Shop Equipment, SC 4910-95-CL-A31
Tool Kit, SC 5180-90-CL-N05

References:

TM 9-2320-363-20

Materials/Parts:

Packing	P/N 23013114
Oil, Lubricating	Appendix B, Item 37

Equipment Condition:

Reference	Condition Description
TM 9-2320-363-20	Transmission Oil Pan Removed

REMOVAL

1. REMOVE SCREW (1), WASHER (2), AND FILTER ELEMENT (3) FROM TRANSMISSION (4).
2. REMOVE SPACER (5).
3. REMOVE AND DISCARD PACKING (6) FROM FILTER ELEMENT (3).
4. IF FILTER ELEMENT (3) IS DAMAGED OR CLOGGED, REPLACE WITH NEW ELEMENT.

CLEANING

Use general cleaning methods to clean all parts (page 2-30).

INSPECTION

Inspect all parts for wear or damage.

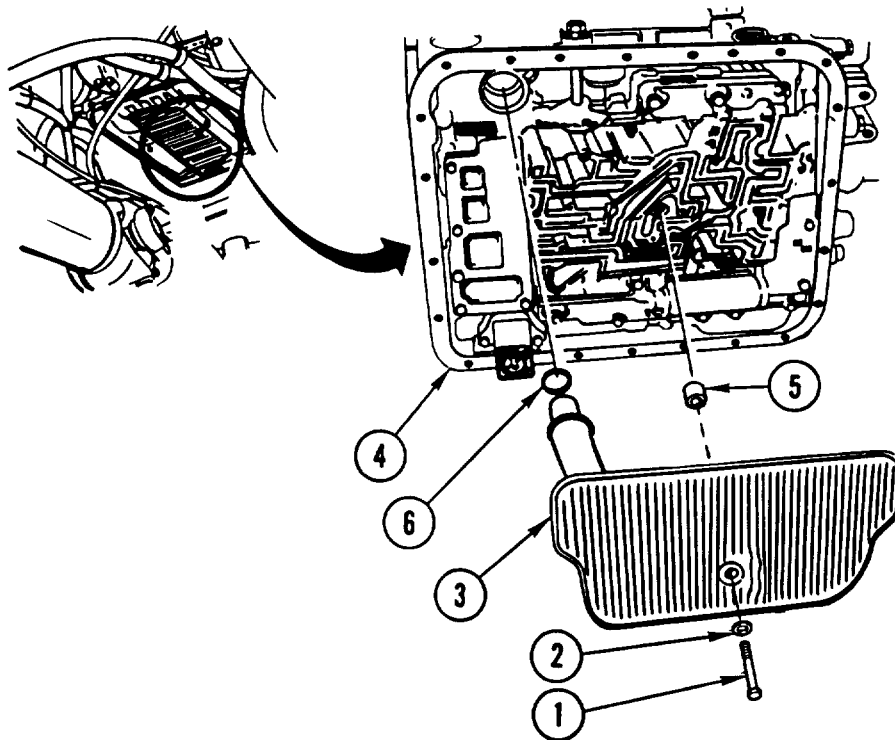

INSTALLATION

1. COAT NEW PACKING (6) WITH LUBRICATING OIL AND INSTALL PACKING (6) ON FILTER ELEMENT (3).
2. INSTALL SCREW (1) AND WASHER (2) THRU FILTER ELEMENT (3) AND SPACER (5).
3. INSTALL FILTER ELEMENT (3) IN TRANSMISSION (4),
4. TIGHTEN SCREW (1) TO 10-15 LB-FT (14-20 N.m).

NOTE

Follow-on Maintenance:
Install transmission oil pan (TM 9-2320-363-20).

GOVERNOR SERVICE AND REPLACEMENT

This task covers: a. Removal b. Installation

INITIAL SETUP

Tools and Special Equipment:

Shop Equipment, SC 4910-95-CL-A31
Tool Kit, SC 5180-90-CL-N05

Materials/Parts:

Gasket P/N 23011670

REMOVAL

NOTE

Have suitable container available to catch fluid when cover is removed.

1. REMOVE FOUR SCREWS (1), COVER (2), AND GASKET (3) FROM TRANSMISSION (4). DISCARD GASKET.
2. TURN GOVERNOR (5) CLOCKWISE AND REMOVE FROM TRANSMISSION (4).

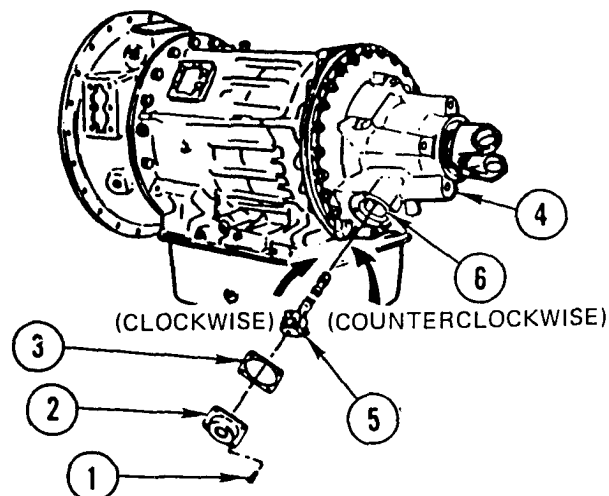

INSTALLATION

1. TURN GOVERNOR (5) COUNTERCLOCKWISE IN PORT (6).
2. ALINE HOLES IN NEW GASKET (3) AND COVER (2) WITH HOLES IN PORT (6).
3. INSTALL FOUR SCREWS (1), COVER (2), AND NEW GASKET (3) IN TRANSMISSION (4). TIGHTEN SCREWS TO 10-15 LB-FT (14-20 N.m).

MODULATOR VALVE REPLACEMENT

This task covers: a. Removal b. Installation

INITIAL SETUP

Tools and Special Equipment:

Shop Equipment, SC4910-95-CL-A31
 Tool Kit, SC 5180-90-CL-N05

Materials/Parts:

Packing P/N 118233

References:

TM 9-2320-363-20

Equipment Condition:

Reference	Condition Description
TM 9-2320-363-20	Air System Drained

REMOVAL

1. DISCONNECT HOSE (1) FROM MODULATOR VALVE (2).
2. REMOVE SCREW (3), BRACKET (4), MODULATOR VALVE (2), AND PACKING (5). DISCARD PACKING.

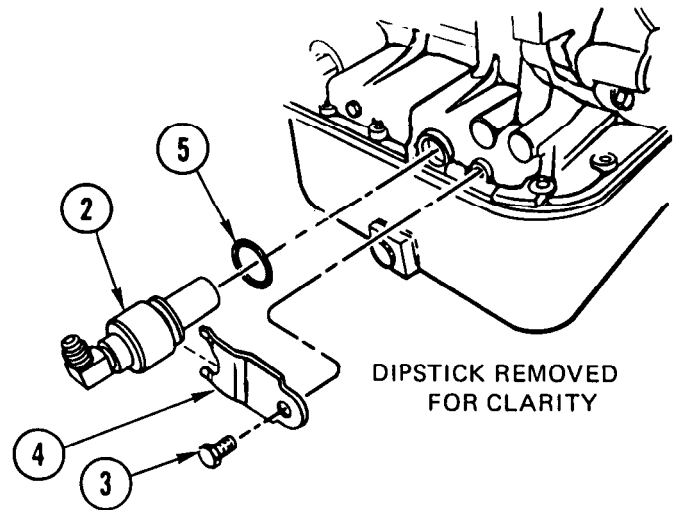
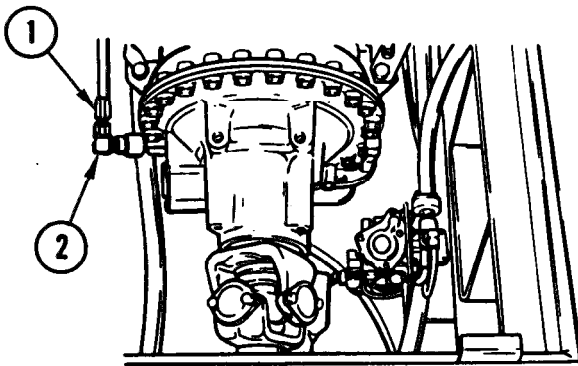

INSTALLATION

1. INSTALL NEW PACKING (5), MODULATOR VALVE (2), BRACKET (4), AND SCREW (3).
2. TIGHTEN SCREW (3) TO 8-10 LB-FT (11-14 N.m).
3. CONNECT HOSE (1) TO MODULATOR VALVE (2).

LOCKUP CUTOFF CONTROL VALVE REPLACEMENT

This task covers: a. Removal b. Installation

INITIAL SETUP

Tools and Special Equipment:

Shop Equipment, SC 4910-95-CL-A31
Tool Kit, SC 5180-90-CL-N05

Equipment Condition:

Reference

Page 3-258

Condition Description

Internal Filler
Element Removed

REMOVAL

REMOVE EIGHT SCREWS (1) AND VALVE (2) FROM TRANSMISSION (3).

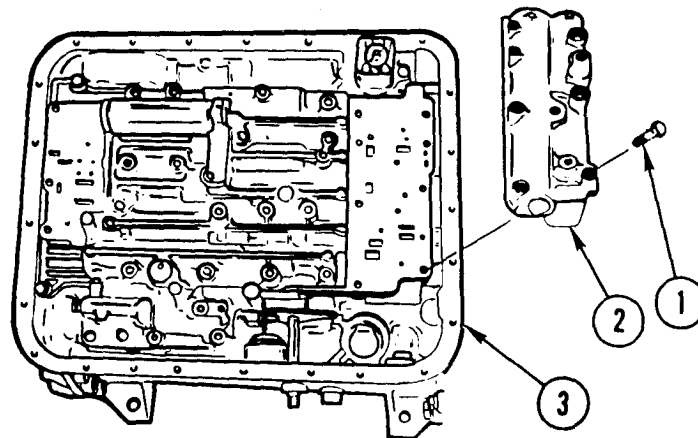

INSTALLATION

INSTALL VALVE (2) AND EIGHT SCREWS (1) IN TRANSMISSION (3). TIGHTEN SCREWS TO 108-132 LB-IN. (12-15 N.m).

NOTE

Follow-on Maintenance:
Install internal filter element (page 3-258).

TRANSFER CASE REPLACEMENT

This task covers: a. Removal b. Cleaning c. Inspection d. Installation

INITIAL SETUP

Applicable Configuration:

All except M915A2

Tools and Special Equipment:

Shop Equipment, SC 4910-95-CL-A31
 Tool Kit, SC 5180-90-CL-N05

Materials/Parts:

Pin, Cotter Clevis P/N 49044-2

Washer, Lock (2)

References:

TM 9-2320-363-10
 TM 9-2320-363-20

Equipment Description:

Reference	Condition Description
TM 9-2320-363-10	Transfer Case Shift Lever Set to Neutral
TM 9-2320-363-10	Spare Tire Removed
TM 9-2320-363-20	Transfer Case to Front Axle, Transmission to Transfer Case, and Transfer Case to Forward-Rear Axle Drivelines Removed

Equipment Description (Cont):

Reference	Condition Description
TM 9-2320-363-10	Wheels Chocked
TM 9-2320-363-20	Air System Drained
TM 9-2320-363-20	Batteries Disconnected
TM 9-2320-363-20	Transfer Case Oil Drained

General Safety Instructions:

WARNING

Transfer case weighs 850 lb (386 kg). Support transfer case with suitable floor jack during removal or installation to prevent possible injury to personnel.

TRANSFER CASE REPLACEMENT (CONT)

REMOVAL

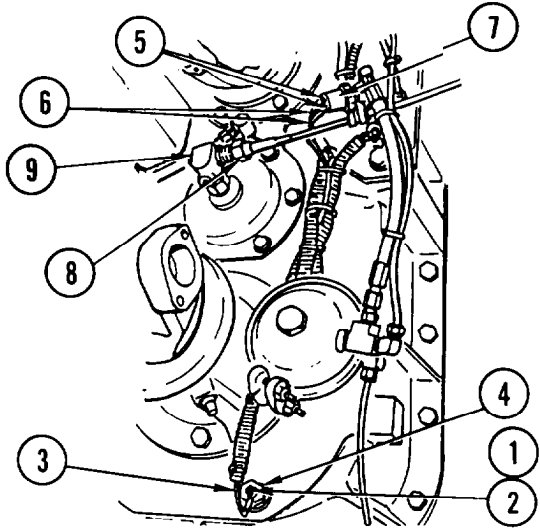

M916A1

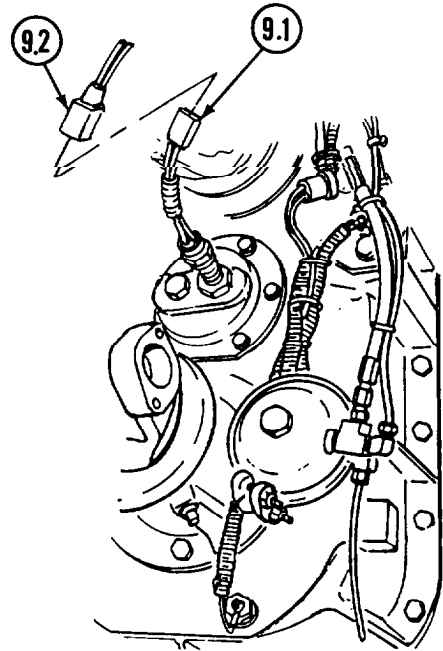

M916A2

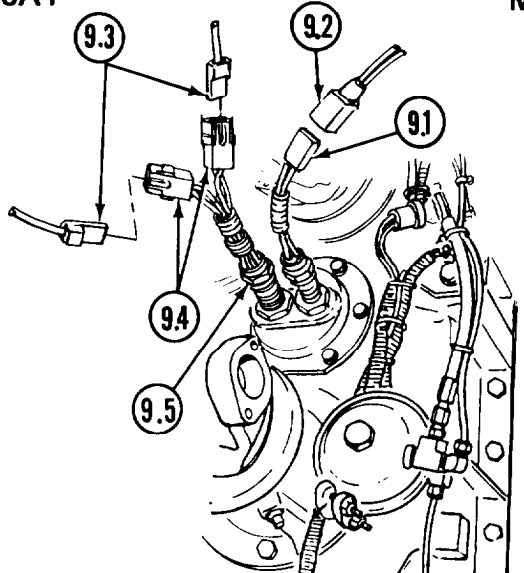

M917A1 and M917A1w/MCS

NOTE

Tag all electrical cables prior to removal to aid in installation.

1. REMOVE NUT (1) AND TWO WASHERS (2) AND DISCONNECT CABLE (3) FROM TEMPERATURE SENSOR (4).
2. REMOVE TWO SCREWS (5) AND DISCONNECT TWO CABLES (6) FROM ALL WHEEL DRIVE SENDING UNIT (7).
3. ON M916A1, DISCONNECT SPEEDOMETER CABLE CONNECTOR (8) FROM DRIVE FITTING (9). ON ALL EXCEPT M916A1, DISCONNECT SPEEDOMETER SENDING UNIT CONNECTOR (9.1) FROM WIRING HARNESS CONNECTOR (9.2).

4. ON M917A1 AND M917A1 W/MCS, DISCONNECT CTIS WIRING HARNESS CONNECTORS (9.3) FROM SPEED SENSOR CONNECTORS (9.4). IF A NEW TRANSFER CASE IS TO BE INSTALLED, REMOVE SPEED SENSOR (9.5) AND INSTALL ON NEW TRANSFER CASE.
5. REMOVE SEVEN FASTENERS (10), CLAMP (11), AND DUST COVER (12).

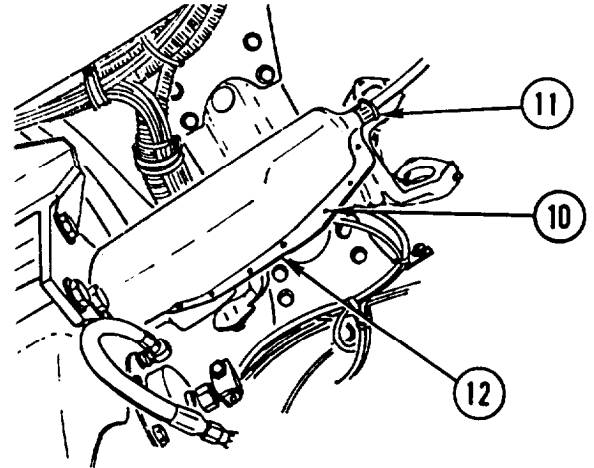

6. REMOVE COTTER PIN (13) AND PIN (14) AND DISCONNECT CLEVIS (15). DISCARD COTTER PIN.
7. REMOVE TWO CAPSCREWS (16) AND TWO LOCK WASHERS (17) AND SET BRACKET (18) ASIDE. DISCARD LOCK WASHERS.

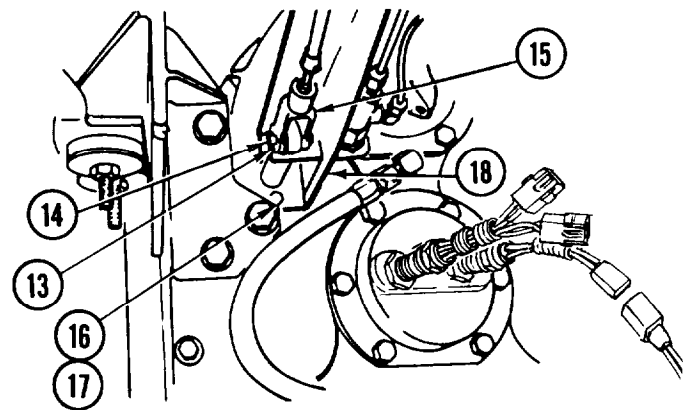

NOTE

Tag air lines prior to removal to aid in installation.

8. DISCONNECT TWO AIR LINES (19) FROM SHIFT CHAMBER (20).
9. REMOVE BOLT (21) AND WASHER (22) AND SET BRACKET (23) ASIDE.

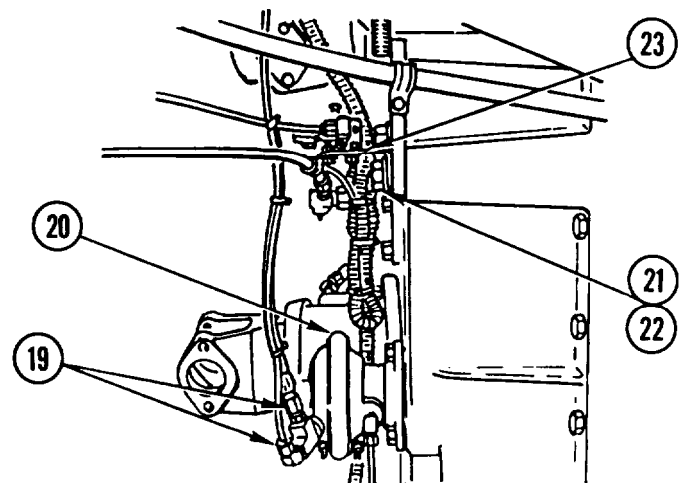

TRANSFER CASE REPLACEMENT (CONT)

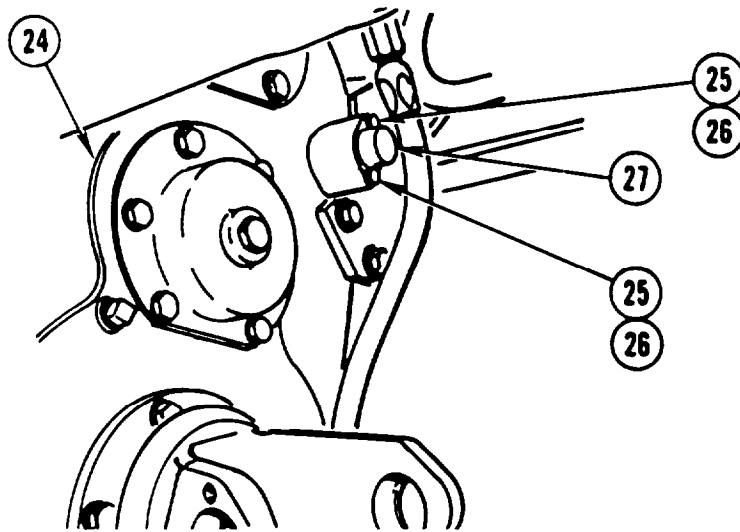

WARNING

Transfer case weighs 850 lb (386 kg). Support transfer case with suitable floor jack during removal to prevent possible injury to personnel.

10. ATTACH SUITABLE HOIST TO TRANSFER CASE (24) AND REMOVE TWO CAPSCREWS (25) TWO WASHERS (26), AND SHAFT COVER (27).

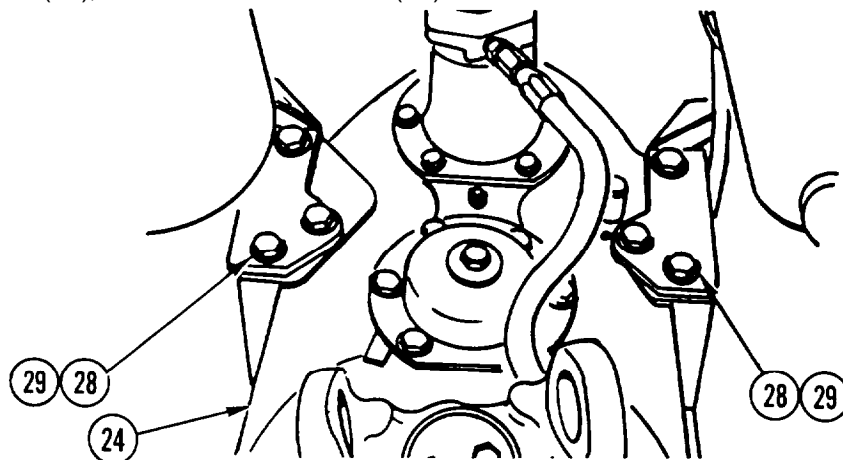

WARNING

Transfer case weighs 850 lb (386 kg). Support transfer case with suitable floor jack during removal to prevent possible injury to personnel.

11. REMOVE 12 CAPSCREWS (28) AND 12 WASHERS (29) AND LOWER TRANSFER CASE (24) TO GROUND.

CLEANING

Use general cleaning methods to clean all parts (page 2-30).

INSPECTION

Inspect all parts for wear or damage

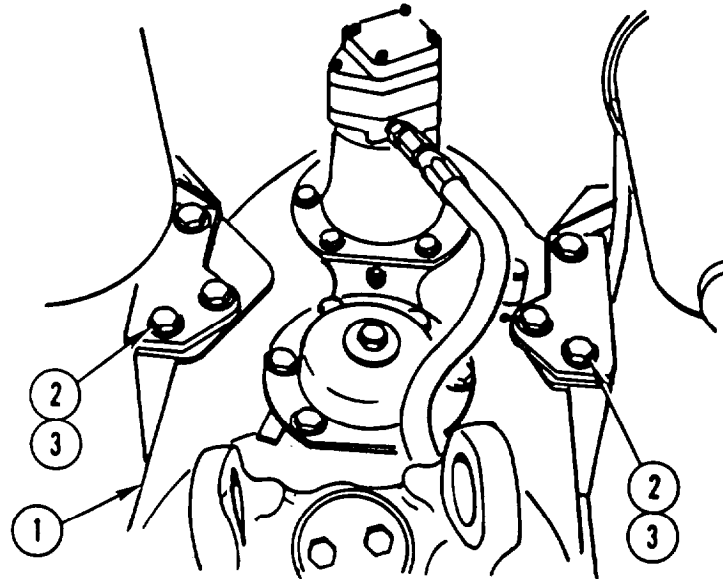
INSTALLATION**WARNING**

Transfer case weighs 850 lb (386 kg). Support transfer case with suitable floor jack during removal to prevent possible injury to personnel.

1. ATTACH SUITABLE FLOOR JACK TO TRANSFER CASE (1) AND RAISE TRANSFER CASE (1) INTO POSITION.
2. INSTALL 12 WASHERS (2) AND 12 CAPSCREWS (3).

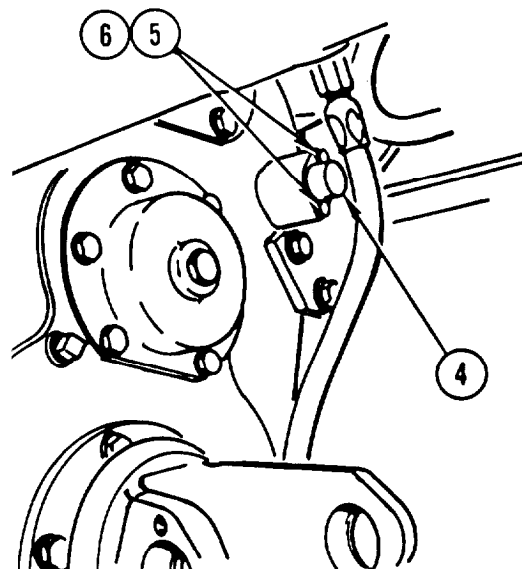

3. INSTALL SHAFT COVER (4) TWO WASHERS (5) AND TWO CAPSCREWS (6).

TRANSFER CASE REPLACEMENT (CONT)

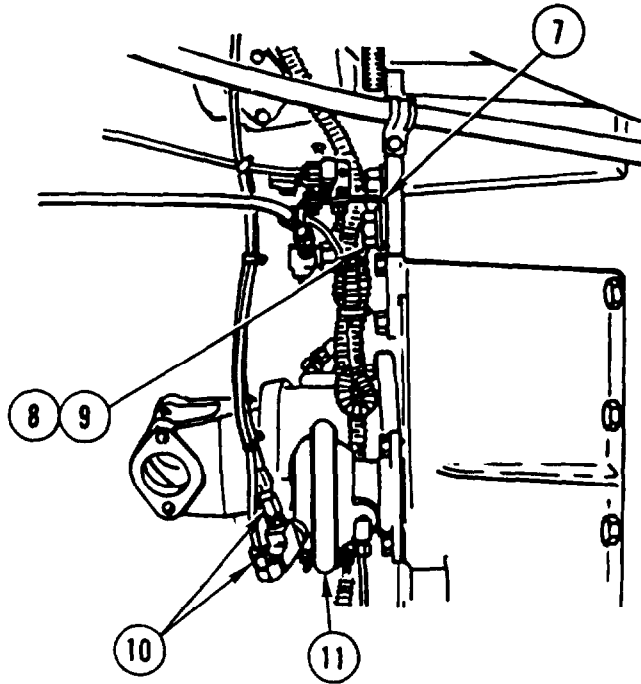

4. POSITION BRACKET (7) AND INSTALL WASHER (8) AND BOLT (9).
5. CONNECT TWO AIR LINES (10) TO SHIFT CHAMBER (11).
6. POSITION BRACKET (12) AND INSTALL TWO NEW LOCK WASHERS (13) AND TWO CAPSCREWS (14).
7. CONNECT CLEVIS (15) AND INSTALL PIN (16) AND NEW COTTER PIN (17).

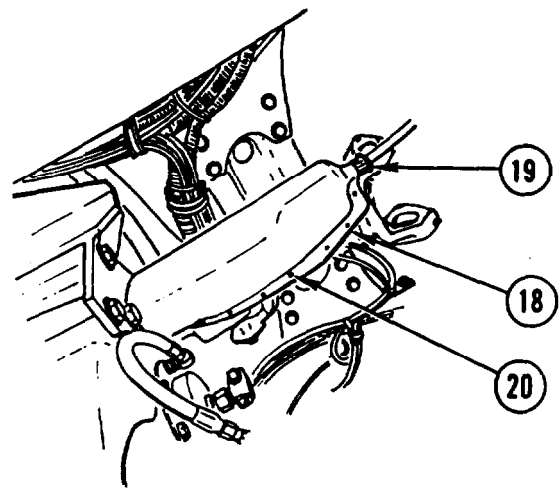
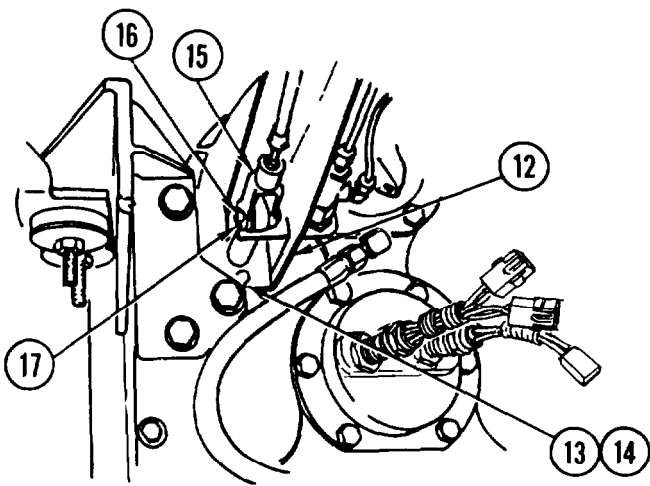

8. INSTALL DUST COVER (18), CLAMP (19) AND SEVEN FASTENERS (20).

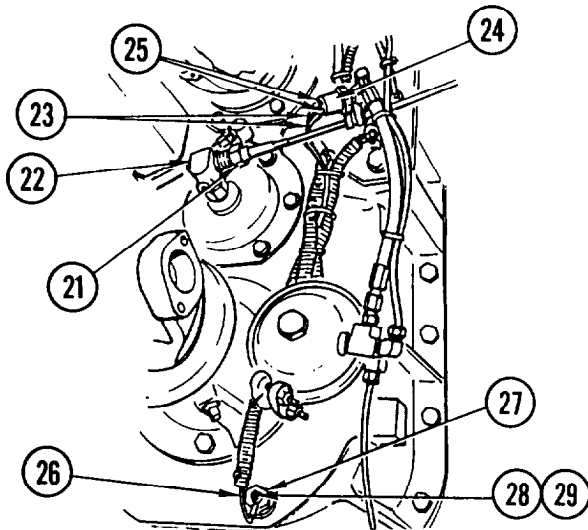

M916A1

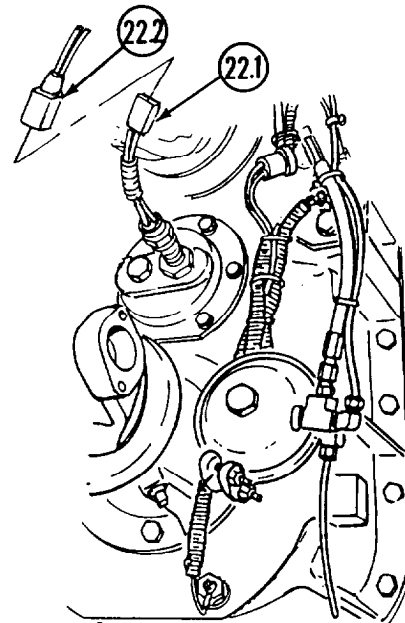

M916A2

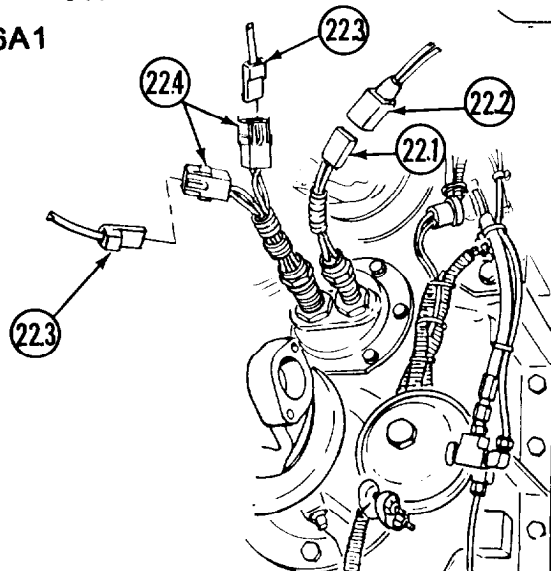

M917A1 AND M917A1 w/MCS

9. ON M916A1, CONNECT SPEEDOMETER CABLE CONNECTOR (21) TO DRIVE FITTING (22). ON ALL EXCEPT M916A1, CONNECT SPEEDOMETER SENDING UNIT CONNECTOR (22.1) TO WIRING HARNESS CONNECTOR (22.2).
10. ON M917A1 AND M917A1 W/MCS, CONNECT CTIS WIRING HARNESS CONNECTORS (22.3) TO SPEED SENSOR CONNECTORS (22.4).
11. CONNECT TWO CABLES (23) TO ALL WHEEL DRIVE SENDING UNIT (24) AND INSTALL TWO SCREWS (25).
12. CONNECT CABLE (26) TO TEMPERATURE SENSOR (27) AND INSTALL TWO WASHERS (28) AND NUT (29).

NOTE

Follow-on Maintenance:

- Fill transfer case with oil (TM 9-2320-363-20).
- Install drivelines (TM 9-2320-363-20).
- Install spare tire (TM 9-2320-363-10).
- Connect batteries (TM 9-2320-363-20).

TRANSFER CASE MOUNTS REPLACEMENT

This task covers: a. Removal b. Cleaning c. Inspection d. Installation

INITIAL SETUP

Applicable Configuration:

All except M915A2

Tools and Special Equipment:

Tool Kit, SC 5180-90-CL-N05

Personnel Required: (2)

Materials/Parts:

Loctite 510

Appendix B, Item 34.1

Equipment Description:

Reference

Condition Description

Page 3-263

Transfer Case Removed

REMOVAL

NOTE

Perform steps 1 thru 4 to remove transfer case mount from left frame rail.

1. REMOVE TWO NUTS (1), FOUR WASHERS (2) TWO CAPSCREWS (3) AND TWO WASHERS (4) FROM LOWER BRACKET (5).
2. REMOVE LOWER BRACKET (5) AND FOUR RUBBER MOUNTS (6) FROM UPPER BRACKET (7).

NOTE

- Perform step 3 for M916A1 and M916A2.
 - Note position of screws for installation.
3. REMOVE SIX NUTS (8) TEN WASHERS (9) TWO FLAT HEAD SCREWS (10), FOUR CAPSCREWS (11) AND UPPER BRACKET (7) FROM LEFT FRAME RAIL (12).

NOTE

- Perform step 4 for M917A1 and M917A1 w/MCS.
 - Note position of capscrews for installation.
4. REMOVE SEVEN NUTS (8) AND CAPSCREWS (11), 14 WASHERS (9) AND UPPER BRACKET (7) FROM LEFT FRAME RAIL (12).

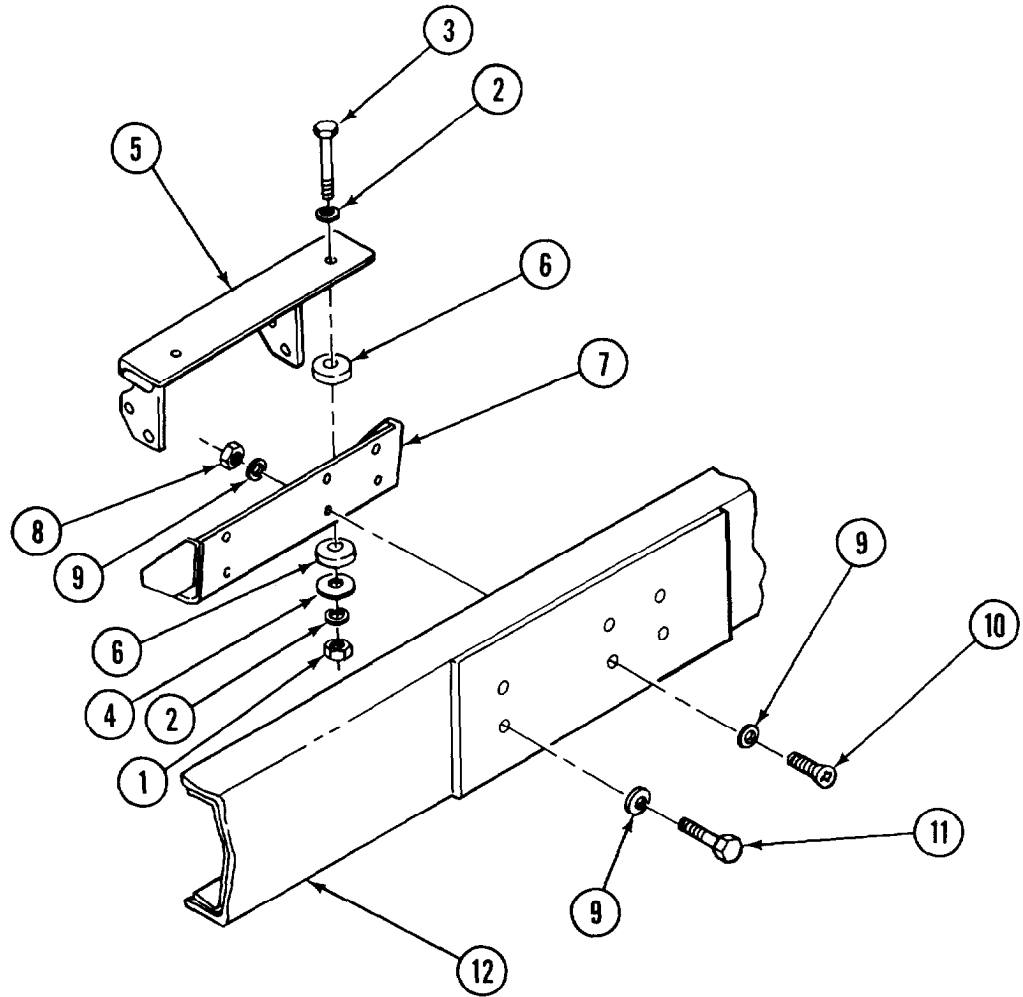

TRANSFER CASE MOUNTS REPLACEMENT (CONT)

NOTE

Perform steps 5 thru 7 to remove transfer case mount from right frame rail.

5. REMOVE TWO NUTS (13), FOUR WASHERS (14), TWO CAPSCREWS (15), AND TWO WASHERS (16) FROM LOWER BRACKET (17).
6. REMOVE LOWER BRACKET (17) AND FOUR RUBBER MOUNTS (18) FROM UPPER BRACKET (19).

NOTE

Note position of capscrews for installation.

7. REMOVE FOUR NUTS (20), FOUR CAPSCREWS (21), EIGHT WASHERS (22), AND UPPER BRACKET (19) FROM RIGHT FRAME RAIL (23).

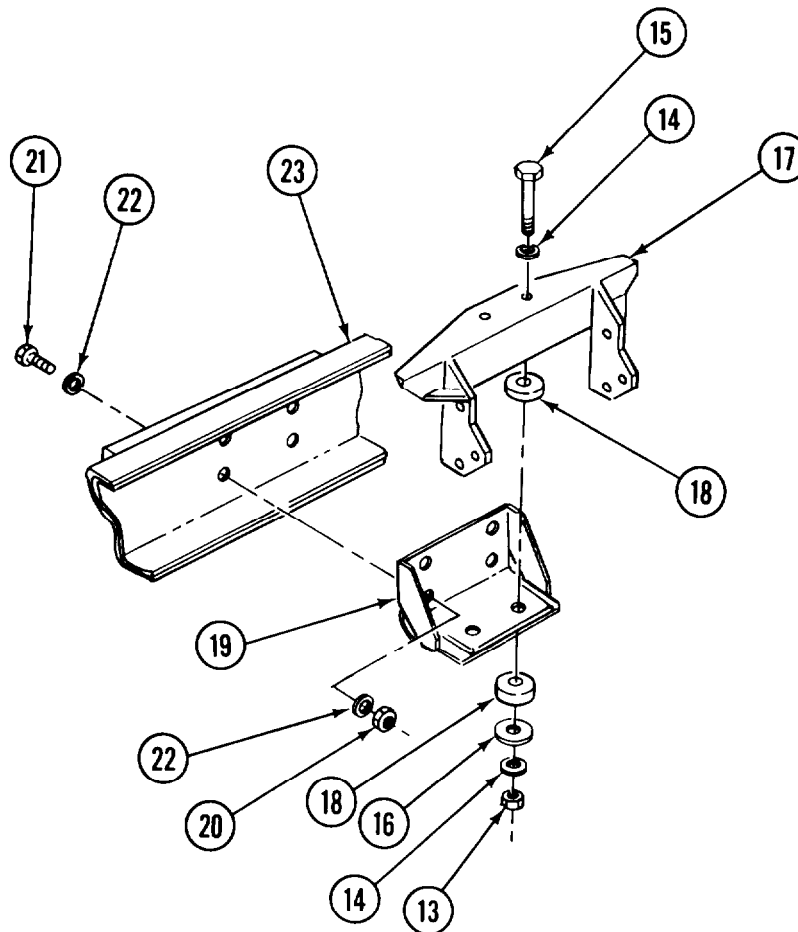

CLEANING

Use general cleaning methods to clean all parts (page 2-30)

INSPECTION

Inspect all parts for wear or damage.

INSTALLATION

NOTE

- Coat threads of all capscrews with loctite 510 at installation.
 - Perform steps 1 thru 3 to install transfer case mount to right frame rail.
1. INSTALL UPPER BRACKET (1) TO RIGHT FRAME RAIL (2) WITH EIGHT WASHERS (3) FOUR CAPSCREWS (4) AND FOUR NUTS (5).
 2. POSITION FOUR RUBBER MOUNTS (6) AND LOWER BRACKET (7) TO UPPER BRACKET (1).
 3. INSTALL FOUR WASHERS (8) TWO CAPSCREWS (9) TWO WASHERS (10) AND TWO NUTS (11).

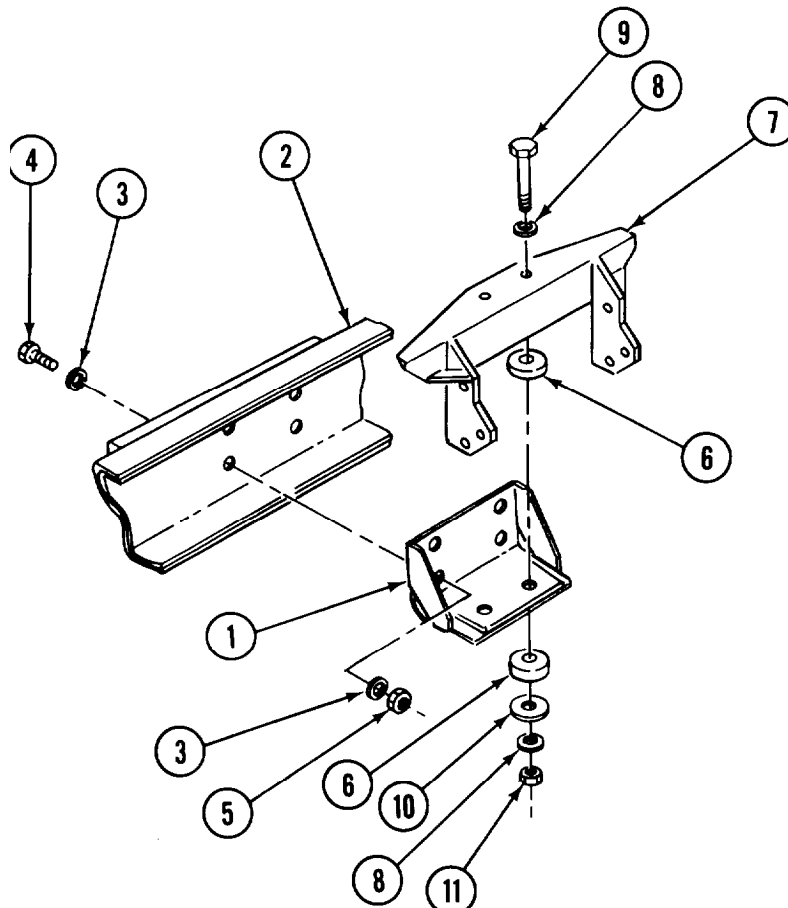

TRANSFER CASE MOUNTS REPLACEMENT (CONT)

NOTE

- Perform steps 4 thru 7 to install transfer case mount to left frame rail.
- Perform step 4 for M917A1 and M917A1 w/MCS.

4. INSTALL UPPER BRACKET (12) TO LEFT FRAME RAIL (13) WITH 14 WASHERS (14) AND SEVEN CAPSCREWS (15) AND NUTS (16).

NOTE

Perform step 5 for M916A1 and M916A2.

5. INSTALL UPPER BRACKET (12) TO LEFT FRAME RAIL (13) WITH TEN WASHERS (14) FOUR CAPSCREWS (15), TWO FLAT HEAD SCREWS (17), AND SIX NUTS (16).
6. POSITION FOUR RUBBER MOUNTS (18), AND LOWER BRACKET (19) TO UPPER BRACKET (12).
7. INSTALL TWO WASHERS (20), TWO CAPSCREWS (21), FOUR WASHERS (22), AND TWO NUTS (23).

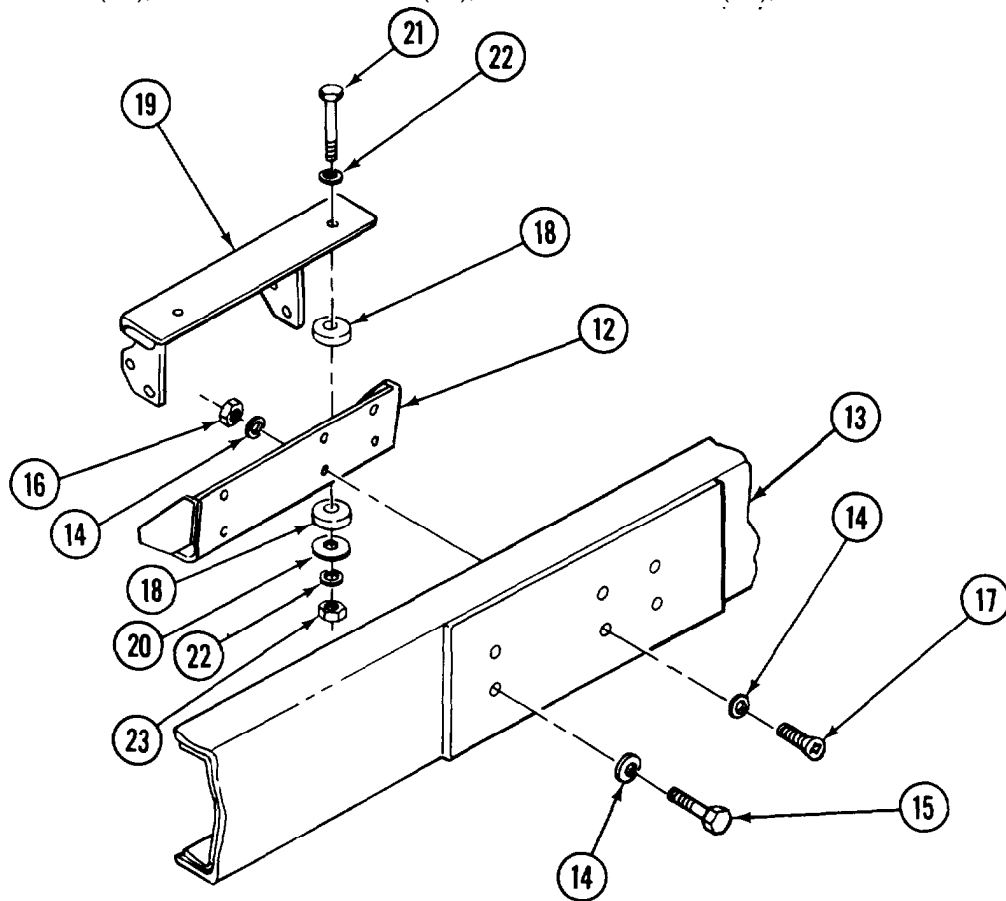

NOTE

Follow-on Maintenance:

Install transfer case (page 3-263).

THIS PAGE INTENTIONALLY LEFT BLANK

AIR SHIFT CHAMBER REPLACEMENT

This task covers: a. Removal b. Cleaning c. Inspection d. Installation

INITIAL SETUP

Applicable Configuration:

All except M915A2

Tools and Special Equipment:

Tool Kit, SC 5180-90-CL-N05

Materials/Parts:

Seal P/N 234322

Packing P/N 1PS43

Nut, Lock

Gasket P/N 13308 FX

Washer, Lock (2)

Adhesive-Sealant, Silicone Appendix B, Item 3

Compound, Pipe Sealing Appendix B, Item 15

References:

TM 9-2320-363-20

Equipment Condition:

Reference	Condition	Description
TM 9-2320-363-20	Air System	Drained
TM 9-2320-363-20	Transfer Case	Oil Drained

General Safety Instructions:

WARNING

Adhesives, solvents, and sealing compounds can burn easily, can give off harmful vapors, and are harmful to skin and clothing. To avoid injury or death, keep away from open fire and use in well-ventilated area. If adhesive, solvent, or sealing compound gets on skin or clothing, wash immediately with soap and water.

REMOVAL

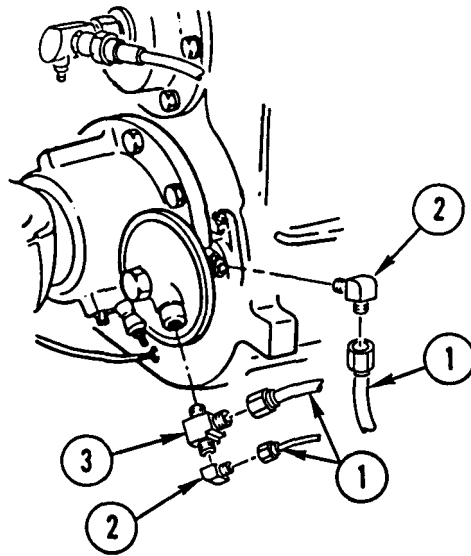

1. REMOVE THREE AIR HOSES (1), TWO ELBOWS (2), AND TEE (3).

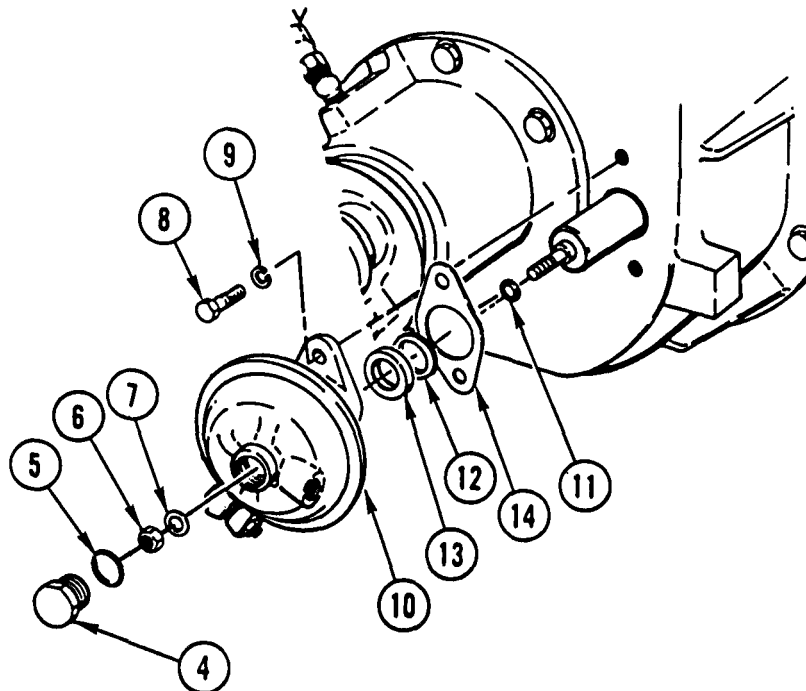

2. REMOVE PLUG (4), PACKING (5), LOCK NUT (6), AND WASHER (7), DISCARD PACKING AND LOCK NUT.
3. REMOVE TWO SCREWS (8), TWO LOCK WASHERS (9), AIR SHIFT CHAMBER (10), WASHER (11), PILOT RING (12), SEAL (13), AND GASKET (14). DISCARD LOCK WASHERS, SEAL, AND GASKET.

AIR SHIFT CHAMBER REPLACEMENT (CONT)

CLEANING

Use general cleaning methods to clean all parts (page 2-30).

INSPECTION

Inspect all parts for wear or damage.

INSTALLATION

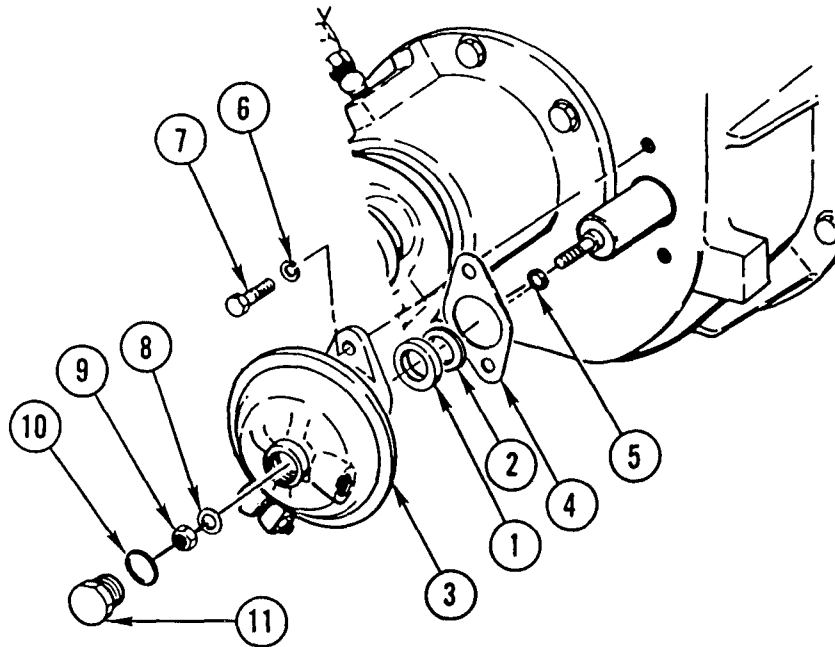

1. INSTALL NEW SEAL (1) AND PILOT RING (2) IN AIR SHIFT CHAMBER (3).

WARNING

Adhesives, solvents, and sealing compounds can burn easily, can give off harmful vapors, and are harmful to skin and clothing. To avoid injury or death, keep away from open fire and use in well-ventilated area. If adhesive, solvent, or sealing compound gets on skin or clothing, wash immediately with soap and water.

2. COAT BOTH SIDES OF NEW GASKET (4) WITH SILICONE ADHESIVE-SEALANT AND INSTALL ON AIR SHIFT CHAMBER (3).

3. INSTALL WASHER (5), AIR SHIFT CHAMBER (3), TWO NEW LOCK WASHERS (6), AND TWO SCREWS (7).
4. INSTALL WASHER (8), NEW LOCK NUT (9), NEW PACKING (10), AND PLUG (11).

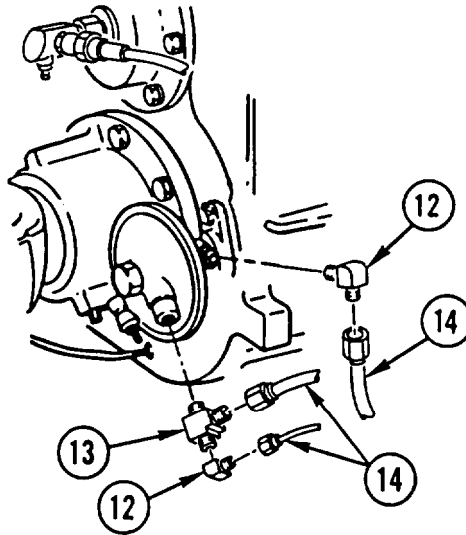

5. COAT THREADS OF TWO ELBOWS (12) AND TEE (13) WITH PIPE THREAD SEALING COMPOUND.
6. INSTALL TWO ELBOWS (12), TEE (13), AND THREE AIR HOSES (14).

NOTE

Follow-on Maintenance:
Fill transfer case with oil (TM 9-2320-363-20).

TRANSFER CASE YOKE AND SEAL REPLACEMENT

This task covers: a. Removal b. Cleaning c. Inspection d. Repair e. Installation

INITIAL SETUP

Applicable Configuration:

All except M915A2

Tools and Special Equipment:

Shop Equipment, SC 4910-95CL-A31
Tool Kit, SC 5180-90-CL-N05

Materials/Parts:

Seal, Oil	P/N 55079AX
Grease, Automotive and Artillery (GAA)	Appendix B, Item 26
Adhesive-Sealant, Silicone	Appendix B, Item 3

References:

TM 9-2320-363-20

Equipment Description:

Reference	Condition	Description
TM 9-2320-363-20	Driveline	Removed
TM 9-2320-363-20	Transfer Case	Oil Drained

General Safety Instructions:

<p style="text-align: center;">WARNING</p> <p>Adhesives, solvents, and sealing compounds can burn easily, can give off harmful vapors, and are harmful to skin and clothing. To avoid injury or death, keep away from open fire and use in well-ventilated area. If adhesive, solvent, or sealing compound gets on skin or clothing, wash immediately with soap and water.</p>

REMOVAL

NOTE

Procedure is the same for all yokes and oil seals.

1. REMOVE TWO SCREWS (1) AND LOCK PLATE (2) OR ONE SCREW (7) AND LOCK PLATE (8).
2. REMOVE YOKE (3) FROM SHAFT (4).
3. REMOVE AND DISCARD OIL SEAL (5) FROM BEARING CAP (6).

CLEANING

Use general cleaning methods to clean all parts (page 2-30).

INSPECTION

Inspect all parts for wear or damage.

REPAIR

Use general repair methods to repair damaged parts (page 2-33).

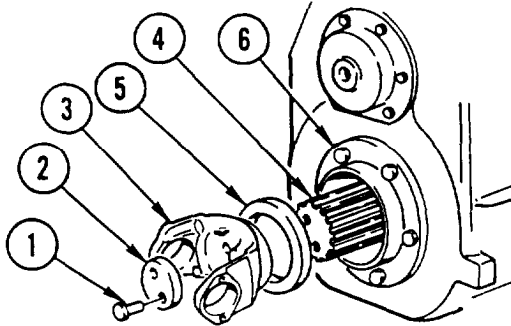

M916A1

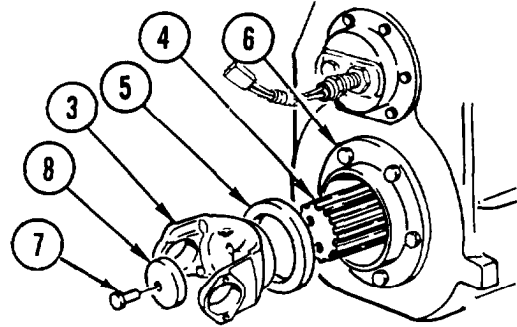

M916A2, M917A1, AND M917A1 w/MCS

INSTALLATION

1. COAT LIP OF NEW OIL SEAL (5) WITH GREASE
2. INSTALL OIL SEAL (5) IN BEARING CAP (6).

WARNING

Adhesives, solvents, and sealing compounds can burn easily, can give off harmful vapors, and are harmful to skin and clothing. To avoid injury or death, keep away from open fire and use in well-ventilated area. If adhesive, solvent, or sealing compound gets on skin or clothing, wash immediately with soap and water.

3. COAT END OF SHAFT (4) WITH SILICONE ADHESIVE-SEALANT.
4. INSTALL AND SEAT YOKE (3) ON SHAFT (4).
5. INSTALL LOCK PLATE (2) AND TWO SCREWS (1). TIGHTEN SCREWS TO 60 LB-FT (81 N.m).
6. INSTALL LOCK PLATE (8) AND ONE SCREW (7). TIGHTEN SCREW TO 308 LB-FT (418 N.m).

NOTE

Follow-on Maintenance:

Fill transfer case with oil (TM 9-2320-363-20).

Install driveline (TM 9-2320-363-20).

LUBRICATION PUMP REPLACEMENT

This task covers: a. Removal b. Cleaning c. Inspection d. Installation

INITIAL SETUP

Applicable Configuration:

All except M915A2

Tools and Special Equipment:

Shop Equipment, SC 4910-95-CL-A31
Tool Kit, SC 5180-90-CL-N05

Materials/Parts:

Washer, Lock (4)

Compound, Pipe Sealing Appendix B, Item 15

Adhesive-Sealant, Silicone Appendix B, Item 3

References:

TM 9-2320-363-20

Equipment Condition:

Reference	Condition Description
TM 9-2320-363-20	Transfer Case Oil Drained

General Safety Instructions:

WARNING

Adhesives, solvents, and sealing compounds can burn easily, can give off harmful vapors, and are harmful to skin and clothing. To avoid injury or death, keep away from open fire and use in well-ventilated area. If adhesive, solvent, or sealing compound gets on skin or clothing, wash immediately with soap and water.

REMOVAL

1. REMOVE LUBRICATION HOSE (1) AND FITTING (2).
2. REMOVE FOUR SCREWS (3) AND FOUR LOCK WASHERS (4). DISCARD LOCK WASHERS.
3. REMOVE LUBRICATION PUMP (5) FROM BEARING COVER (6).
4. REMOVE PLUG (7) FROM LUBRICATION PUMP (5).

CLEANING

Use general cleaning methods to clean all parts (page 2-30).

INSPECTION

Inspect all parts for wear or damage

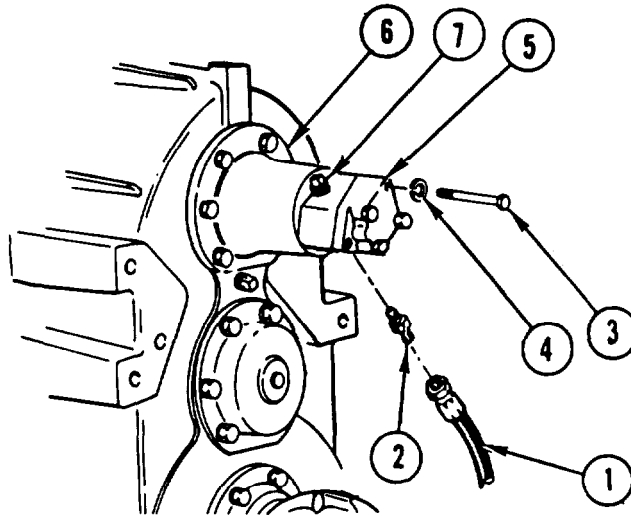

INSTALLATION

WARNING

Adhesives, solvents, and sealing compounds can burn easily, can give off harmful vapors, and are harmful to skin and clothing. To avoid injury or death, keep away from open fire and use in well-ventilated area. If adhesive, solvent, or sealing compound gets on skin or clothing, wash immediately with soap and water.

1. COAT PIPE THREADS OF FITTING (2) WITH PIPE THREAD SEALING COMPOUND AND INSTALL FITTING (2) IN LUBRICATION PUMP (5).
2. COAT PUMP MOUNTING SURFACE OF BEARING COVER (6) WITH SILICONE ADHESIVE-SEALANT.
3. INSTALL LUBRICATION PUMP (5) ON BEARING COVER (6) WITH FOUR NEW LOCK WASHERS (4) AND FOUR SCREWS (3). TIGHTEN SCREWS TO 15 LB-FT (20 N.m).
4. INSTALL LUBRICATION HOSE (1).
5. COAT THREADS OF PLUG (7) WITH PIPE THREAD SEALING COMPOUND AND INSTALL PLUG (7).

NOTE

Follow-on Maintenance:
Fill transfer case with oil (TM 9-2320-363-20).

CHAPTER 4 ELECTRICAL SYSTEM MAINTENANCE

OVERVIEW

This chapter illustrates and describes procedures for maintenance of the electrical system and related parts. A list of tasks contained in this chapter is shown below.

	Page
Injector Wiring Harness Replacement	4-2 . 2
Chassis Wiring Harness Replacement	4-6
Engine Wiring Harness Replacement	4-8
Stop/Tail/Backup Lights Wiring Harness Replacement	4-10
Turn Signal/Marker Light Wiring Harness Replacement	4-12
Turn Signal (Thru-Deck) Wiring Harness Replacement	4-14
Electronic Control Module Wiring Harness Replacement	4-16
Engine Power Wiring Harness Replacement	4-18
STE-ICE Wiring Harness Replacement	4-20
Main Cab Wiring Harness Replacement	4-22
Overhead Cab Wiring Harness Replacement	4-36
Cab Floor Anti-Lock Brake System (ABS) Wiring Harness Replacement (M915A2 and M916A1).....	4 - 3 8
Switch Panel Wiring Harnesses Replacement	4-40.2
Cab Anti-Lock Brake System (ABS) Wiring Harness Replacement (M915A2 and M916A1)	4-42
Cab Anti-Lock Brake System (ABS) Wiring Harness Replacement (M916A2 and M917A1)	4 - 4 4
Front Anti-Lock Brake System (ABS) Wiring Harness Replacement (M915A2 and M916A1)	4 - 4 4 . 2
Front Anti-Lock Brake System (ABS) Wiring Harness Replacement (M916A2 and M917A1)	4-46.2
Rear Anti-Lock Brake System (ABS) Wiring Harness Replacement (M916A2 and M917A1)	4-46.4
Rear Anti-Lock Brake System (ABS) Wiring Harness Replacement (M915A2 and M916A1)	4-46 . 6

OVERVIEW (CON'T)

MCS Chassis Wiring Harness Replacement (M917A1 w/MCS) 4-47.2
CTIS Wiring Harness Replacement (M917A1 and M917A1 w/MCS) 4-47.4
PTO Wiring Harness Replacement (All Except M915A2) 4-47.6
MCS Cab Wiring Harness Replacement (M917A1 w/MCS) 4-47.9
Starter Solenoid Replacement 4-48
Engine Retarder Solenoid Test and Replacement 4-50

INJECTOR WIRING HARNESS REPLACEMENT

This task covers: a. Removal b. Cleaning c. Inspection d. Installation

INITIAL SETUP

Tools and Special Equipment:

Shop Equipment, SC 4910-95-CL-A31
Tool Kit, SC 5180-90-CL-N05

Equipment Condition:

Reference

Page 3-71

Condition Description

Rocker Cover Removed

REMOVAL

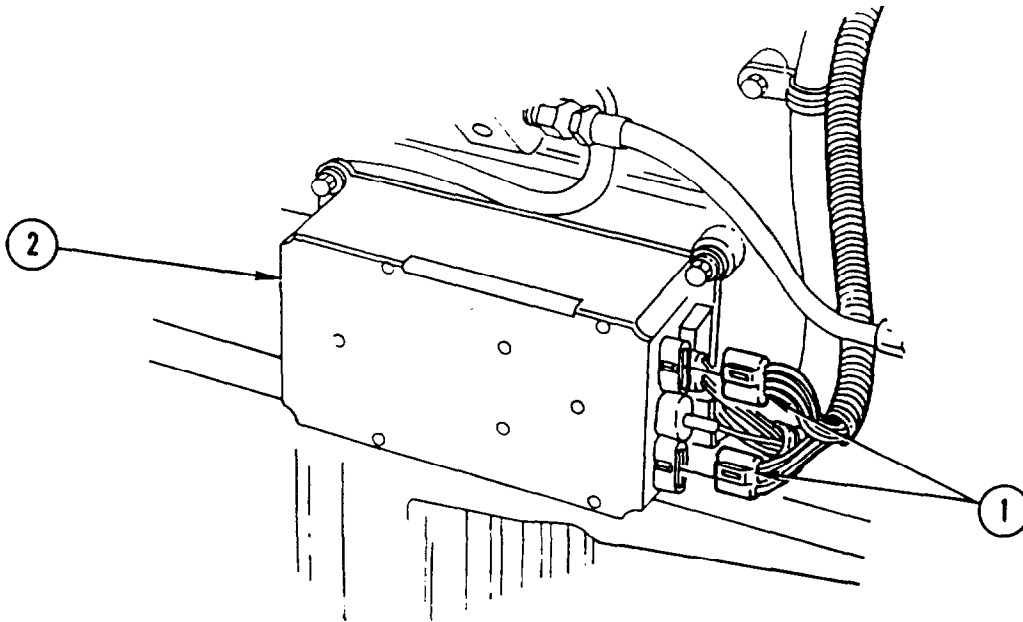

CAUTION

- Grasp connector and terminal body when removing wiring harness connectors. Do not pull on wires or harness to prevent damage to equipment.
- Injector wiring harness connectors are top and bottom connectors at rear of electronic control module. Do not remove center outboard connector.

1. DISCONNECT LOCKING TANGS ON TWO INJECTOR WIRING HARNESS CONNECTORS (1) AT REAR OF ELECTRONIC CONTROL MODULE (2) AND PULL CONNECTORS (1) OUT OF TOP AND BOTTOM OUTBOARD TERMINALS.

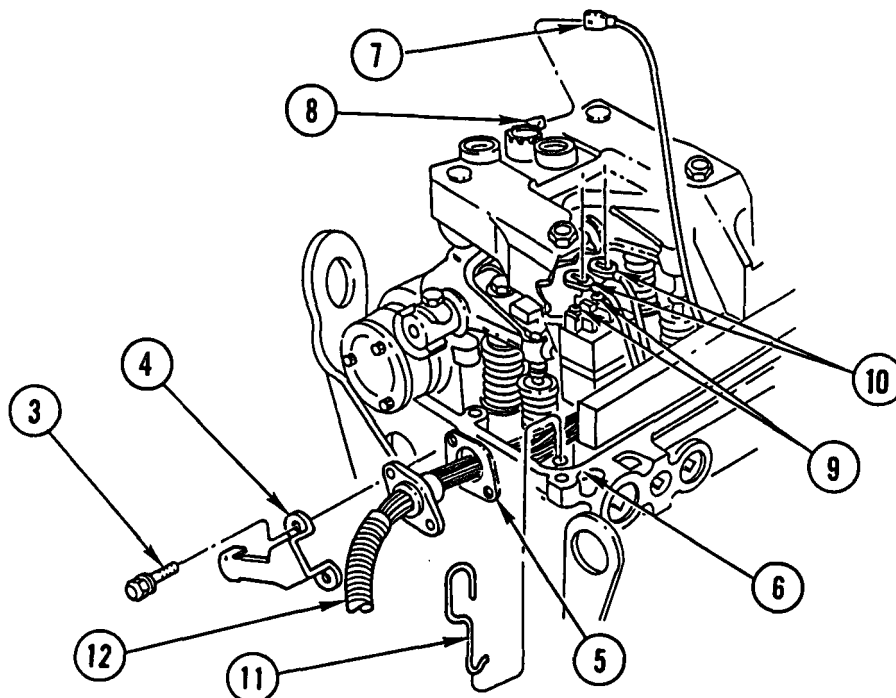

2. REMOVE TWO BOLTS (3) AND HARNESS PROTECTOR (4) FROM HARNESS PLATE (5) AT REAR OF CYLINDER HEAD (6).
3. DISCONNECT HARNESS LEADS (7) FROM THREE ENGINE RETARDER SOLENOID TERMINALS (8).

NOTE

- Do not remove terminal screws from injector. Loosen terminal screws only enough to allow larger opening in terminal to be moved under screw head, allowing terminal to be lifted off.
- Tag terminals prior to removal to aid in installation.

4. LOOSEN TWO TERMINAL SCREWS (9) ON EACH INJECTOR AND REMOVE TERMINALS (10).
5. REMOVE GUIDE CLIP (11) IN REAR CORNER DRAIN HOLE OF CYLINDER HEAD (6).

NOTE

Feed wires and terminals thru hole at rear of cylinder head carefully.

6. REMOVE HARNESS (12).

CLEANING

Use general cleaning methods to clean all parts (page 2-30).

INSPECTION

Inspect all parts for wear or damage.

INJECTOR WIRING HARNESS REPLACEMENT (CONT)

INSTALLATION

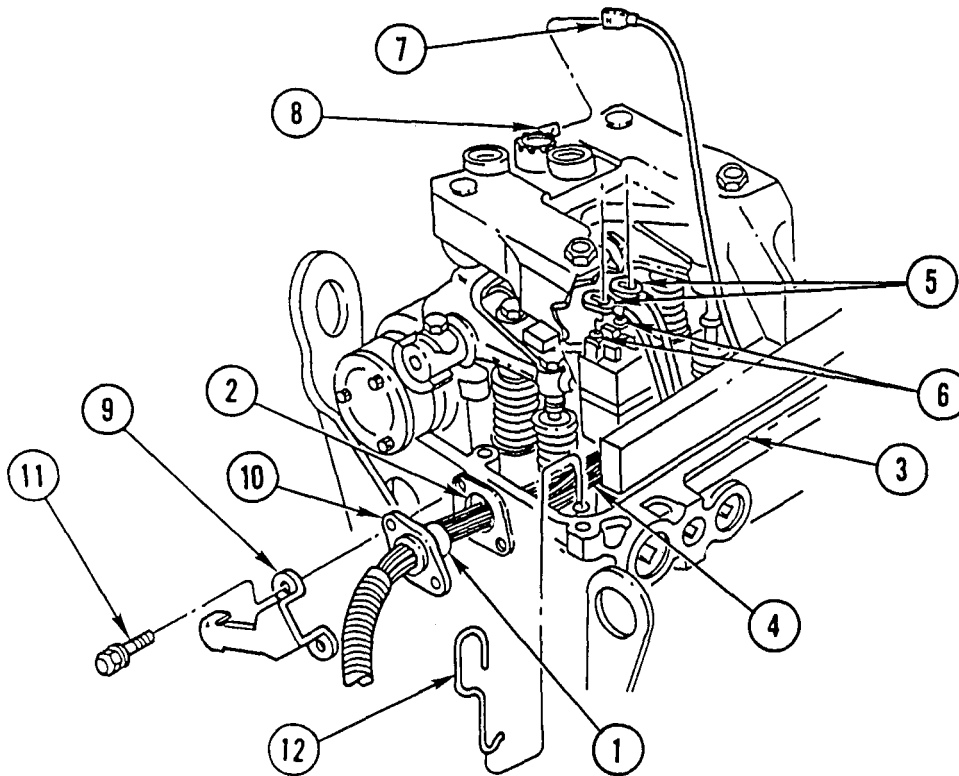

CAUTION

Do not pull on injector wires or terminals when installing harness in cylinder head to prevent damage to equipment.

NOTE

All connectors should reach terminals without strain or repositioning of injector wire when harness is installed correctly.

1. FEED HARNESS (1) INTO CYLINDER HEAD HARNESS HOLE (2) AT REAR OF CYLINDER HEAD (3).
2. POSITION INJECTOR WIRES (4) IN CYLINDER HEAD (3) SO WIRES FOLLOW INSIDE RAIL OF CYLINDER HEAD ON OIL COOLER SIDE OF ENGINE UNDER ENGINE RETARDER ASSEMBLY.
3. BEGIN WITH TWO LONGEST INJECTOR WIRES AND INSTALL TERMINALS (5) OVER SCREWS (6) ON NO. 1 (FRONT) INJECTOR. TIGHTEN SCREWS TO 12-17 LB-IN. (1.25-1.92 N.m).
4. FOLLOW SAME PROCEDURE FOR INSTALLING REMAINING INJECTOR WIRES.

5. INSTALL HARNESS LEAD (7) ON ENGINE RETARDER SOLENOID TERMINAL (8).
6. FOLLOW SAME PROCEDURE FOR INSTALLING REMAINING TWO HARNESS LEADS ON ENGINE RETARDER SOLENOID TERMINALS.
7. ALINE BOLT HOLES OF HARNESS PROTECTOR (9) AND HARNESS PLATE (10) WITH BOLT HOLES IN CYLINDER HEAD. INSTALL TWO BOLTS (11) AND HARNESS PROTECTOR (9) ON HARNESS PLATE (10). TIGHTEN BOLTS TO 7-11 LB-FT (10-15 N.m).

NOTE

Make sure injector wires are positioned against cylinder head rail away from possible contact with exhaust valve springs.

8. INSERT GUIDE CLIP (12) INTO OIL DRAIN HOLE AT REAR OF CYLINDER HEAD (3) TO RETAIN INJECTOR WIRES IN CORNER AWAY FROM EXHAUST VALVE SPRINGS.

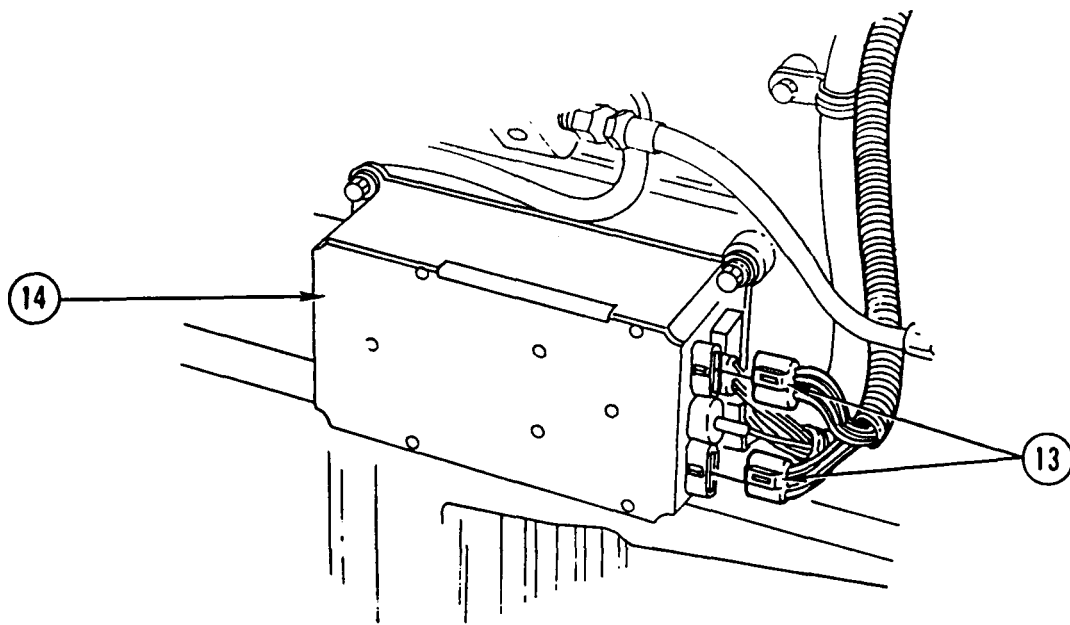

NOTE

Install black connector in bottom terminal and grey connector in top terminal. Connectors have different guide ridges that correspond to grooves in terminals.

9. INSERT TWO INJECTOR WIRING HARNESS CONNECTORS (13) INTO TOP AND BOTTOM OUTBOARD TERMINALS OF ELECTRONIC CONTROL MODULE (14). MAKE SURE LOCKING TANGSON INJECTOR WIRING HARNESS CONNECTORS ARE ENGAGED.

NOTE

Follow-on Maintenance:
Install rocker cover (page 3-71).

CHASSIS WIRING HARNESS REPLACEMENT

This task covers: a. Removal b. Cleaning c. Inspection d. Installation

INITIAL SETUP

Tools and Special Equipment:

Shop Equipment, SC 4910-95-CL-A31
Tool Kit, SC 5180-90-CL-N05

Equipment Condition:

Reference	Condition Description
TM 9-2320-363-20	Batteries Disconnected

References:

TM 9-2320-363-20

REMOVAL

NOTE

- Wiring harness and leads are secured in place by wire ties, cushion clamps, and screw terminals.
- Only remove hardware securing harness or lead to be removed.

Disconnect AND REMOVE CHASSIS WIRING HARNESS USING ILLUSTRATION AND TABLE AS A GUIDE.

CLEANING

Use general cleaning methods to clean all parts (page 2-30).

INSPECTION

Inspect all parts for wear or damage.

NOTE

- Wiring harness and leads are secured in place by wire ties, cushion clamps, and screw terminals.
- Make sure harness is secure and all hardware is tight.

INSTALL AND CONNECT CHASSIS WIRING HARNESS USING ILLUSTRATION AND TABLE AS A GUIDE.

NOTE

Follow-on Maintenance:
Connect batteries (TM 9-2320-363-20).

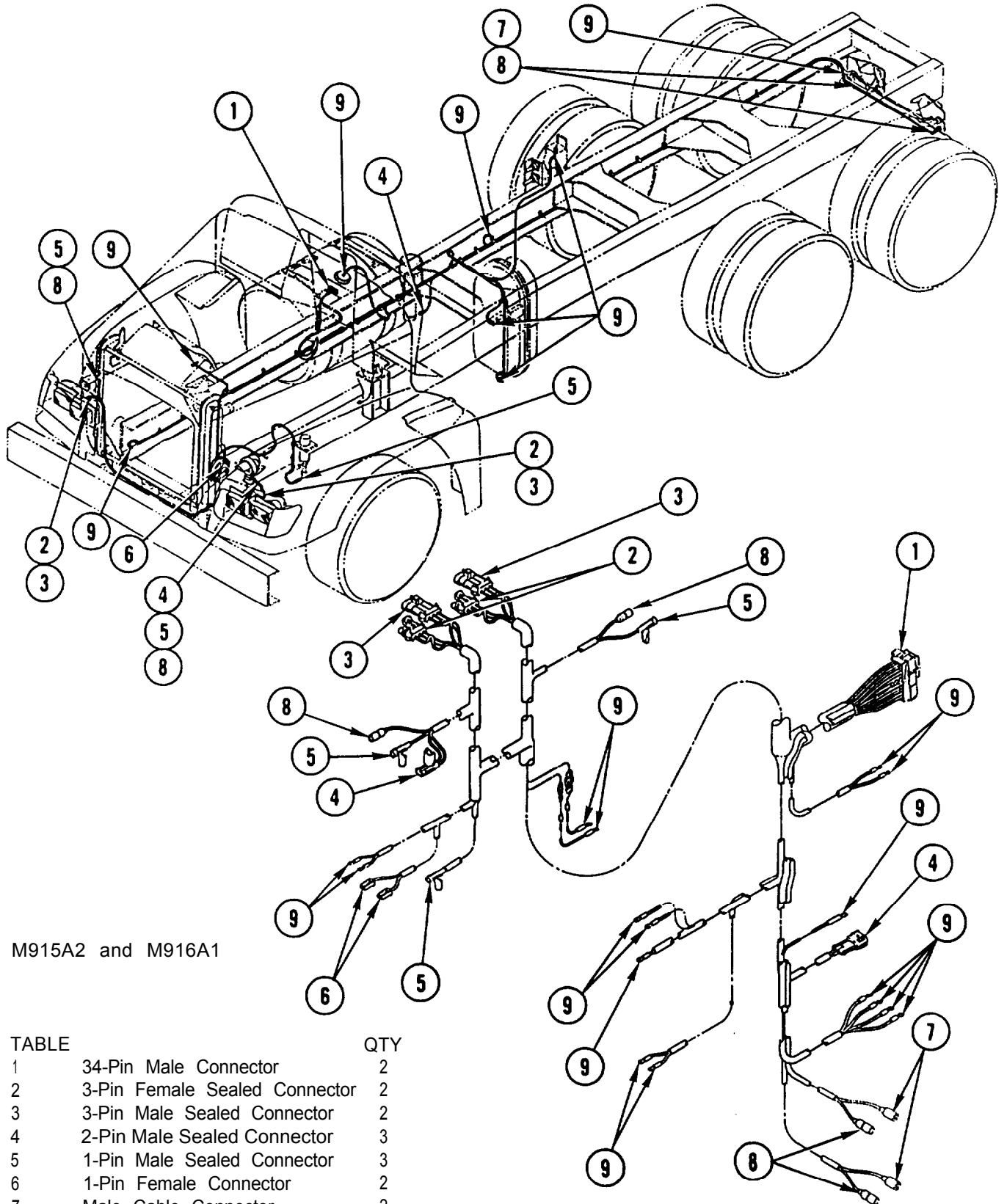

M915A2 and M916A1

TABLE		QTY
1	34-Pin Male Connector	2
2	3-Pin Female Sealed Connector	2
3	3-Pin Male Sealed Connector	2
4	2-Pin Male Sealed Connector	3
5	1-Pin Male Sealed Connector	3
6	1-Pin Female Connector	2
7	Male Cable Connector	2
8	Female Cable Connector	4
9	Ring Terminal	17

CHASSIS WIRING HARNESS REPLACEMENT (CONT)

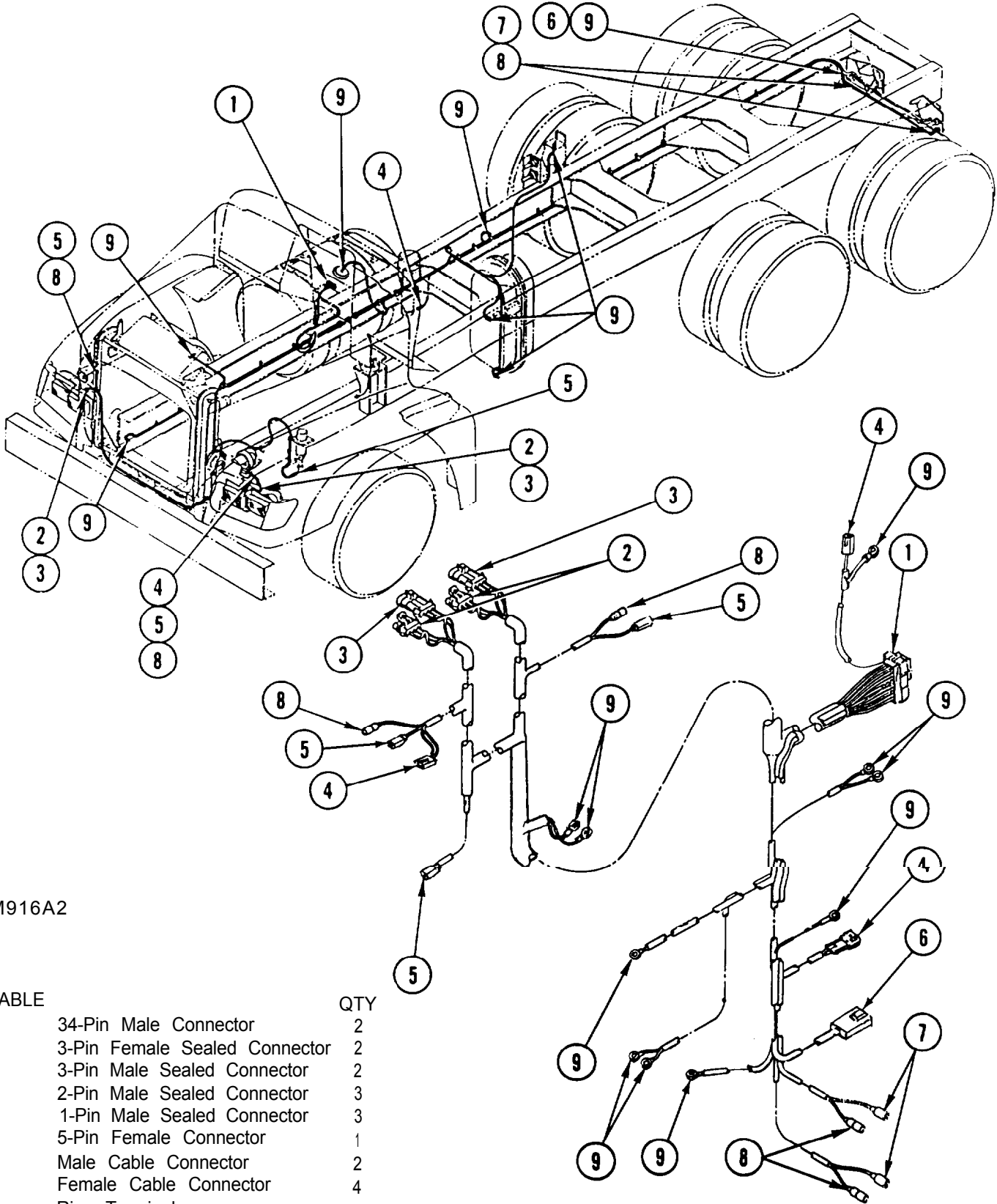

M916A2

TABLE		QTY
1	34-Pin Male Connector	2
2	3-Pin Female Sealed Connector	2
3	3-Pin Male Sealed Connector	2
4	2-Pin Male Sealed Connector	3
5	1-Pin Male Sealed Connector	3
6	5-Pin Female Connector	1
7	Male Cable Connector	2
8	Female Cable Connector	4
9	Ring Terminal	10

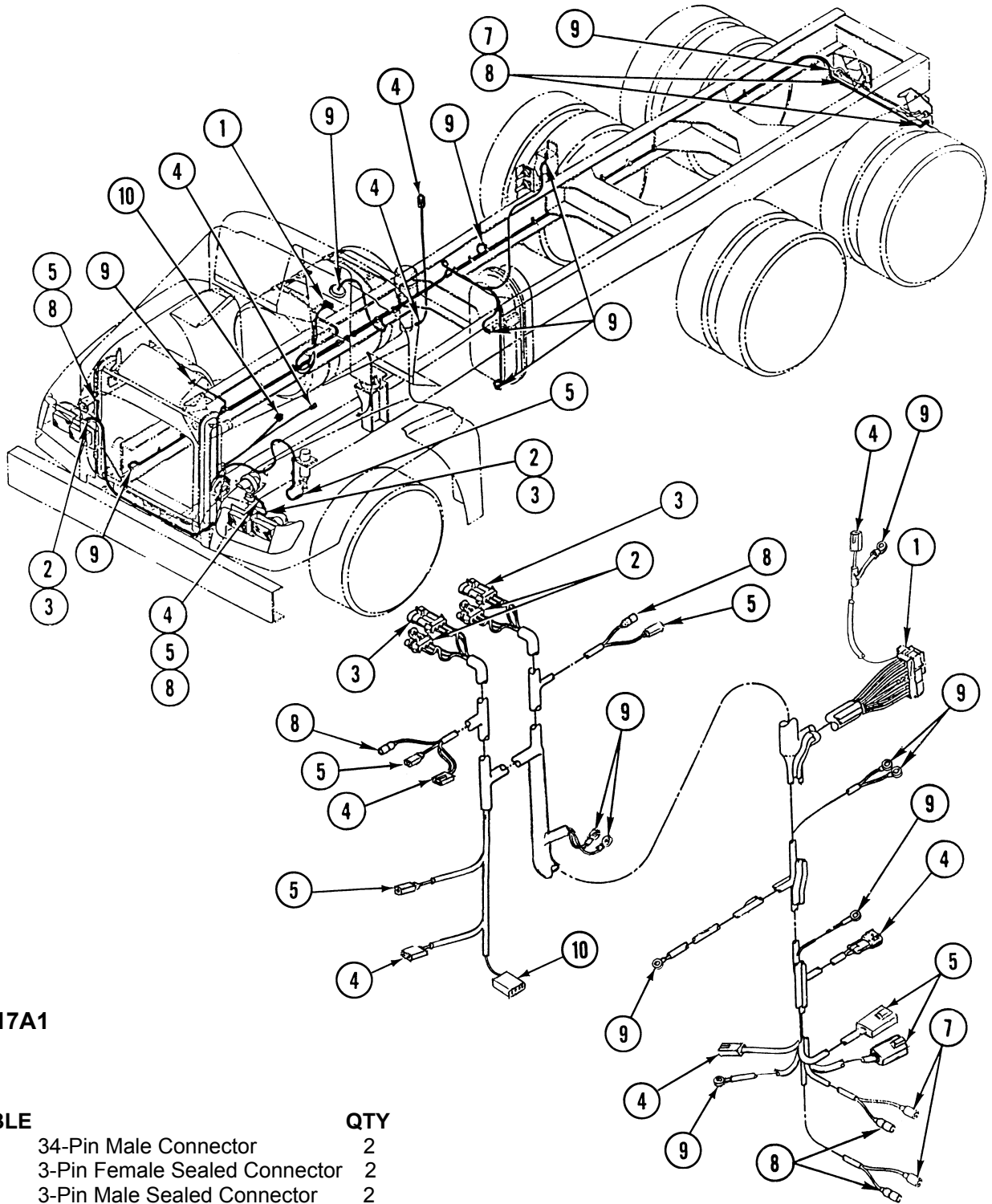

M917A1

TABLE		QTY
1	34-Pin Male Connector	2
2	3-Pin Female Sealed Connector	2
3	3-Pin Male Sealed Connector	2
4	2-Pin Male Sealed Connector	5
5	1-Pin Male Sealed Connector	4
6	5-Pin Female Connector	2
7	Male Cable Connector	2
8	Female Cable Connector	4
9	Ring Terminal	7
10	4-Pin Male Sealed Connector	1

ENGINE WIRING HARNESS REPLACEMENT

This task covers: a. Removal b. Cleaning c. Inspection d. Installation

INITIAL SETUP

Tools and Special Equipment:

Shop Equipment, SC 4910-95-CL-A31
Tool Kit, SC 5180-90-CL-N05

Equipment Condition:

Reference	Condition	Description
TM 9-2320-363-20	Batteries	Disconnected

References:

TM 9-2320-363-20

REMOVAL

NOTE

- Wiring harness and leads are secured in place by wire ties, cushion clamps, and screw terminals.
- Only remove hardware securing harness or lead to be removed.

DISCONNECT AND REMOVE ENGINE WIRING HARNESS USING ILLUSTRATION AND TABLE AS A GUIDE.

CLEANING

Use general cleaning methods to clean all parts (page 2-30).

INSPECTION

Inspect all parts for wear or damage

INSTALLATION

NOTE

- Wiring harness and leads are secured in place by wire ties, cushion clamps, and screw terminals.
- Make sure harness is secure and all hardware is tight.

INSTALL AND CONNECT ENGINE WIRING HARNESS USING ILLUSTRATION AND TABLE AS A GUIDE.

NOTE

Follow-on Maintenance:

Connect batteries (TM 9-2320-363-20).

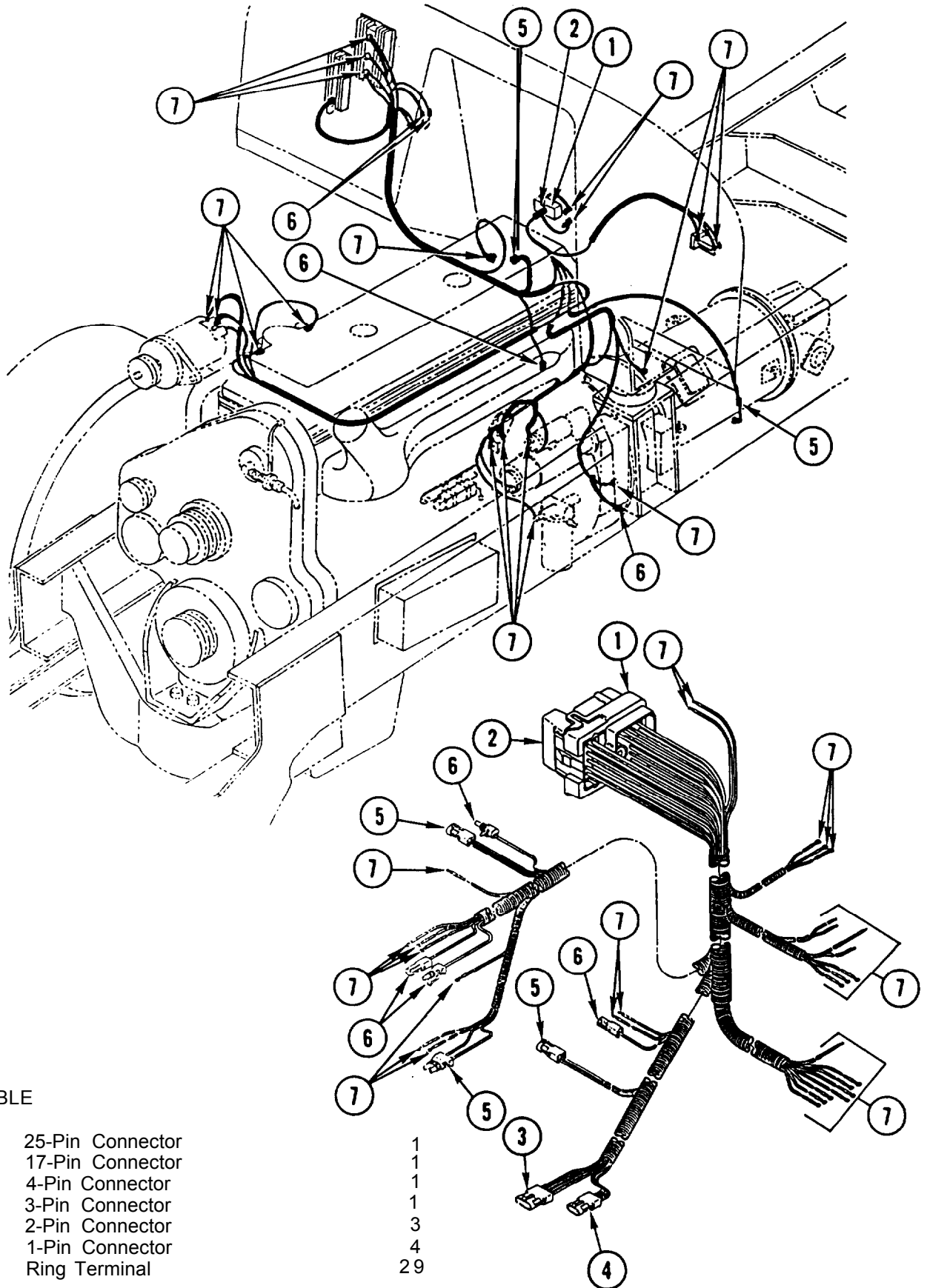

TABLE

- 1 25-Pin Connector
- 2 17-Pin Connector
- 3 4-Pin Connector
- 4 3-Pin Connector
- 5 2-Pin Connector
- 6 1-Pin Connector
- 7 Ring Terminal

1
1
1
1
3
4
29

TM 9-2320-363-34-1

■ All data on pages 4-10 and 4-11 deleted

All data on pages 4-10 and 4-11 deleted.



TURN SIGNAL/MARKER LIGHT WIRING HARNESS REPLACEMENT

This task covers: a. Removal b. Cleaning c. Inspection d. Installation

Tools and Special Equipment:

Tool Kit, SC 5180-90-CL-N05

References:

TM 9-2320-363-20

Equipment Condition:

Reference

TM 9-2320-363-20

Condition Description

Batteries Disconnected

REMOVAL

NOTE

- Procedure is the same for both wiring harnesses.
- Wiring harness and leads are secured in place by clips, wire ties, cushion clamps, and screw terminals.
- Only remove hardware securing harness or lead to be removed.

DISCONNECT AND REMOVE TURN SIGNAL/MARKER LIGHT WIRING HARNESS USING ILLUSTRATION AND TABLE AS A GUIDE.

CLEANING

Use general cleaning methods to clean all parts (page 2-30).

INSPECTION

Inspect all parts for wear or damage.

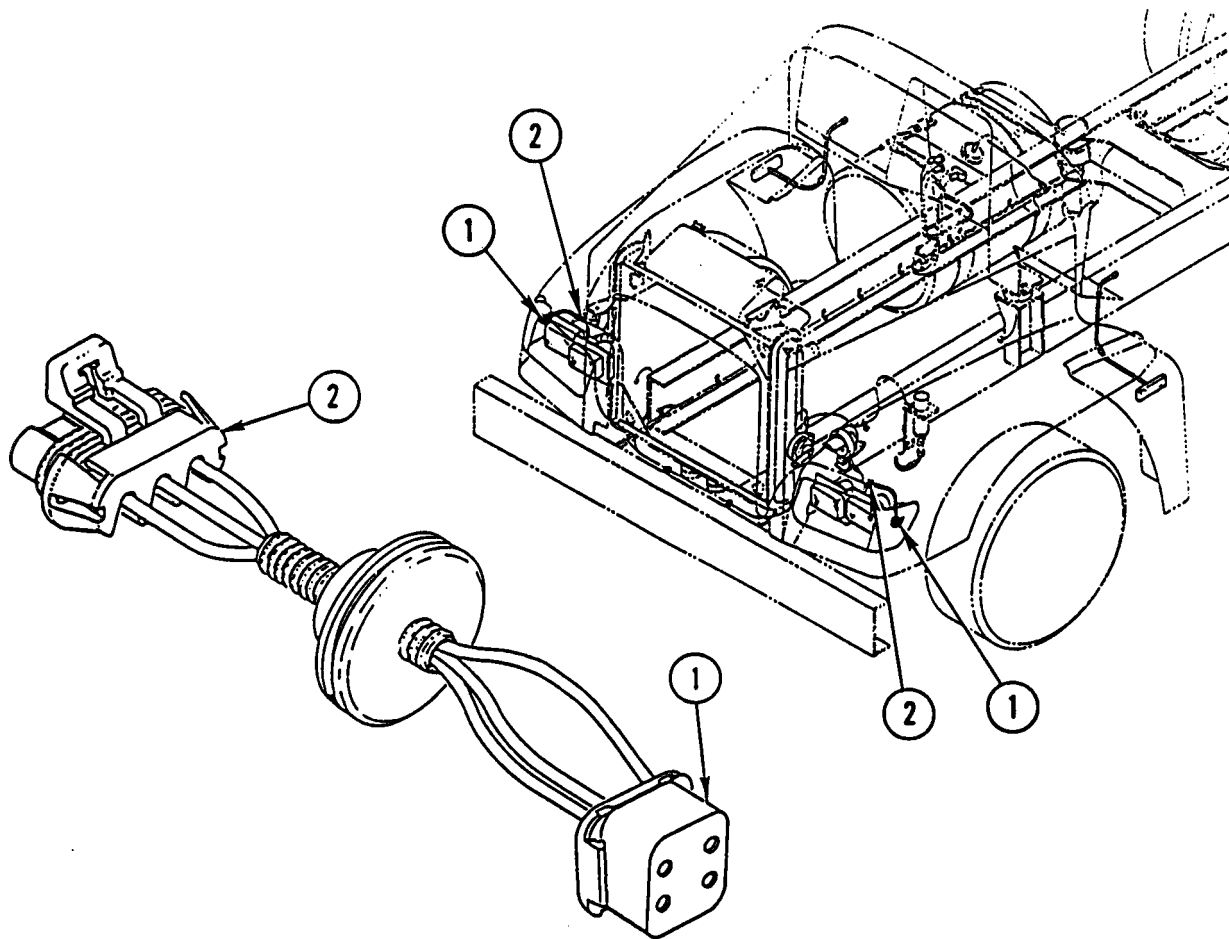

TABLE	QTY
1 4-Pin Female Connector	2
2 3-Pin Female Sealed Connector	2

INSTALLATION

NOTE

- Procedure is the same for both wiring harnesses.
- Wiring harness and leads are secured in place by clips, wire ties, cushion clamps, and screw terminals.
- Make sure harness is secure and all hardware is tight.

INSTALL TURN SIGNAL/MARKER LIGHT WIRING HARNESS USING ILLUSTRATION AND TABLE AS A GUIDE.

NOTE

Follow-on Maintenance:
Connect batteries (TM 9-2320-363-20).

TURN SIGNAL (THRU-DECK) WIRING HARNESS REPLACEMENT

This task covers: a. Removal b. Cleaning c. Inspection d. Installation

INITIAL SETUP

Tools and Special Equipment:

Tool Kit, SC 5180-90-CL-N05

References:

TM 9-2320-363-20

Equipment Condition:

Reference

TM 9-2320-363-20

Condition Description

Batteries Disconnected

REMOVAL

NOTE

- Procedure is the same for both wiring harnesses.
- Wiring harness and leads are secured in place by clips, wire ties, cushion clamps, and screw terminals.
- Only remove hardware securing harness or lead to be removed.

DISCONNECT AND REMOVE TURN SIGNAL (THRU-DECK) WIRING HARNESS USING ILLUSTRATION AND TABLE AS A GUIDE.

CLEANING

Use general cleaning methods to clean all parts (page 2-30).

INSPECTION

Inspect all parts for wear or damage.

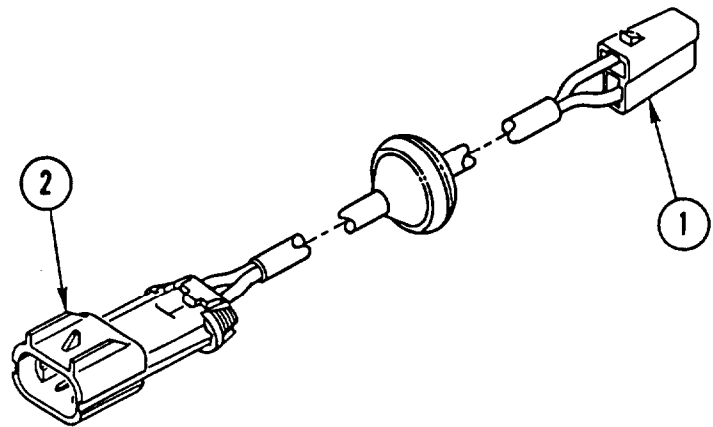
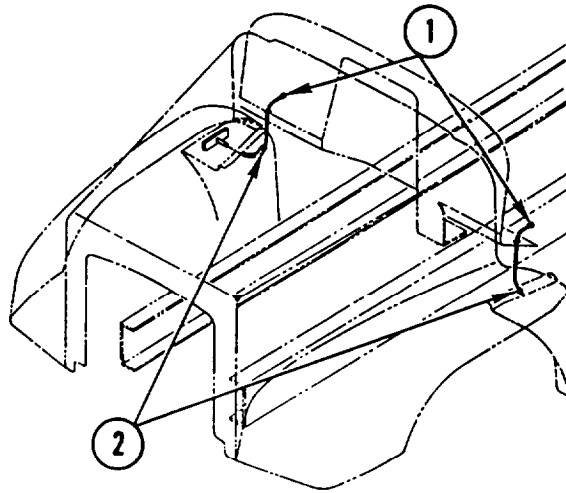

TABLE

1 2-Pin Female Connector
 2 2-Pin Male Sealed Connector

QTY

1
 1

INSTALLATION

NOTE

- Procedure is the same for both wiring harnesses.
- Wiring harness and leads are secured in place by clips, wire ties, cushion clamps, and screw terminals.
- Make sure harness is secure and hardware is tight,

INSTALL AND CONNECT TURN SIGNAL (THRU-DECK) WIRING HARNESS USING ILLUSTRATION AND TABLE AS A GUIDE.

NOTE

Follow-on Maintenance:
 Connect batteries (TM 9-2320-363-20).

ELECTRONIC CONTROL MODULE WIRING HARNESS REPLACEMENT

This task covers: a. Removal b. Cleaning c. Inspection d. Installation

INITIAL SETUP

Tools and Special Equipment:

Tool Kit, SC 5180-90-CL-N05

Materials/Parts:

Strap, Tie-down Appendix B, Item 54.1

References:

TM 9-2320-363-20

Equipment Condition:

Reference	Condition	Description
TM 9-2320-363-20	Batteries	Disconnected

REMOVAL

NOTE

- Wiring harness and leads are secured in place by cushion clamps and screws and tie-down straps.
- Only remove hardware securing harness or lead to be removed.

DISCONNECT AND REMOVE ELECTRONIC CONTROL MODULE WIRING HARNESS USING ILLUSTRATION AND TABLE AS A GUIDE.

CLEANING

Use general cleaning methods to clean all parts (page 2-30).

INSPECTION

Inspect all parts for wear or damage.

INSTALLATION

NOTE

- Wiring harness and leads are secured in place by cushion clamps and screws and tie-down straps.
- Only remove hardware securing harness or lead to be removed.

INSTALL AND CONNECT ELECTRONIC CONTROL MODULE WIRING HARNESS USING ILLUSTRATION AND TABLE AS A GUIDE.

NOTE

Follow-on Maintenance:

Connect batteries (TM 9-2320-363-20).

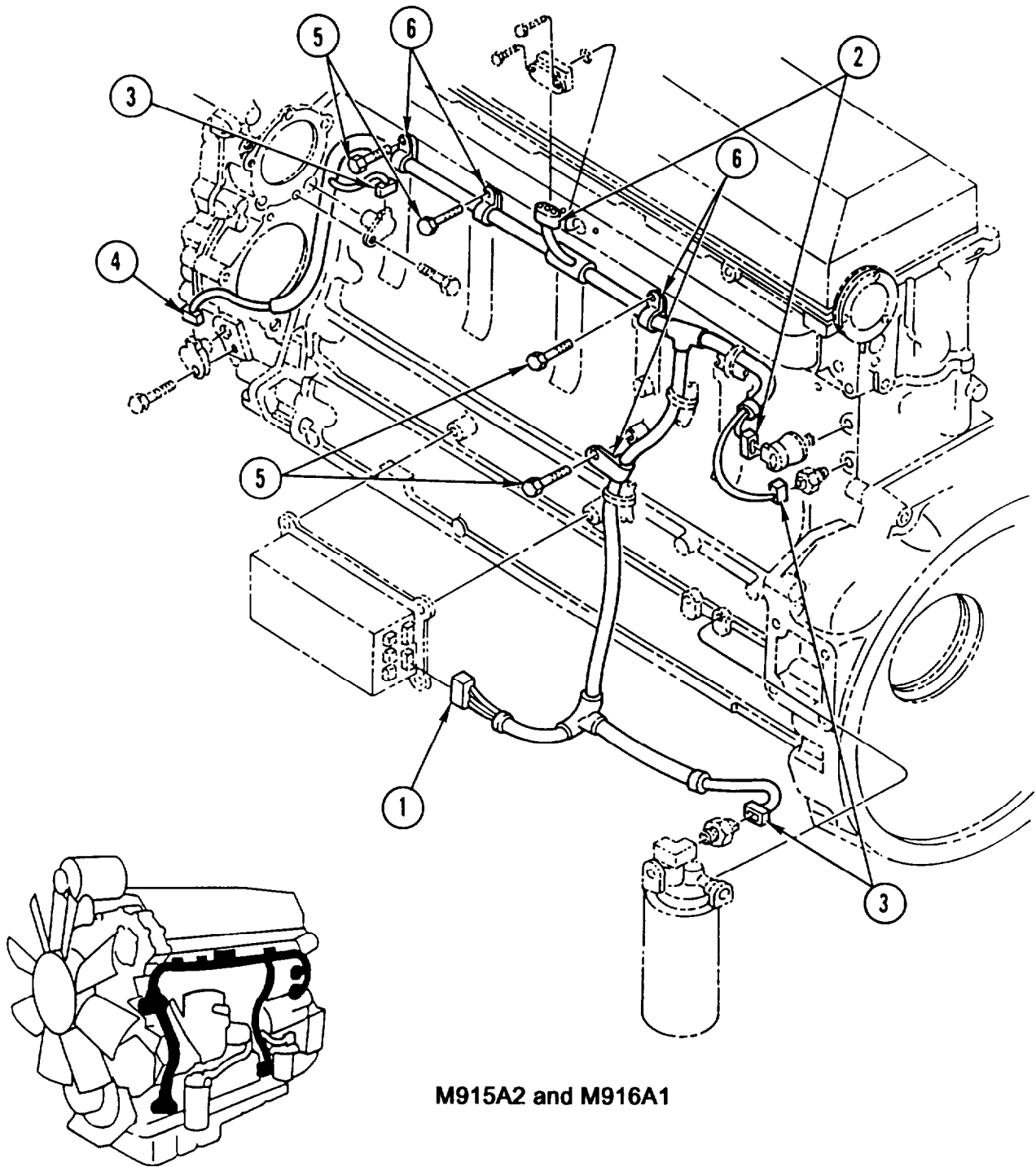

M915A2 and M916A1

TABLE

QTY

1	30-Pin Plug	1
2	3-Pin Connector	2
3	2-Pin Connector	3
4	Connector	4
5	Screw	5
6	Clamp	6

**ELECTRONIC CONTROL MODULE WIRING HARNESS REPLACEMENT
(CONT)**

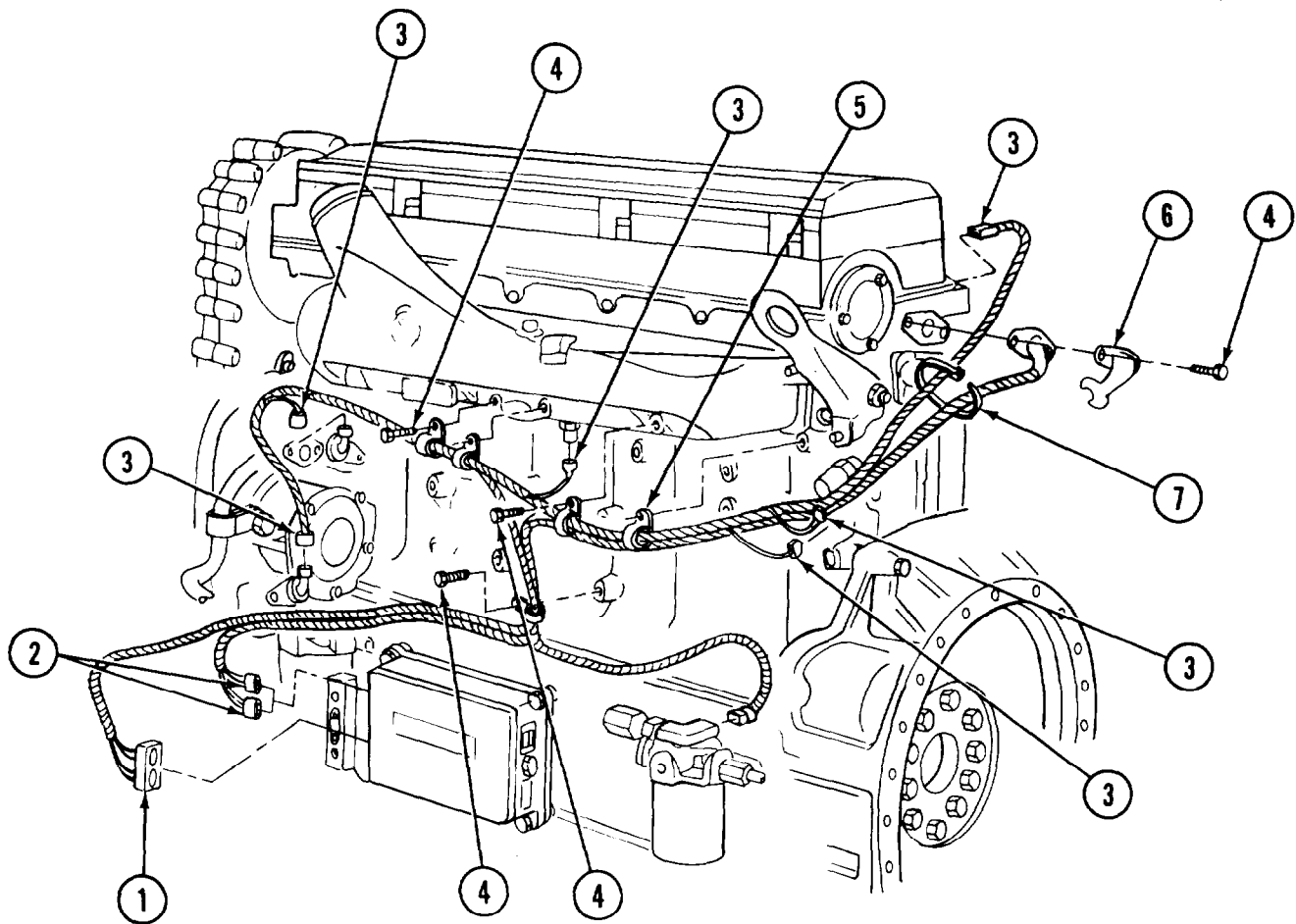

ALL EXCEPT M915A2 AND M916A1

TABLE		QTY
1	30-Pin Connector	1
2	5-Pin Connector	2
3	1-Pin Connector	6
4	Screw	7
5	Clamp	5
6	Cover	1
7	Tie Strap	9

THIS PAGE INTENTIONALLY LEFT BLANK

ENGINE POWER WIRING HARNESS REPLACEMENT

This task covers: a. Removal b. Cleaning c. Inspection d. Installation

INITIAL SETUP

Tools and Special Equipment:

Tool Kit, SC 5180-90-CL-N05

References:

TM 9-2320-363-20

Equipment Condition:

Reference

TM 9-2320-363-20

Condition Description

Batteries Disconnected

REMOVAL

NOTE

- Wiring harness and leads are secured in place by cushion clamps and screw terminals.
- Only remove hardware securing harness or lead to be removed.

DISCONNECT AND REMOVE ENGINE POWER WIRING HARNESS USING ILLUSTRATION AND TABLE AS A GUIDE.

CLEANING

Use general cleaning methods to clean all parts (page 2-30).

INSPECTION

Inspect all parts for wear or damage.

INSTALLATION

NOTE

- Wiring harness and leads are secured in place by cushion clamps and screw terminals.
- Make sure harness is secure and all hardware is tight.

INSTALL AND CONNECT ENGINE POWER WIRING HARNESS USING ILLUSTRATION AND TABLE AS A GUIDE.

NOTE

Follow-on Maintenance:
Connect batteries (TM 9-2320-363-20).

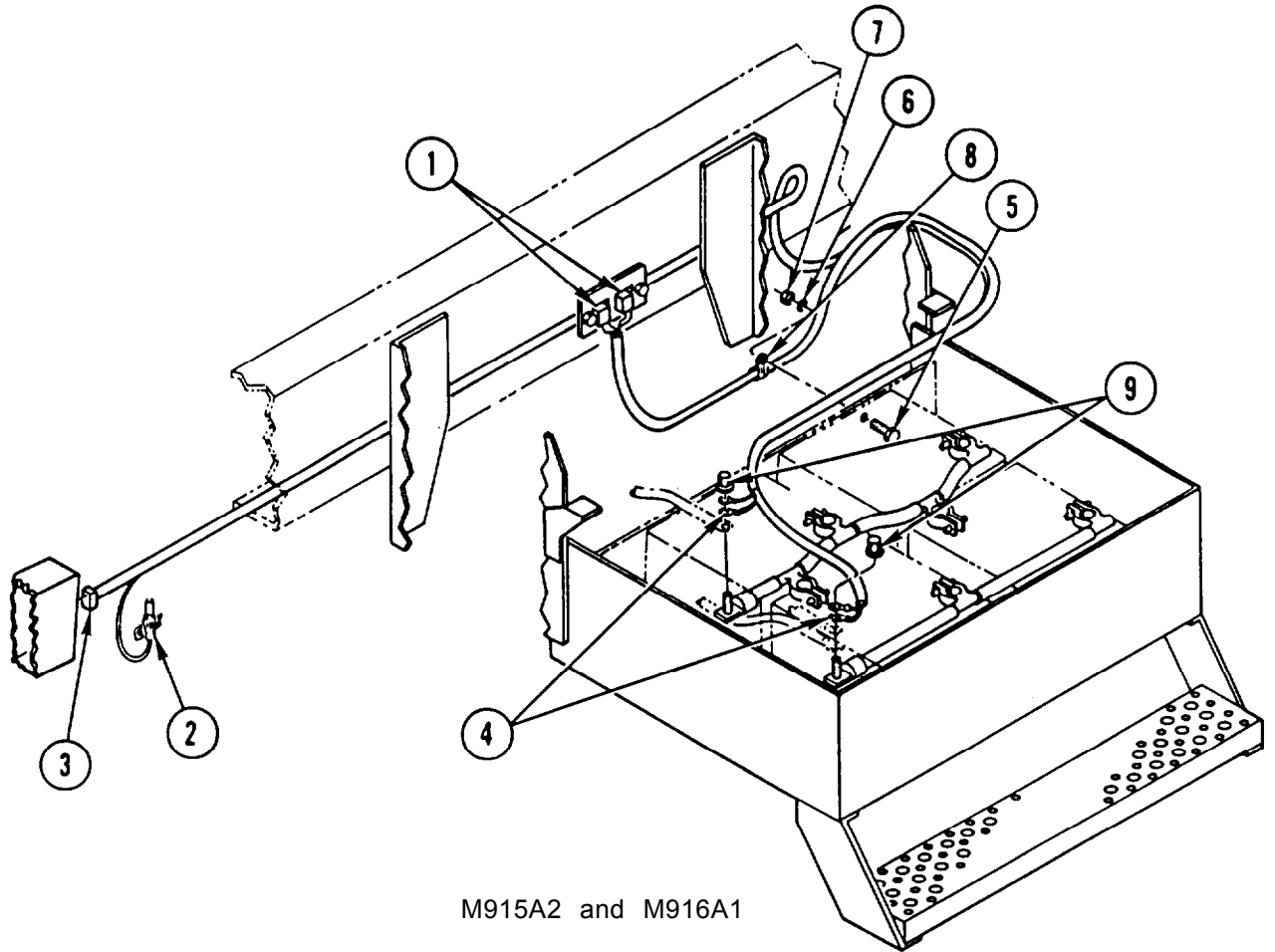
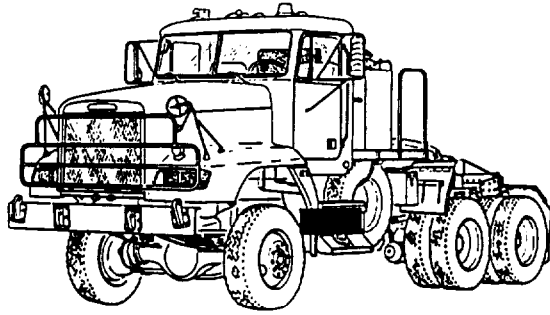

M915A2 and M916A1

TABLE

		QTY
1	Fuse Holder Plug	2
2	1-Pin Connector	1
3	6-Pin Connector	1
4	Terminal	4
5	Screw	1
6	Washer	1
7	Nut	1
8	Clamp	1
9	Crown Nut	2

ENGINE POWER WIRING HARNESS REPLACEMENT (CONT)

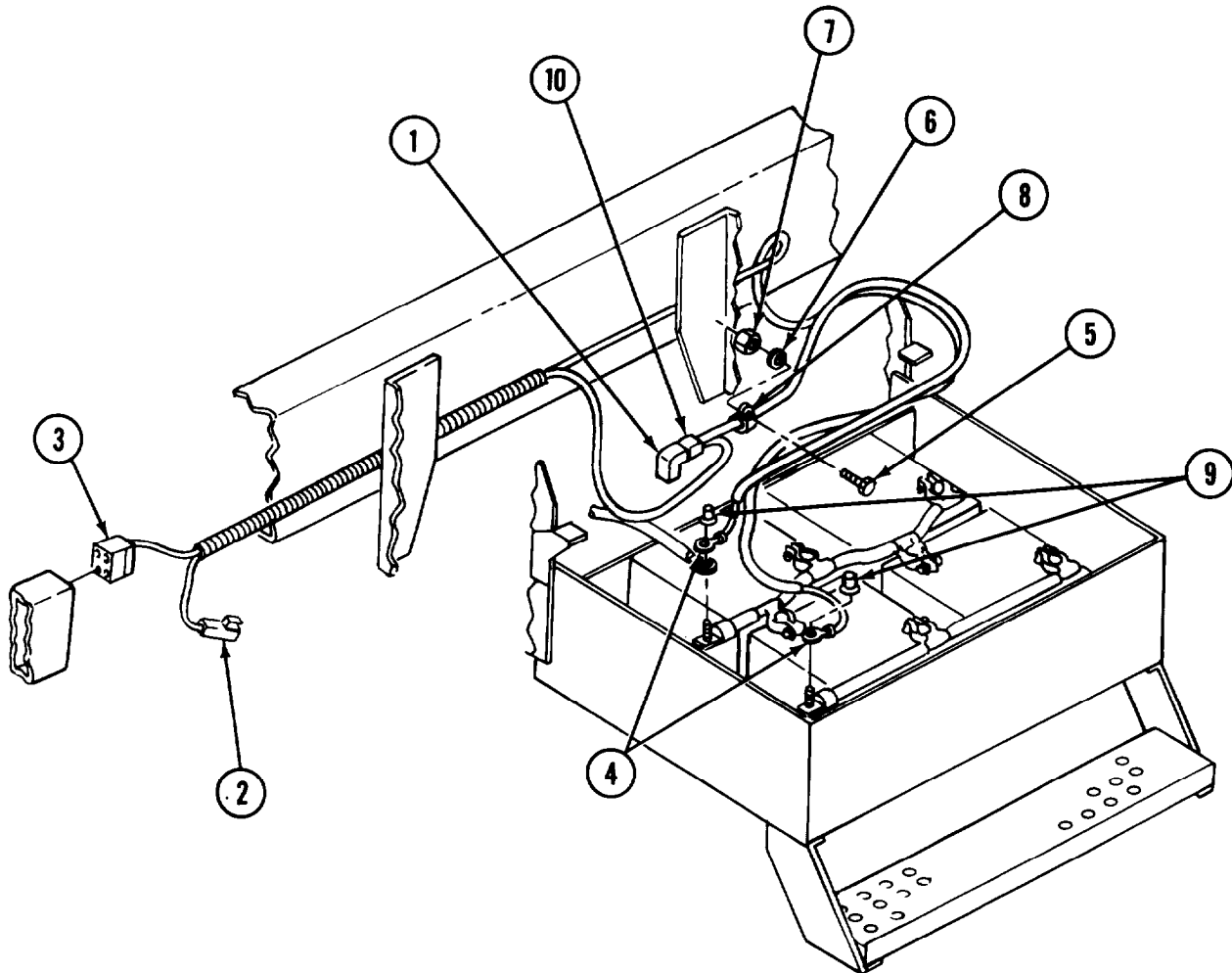

ALL EXCEPT M915A2 AND M916A1

TABLE		QTY
1	Fuse Holder	1
2	1-Pin Connector	1
3	5-Pin Connector	1
4	Ring Terminal	3
5	Screw	1
6	Washer	1
7	Nut	1
8	Clamp	1
9	Crown Nut	2
10	2-Pin Connector	1

THIS PAGE INTENTIONALLY LEFT BLANK

STE/ICE WIRING HARNESS REPLACEMENT

This task covers: a. Removal b. Cleaning c. Inspection d. Installation

INITIAL SETUP

Tools and Special Equipment:

Tool Kit, SC 5180-90-CL-N05

References:

TM 9-2320-363-20

Equipment Condition:

Reference

TM 9-2320-363-20

Condition Description

Batteries Disconnected

REMOVAL

NOTE

- Wiring harness and leads are secured in place by wire ties, cushion clamps, and screw terminals.
- Only remove hardware securing harness or lead to be removed.

DISCONNECT AND REMOVE STE-ICE WIRING HARNESS USING ILLUSTRATION AND TABLE AS A GUIDE.

CLEANING

Use general cleaning methods to clean all parts (page 2-30).

INSPECTION

Inspect all parts for wear or damage.

INSTALLATION

NOTE

- Wiring harness and leads are secured in place by wire ties, cushion clamps, and screw terminals.
- Make sure harness is secure and all hardware is tight.

INSTALL AND CONNECT STE-ICE WIRING HARNESS USING ILLUSTRATION AND TABLE AS A GUIDE.

NOTE

Follow-on Maintenance:

Connect batteries (TM 9-2320-363-20).

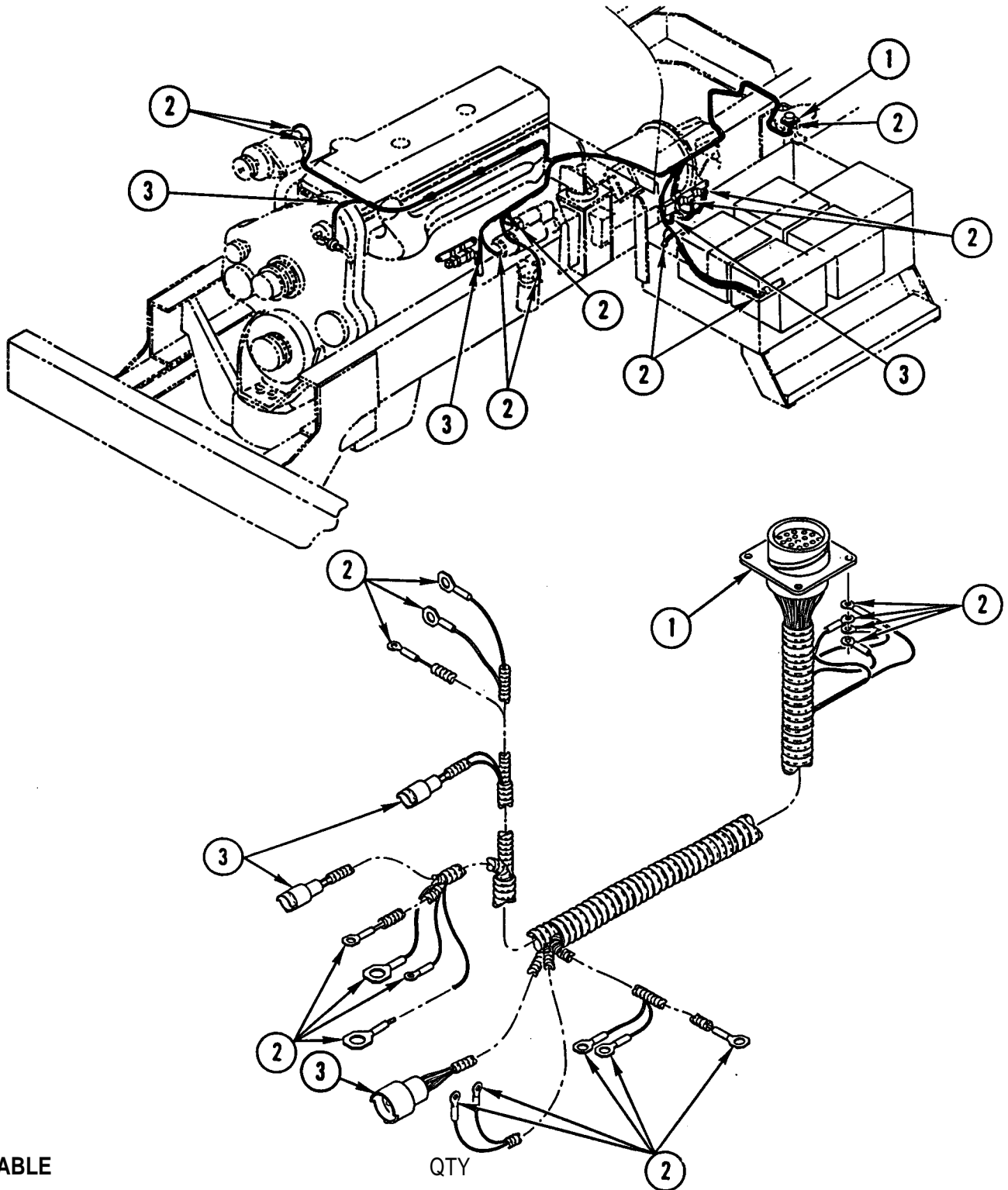

TABLE

- 1 Receptacle
- 2 Ring Terminal
- 3 2-Pin Connector

QTY

- 1
- 16
- 3

MAIN CAB WIRING HARNESS REPLACEMENT

This task covers: a. Removal b. Cleaning c. Inspection d. Installation

INITIAL SETUP

Tools and Special Equipment:

Shop Equipment, SC 4910-95-CL-A31
Tool Kit, SC 5180-90-CL-N05

Equipment Condition:

Reference	Condition Description
TM 9-2320-363-20	Batteries Disconnected

References:

TM 9-2320-363-20

REMOVAL

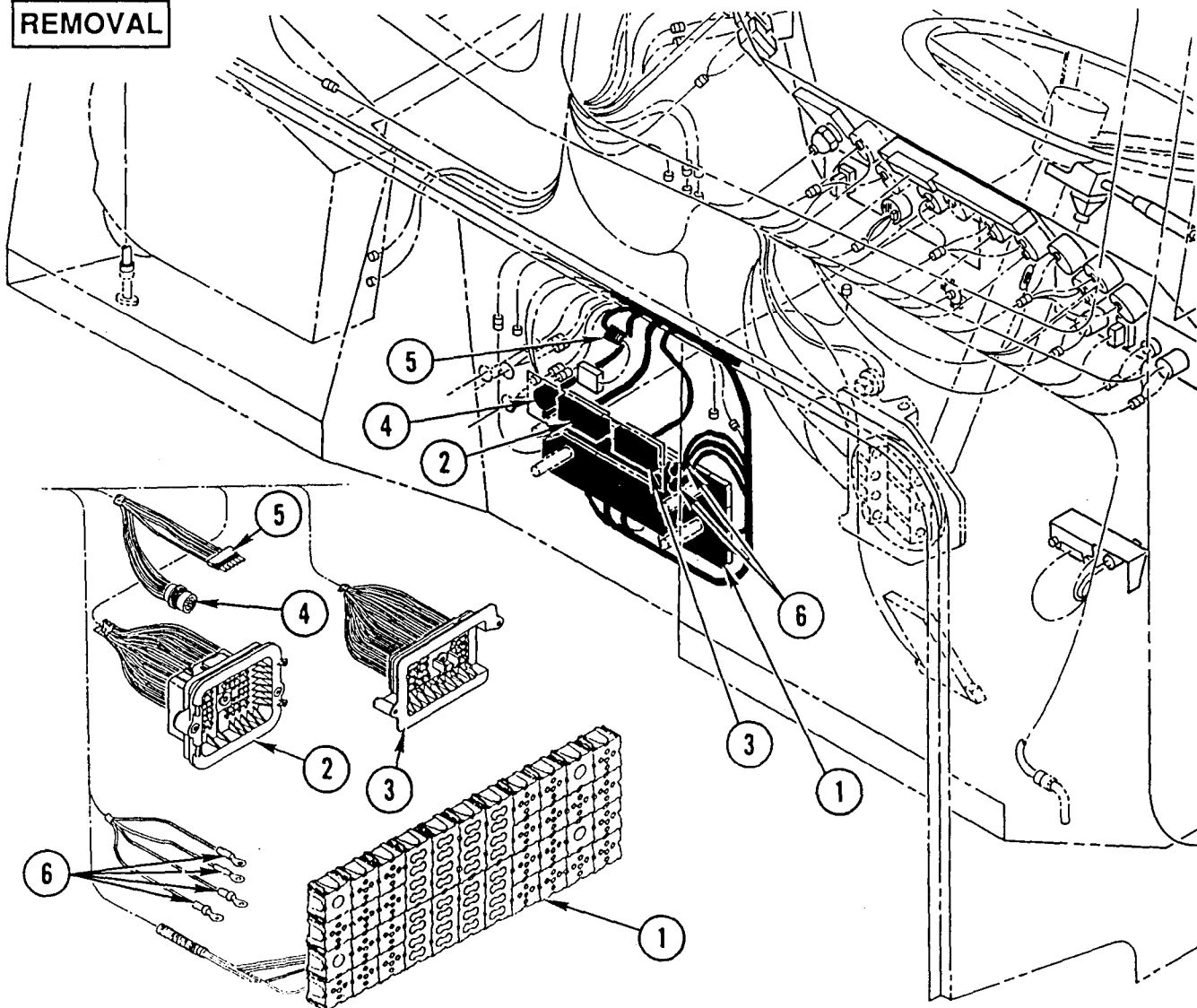

NOTE

- Wiring harness and leads are secured in place by clips, wire ties, cushion clamps, and screw terminals.
- Only remove hardware securing harness or lead to be removed.

1. DISCONNECT RELAY AND FUSE PANEL (1).
2. DISCONNECT 42-PIN CONNECTOR (2), 34-PIN CONNECTOR (3), 32-PIN CONNECTOR (4), 6-PIN SEALED CONNECTOR (5), AND FOUR RING TERMINALS (6).

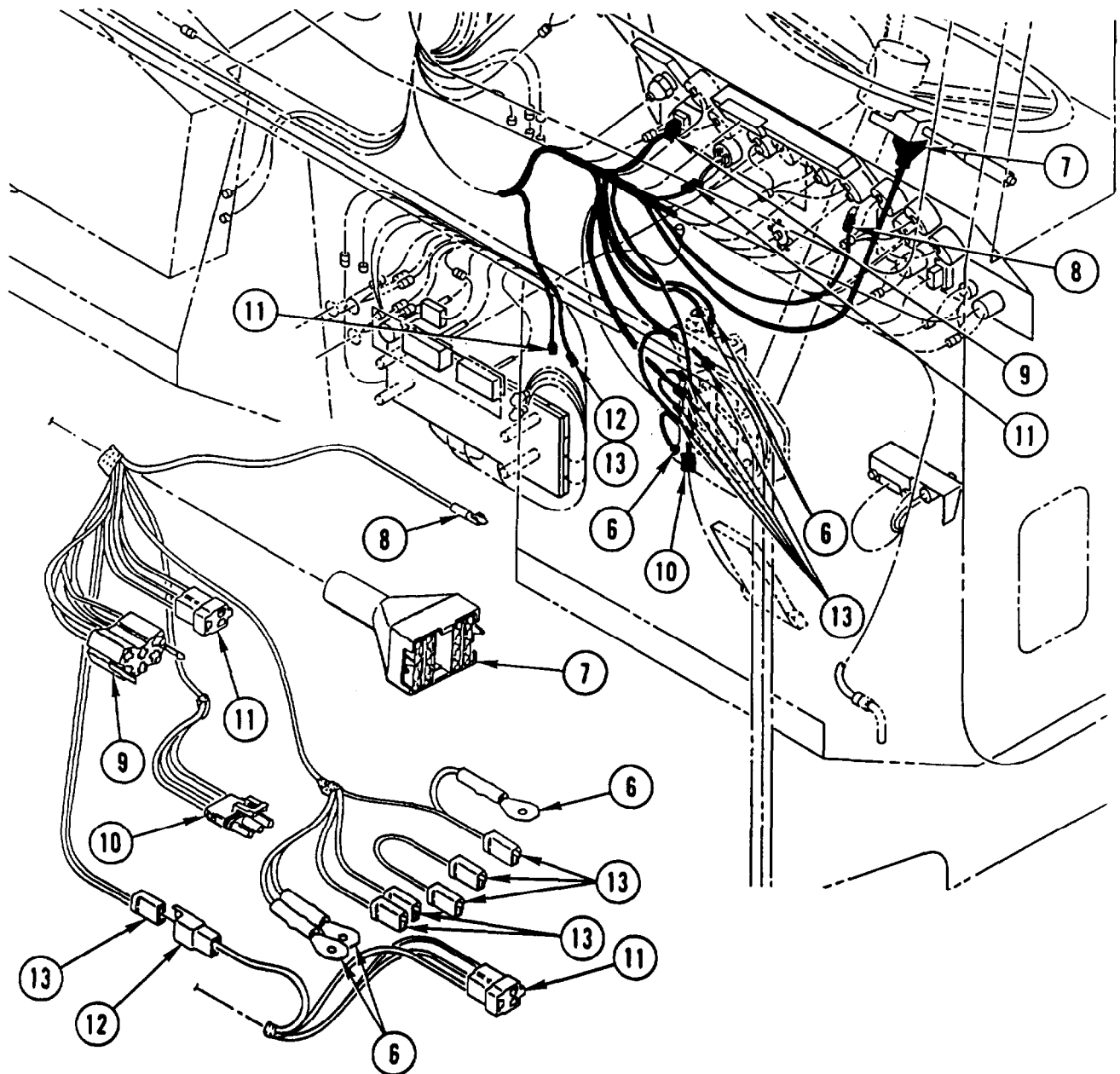

3. DISCONNECT THREE RING TERMINALS (6), 12-PIN CONNECTOR (7), FEMALE TERMINAL BLADE (8), 6-PIN FEMALE CONNECTOR (9), 3-PIN SEALED CONNECTOR (10), TWO 3-PIN FEMALE CONNECTORS (11), 1-PIN MALE CONNECTOR (12), AND SIX 1-PIN FEMALE CONNECTORS (13).

MAIN CAB WIRING HARNESS REPLACEMENT (CONT)

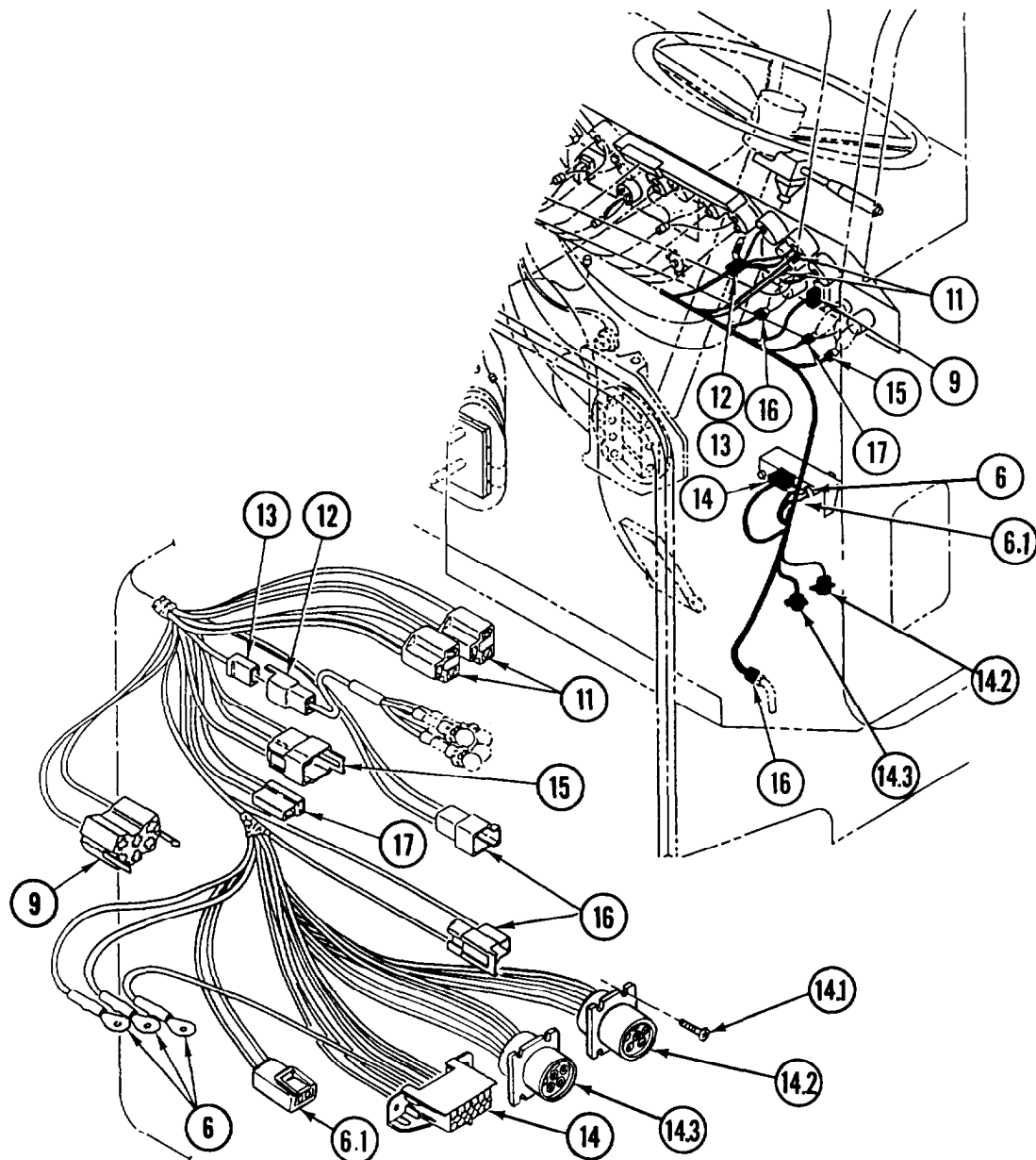

- 4 DISCONNECT THREE RING TERMINALS (6), 6-PIN FEMALE CONNECTOR (9), TWO 3-PIN FEMALE CONNECTORS (11), 1-PIN MALE CONNECTOR (12), 1-PIN FEMALE CONNECTOR (13), 12-PIN DIAGNOSTIC CONNECTOR (14), 3-PIN MALE CONNECTOR (15), TWO 2-PIN CONNECTORS (16), AND 2-PIN FEMALE CONNECTOR (17).

NOTE

Perform steps 4.1 and 4.2 for all except M915A2 and M916A1.

- 4.1 DISCONNECT 2-PIN MALE CONNECTOR (6.1).
- 4.2 REMOVE EIGHT SCREWS (14.1) AND REMOVE 6-PIN DIAGNOSTIC CONNECTOR (14.2) AND 9-PIN DATA LOGGER CONNECTOR (14.3).

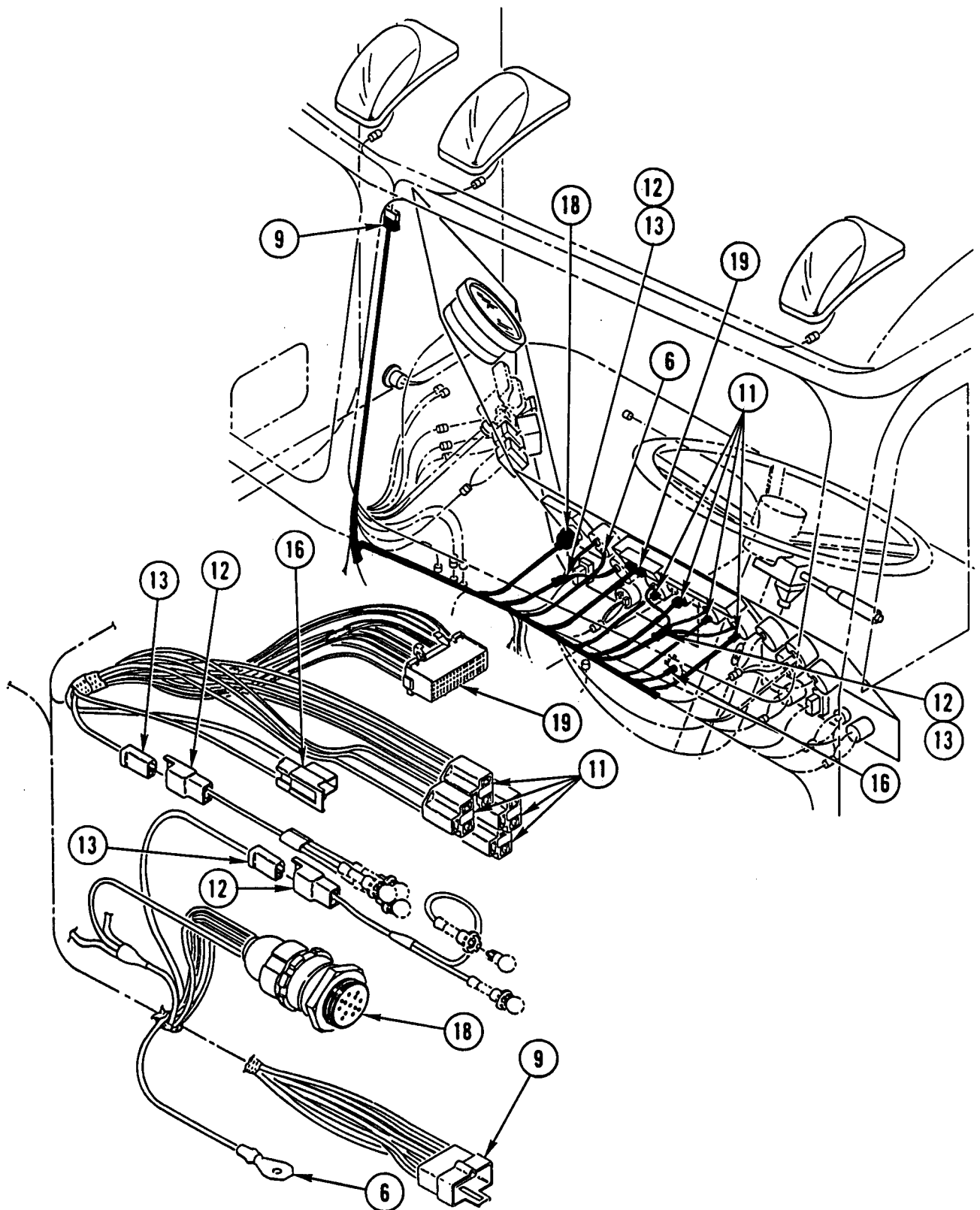

5. DISCONNECT RING TERMINAL (6), 6-PIN FEMALE CONNECTOR (9), FOUR 3-PIN FEMALE CONNECTORS (11), TWO 1-PIN MALE CONNECTORS (12), TWO 1-PIN FEMALE CONNECTOR (13), 2-PIN MALE CONNECTOR (16), 12-PIN LIGHT SWITCH CONNECTOR (18), AND 32-PIN CONNECTOR (19).

MAIN CAB WIRING HARNESS REPLACEMENT (CONT)

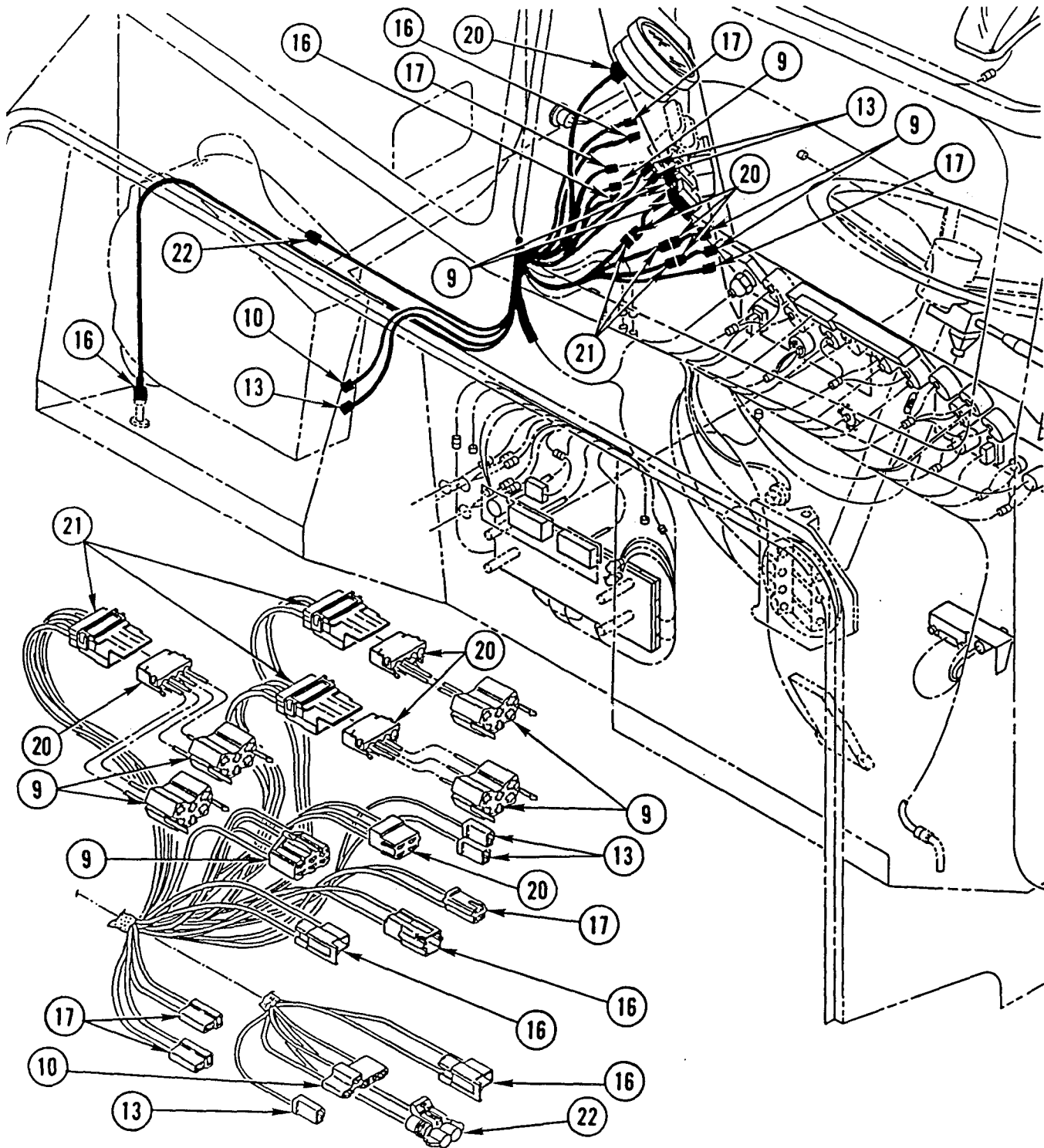

6. DISCONNECT FIVE 6-PIN FEMALE CONNECTORS (9), 3-PIN SEALED CONNECTOR (10), THREE 1-PIN FEMALE CONNECTORS (13), THREE 2-PIN MALE CONNECTORS (16), THREE 2-PIN FEMALE CONNECTORS (17), FOUR 4-PIN MALE CONNECTORS (20), THREE 4-PIN FEMALE CONNECTORS (21), AND 2-PIN SEALED CONNECTOR (22).

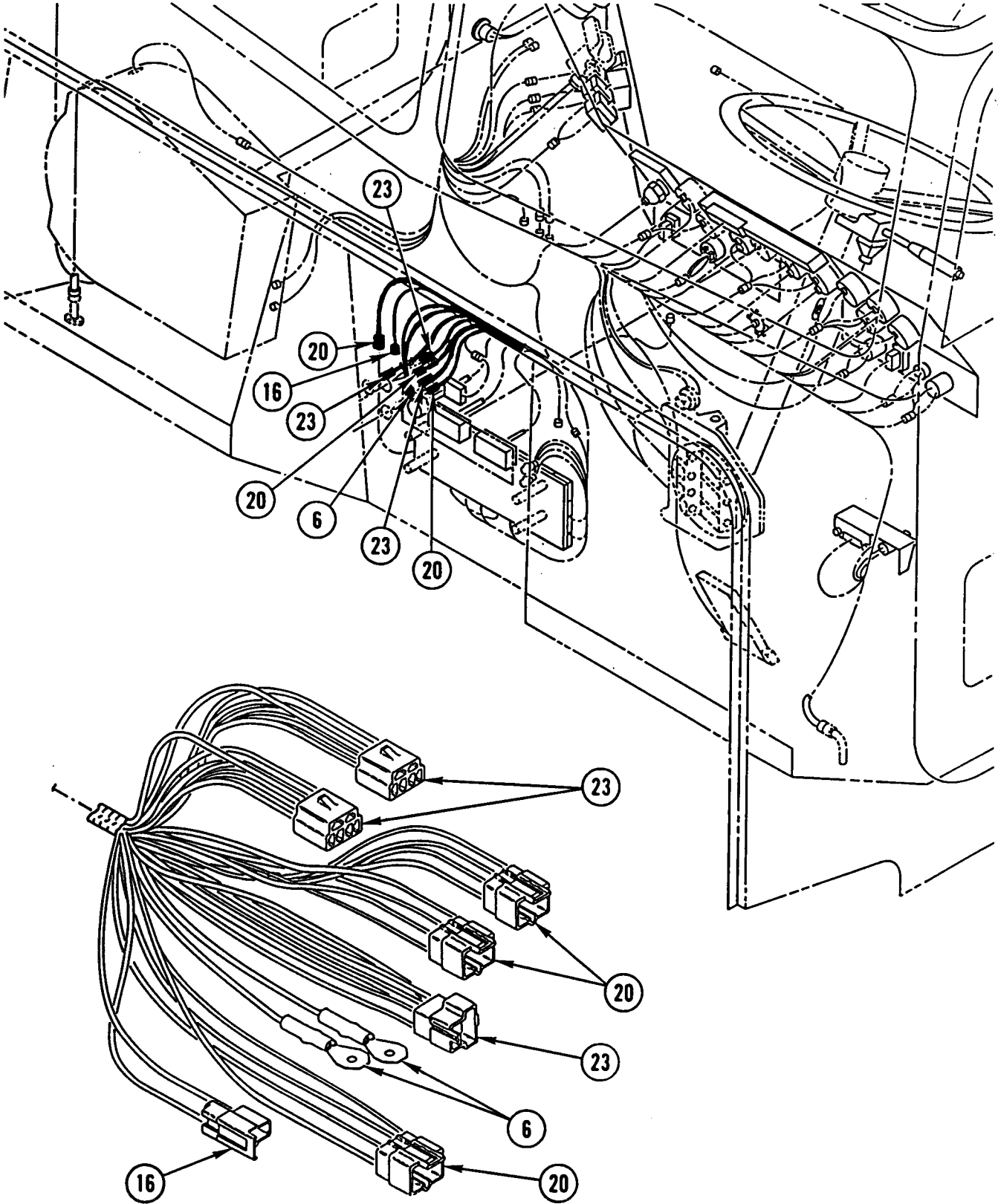

7. USCONNECT TWO RING TERMINALS (6), 2-PIN MALE CONNECTOR (16), THREE 4-PIN MALE CONNECTORS (20), AND THREE 6-PIN MALE CONNECTORS (23).

MAIN CAB WIRING HARNESS REPLACEMENT (CONT)

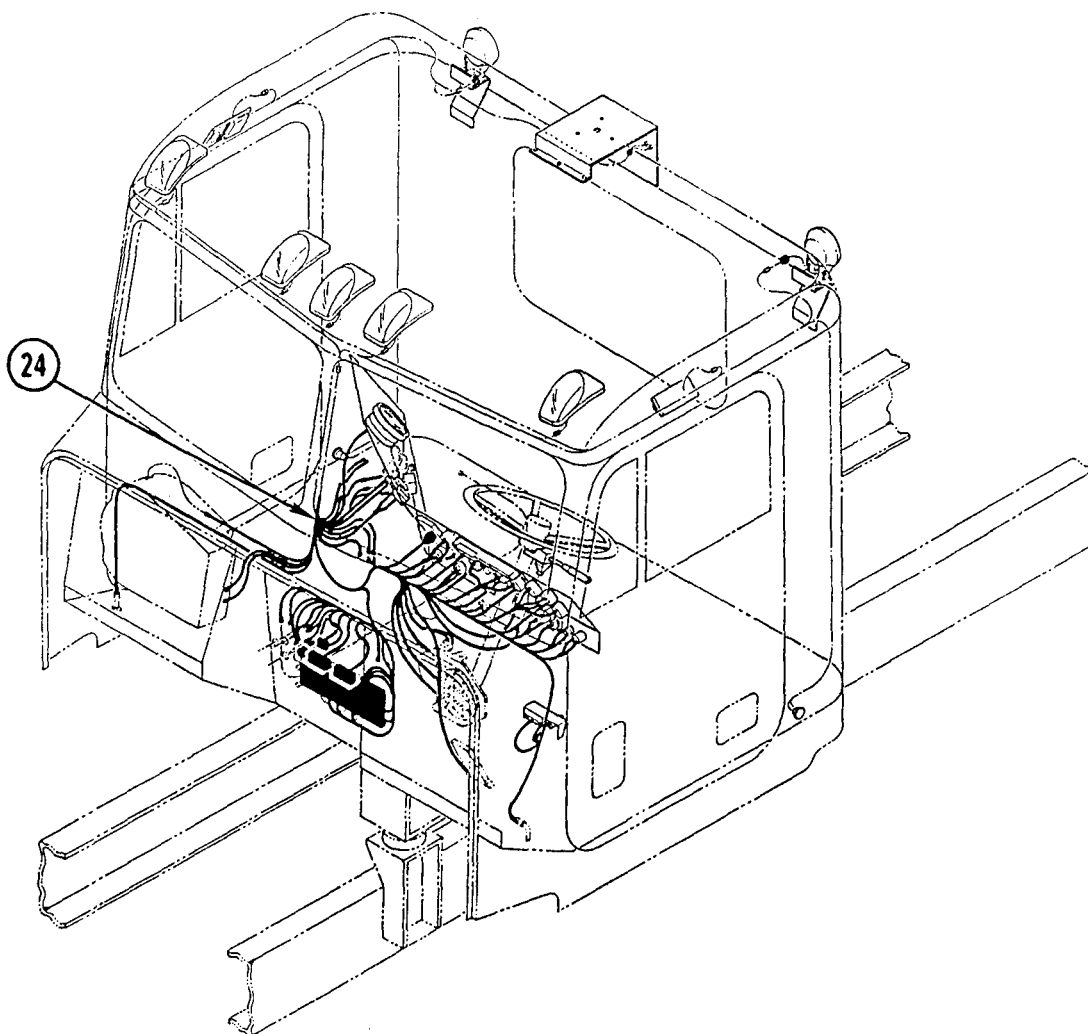

8. REMOVE MAIN CAB WIRING HARNESS (24).

CLEANING

Use general cleaning methods to clean all parts (page 2-30).

INSPECTION

Inspect all parts for wear or damage.

INSTALLATION

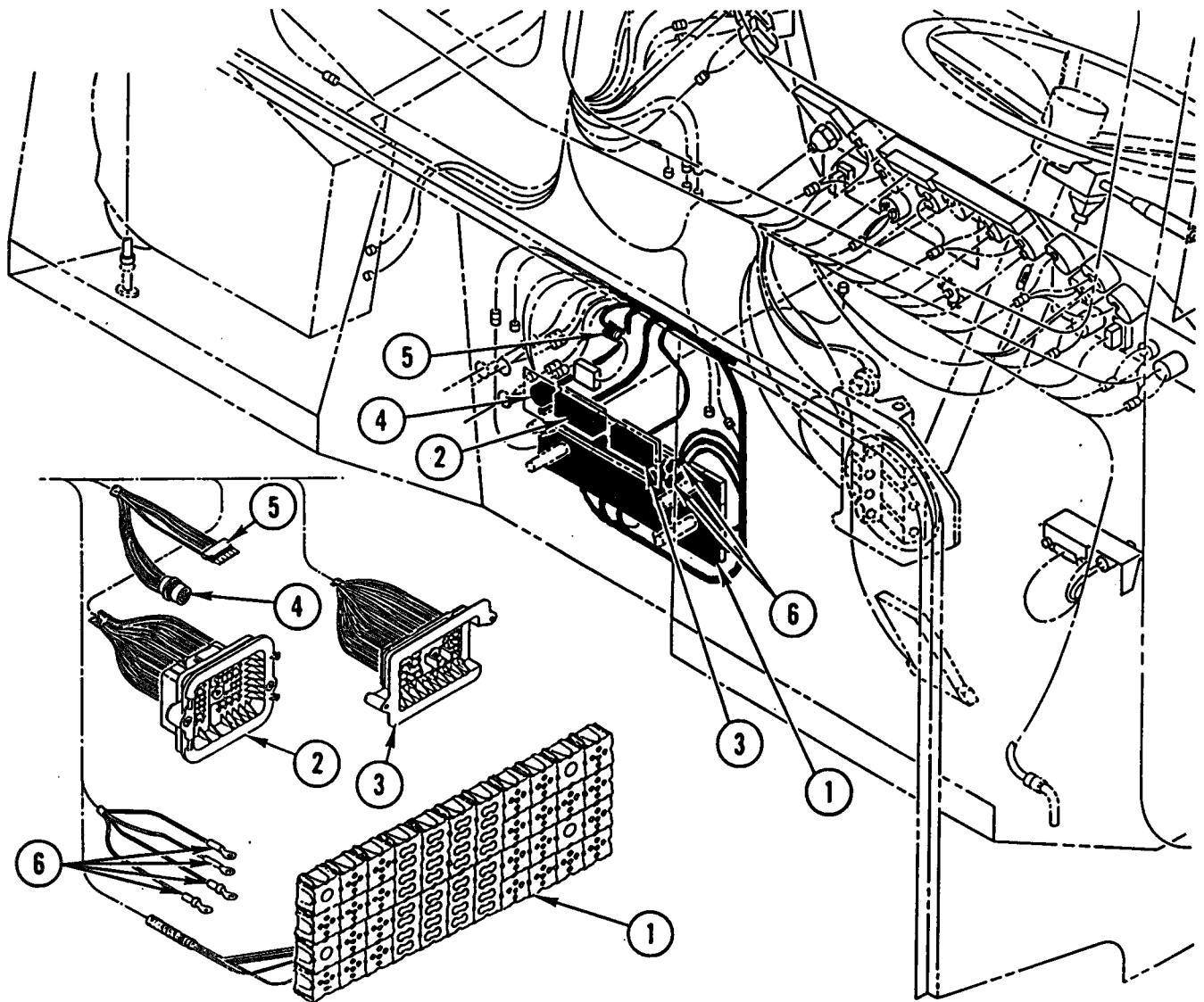

NOTE

- Wiring harness and leads are secured in place by clips, wire ties, cushion clamps, and screw terminals.
- Make sure wiring harness is secure and all hardware is tight.

1. CONNECT RELAY AND FUSE PANEL (1),
2. CONNECT 42-PIN CONNECTOR (2), 34-PIN CONNECTOR (3), 32-PIN CONNECTOR (4), 6-PIN SEALED CONNECTOR (5), AND FOUR RING TERMINALS (6).

MAIN CAB WIRING HARNESS REPLACEMENT (CONT)

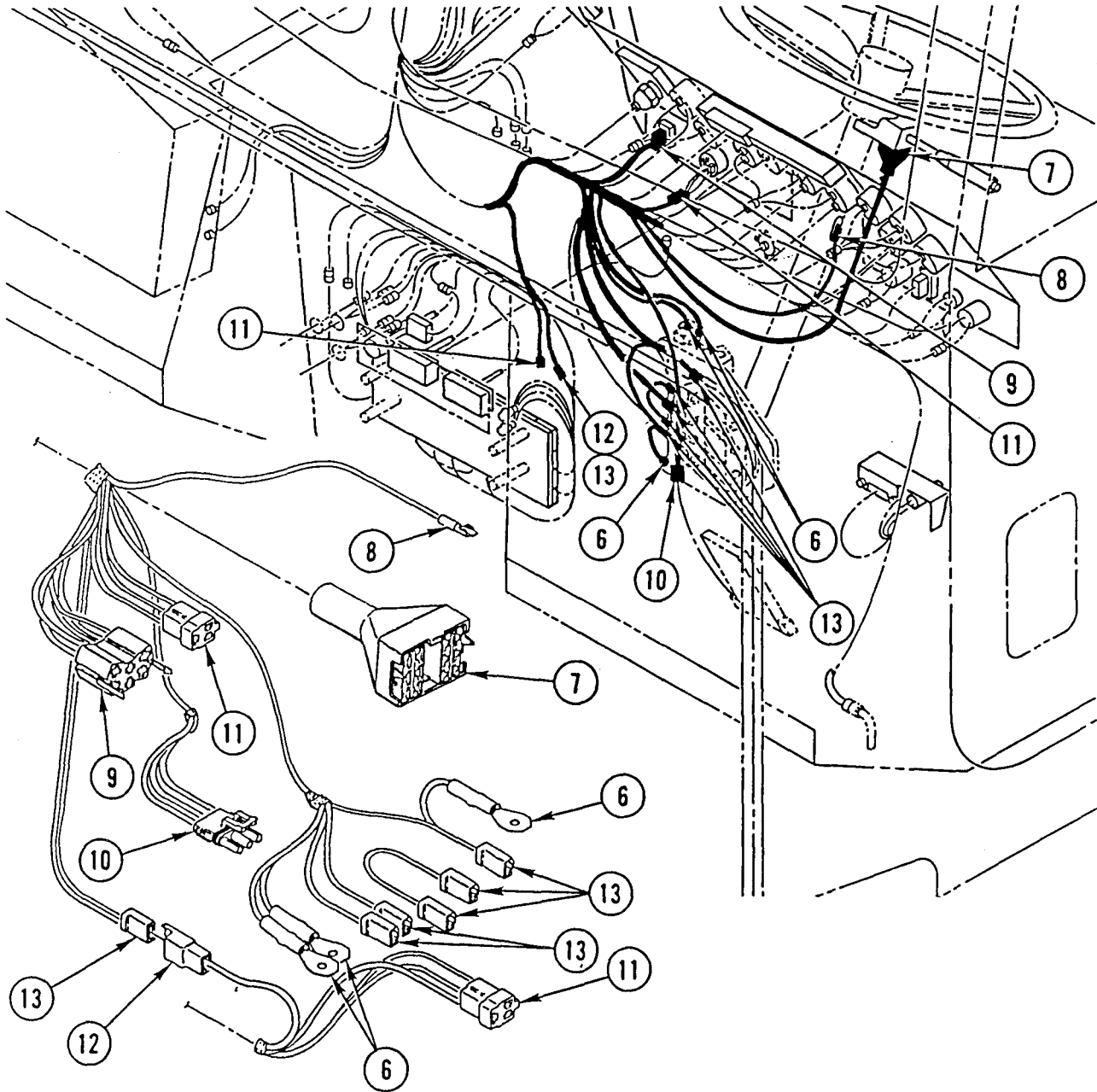

3. CONNECT THREE RING TERMINALS (6), 12-PIN CONNECTOR (7), FEMALE TERMINAL BLADE (8), 6-PIN FEMALE CONNECTOR (9), 3-PIN SEALED CONNECTOR (10), TWO 3-PIN FEMALE CONNECTORS (11), 1-PIN MALE CONNECTOR (12), AND SIX 1-PIN FEMALE CONNECTORS (13).

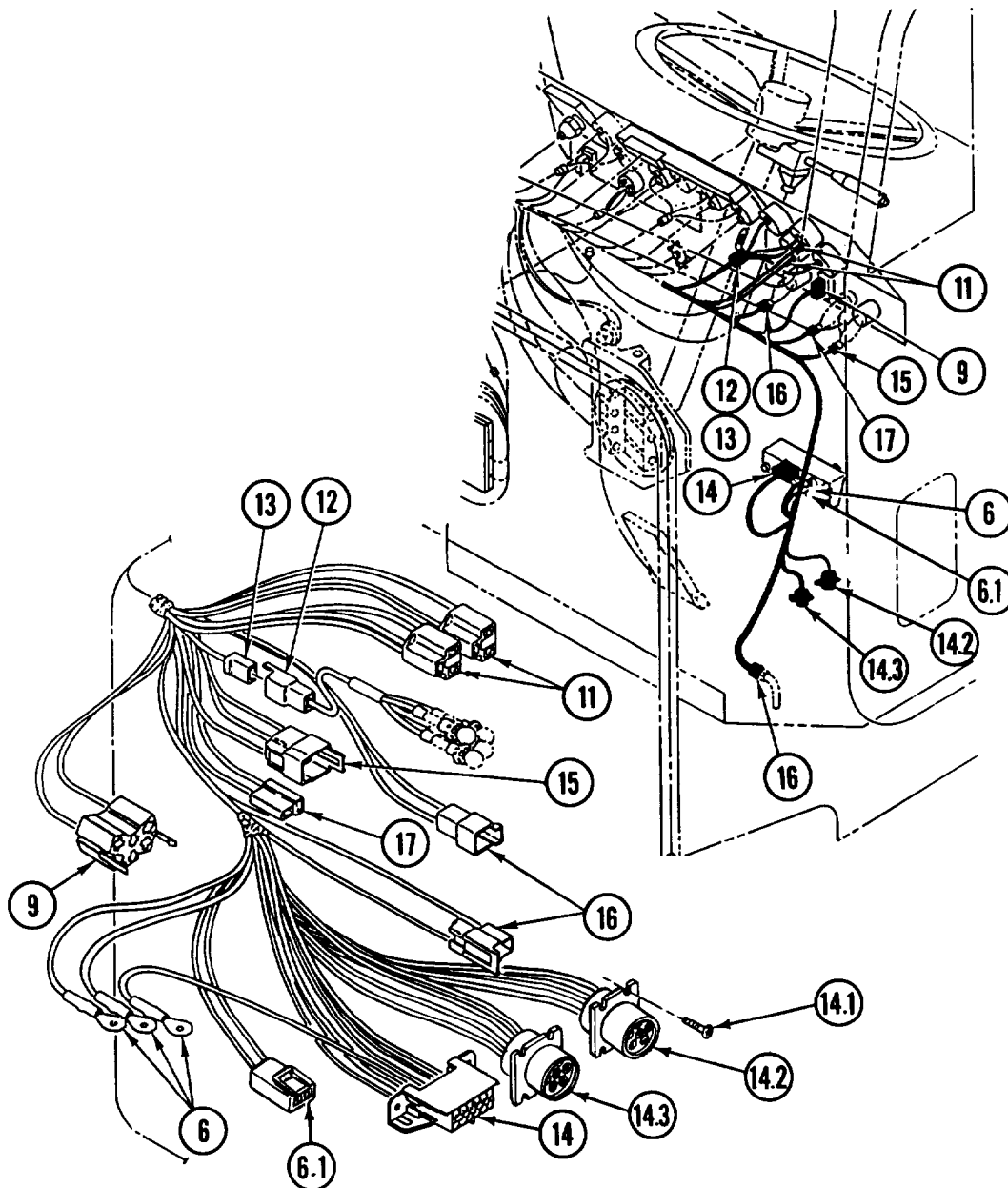

NOTE

Perform steps 3.1 and 3.2 for all except M915A2 and M916A1.

- 3.1 INSTALL 9-PIN DATA LOGGER CONNECTOR (14.3) AND 6-PIN DIAGNOSTIC CONNECTOR (14.2) WITH EIGHT SCREWS (14.1).
- 3.2 CONNECT 2-PIN MALE CONNECTOR (6.1).
4. CONNECT THREE RING TERMINALS (6), 6-PIN FEMALE CONNECTOR (9), TWO 3-PIN FEMALE CONNECTORS (11), 1-PIN MALE CONNECTOR (12), 1-PIN FEMALE CONNECTOR (13), 12-PIN DIAGNOSTIC CONNECTOR (14), 3-PIN MALE CONNECTOR (15), TWO 2-PIN CONNECTORS (16), AND 2-PIN FEMALE CONNECTOR (17).

MAIN CAB WIRING HARNESS REPLACEMENT (CONT)

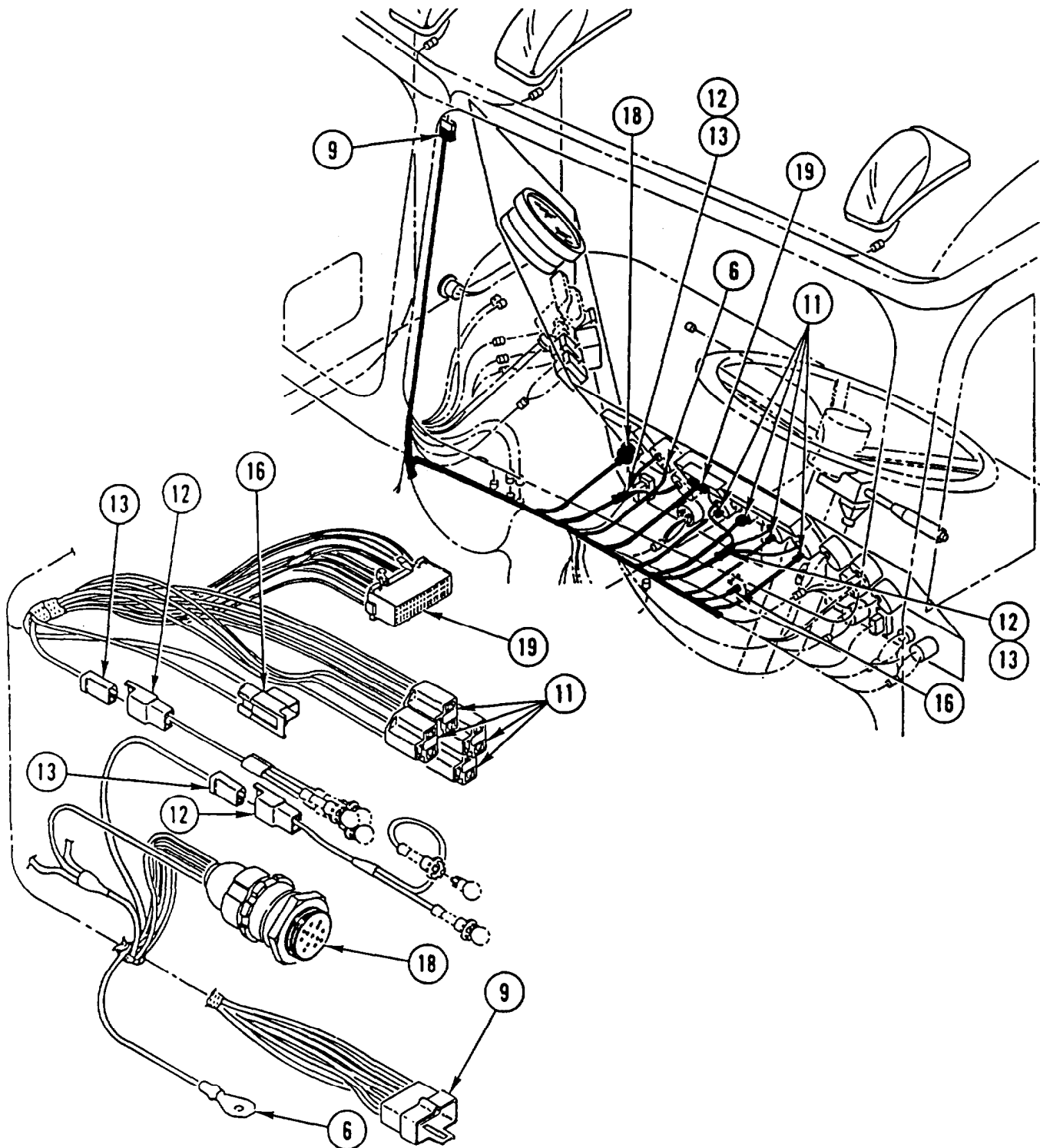

5. CONNECT RING TERMINAL (6), 6-PIN FEMALE CONNECTOR (9), FOUR 3-PIN FEMALE CONNECTORS (11), TWO 1-PIN MALE CONNECTORS (12), TWO 1-PIN FEMALE CONNECTOR (13), 2-PIN MALE CONNECTOR (16), 12-PIN LIGHT SWITCH CONNECTOR (18), AND 32-PIN CONNECTOR (19).

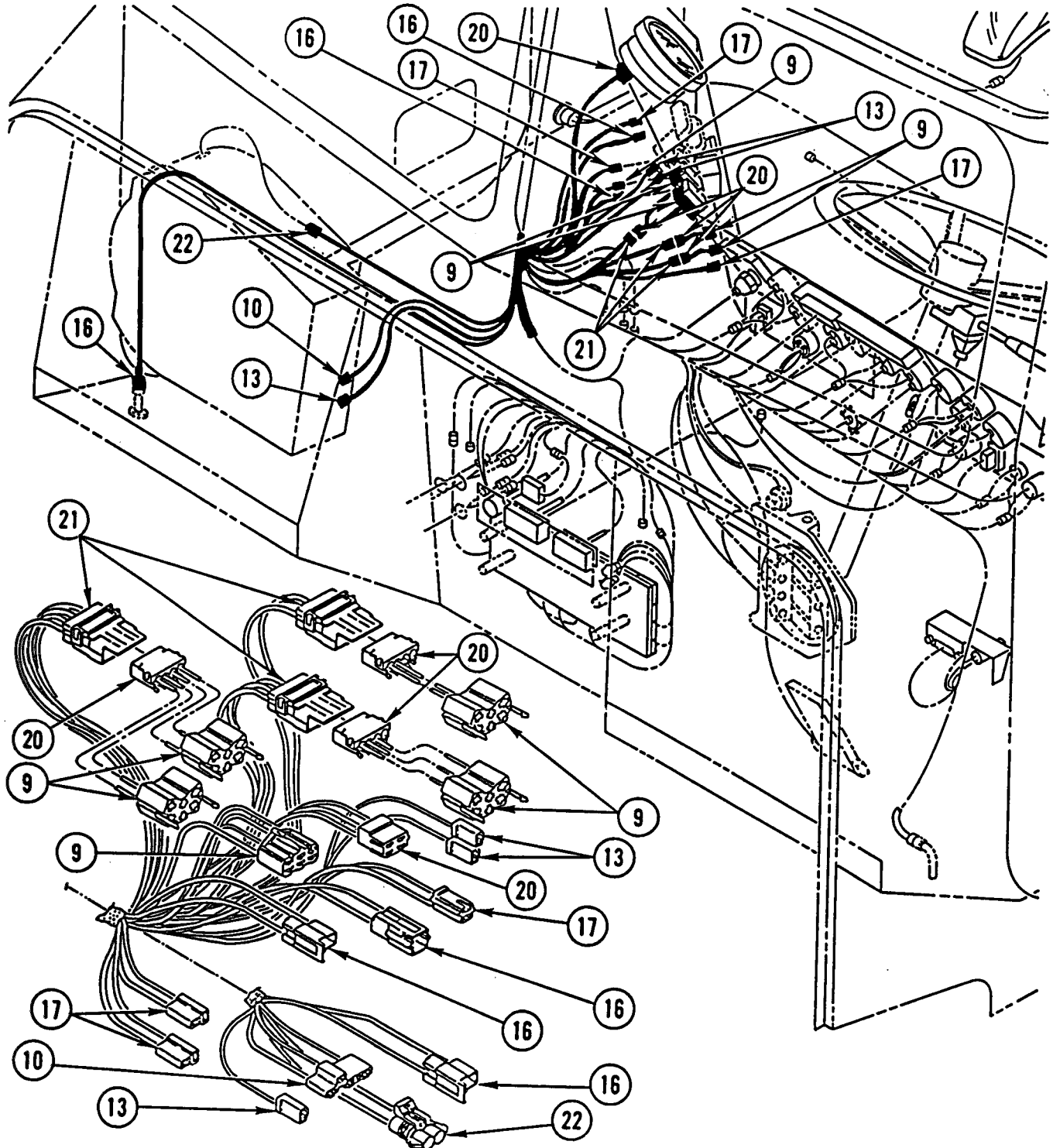

6. CONNECT FIVE 6-PIN FEMALE CONNECTORS (9), 3-PIN SEALED CONNECTOR (10), THREE 1-PIN FEMALE CONNECTORS (13), THREE 2-PIN MALE CONNECTORS (16), THREE 2-PIN FEMALE CONNECTORS (17), FOUR 4-PIN MALE CONNECTORS (20), THREE 4-PIN FEMALE CONNECTORS (21), AND 2-PIN SEALED CONNECTOR (22).

MAIN CAB WIRING HARNESS REPLACEMENT (CONT)

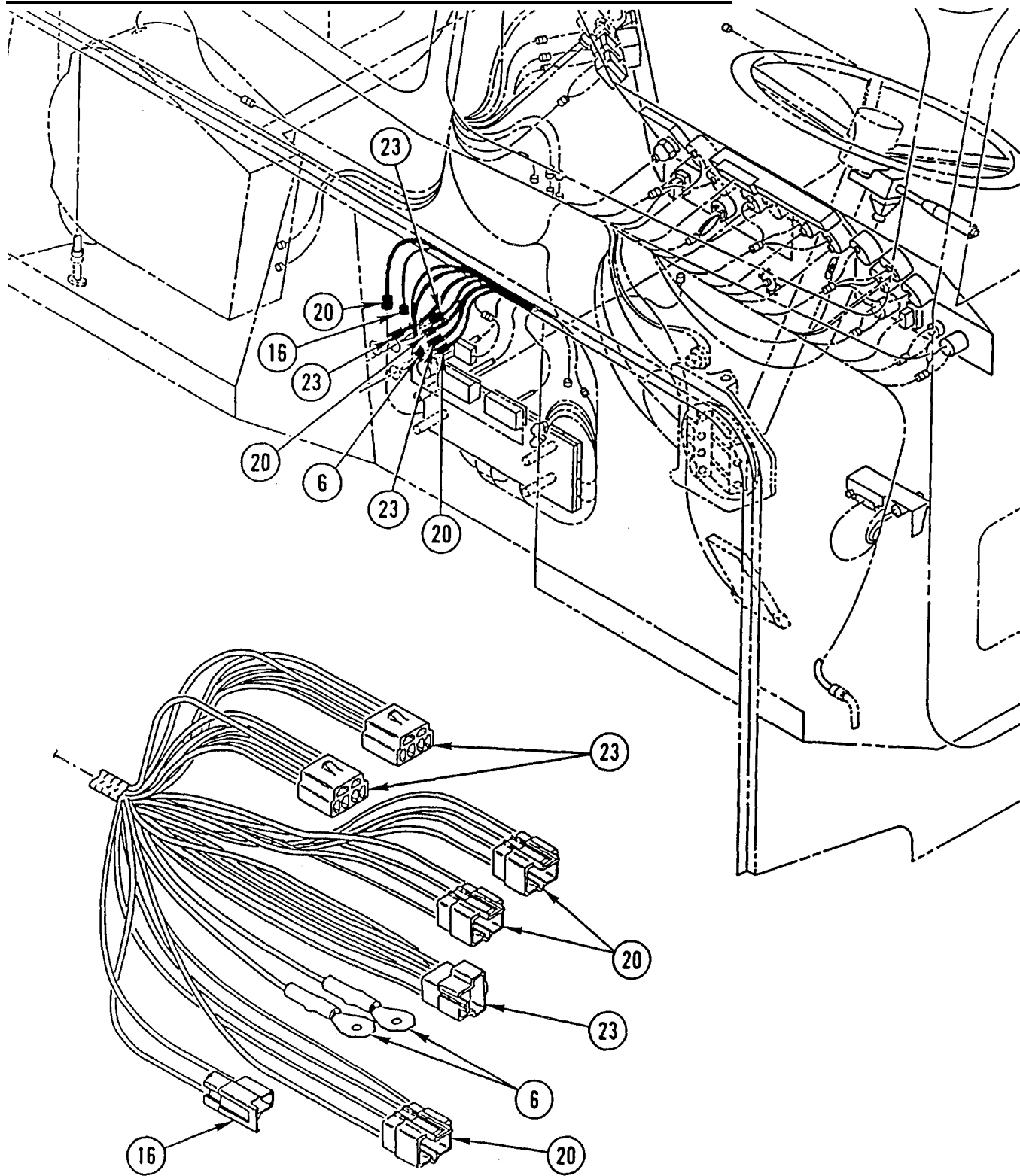

7. CONNECT TWO RING TERMINALS (6), 2-PIN MALE CONNECTOR (16), THREE 4-PIN MALE CONNECTORS (20), AND THREE 6-PIN MALE CONNECTORS (23).

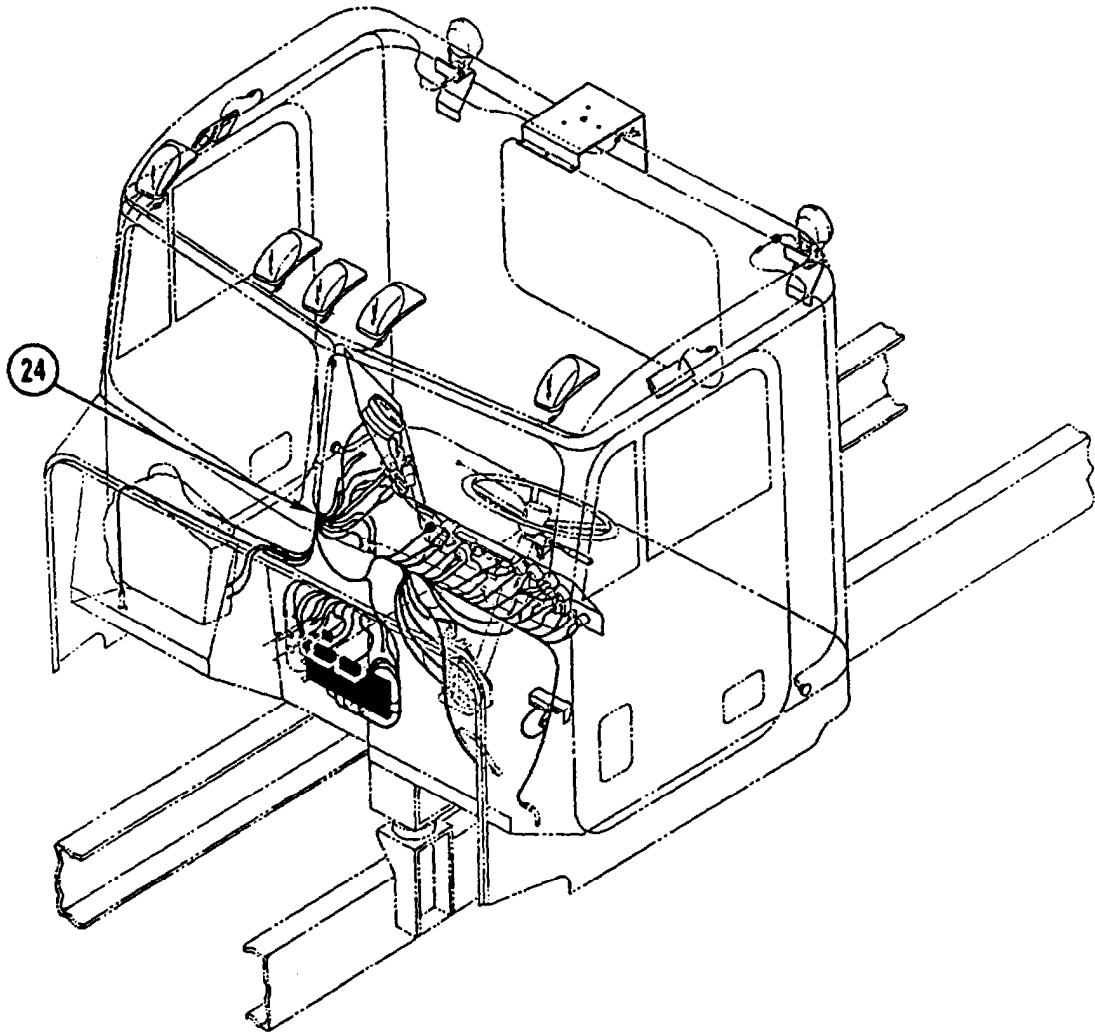

8. SECURE MAIN CAB WIRING HARNESS (24).

NOTE

Follow-on Maintenance:

Connect batteries (TM 9-2320-363-20).

OVERHEAD CAB WIRING HARNESS REPLACEMENT

This task covers: a. Removal b. Cleaning c. Inspection d. Installation

INITIAL SETUP

Tools and Special Equipment:

Shop Equipment, SC 4910-95-CL-A31
Tool Kit, SC 5180-90-CL-N05

References:

TM 9-2320-363-20

Equipment Condition:

Reference	Condition	Description
-----------	-----------	-------------

TM 9-2320-363-20	Head Liners	Removed
------------------	-------------	---------

TM 9-2320-363-20	Batteries	Disconnected
------------------	-----------	--------------

REMOVAL

NOTE

- Wiring harness and leads are secured in place by clips and screw terminals.
- Only remove hardware securing harness or lead to be removed.
- M917A1 and M917A1 w/MCS have no utility lights. Item 4 is not included in M917A1 and M917A1 w/MCS wiring harness.

DISCONNECT AND REMOVE OVERHEAD CAB WIRING HARNESS USING ILLUSTRATION AND TABLE AS A GUIDE.

CLEANING

Use general cleaning methods to clean all parts (page 2-30).

INSPECTION

Inspect all parts for wear or damage.

NOTE

- Wiring harness and leads are secured in place by clips and screw terminals.
- Make sure harness is secure and all hardware is tight.
- M917A1 and M917A1 w/MCS have no utility lights. Item 4 is not included in M917A1 and M917A1 w/MCS wiring harness.

INSTALL AND CONNECT OVERHEAD CAB WIRING HARNESS USING ILLUSTRATION AND TABLE AS A GUIDE.

NOTE

Follow-on Maintenance:

Connect batteries (TM 9-2320-363-20).

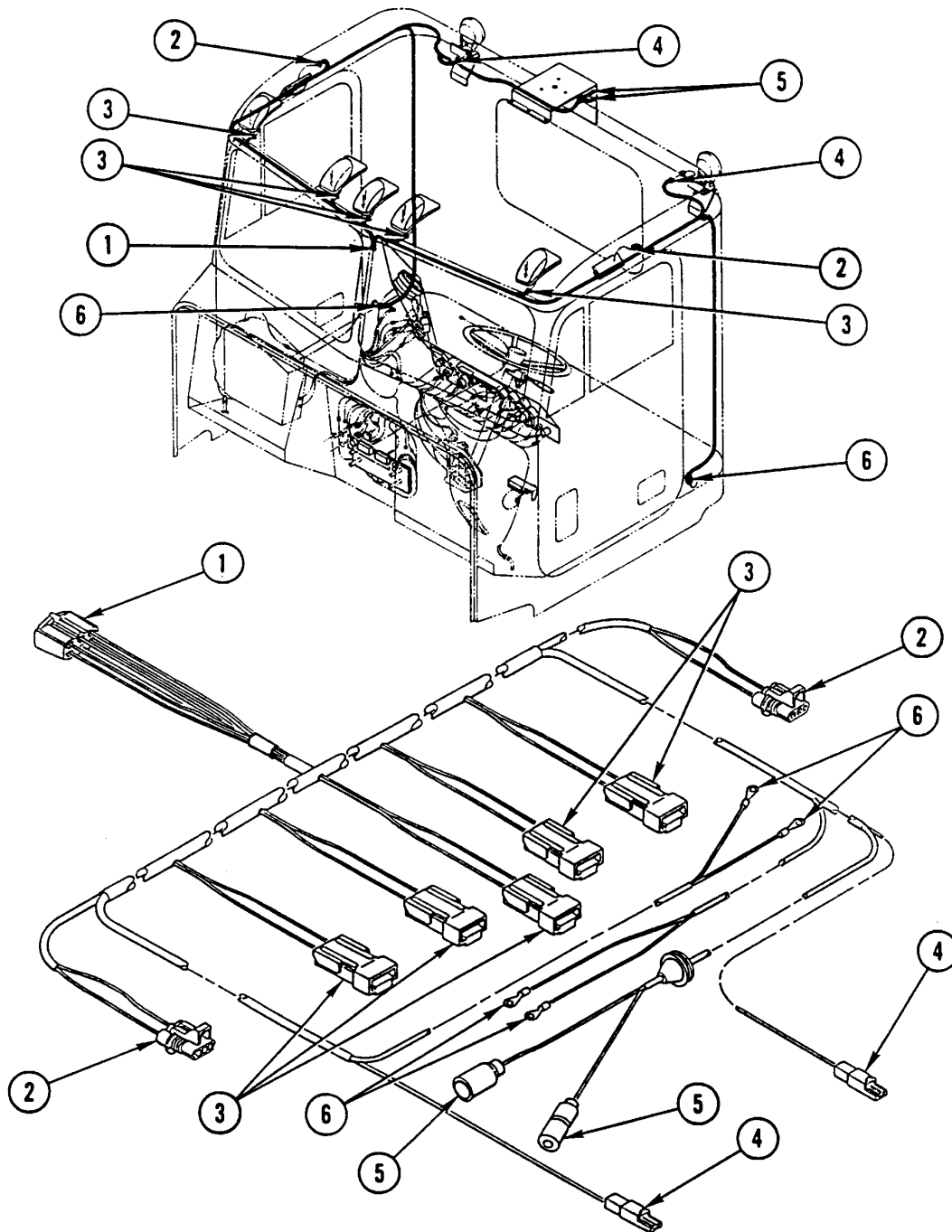

TABLE

QTY

1	6-Pin Connector	1
2	3-Pin Connector	2
3	2-Pin Connector	5
* 4	1-Pin Connector	2
5	Cable Connector	2
6	Ring Terminal	4

* All except M917A1 and M917A1 w/MCS

CAB FLOOR ANTI-LOCK BRAKE SYSTEM (ABS) WIRING HARNESS REPLACEMENT (M915A2 AND M916A1)

This task covers: a. Removal b. Cleaning c. Inspection d. Installation

INITIAL SETUP

Tools and Special Equipment:

Shop Equipment, SC 4910-95-CL-A31
Tool Kit, SC 5180-90-CL-N05

Equipment Condition:

Reference	Condition Description
TM 9-2320-363-20	Batteries Disconnected

References:

TM 9-2320-363-20

REMOVAL

NOTE

- Wiring harness and leads are secured in place by wire ties, cushion clamps, and screw terminals.
- Only remove hardware securing harness or lead to be removed.

DISCONNECT AND REMOVE CAB FLOOR ABS WIRING HARNESS USING ILLUSTRATION AND TABLE AS A GUIDE.

CLEANING

Use general cleaning methods to clean all parts (page 2-30).

INSPECTION

Inspect all parts for wear or damage.

INSTALLATIO

NOTE

- Wiring harness and leads are secured in place by wire ties, cushion clamps, and screw terminals.
- Make sure harness is secure and all hardware is tight.

INSTALL AND CONNECT CAB FLOOR WIRING HARNESS USING ILLUSTRATION AND TABLE AS A GUIDE.

NOTE

Follow-on Maintenance:

Connect batteries (TM 9-2320-363-20).

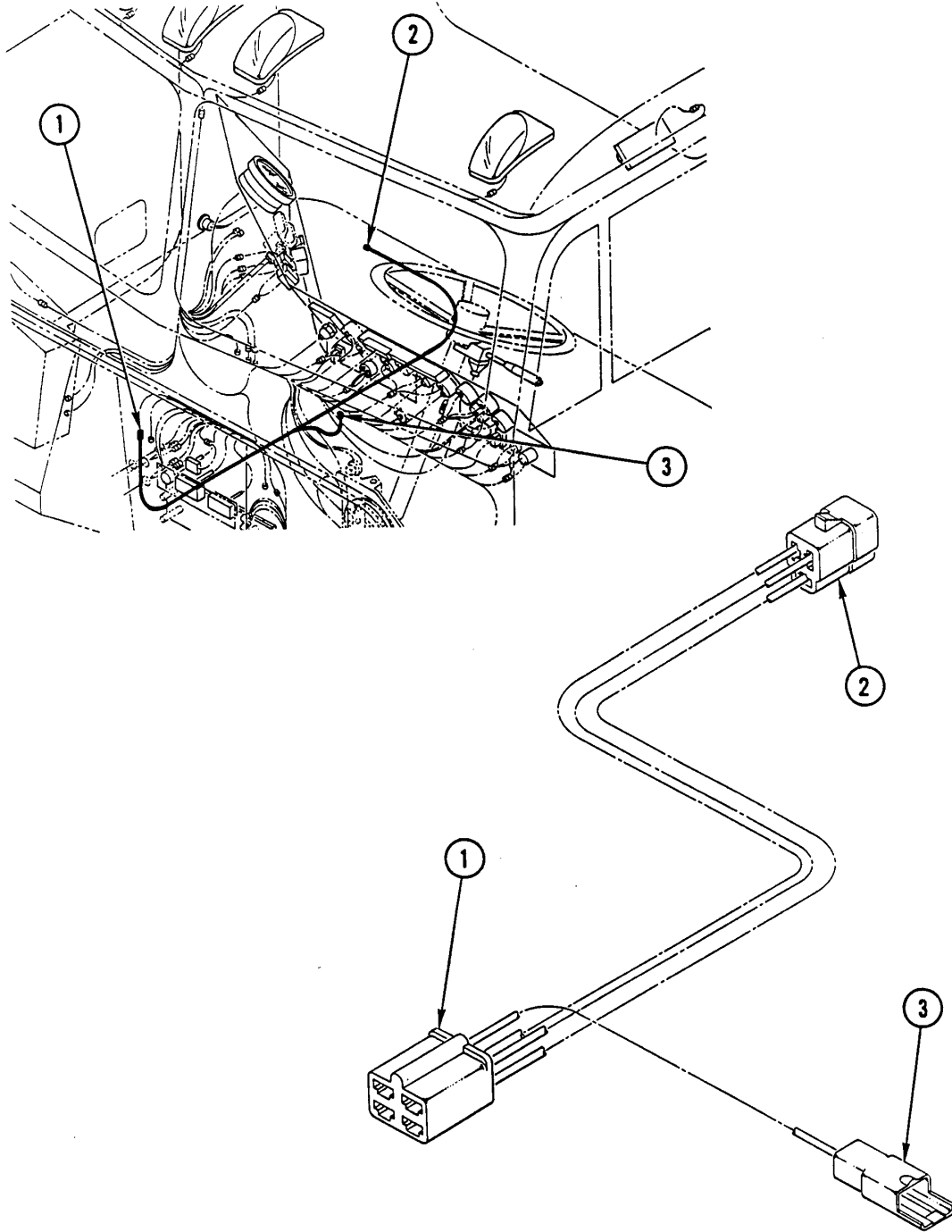

TABLE

QTY

1	4-Pin Female Connector	1
2	3-Pin Female Connector	1
3	1-Pin Female Connector	1

CAB FLOOR ANTI-LOCK BRAKE SYSTEM (ABS) WIRING HARNESS REPLACEMENT (M915A2 AND M916A1)

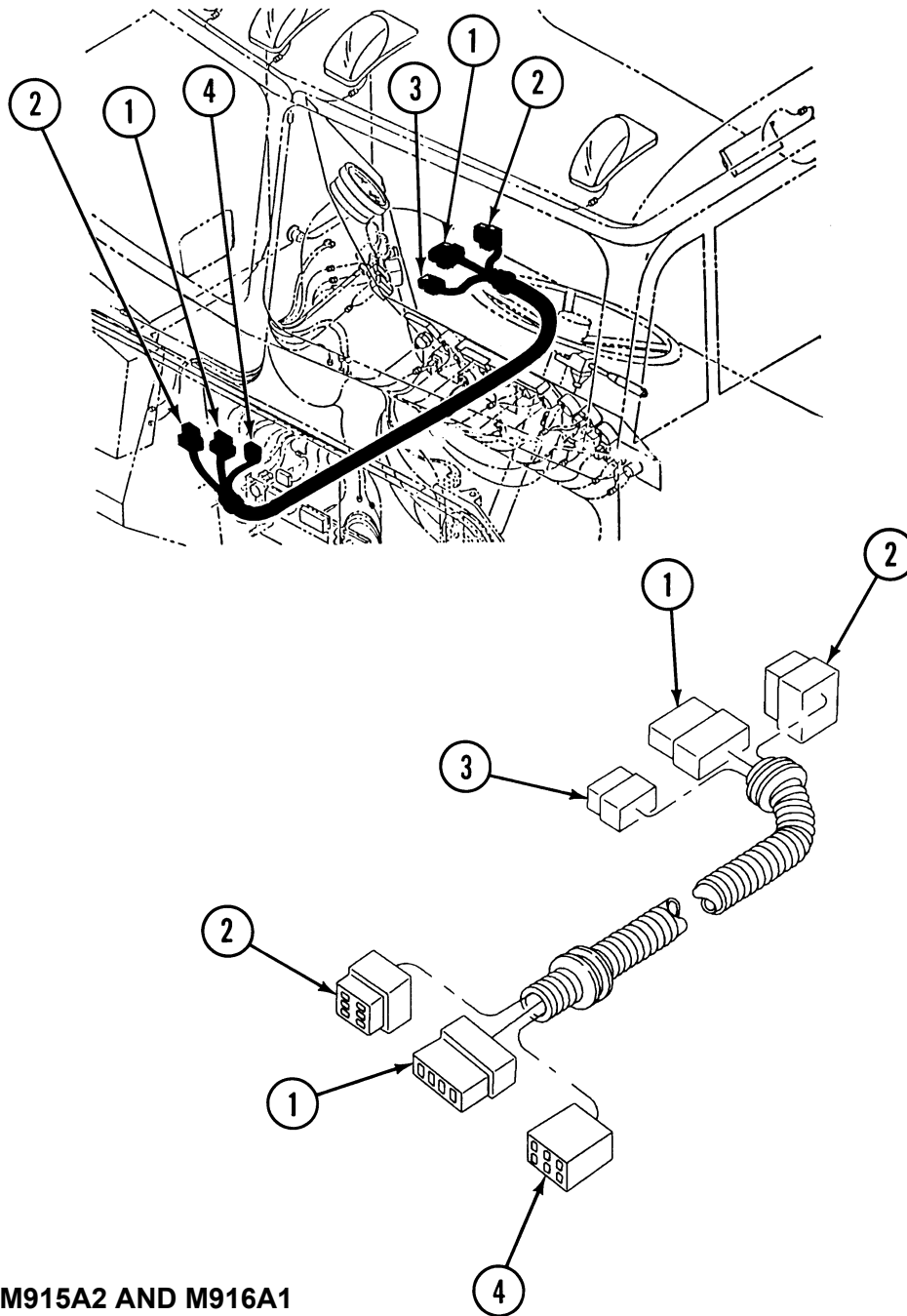

ALL EXCEPT M915A2 AND M916A1

TABLE		QTY
1	4-Pin Male Connector	1
2	6-Pin Male Connector	1
3	6-Pin Female Connector	1
4	6-Pin Female Connector	1

FUEL HOSES AND CLAMPS REPLACEMENT (CONT)

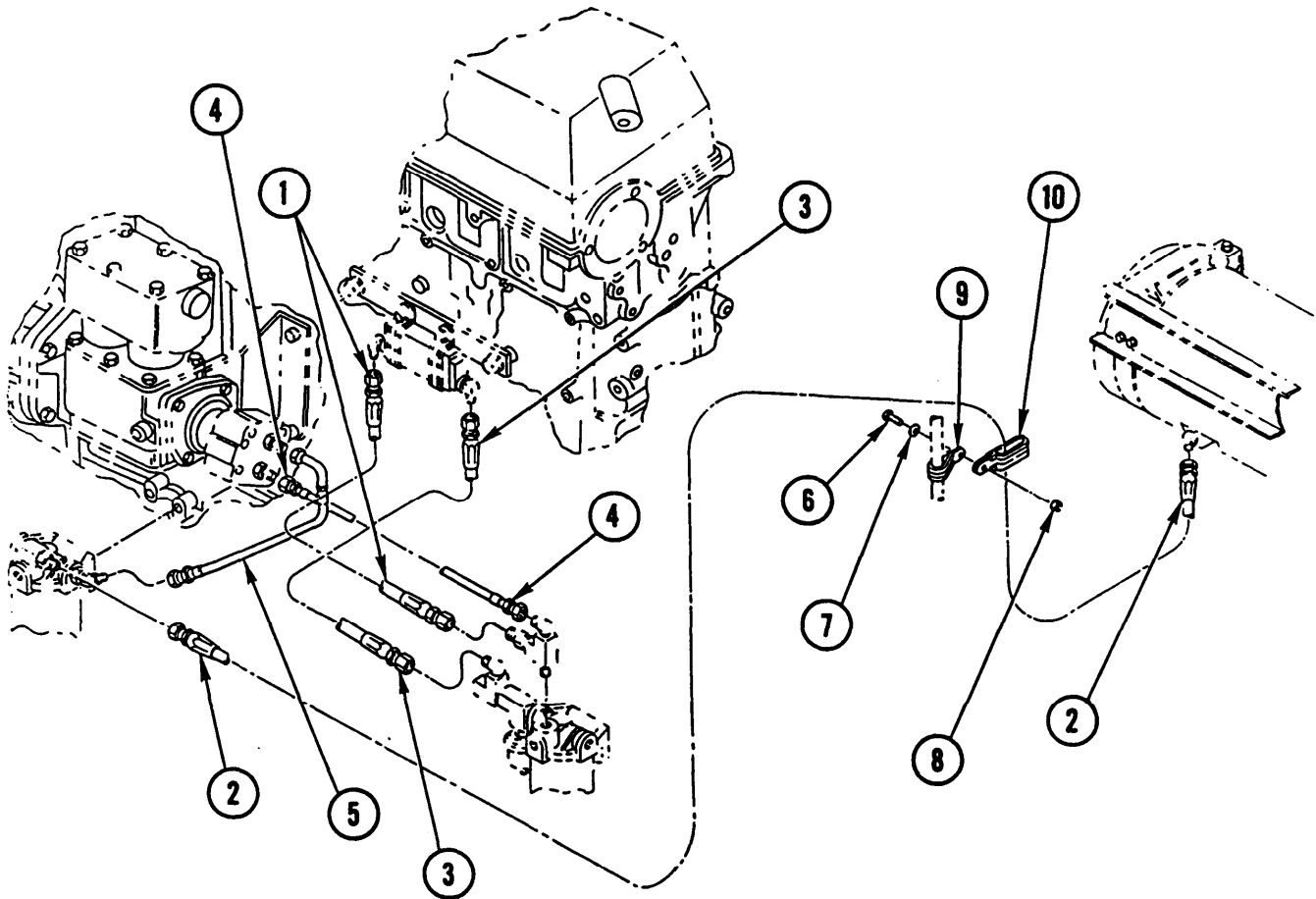

LEGEND

- 1 HOSE ASSEMBLY
- 2 HOSE ASSEMBLY
- 3 HOSE ASSEMBLY
- 4 HOSE ASSEMBLY
- 5 HOSE ASSEMBLY
- 6 SCREW
- 7 WASHER
- 8 LOCK NUT
- 9 CLAMP
- 10 CLAMP

SWITCH PANEL WIRING HARNESSES REPLACEMENT

This task covers: a. Removal b. Cleaning c. Inspection d. Installation

INITIAL SETUP

Tools and Special Equipment:

Shop Equipment, SC 4910-95-CL-A31
Tool Kit, SC 5180-90-CL-N05

References:

TM 9-2320-363-20

Equipment Condition:

Reference	Condition Description
TM 9-2320-363-20	Batteries Disconnected

REMOVAL

NOTE

- Wiring harness and leads are secured in place by clips, wire ties, cushion clamps, and screw terminals.
- Only remove hardware securing harness or lead to be removed.

DISCONNECT AND REMOVE SWITCH PANEL WIRING HARNESSSES USING ILLUSTRATION AND TABLE AS A GUIDE.

CLEANING

Use general cleaning methods to clean all parts (page 2-30).

INSPECTION

Inspect all parts for wear or damage.

INSTALLATION

NOTE

- Wiring harness and leads are secured in place by clips, wire ties, cushion clamps, and screw terminals.
- Make sure harness is secure and all hardware is tight.

INSTALL AND CONNECT SWITCH PANEL WIRING HARNESSSES USING ILLUSTRATION AND TABLE AS A GUIDE.

NOTE

Follow-on Maintenance:

Connect batteries (TM 9-2320-363-20).

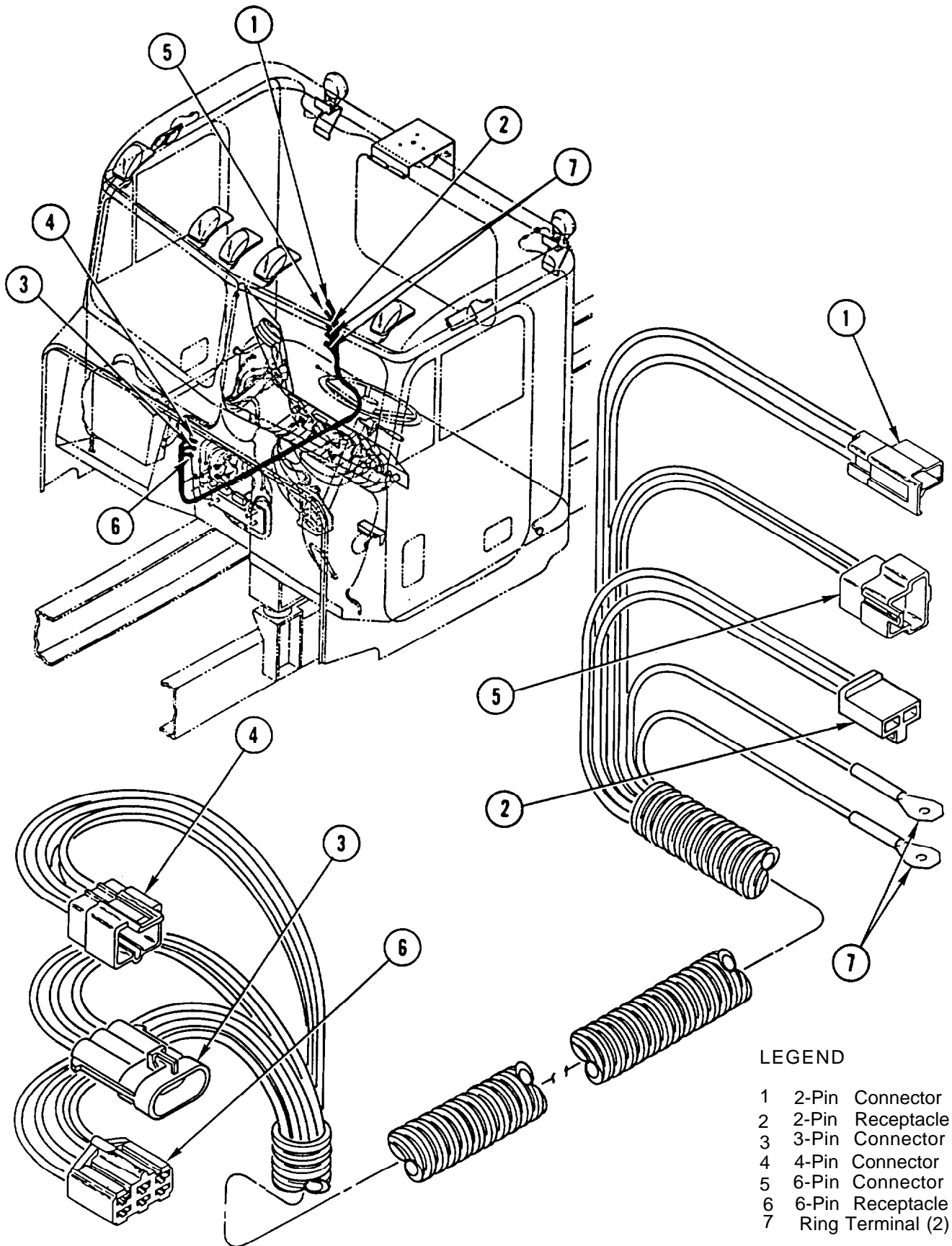

LEGEND

- 1 2-Pin Connector
- 2 2-Pin Receptacle
- 3 3-Pin Connector
- 4 4-Pin Connector
- 5 6-Pin Connector
- 6 6-Pin Receptacle
- 7 Ring Terminal (2)

CAB ANTI-LOCK BRAKE SYSTEM (ABS) WIRING HARNESS REPLACEMENT (M916A2 AND M917A1)

This task covers: a. Removal b. Cleaning c. Inspection d. Installation

INITIAL SETUP

Tools and Special Equipment:

Tool Kit, SC 5180-90-CL-N05

Equipment Description (Cont):

Reference	Condition Description
TM 9-2320-363-20	Batteries Disconnected

References:

TM 9-2320-363-10
TM 9-2320-363-20

REMOVAL

NOTE

- Wiring harness and leads are secured in place by clips, wire ties, cushion clamps, and screw terminals.
- Only remove hardware securing harness or lead to be removed.

REMOVE FRONT ANTI-LOCK BRAKE SYSTEM (ABS) WIRING HARNESS USING ILLUSTRATION AND LEGEND AS A GUIDE.

CLEANING

Use general cleaning methods to clean all parts.

INSPECTION

INSPECT ALL PARTS FOR WEAR OR DAMAGE.

INSTALLATION

NOTE

- Wiring harness and leads are secured in place by clips, wire ties, cushion clamps, and screw terminals.
- Make sure harness is secure and all hardware is tight.

INSTALL FRONT ANTI-LOCK BRAKE SYSTEM (ABS) WIRING HARNESS USING ILLUSTRATION AND LEGEND AS A GUIDE.

Cab Harness

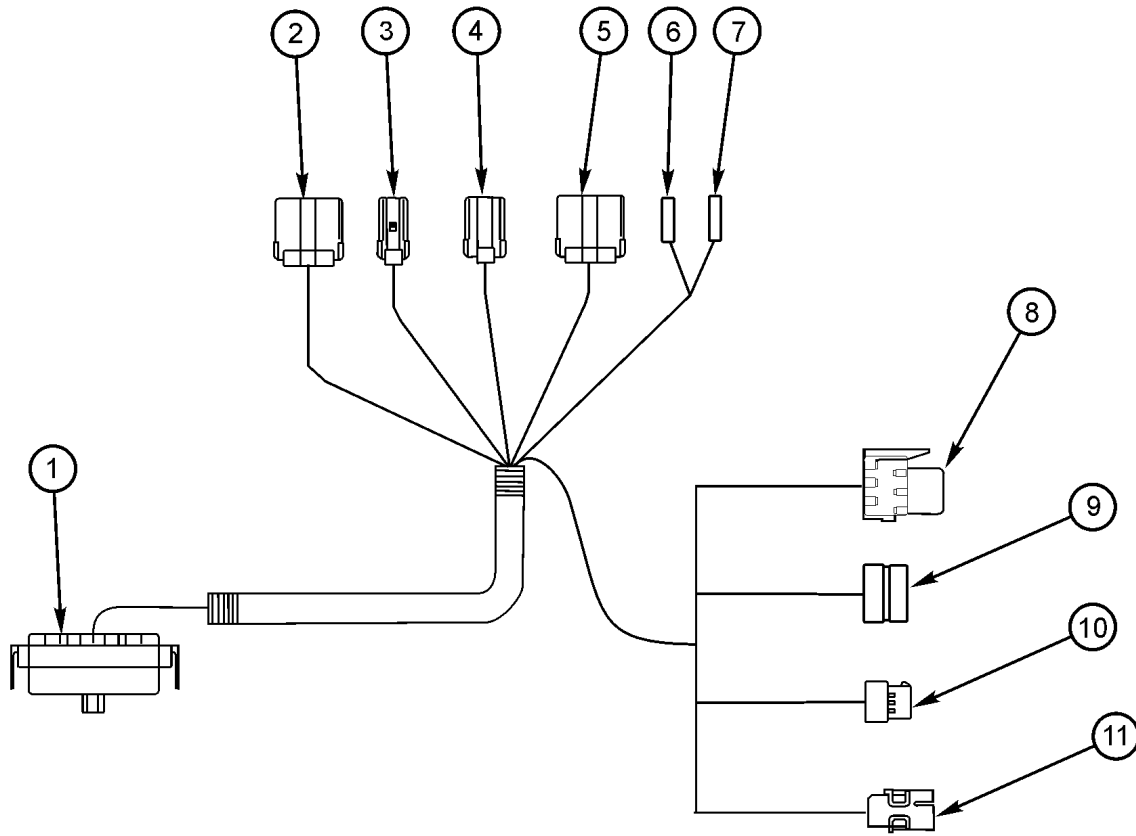

336-036

LEGEND

- 1 To Bulkhead Connector
- 2 EC1
- 3 EC2
- 4 EC3
- 5 EC4
- 6 Switch
- 7 Ground
- 8 R1
- 9 FH3
- 10 FH2
- 11 FH1

NOTE

Follow-on Maintenance:

Connect batteries (TM 9-2320-363-20).
 Perform ABS self-test (TM 9-2320-363-10).

FRONT ANTI-LOCK BRAKE SYSTEM (ABS) WIRING HARNESS REPLACEMENT (M915A2 AND M916A1)

This task covers: a. Removal b. Cleaning c. Inspection d. Installation

INITIAL SETUP

Tools and Special Equipment:

Tool Kit, SC 5180-90-CL-N05

References:

TM 9-2320-363-20

Equipment Condition:

Reference	Condition Description
TM 9-2320-363-20	Batteries Disconnected

REMOVAL

NOTE

- Wiring harness and leads are secured in place by clips, wire ties, cushion clamps.
- Only remove hardware securing harness or lead to be removed.

REMOVE FRONT ANTI-LOCK BRAKE SYSTEM (ABS) WIRING HARNESS USING ILLUSTRATION AND LEGEND AS A GUIDE.

CLEANING

Use general cleaning methods to clean all parts (page 2-30).

INSPECTION

Inspect all parts for wear or damage.

INSTALLATIO

NOTE

- Wiring harness and leads are secured in place by clips, wire ties, and cushion clamps.
- Make sure harness is secure and all hardware is tight.

INSTALL FRONT ANTI-LOCK BRAKE SYSTEM (ABS) WIRING HARNESS USING ILLUSTRATION AND LEGEND AS A GUIDE.

NOTE

Follow-on Maintenance:

Connect batteries (TM 9-2320-363-20).

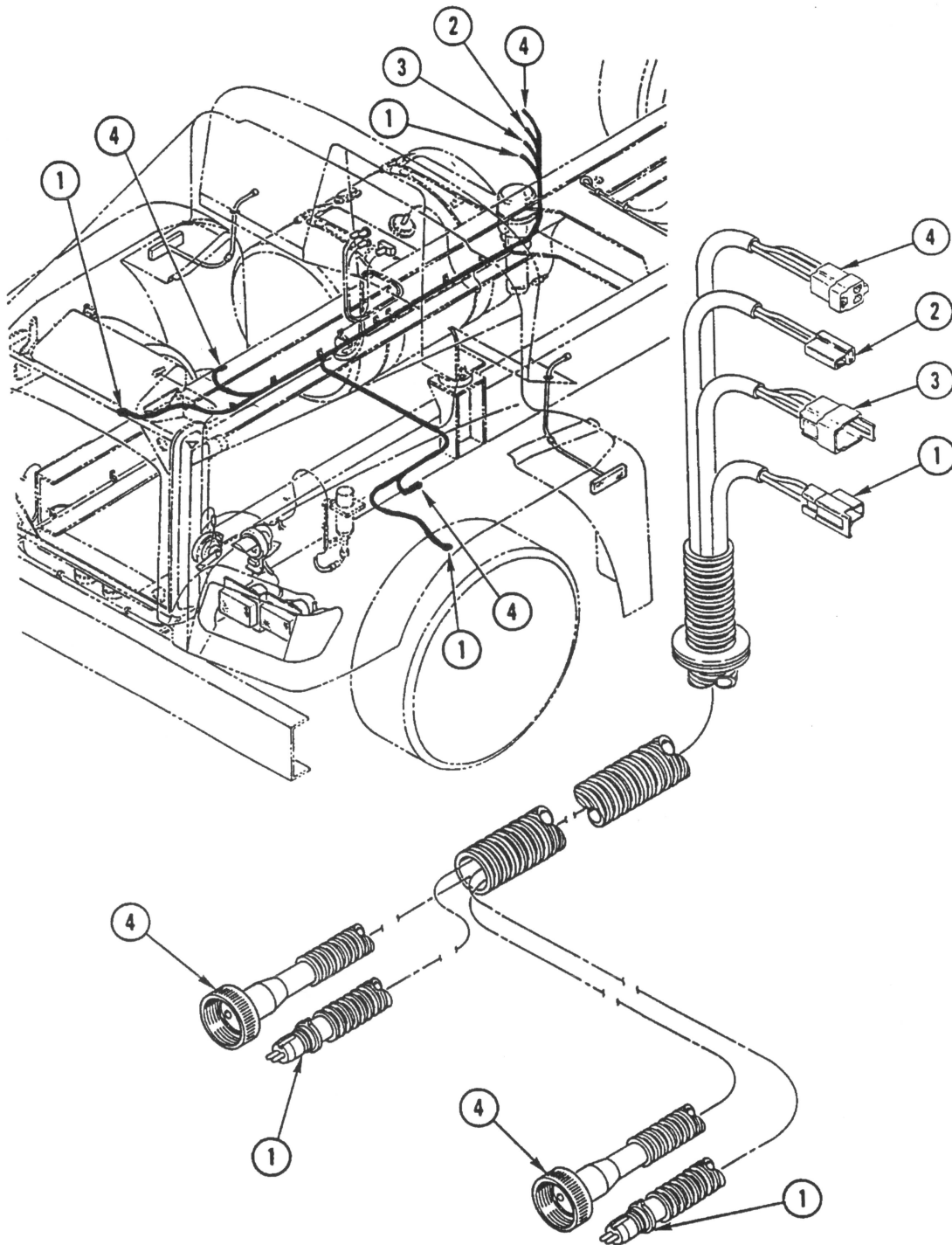

LEGEND

- 1 2-Pin Connector (4)
- 2 2-Pin Receptacle
- 3 3-Pin Connector
- 4 3-Pin Receptacle (3)

FRONT ANTI-LOCK BRAKE SYSTEM (ABS) WIRING HARNESS REPLACEMENT (M916A1 AND M917A1)

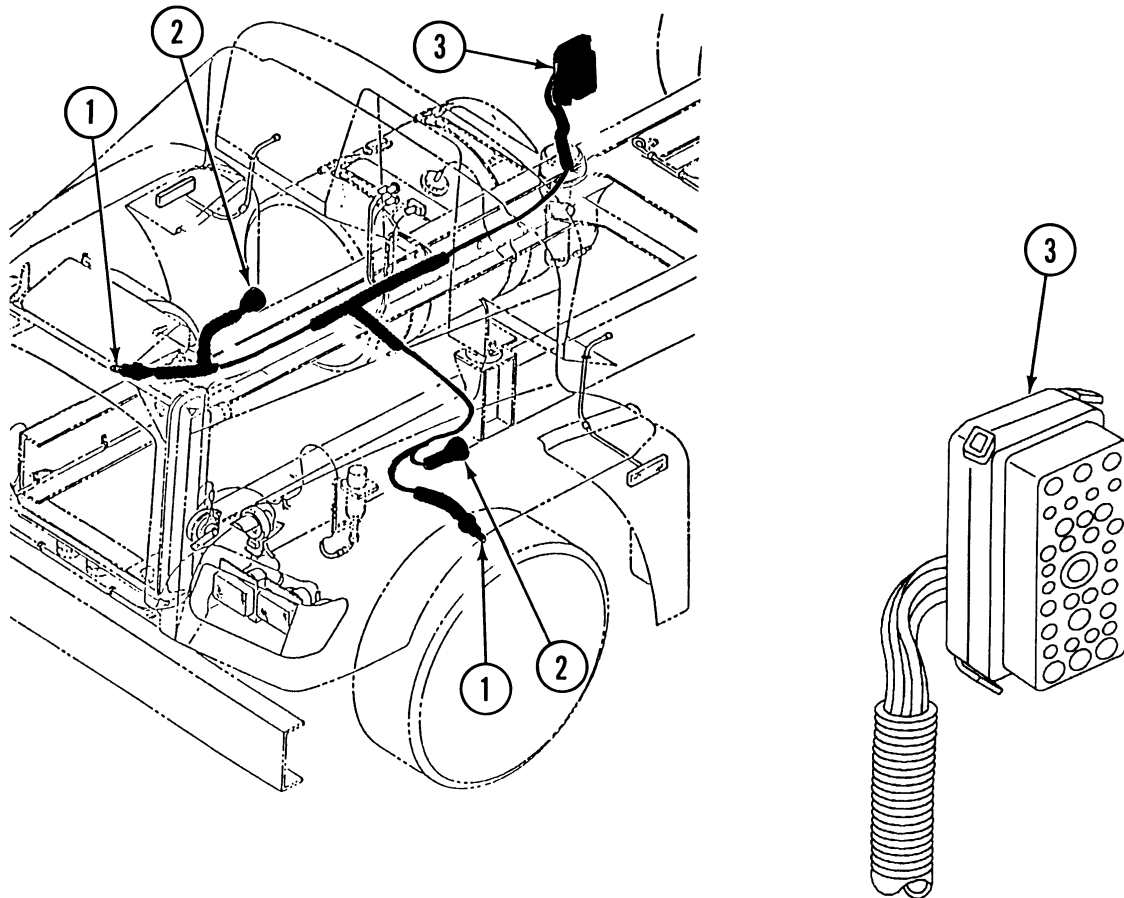

ALL EXCEPT M915A2 AND M916A1

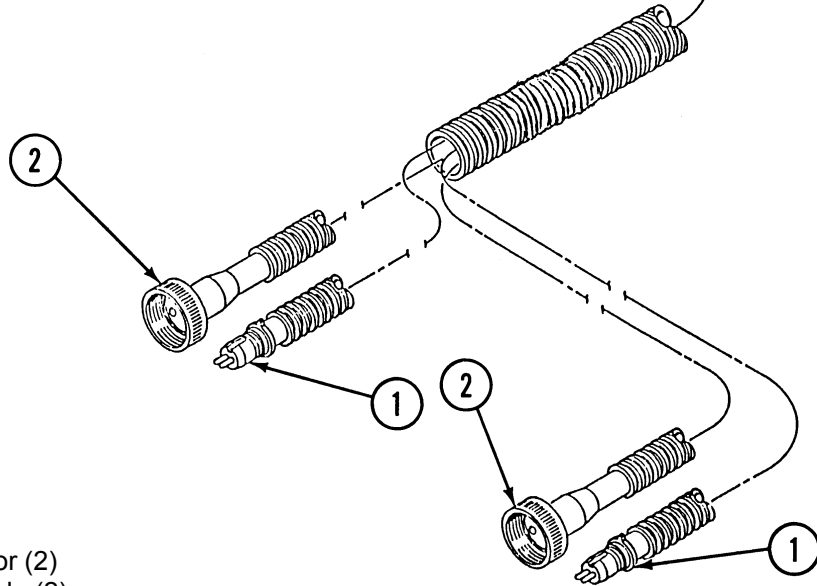

LEGEND

- 1 2-Pin Connector (2)
- 2 3-Pin Receptacle (2)
- 3 30-Pin Connector

FRONT ANTI-LOCK BRAKE SYSTEM (ABS) WIRING HARNESS REPLACEMENT (M916A1 AND M917A1)

This task covers: a. Removal b. Cleaning c. Inspection d. Installation

INITIAL SETUP

Tools and Special Equipment:

Tool Kit, SC 5180-90-CL-N05

Equipment Description (Cont):

Reference Description	Condition
-----------------------	-----------

References:

TM 9-2320-363-10
TM 9-2320-363-20

TM 9-2320-363-20 Batteries Disconnected

REMOVAL

NOTE

- Wiring harness and leads are secured in place by clips, wire ties, cushion clamps, and screw terminals.
- Only remove hardware securing harness or lead to be removed.

REMOVE FRONT ANTI-LOCK BRAKE SYSTEM (ABS) WIRING HARNESS USING ILLUSTRATION AND LEGEND AS A GUIDE.

CLEANING

Use general cleaning methods to clean all parts.

INSPECTION

INSPECT ALL PARTS FOR WEAR OR DAMAGE.

INSTALLATION

NOTE

- Wiring harness and leads are secured in place by clips, wire ties, cushion clamps, and screw terminals.
- Make sure harness is secure and all hardware is tight.

INSTALL FRONT ANTI-LOCK BRAKE SYSTEM (ABS) WIRING HARNESS USING ILLUSTRATION AND LEGEND AS A GUIDE.

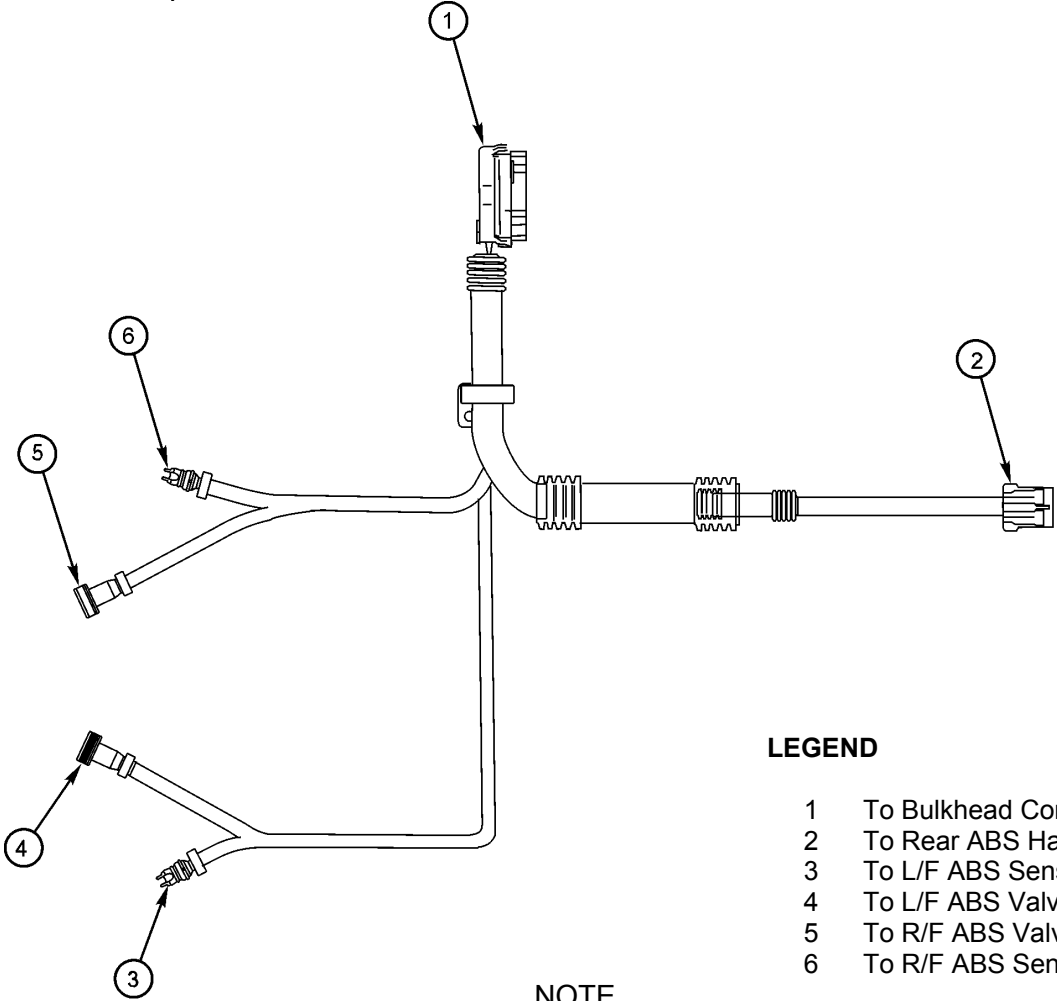
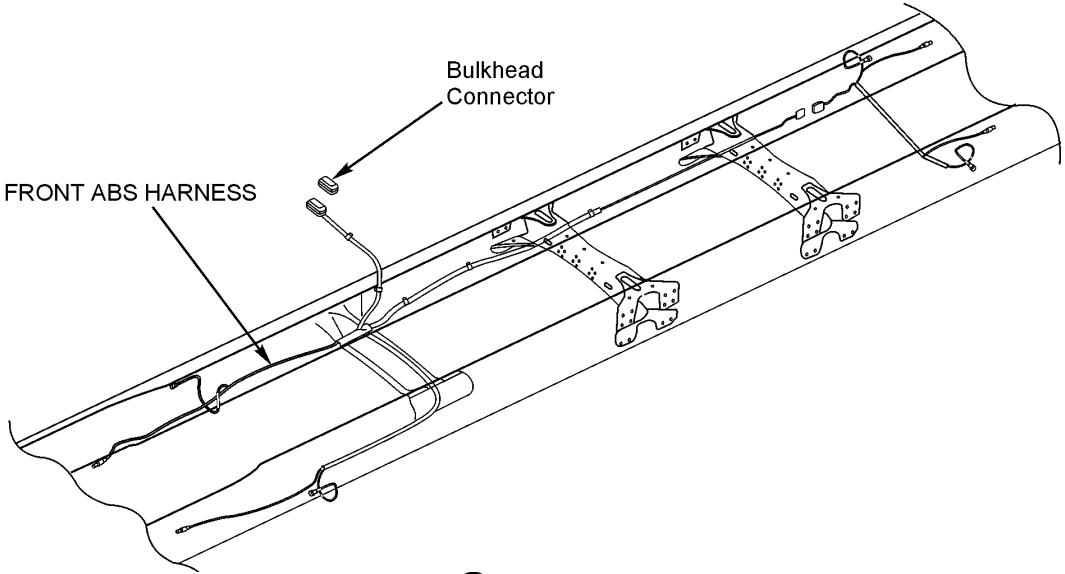

- LEGEND**
- 1 To Bulkhead Connectors
 - 2 To Rear ABS Harness
 - 3 To L/F ABS Sensor
 - 4 To L/F ABS Valve
 - 5 To R/F ABS Valve
 - 6 To R/F ABS Sensor

NOTE
Follow-on Maintenance:

Connect batteries (TM 9-2320-363-10).
Perform ABS self-test (TM 9-2320-363-10).

REAR ANTI-LOCK BRAKE SYSTEM (ABS) WIRING HARNESS REPLACEMENT (M916A2 AND M917A1)

This task covers: a. Removal b. Cleaning c. Inspection d. Installation

INITIAL SETUP

Tools and Special Equipment:

Tool Kit, SC 5180-90-CL-N05

Equipment Description (Cont):

Reference Description	Condition
-----------------------	-----------

References:

TM 9-2320-363-10
TM 9-2320-363-20

TM 9-2320-363-20 Batteries Disconnected

REMOVAL

NOTE

- Wiring harness and leads are secured in place by clips, wire ties, cushion clamps, and screw terminals.
- Only remove hardware securing harness or lead to be removed.

REMOVE REAR ANTI-LOCK BRAKE SYSTEM (ABS) WIRING HARNESS USING ILLUSTRATION AND TABLE AS A GUIDE.

CLEANING

Use general cleaning methods to clean all parts.

INSPECTION

INSPECT ALL PARTS FOR WEAR OR DAMAGE.

INSTALLATION

NOTE

- Wiring harness and leads are secured in place by clips, wire ties, cushion clamps, and screw terminals.
- Make sure harness is secure and all hardware is tight.

INSTALL REAR ANTI-LOCK BRAKE SYSTEM (ABS) WIRING HARNESS USING ILLUSTRATION AND TABLE AS A GUIDE.

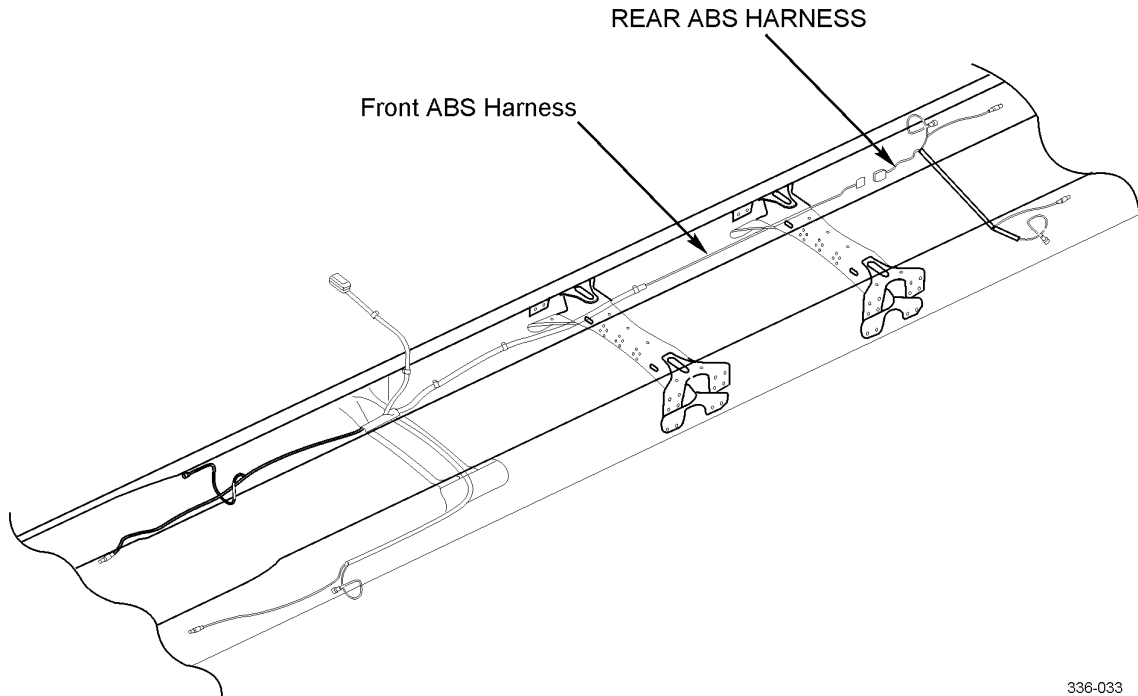

336-033

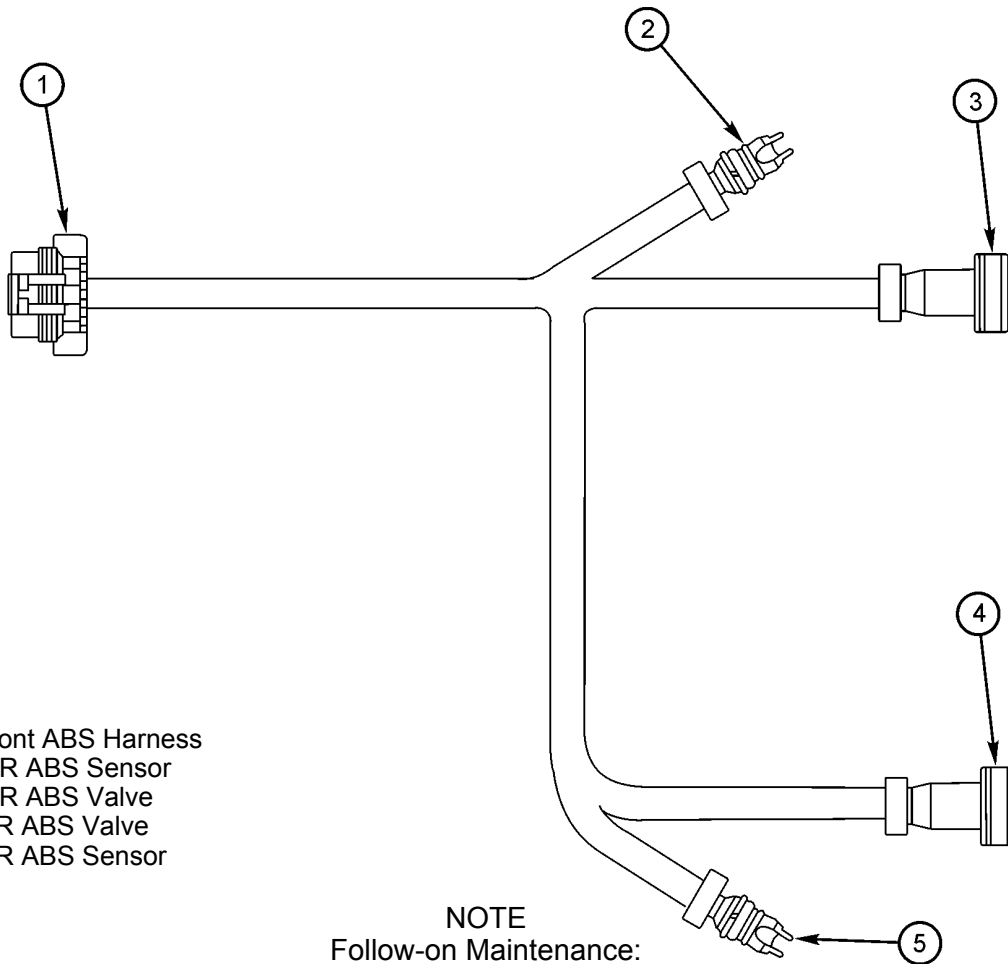

LEGEND

- 1 To Front ABS Harness
- 2 To R/R ABS Sensor
- 3 To R/R ABS Valve
- 4 To L/R ABS Valve
- 5 To L/R ABS Sensor

NOTE
Follow-on Maintenance:

Connect batteries (TM 9-2320-363-20).
Perform ABS self-test (TM 9-2320-363-10).

336-034

REAR ANTI-LOCK BRAKE SYSTEM (ABS) WIRING HARNESS REPLACEMENT (M915A2 AND M916A1)

This task covers: a. Removal b. Cleaning c. Inspection d. Installation

INITIAL SETUP

Tools and Special Equipment:

Tool Kit, SC 5180-90-CL-N05

References:

TM 9-2320-363-20

Equipment Condition:

Reference	Condition Description
TM 9-2320-363-20	Batteries Disconnected

REMOVAL

NOTE

- Wiring harness and leads are secured in place by clips, wire ties, and cushion clamps.
- Only remove hardware securing harness or lead to be removed.

REMOVE REAR ANTI-LOCK BRAKE SYSTEM (ABS) WIRING HARNESS USING ILLUSTRATION AND LEGEND AS A GUIDE.

CLEANING

Use general cleaning methods to clean all parts (page 2-30).

INSPECTION

Inspect all parts for wear or damage.

INSTALLATIO

NOTE

- Wiring harness and leads are secured in place by clips, wire ties, and cushion clamps.
- Make sure harness is secure and all hardware is tight.

INSTALL REAR ANTI-LOCK BRAKE SYSTEM (ABS) WIRING HARNESS USING ILLUSTRATION AND LEGEND AS A GUIDE.

NOTE

Follow-on Maintenance:

Connect batteries (TM 9-2320-363-20).

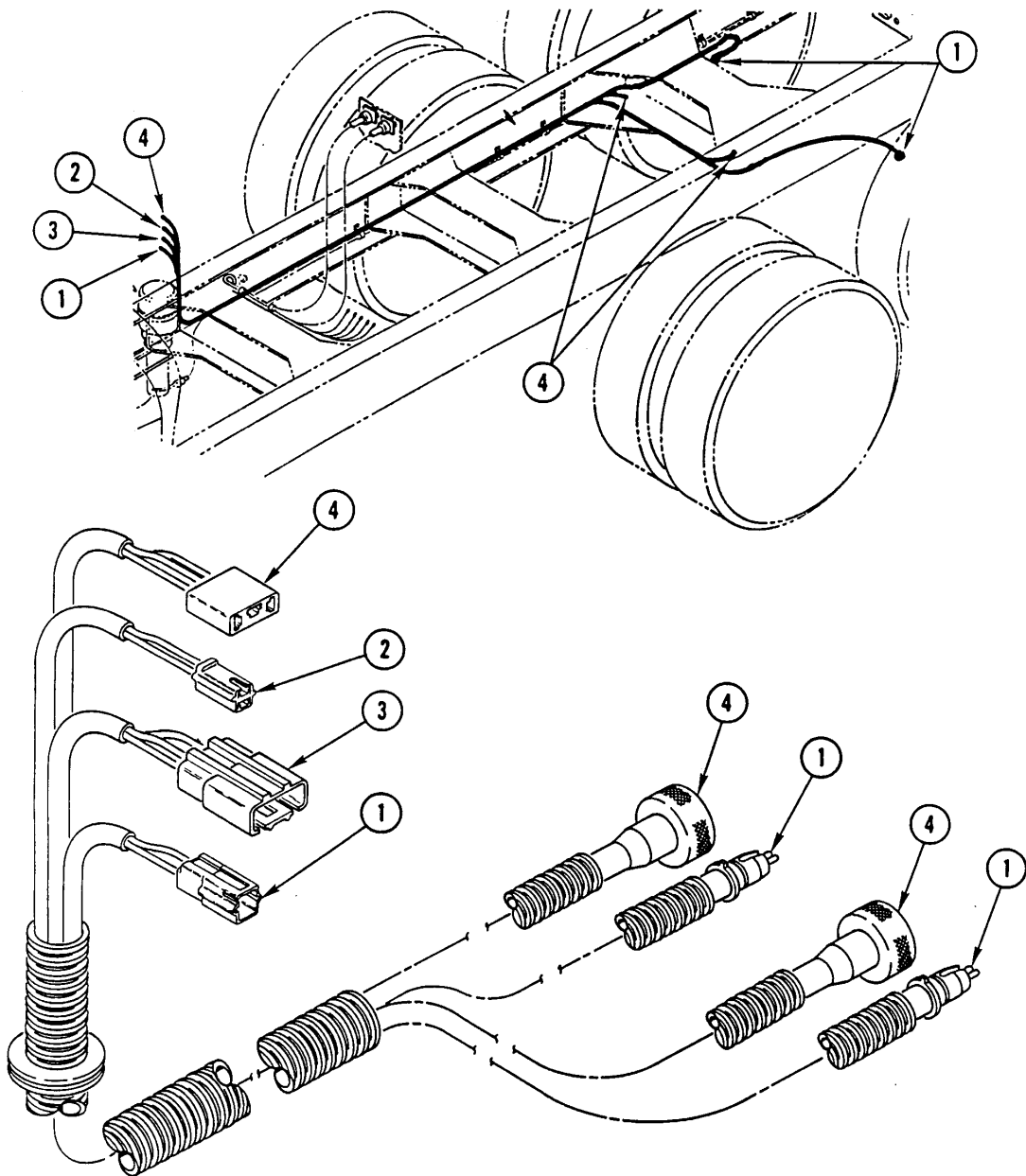

LEGEND

- 1 2-Pin Connector (3)
- 2 2-Pin Receptacle
- 3 3-Pin Connector
- 4 3-Pin Receptacle (3)

REAR ANTI-LOCK BRAKE SYSTEM (ABS) WIRING HARNESS REPLACEMENT (CONT)

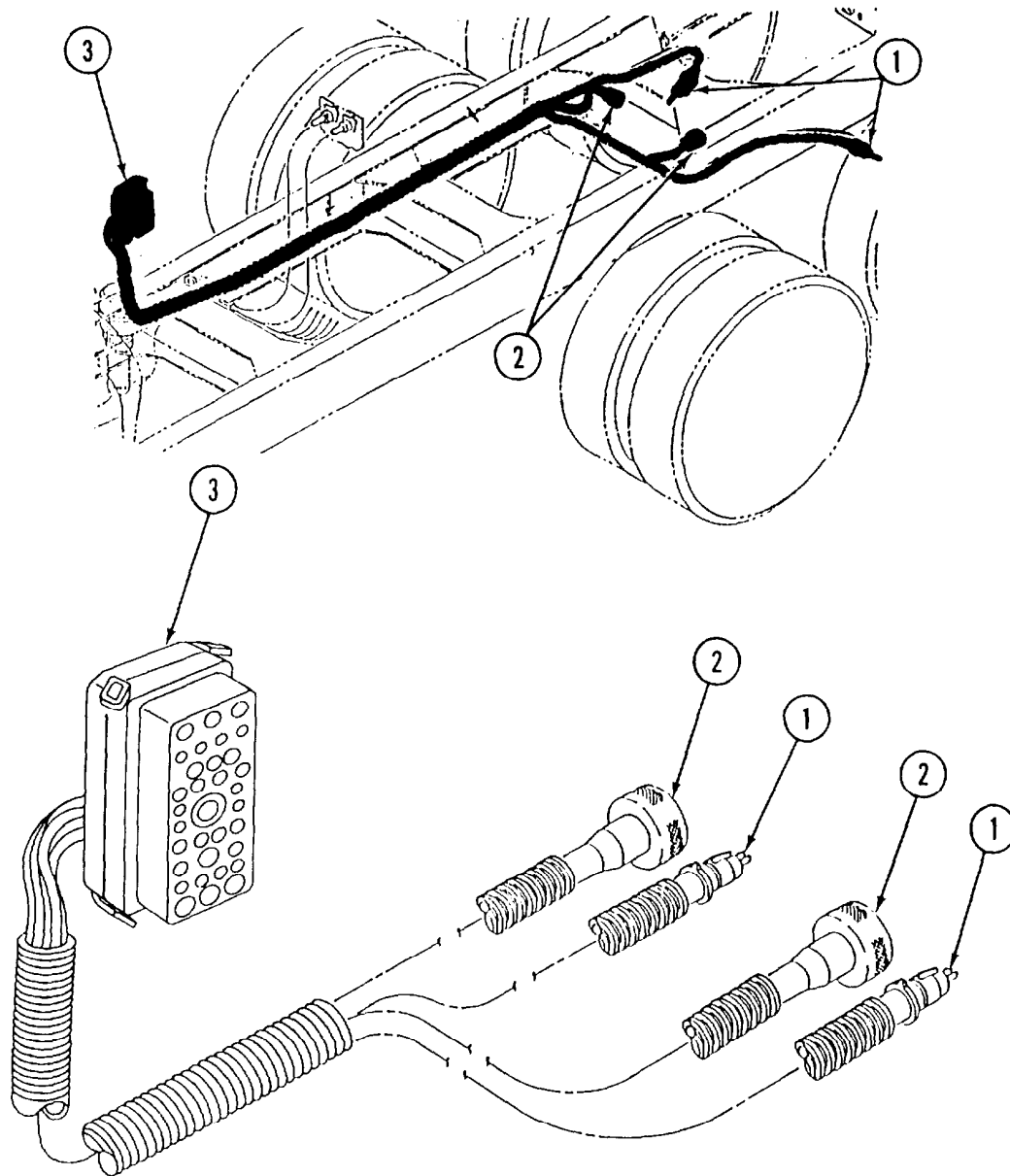

ALL EXCEPT M915A2 AND M916A1

LEGEND

- 1 2-Pin Connector (2)
- 2 2-Pin Receptacle (2)
- 3 30-Pin Connector

MCS CHASSIS WIRING HARNESS REPLACEMENT

This task covers: a. Removal b. Cleaning c. Inspection d. Installation

INITIAL SETUP

Applicable Configuration:

M917A1

Tools and Special Equipment:

Tool Kit, SC 5180-90-CL-N05

References:

TM 9-2320-363-20

Equipment Condition:

Reference	Condition Description
TM 9-2320-363-20	Batteries Disconnected

REMOVAL

NOTE

- Wiring harness and leads are secured in place by wire ties, cushion clamps, and screw terminals.
- Only remove hardware securing harness or lead to be removed.

DISCONNECT AND REMOVE MATERIAL CONTROL SYSTEM (MCS) CHASSIS WIRING HARNESS USING ILLUSTRATION AND TABLE GUIDE.

CLEANING

Use general cleaning methods to clean all parts (page 2-30).

INSPECTION

Inspect all parts for wear or damage.

INSTALLATIO

NOTE

- Wiring harness and leads are secured in place by wire ties, cushion clamps and screw terminals.
- Make sure harness is secure and all hardware is tight.

INSTALL AND CONNECT MATERIAL CONTROL SYSTEM (MCS) CHASSIS WIRING HARNESS USING ILLUSTRATION AND LEGEND AS A GUIDE.

NOTE

Follow-on Maintenance:

Connect batteries (TM 9-2320-363-20).

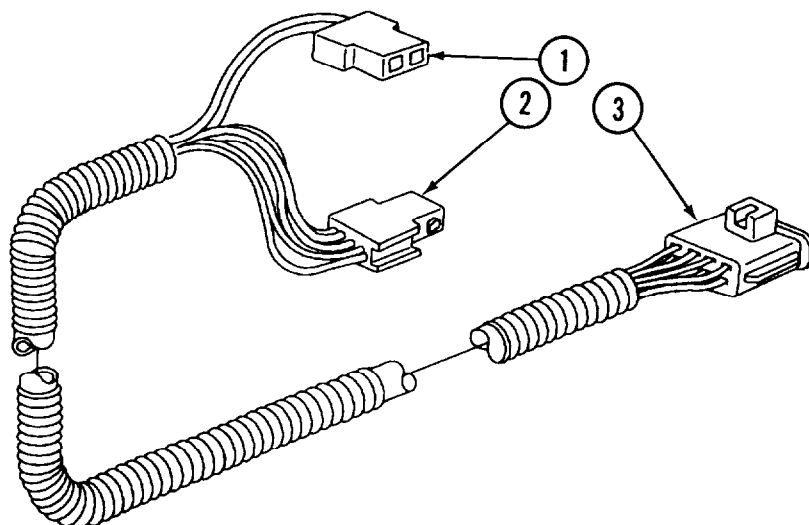
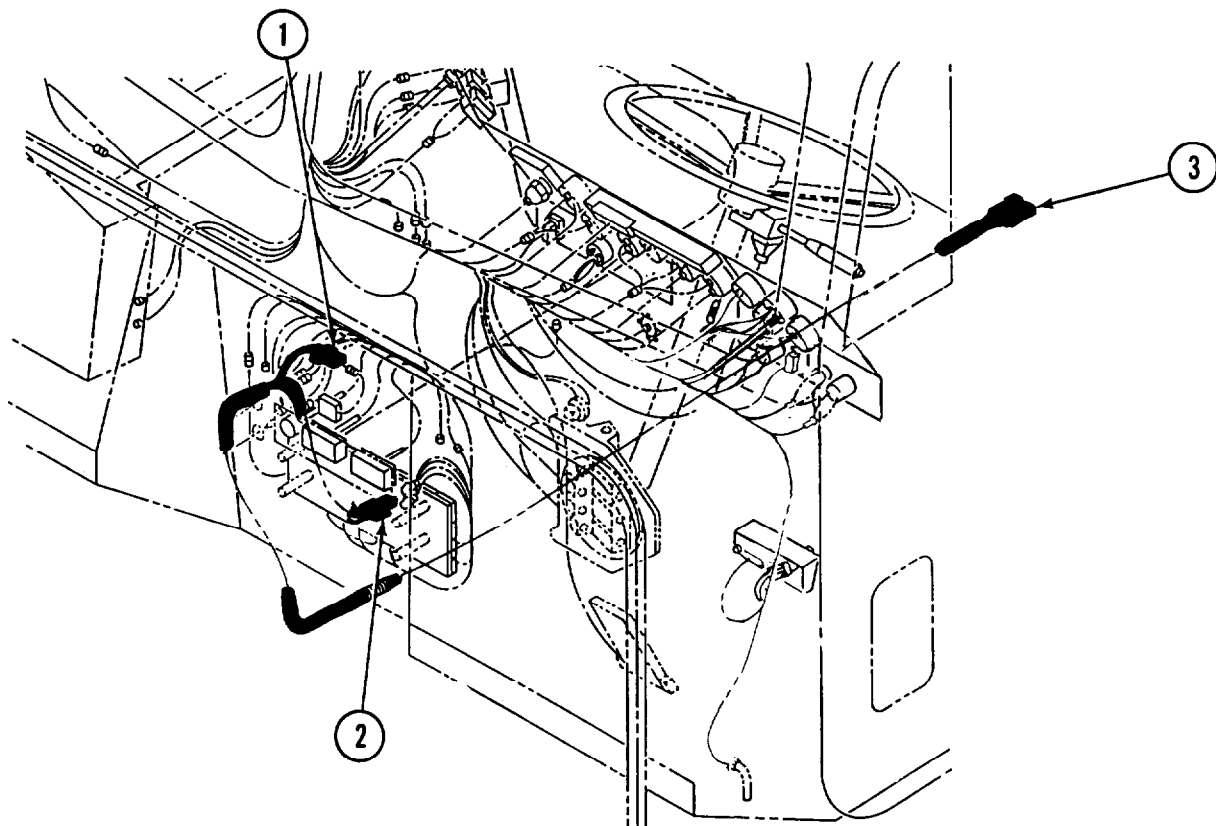

TABLE

QTY

- 1 2-Pin Connector
- 2 6-Pin Connector
- 3 8-Pin Connector

- 1
- 2
- 5

NOTE

Follow-on Maintenance:

Connect batteries (TM 9-2320-363-20).

CTIS WIRING HARNESS REPLACEMENT

This task covers: a. Removal b. Cleaning c. Inspection d. Installation

INITIAL SETUP

Applicable Configuration:

M917A1 and M917A1 w/MCS

Tools and Special Equipment:

Tool Kit, SC 5180-90-CL-N26

Equipment Condition:

Reference

TM 9-2320-363-20

Condition Description

Batteries Disconnected

REMOVAL

NOTE

- Wiring harness and leads are secured in place by wire ties, cushion clamps, and screw terminals.
- Only remove hardware securing harness lead to be removed.
- Tag all connectors and leads prior to removal to aid during installation.

DISCONNECT AND REMOVE CTIS WIRING HARNESS USING ILLUSTRATION AND TABLE AS A GUIDE.

CLEANING

Use general cleaning methods to clean all parts (page 2-30).

INSPECTION

Inspect all parts for wear or damage.

INSTALLATION

NOTE

- Wiring harness and leads are secured in place by wire ties, cushion clamps, and screw terminals.
- Make sure harness is secure and all hardware is tight.

INSTALL AND CONNECT CTIS WIRING HARNESS USING ILLUSTRATION AND TABLE AS A GUIDE.

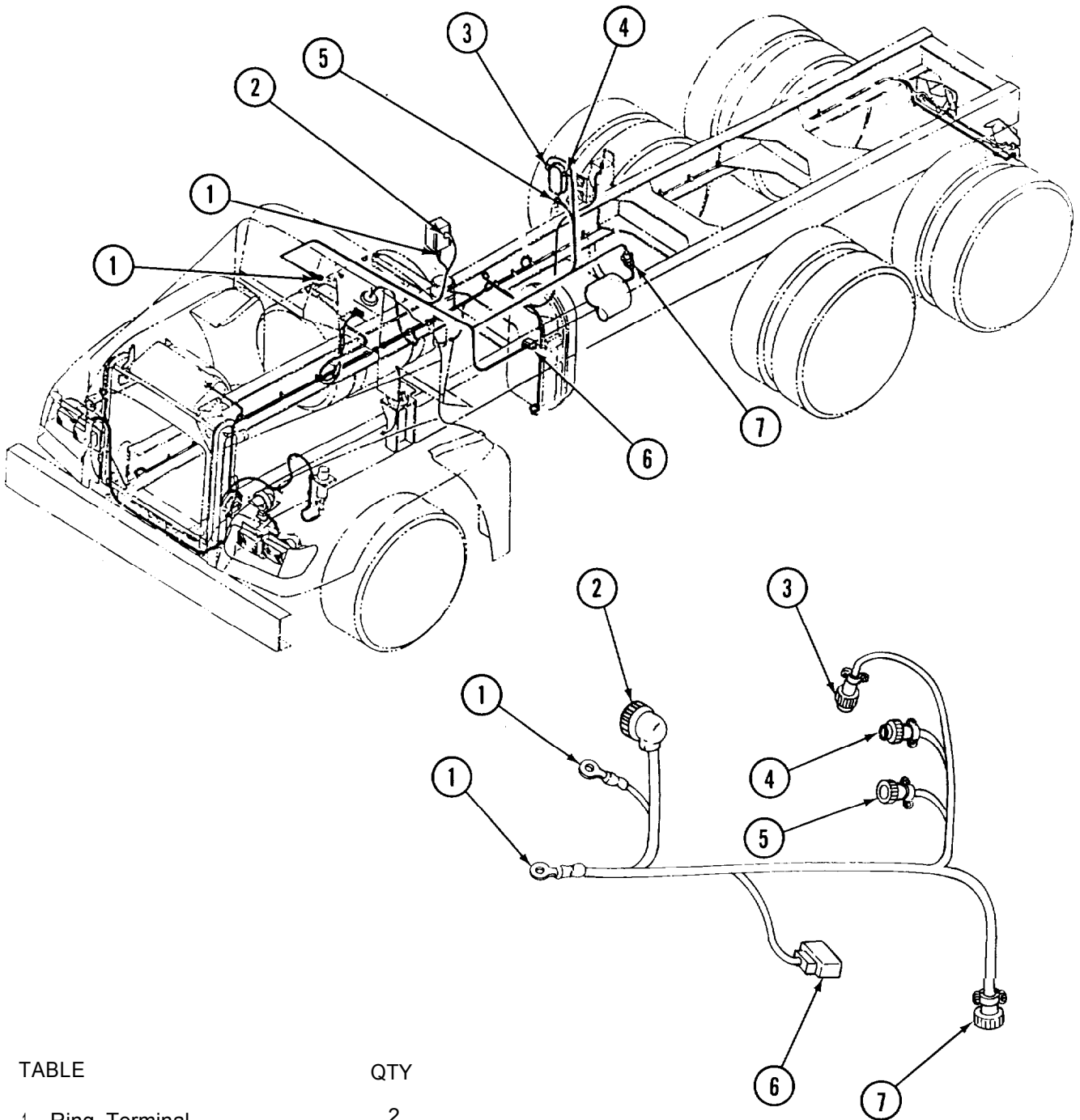

TABLE	QTY
1 Ring Terminal	2
2 Configuration Connector	1
3 9-Pin Male Connector	1
4 7-Pin Male Connector	1
5 4-Pin Female Connector	1
6 2-Pin Female Connector	1
7 2-Pin Female Connector	1

NOTE

Follow-on Maintenance:

Connect batteries (TM 9-2320-363-20).

PTO WIRING HARNESS REPLACEMENT

This task covers: a. Removal b. Cleaning c. Inspection d. installation

INITIAL SETUP

Applicable Configuration:

All except M915A2

Tools and Special Equipment:

Tool Kit, SC 5180-90-CL-N05

References:

TM 9-2320-363-20

Equipment Condition:

Reference	Condition	Description
TM 9-2320-363-20	Batteries	Disconnected

REMOVAL

NOTE

- Wiring harness and leads are secured in place by clips, wire ties, and cushion clamps.
- Only remove hardware securing harness lead to be removed.
- Tag all connectors and leads prior to removal to aid during installation.

REMOVE PTO WIRING HARNESS USING ILLUSTRATION AND TABLE AS A GUIDE.

CLEANING

Use general cleaning methods to clean all parts (page 2-30).

INSPECTION

Inspect all parts for wear or damage.

INSTALLATION

NOTE

- Wiring harness and leads are secured in place by clips, wire ties, and cushion clamps.
- Make sure harness is secure and all hardware is tight.

INSTALL PTO WIRING HARNESS USING ILLUSTRATION AND TABLE AS A GUIDE.

NOTE

Follow-on Maintenance:

Connect batteries (TM 9-2320-363-20).

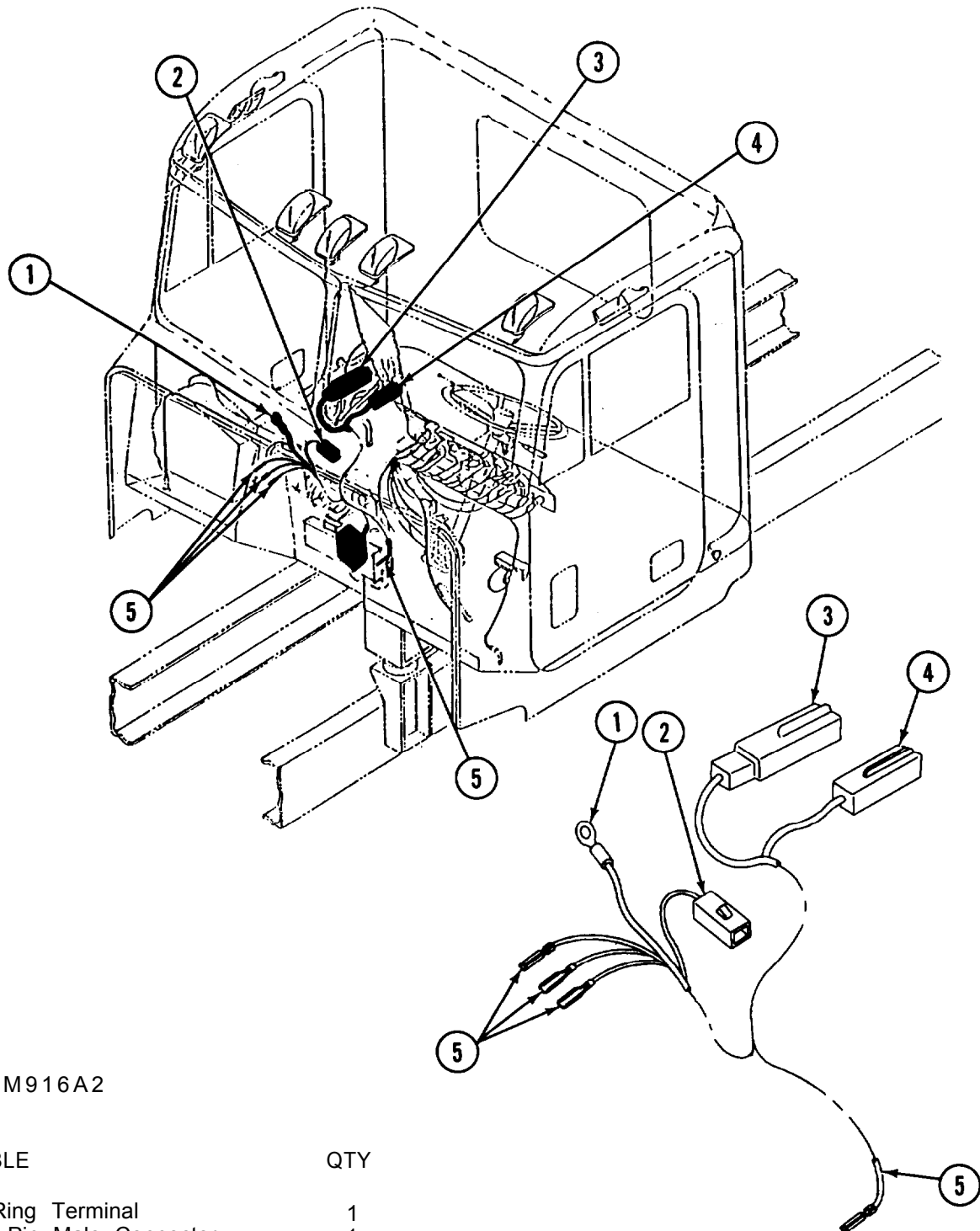

M916A2

TABLE

QTY

1	Ring Terminal	1
2	1-Pin Male Connector	1
3	2-Pin Male Connector	1
4	2-Pin Male Connector	1
5	1-Pin Male Connector	4

PTO WIRING HARNESS REPLACEMENT (CONT)

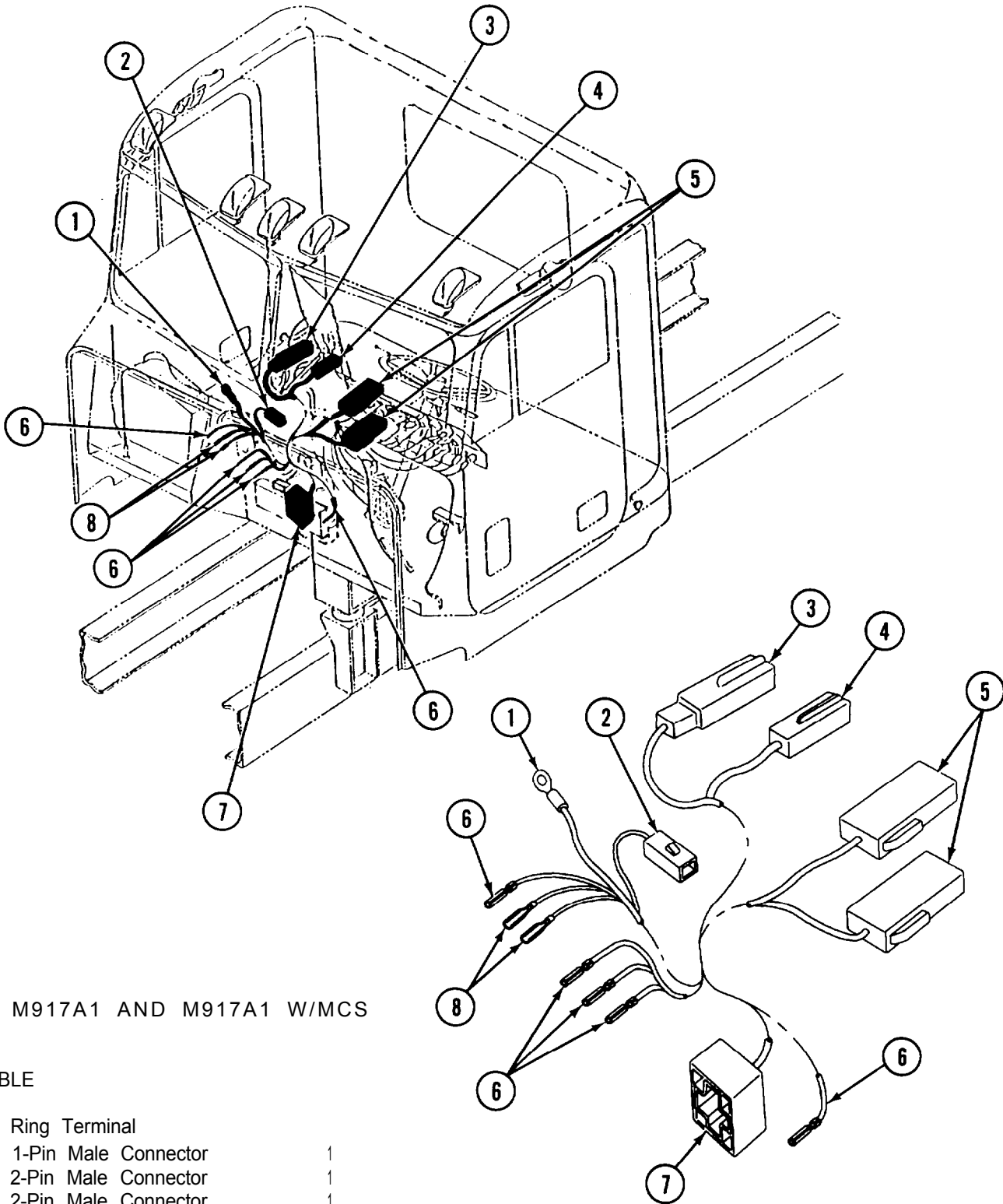

M917A1 AND M917A1 W/MCS

TABLE

1	Ring Terminal	
2	1-Pin Male Connector	1
3	2-Pin Male Connector	1
4	2-Pin Male Connector	1
5	2-Pin Male Connector	2
6	1-Pin Male Connector	5
7	4-Pin Relay Block	1
8	1-Pin Female Connector	2

MCS CAB CHASSIS WIRING HARNESS REPLACEMENT

This task covers: a. Removal b. Cleaning c. Inspection d. Installation

INITIAL SETUP

Applicable Configuration:

M917A1

Tools and Special Equipment:

Tool Kit, SC 5180-90-CL-N05

References:

TM 9-2320-363-20

Equipment Condition:

Reference	Condition Description
TM 9-2320-363-20	Batteries Disconnected

REMOVAL

NOTE

- Wiring harness and leads are secured in place by wire ties, cushion clamps, and screw terminals.
- Only remove hardware securing harness or lead to be removed.

DISCONNECT AND REMOVE MCS CAB WIRING HARNESS USING ILLUSTRATION AND TABLE GUIDE.

CLEANING

Use general cleaning methods to clean all parts (page 2-30).

INSPECTION

Inspect all parts for wear or damage.

INSTALLATIO

NOTE

- Wiring harness and leads are secured in place by wire ties, cushion clamps and screw terminals.
- Make sure harness is secure and all hardware is tight.

INSTALL AND CONNECT MCS CAB WIRING HARNESS USING ILLUSTRATION AND TABLE AS A GUIDE.

NOTE

Follow-on Maintenance:

Connect batteries (TM 9-2320-363-20).

MCS CAB WIRING HARNESS REPLACEMENT (CONT)

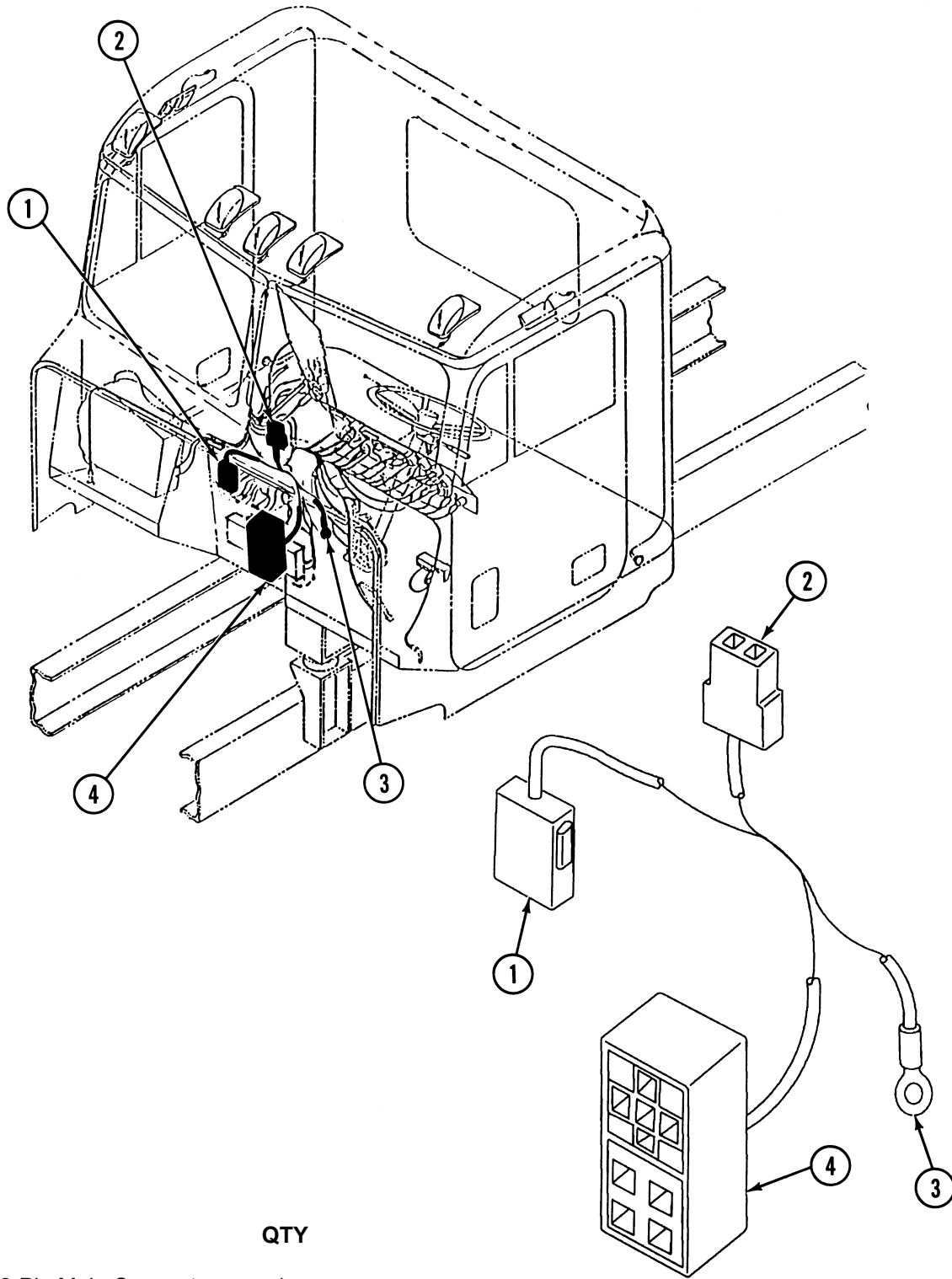

TABLE		QTY
1	2-Pin Male Connector	1
2	2-Pin Male Connector	1
3	Ring Terminal	1
4	Fuse/Relay Block	1

THIS PAGE INTENTIONALLY LEFT BLANK

STARTER SOLENOID REPLACEMENT

This task covers: a. Removal b. Cleaning c. Inspection d. Installation

INITIAL SETUP

Tools and Special Equipment:

Shop Equipment, SC 4910-95-CL-A31
Tool Kit, SC 5180-90-CL-N05

Materials/Parts:

Washer, Lock P/N Z0930-78423
Adhesive-Sealant Appendix B, Item 3

References:

TM 9-2320-363-20

Equipment Condition:

Reference	Condition	Description
TM 9-2320-363-20	Starter	Removed

REMOVAL

1. REMOVE NUT (1), LOCK WASHER (2), AND WIRE (3) FROM STARTER SOLENOID (4). DISCARD LOCK WASHER.

CAUTION

Preheating may be required to remove nut without damaging plastic base.

2. REMOVE NUT (5) FROM STARTER SOLENOID (4).
3. HOLD NUT (6) ON STARTER MOTOR (7) AND REMOVE NUT (8) AND JUMPER (9) FROM STUD (10).
4. REMOVE TWO SCREWS (11).
5. PULL STARTER SOLENOID (4) AWAY FROM HOUSING (12) AND ROTATE SO MOUNTING BRACKET (13) FACES AWAY FROM STARTER MOTOR (7).
6. REMOVE SPOOL (14) FROM SHIFT FORK (15).

NOTE

It may be necessary to use soft-jawed vise to hold solenoid plunger for removal of spool.

7. REMOVE SPOOL (14) AND BOOT (16) FROM SOLENOID PLUNGER (17).

CLEANING

Use general cleaning methods to clean all parts (page 2-30).

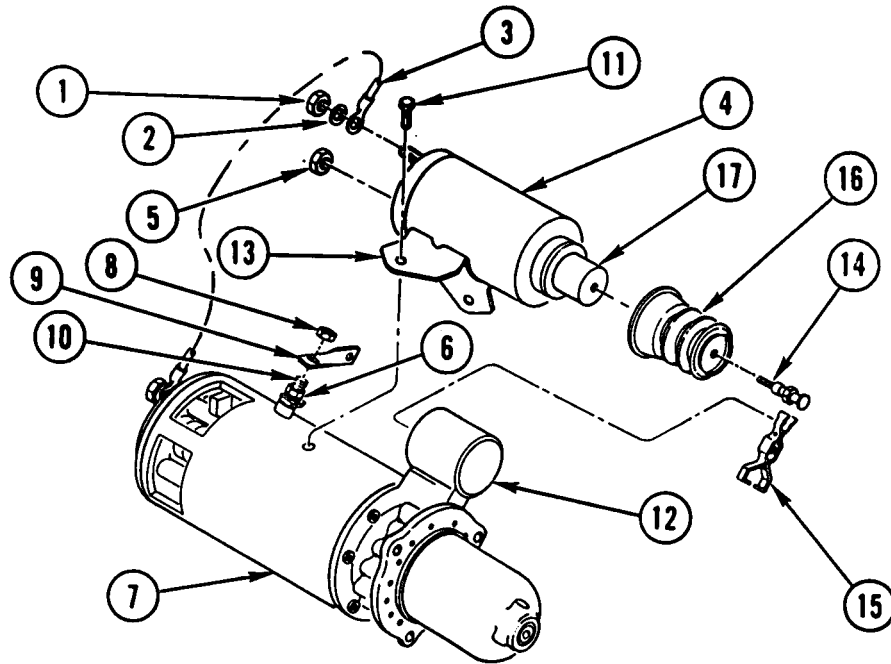

INSPECTION

Inspect all pads for wear or damage.

1. INSTALL BOOT (16) AND SPOOL (14) ON SOLENOID PLUNGER (17).
2. ROTATE STARTER SOLENOID (4) SO MOUNTING BRACKET (13) FACES AWAY FROM STARTER MOTOR (7).
3. INSTALL SPOOL (14) IN SHIFT FORK (15).
4. ROTATE STARTER SOLENOID (4) TO MOUNTING POSITION AND PRESS FLUSH WITH HOUSING (12).
5. APPLY ADHESIVE-SEALANT TO THREADS AND INSTALL TWO SCREWS (11).
6. INSTALL JUMPER (9) ON STUD (10).
7. APPLY ADHESIVE-SEALANT TO LAST 1/4 IN. OF THREADS ON STUD (10), HOLD NUT (6) AND INSTALL NUT (8). TIGHTEN NUT (8) TO 21-29 LB-FT (28-39 N.m).
8. INSTALL NUT (5) ON STARTER SOLENOID (4). TIGHTEN NUT TO 18-22 LB-FT (24-30 N.m).
9. INSTALL WIRE (3), NEW LOCK WASHER (2), AND NUT (1) ON STARTER SOLENOID (4).

NOTE

Follow-on Maintenance:
Install starter (TM 9-2320-363-20).

ENGINE RETARDER SOLENOID TEST AND REPLACEMENT

This task covers: a. Test b. Removal c. Cleaning d. Installation

INITIAL SETUP

Tools and Special Equipment:

Shop Equipment, SC 4910-95-CL-A31
 Tool Kit, SC 5180-90-CL-N05

Materials/Parts:

Solenoid	P/N 016440
Ring, Seal	P/N 001081
Ring, Seal	P/N 001082
Ring, Seal	P/N 001083

Materials/Parts (Cont):

Toweling, Paper	Appendix B, Item 63
Oil, Lubricating	Appendix B, Item 37

Equipment Condition:

Reference	Condition Description
Page 3-71	Rocker Cover Removed

TEST

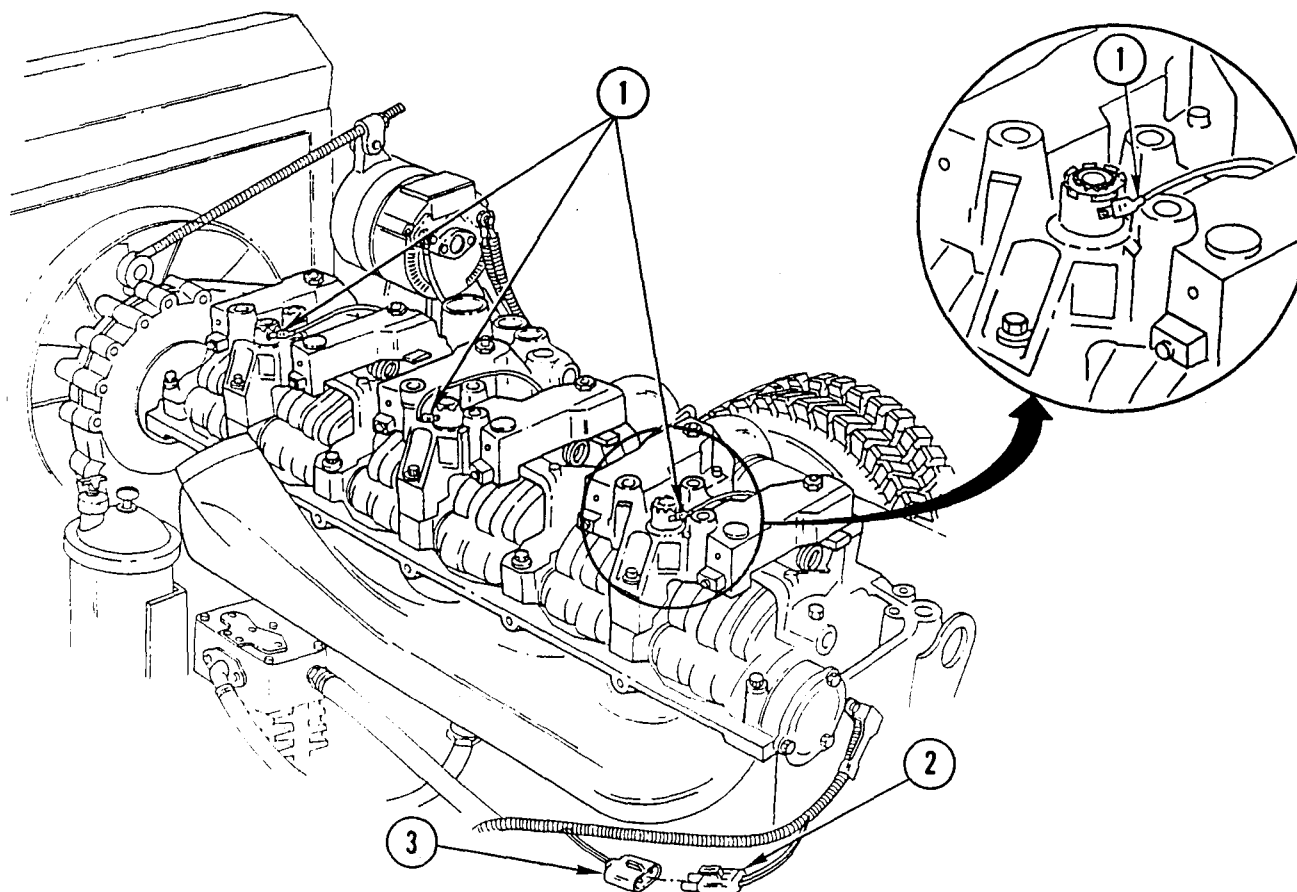

1. MAKE SURE THREE WIRING HARNESS SOLENOID CONNECTORS AND TERMINALS (1) ARE FULLY ENGAGED AND TIGHT.

CAUTION

Grasp only connectors when disconnecting harnesses. Do not pull on wires to prevent damage to equipment.

2. DISCONNECT ENGINE RETARDER WIRING HARNESS CONNECTOR (2) FROM VEHICLE ELECTRICAL HARNESS (3).

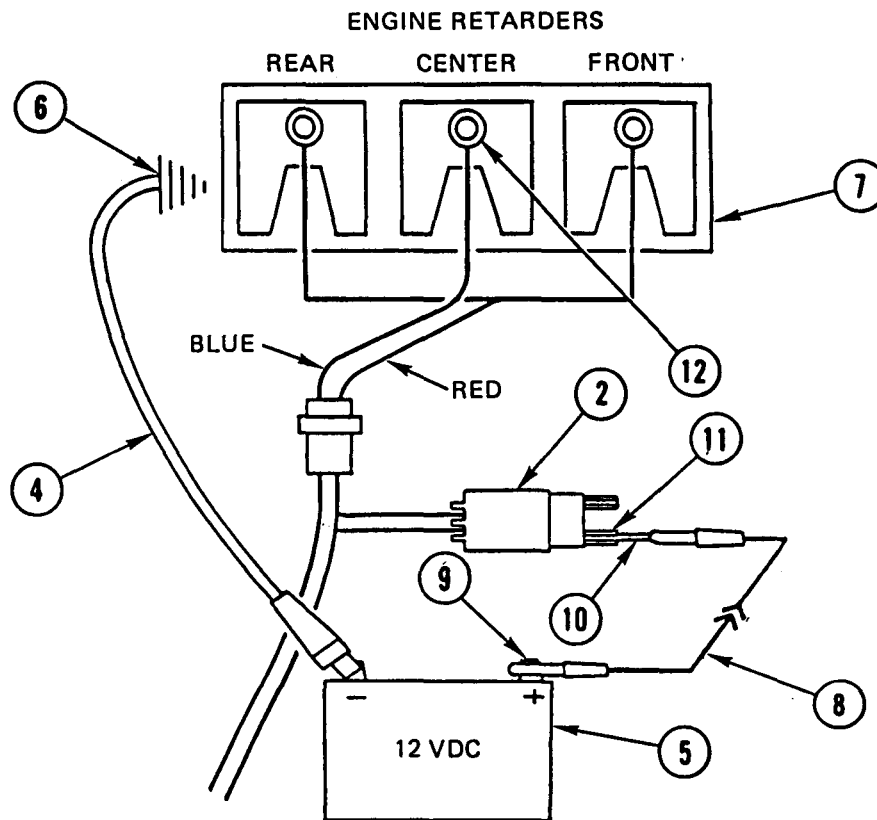

3. CONNECT JUMPER LEAD (4) TO NEGATIVE (-) TERMINAL ON 12 VOLT DC POWER SOURCE (5) AND TO GROUND (6) ON CYLINDER HEAD (7).
4. CONNECT JUMPER LEAD (8) TO POWER SOURCE POSITIVE (+) TERMINAL (9) AND INSERT JUMPER LEAD PROBE (10) INTO BLUE WIRE TERMINAL CAVITY (11) OF ENGINE RETARDER WIRING HARNESS CONNECTOR (2).

NOTE

When power is applied, solenoid of center engine retarder assembly should be activated. Activation can be heard and noted by movement of solenoid cap.

5. APPLY POWER.
6. REPEAT APPLYING AND REMOVING POWER 2 OR 3 TIMES TO ENSURE CENTER SOLENOID (12) IS OPERATING PROPERLY.

ENGINE RETARDER SOLENOID TEST AND REPLACEMENT (CONT)

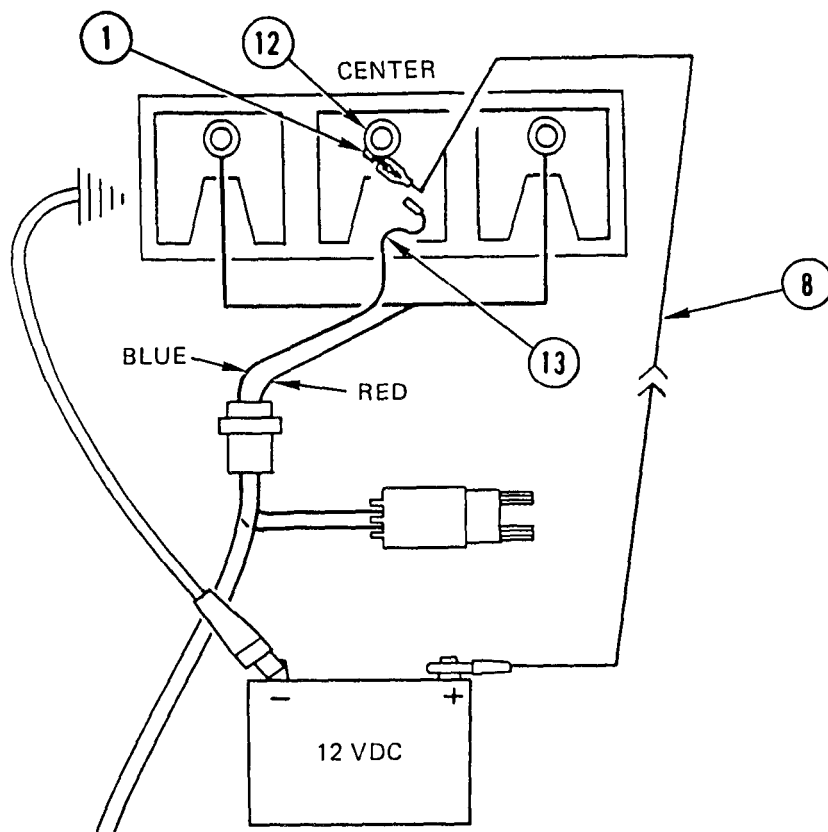

NOTE

When power is applied, solenoid of center engine retarder assembly should be activated. Activation can be heard and noted by movement of solenoid cap.

7. IF SOLENOID CAP (12) DOES NOT MOVE, REMOVE BLUE WIRE (13) FROM SOLENOID TERMINAL (1) AND CONNECT POWER SOURCE POSITIVE JUMPER LEAD (8) TO SOLENOID TERMINAL (1). APPLY POWER.
8. IF SOLENOID OPERATES, REPAIR OR REPLACE BLUE WIRE OR CHECK CONNECTOR FOR BREAKS. IF SOLENOID FAILS TO OPERATE, REMOVE AND DISCARD SOLENOID.

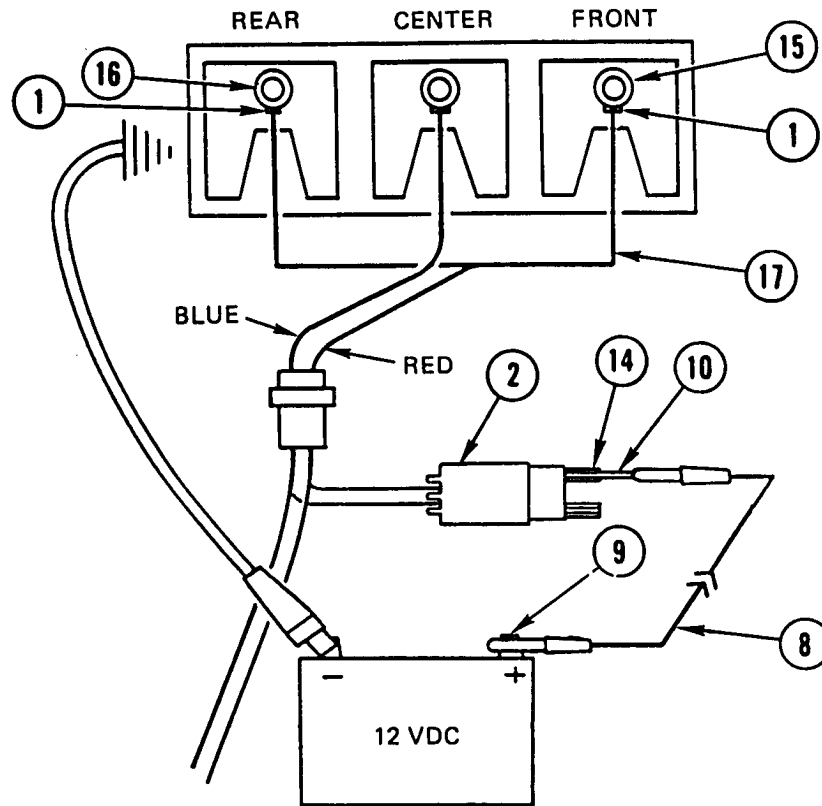

9. CONNECT JUMPER LEAD (8) TO POWER SOURCE POSITIVE (+) TERMINAL (9) AND INSERT JUMPER LEAD PROBE (10) INTO RED WIRE TERMINAL CAVITY (14) OF ENGINE RETARDER WIRING HARNESS CONNECTOR (2).

NOTE

When power is applied, solenoids of front and rear engine retarder assemblies should be activated. Activation can be heard and noted by movement of solenoid cap.

10. APPLY POWER.
11. REPEAT APPLYING AND REMOVING POWER 2 OR 3 TIMES TO ENSURE FRONT AND REAR SOLENOIDS (15 AND 16) ARE OPERATING PROPERLY.

NOTE

When power is applied, solenoids of front and rear engine retarder assemblies should be activated. Activation can be heard and noted by movement of solenoid cap.

12. IF SOLENOID CAP (15 OR 16) DOES NOT MOVE, REMOVE RED WIRE (17) FROM SOLENOID TERMINAL (1) AND CONNECT POWER SOURCE POSITIVE JUMPER LEAD (8) TO SOLENOID TERMINAL (15 OR 16). APPLY POWER.
13. IF SOLENOID OPERATES, REPAIR OR REPLACE BLUE WIRE OR CHECK CONNECTOR FOR BREAKS. IF SOLENOID FAILS TO OPERATE, REMOVE AND DISCARD SOLENOID.

ENGINE RETARDER SOLENOID TEST AND REPLACEMENT (CONT)

REMOVAL

CAUTION

Grasp only connector when removing wiring harness solenoid connector from solenoid terminal. Do not pull on wire to prevent damage to equipment.

NOTE

Procedure is the same for all three solenoids.

1. DISCONNECT WIRING HARNESS SOLENOID CONNECTOR (1) FROM SOLENOID TERMINAL (2).
2. REMOVE SOLENOID (3) FROM ENGINE RETARDER ASSEMBLY HOUSING (4).

NOTE

Three seal rings should come out with solenoid. If lower seal ring remains at bottom of engine retarder solenoid housing bore, remove seal with piece of wire and discard seal.

3. DISCARD SOLENOID (3) AND THREE SEAL RINGS (5, 6, AND 7).

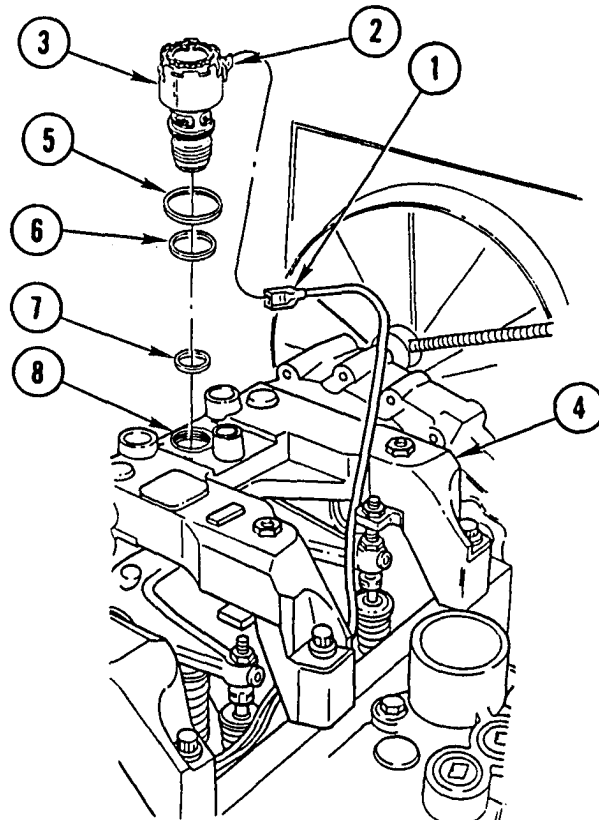

CLEANING

NOTE

Do not use rags or cloth towels for cleaning.

CLEAN RETARDER SOLENOID HOUSING BORE (8) IN ENGINE RETARDER ASSEMBLY HOUSING (4) WITH CLEAN PAPER TOWELING.

INSTALLATION

1. COAT NEW UPPER SEAL RING (5) AND NEW CENTER SEAL RING (6) WITH CLEAN ENGINE LUBRICATING OIL AND INSTALL ON NEW SOLENOID (3).
2. INSTALL NEW LOWER SEAL RING (7) IN BOTTOM OF RETARDER SOLENOID HOUSING BORE (8).

CAUTION

Make sure seal rings are properly seated on solenoid. Take care not to twist seal rings when installing solenoid to prevent damage to equipment.

3. THREAD SOLENOID (3) INTO ENGINE RETARDER ASSEMBLY HOUSING (4) AND TIGHTEN TO 4-6 LB-FT (6-8 N.m).
4. CONNECT WIRING HARNESS SOLENOID CONNECTOR (1) TO SOLENOID TERMINAL (2).

NOTE

Install rocker cover (page 3-71).
Follow-on Maintenance:

CHAPTER 5
FRONT AXLE MAINTENANCE

OVERVIEW

This chapter illustrates and describes procedures for maintenance of the front axle and related parts. A list of tasks contained in this chapter is shown below.

	Page
Front Axle Replacement (All Except M915A2)	5-2
Front Axle Shaft Replacement and Repair (All Except M915A2)	5-7
Front Ball Socket Replacement (All Except M915A2)	5-15
Front Ball, Bushing, and Oil Seal Replacement (All Except M915A2)	5-30
Front Differential Carrier Replacement (All Except M915A2)	5-34
Front Yoke and Oil Seal Replacement (All Except M915A2)	5-38
Front Axle Assembly Replacement (M915A2)	5-40
Front Steering Knuckle Replacement and Repair (M915A2)	5-44
Tie Rod Replacement and Repair	5-52
Front Steering Arm Replacement (M915A2)	5-56
Front Cross Tube Arm Replacement	5-58
Front Axle Caster Adjustment (M915A2)	5-60

FRONT AXLE REPLACEMENT

This task covers: a. Removal b. Cleaning c. Inspection d. Installation

INITIAL SETUP

Applicable Configuration:

All except M915A2

Tools and Special Equipment:

Shop Equipment, SC 4910-95-CL-A31
Tool Kit, SC 5180-90-CL-N05

Materials/Parts:

Pin, Cotter (2)

Pin, Cotter (2)

Alumilastic Appendix B, Item 6

Personnel Required: (2)

References:

TM 9-2320-363-20

Equipment Condition:

Reference	Condition	Description
TM 9-2320-363-20	Driveline	Removed
TM 9-2320-363-20	Front Brake Spider and Brake Chamber Bracket	Removed
TM 9-2320-363-20	Axle Oil	Drained

General Safety Instructions:

WARNING

Front axle weighs 1,850 lb (839 kg). Support front axle with suitable floor jack during removal or installation to prevent possible injury to personnel.

REMOVAL

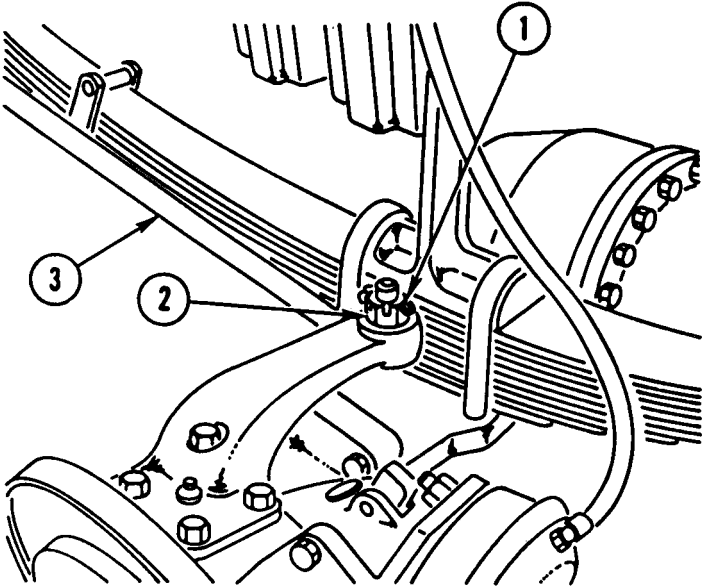

NOTE

Procedure is the same for both sides except where noted.

- 1. ON LEFT SIDE, REMOVE COTTER PIN (1) AND CASTELLATED NUT (2) AND SET DRAG LINK (3) ASIDE. DISCARD COTTER PIN.

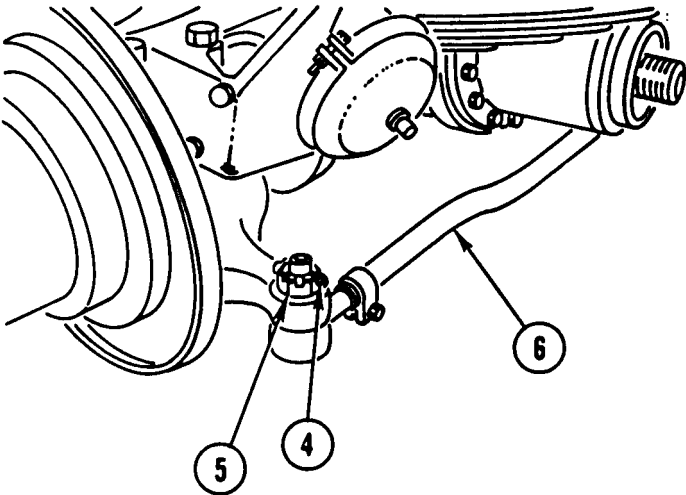

- 2. REMOVE COTTER PIN (4), CASTELLATED NUT (5), AND TIE ROD (6). DISCARD COTTER PIN.

FRONT AXLE REPLACEMENT (CONT)

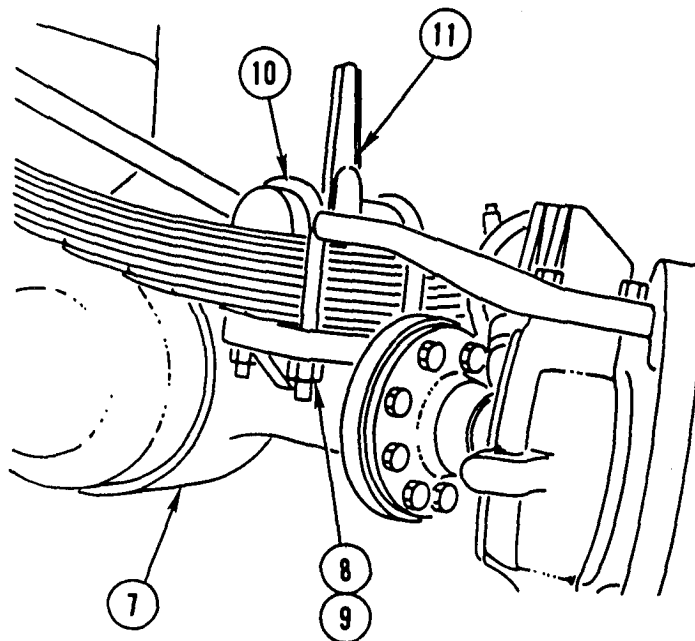

WARNING

Front axle weighs 1,850 lb (839 kg). Support front axle with suitable floor jack during removal to prevent possible injury to personnel.

NOTE

Make sure front of vehicle is blocked up enough to allow removal of axle.

3. POSITION SUITABLE FLOOR JACK UNDER EACH END OF AXLE (7).
4. REMOVE FOUR NUTS (8), FOUR WASHERS (9), TWO U-BOLTS (10), AND AXLE STOP (11).
5. LOWER AXLE (7) AND ROLL OUT FROM UNDER VEHICLE.

NOTE

If axle housing is to be replaced, remove front differential carrier assembly (page 5-34).

CLEANING

Use general cleaning methods to clean all parts (page 2-30).

INSPECTION

Inspect all parts for wear or damage.

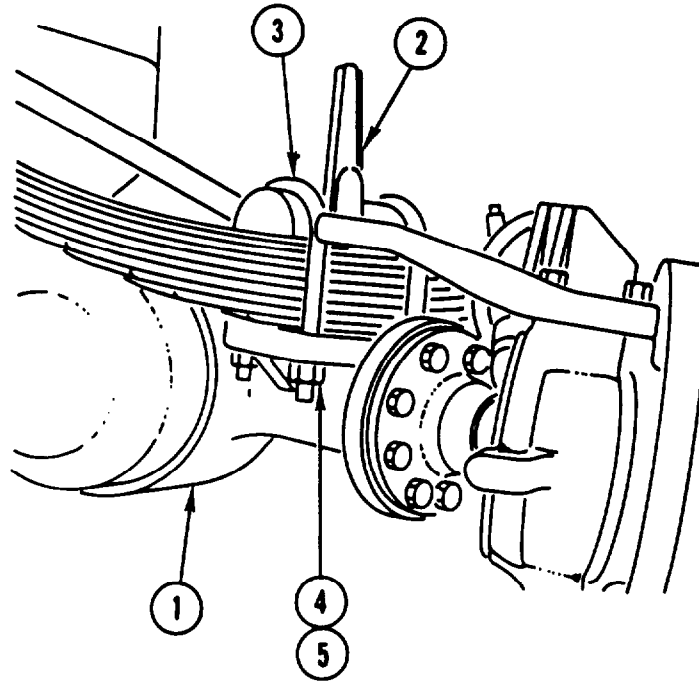
INSTALLATION**WARNING**

Front axle weighs 1,850 lb (839 kg). Support front axle with suitable floor jack during installation to prevent possible injury to personnel.

NOTE

- If axle housing was replaced, install front differential carrier assembly (page 5-34).
 - Procedure is the same for both sides except where noted.
1. USING SUITABLE FLOOR JACK UNDER EACH END OF AXLE (1), POSITION AXLE (1) UNDER VEHICLE.
 2. COAT BOTTOM AND U-BOLT SADDLES OF AXLE STOP (2) WITH ALUMILASTIC.
 3. INSTALL AXLE (1), AXLE STOP (2), TWO U-BOLTS (3), FOUR WASHERS (4), AND FOUR NUTS (5). TIGHTEN NUTS TO 380-460 LB-FT (515-624 N.m).

FRONT AXLE REPLACEMENT (CONT)

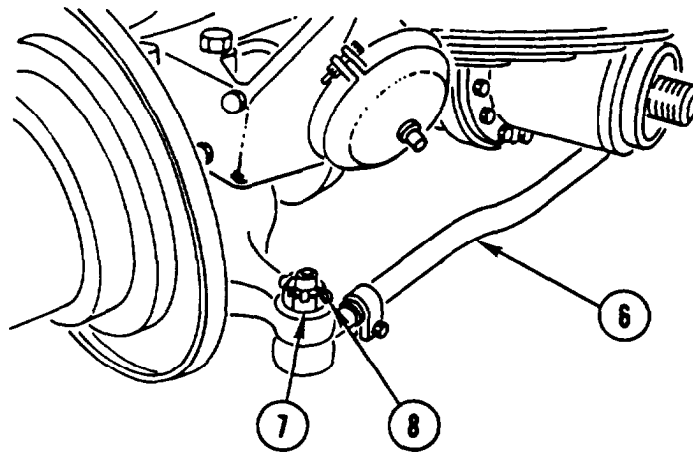

4. INSTALL TIE ROD (6) AND CASTELLATED NUT (7). TIGHTEN NUT TO 165-180 LB-FT (224-244 N.m).
5. INSTALL NEW COTTER PIN (8).

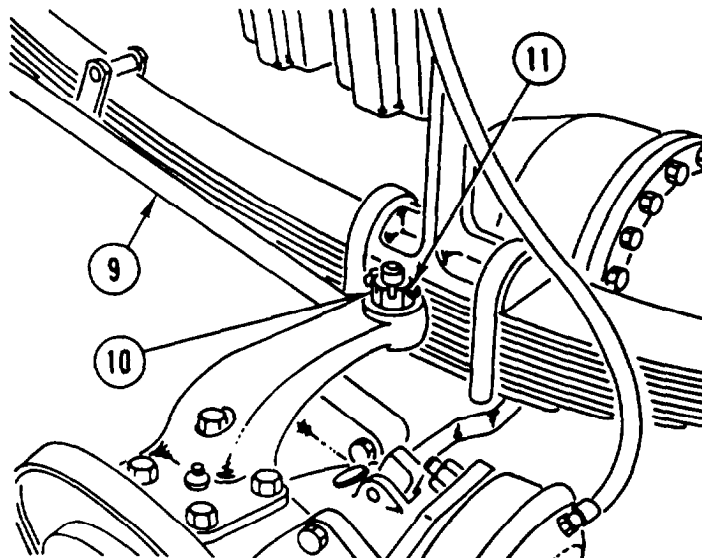

6. ON LEFT SIDE, INSTALL DRAG LINK (9) AND CASTELLATED NUT (10). TIGHTEN NUT TO 165-180 LB-FT (224-244 N.m).
7. INSTALL NEW COTTER PIN (11).

NOTE

Follow-on Maintenance:

- Install front brake spider and brake chamber bracket (TM 9-2320-363-20).
- Install driveline (TM 9-2320-363-20).
- Fill axle with oil (TM 9-2320-363-20).
- Check front axle caster alignment (page 5-60).

FRONT AXLE SHAFT REPLACEMENT AND REPAIR

This task covers: a. Removal b. Disassembly c. Cleaning d. Inspection e. Repair
f. Assembly g. Installation

INITIAL SETUP

Applicable Configuration:

All except M915A2

Tools and Special Equipment:

Shop Equipment, SC 4910-95-CL-A31
Tool Kit, SC 5180-90-CL-N05

Materials/Parts:

Ring, Seal P/N 2034370

Washer, Lock (2)

Grease, Automotive and Artillery (GAA) Appendix B, Item 26

Oil, Lubricating Gear Appendix B, Item 37

Adhesive-Sealant, Silicone Appendix B, Item 3

Loctite® 242 Appendix B, Item 33

References:

TM 9-2320-363-20

Equipment Condition:

Reference	Condition	Description
TM 9-2320-363-20	Axle Oil Drained	
TM 9-2320-363-20	Front Slack Adjuster and S-Cam Removed	

General Safety Instructions:

WARNING

Adhesives, solvents, and sealant compounds can burn easily, can give off harmful vapors, and are harmful to skin and clothing. To avoid injury or death, keep away from open fire and use in well-ventilated area. If adhesive, solvent, or sealant compound gets on skin or clothing, wash immediately with soap and water.

FRONT AXLE SHAFT REPLACEMENT AND REPAIR (CONT)

REMOVAL

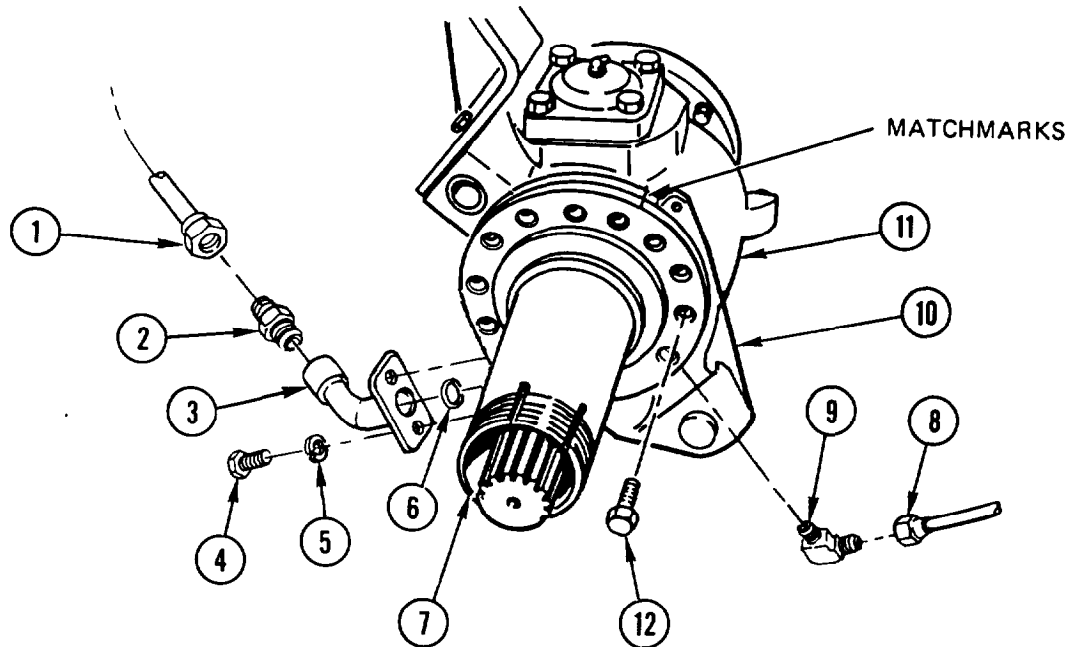

NOTE

- Procedure is the same for both right and left axle shafts and cage ring assemblies. Right side is shown.
- Perform steps 1 thru 3 for M917A1 and M917A1 w/MCS.

1. DISCONNECT CTIS TUBE (1) FROM ADAPTER (2) AND REMOVE ADAPTER FROM MANIFOLD BLOCK (3).
2. REMOVE TWO SCREWS (4), LOCK WASHERS (5), MANIFOLD BLOCK (3) AND SEAL RING (6) FROM SKEIN (7). DISCARD LOCK WASHERS AND SEAL RING.
3. DISCONNECT CTIS VENT TUBE (8) FROM ELBOW (9) AND REMOVE ELBOW FROM SKEIN (7).
4. MATCHMARK AXLE SKEIN (7), BRAKE SPIDER (10), AND BALL SOCKET (11).
5. REMOVE 10 CAPSCREWS (12) FROM AXLE SKEIN (7), BRAKE SPIDER (10), AND BALL SOCKET (11).

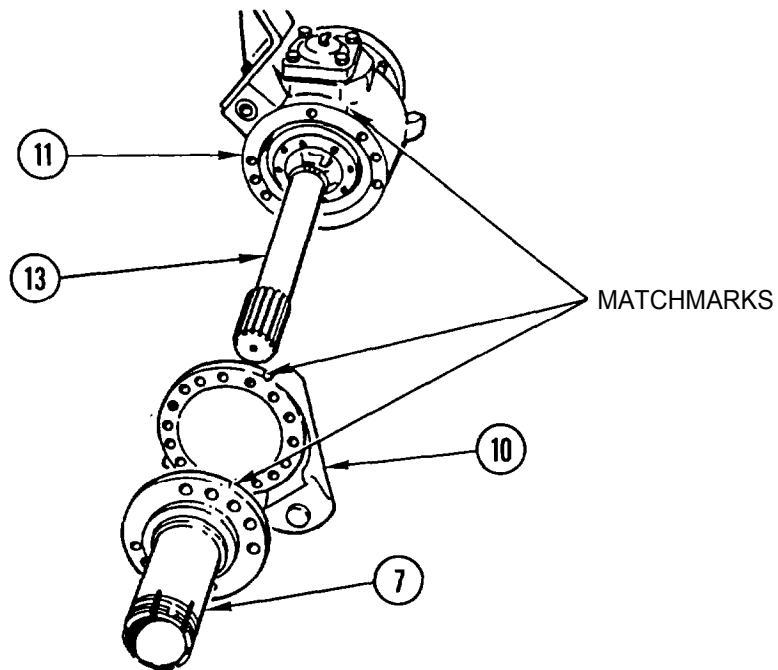

NOTE

Provide suitable container to catch grease that will come out of axle.

6. REMOVE AXLE SKEIN (7) AND BRAKE SPIDER (10) FROM AXLE SHAFT ASSEMBLY (13).
7. REMOVE BRAKE SPIDER (10) FROM AXLE SKEIN (7).
8. REMOVE AXLE SHAFT ASSEMBLY (13) FROM BALL SOCKET (11).

DISASSEMBLY

NOTE

Before splitting cage ring, mark axle shafts and cage ring halves to ensure correct assembly. Axle shaft yoke trunnion must be replaced in same cage ring holes.

1. MATCHMARK BOTH HALVES OF CAGE RING (1).

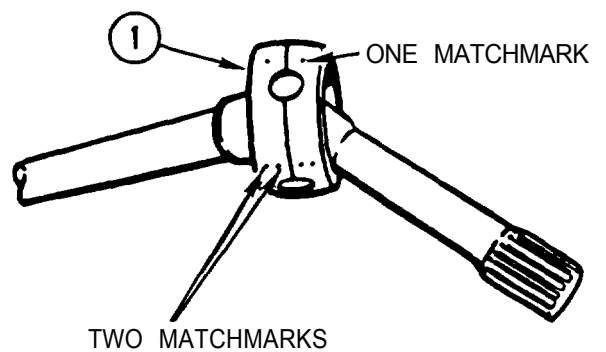

FRONT AXLE SHAFT REPLACEMENT AND REPAIR (CONT)

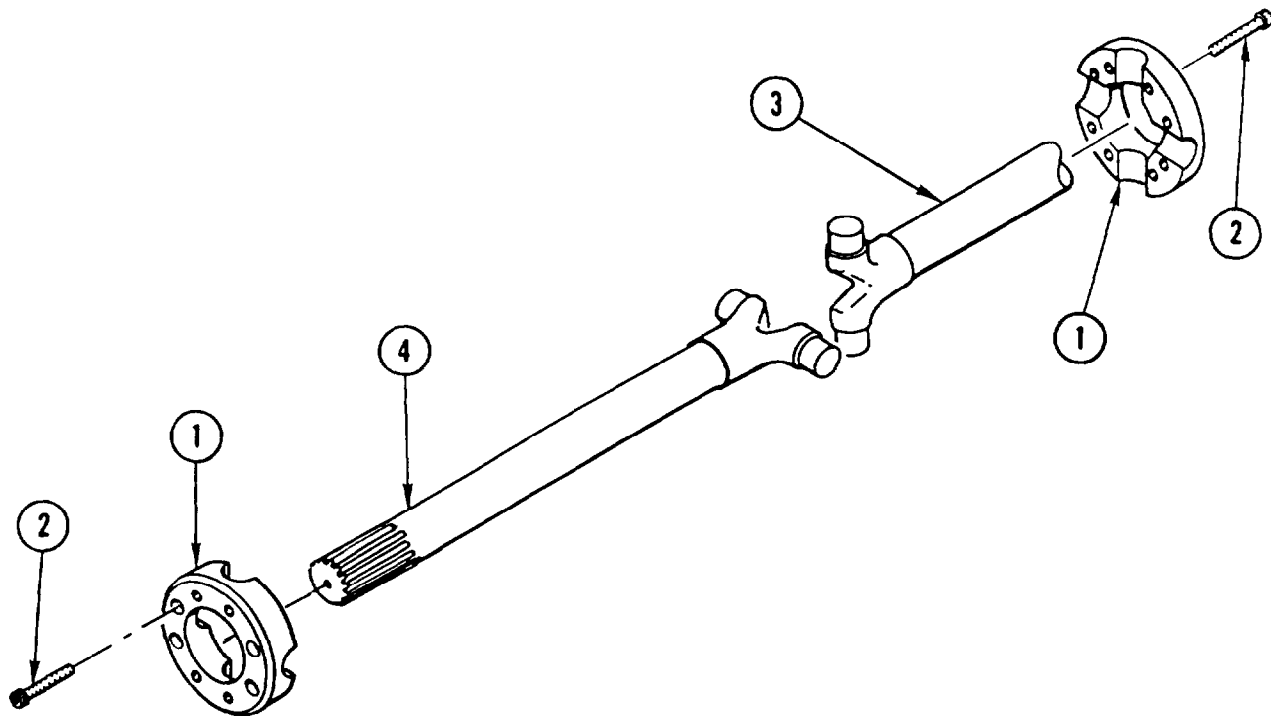

2. REMOVE EIGHT SOCKET HEAD SCREWS (2) FROM TWO CAGE RING HALVES (1).
3. REMOVE TWO CAGE RING HALVES (1) FROM TWO SHAFTS (3 AND 4).

CLEANING

Use general cleaning methods to clean all parts (page 2-30).

INSPECTION

1. INSPECT ALL PARTS FOR WEAR OR DAMAGE.
2. INSTALL EIGHT SOCKET HEAD SCREWS (2) IN TWO CAGE RING HALVES (1) AND TIGHTEN SCREWS TO 30 LB-FT (41 N.m).
3. MEASURE INSIDE DIAMETER OF SHAFT HOLES IN TWO CAGE RING HALVES (1) AND OUTSIDE DIAMETER OF YOKES ON TWO SHAFTS (3 AND 4). IF DIFFERENCE IS MORE THAN 0.20 IN. (5.08 mm), REPLACE TWO CAGE RING HALVES (1) AND TWO SHAFTS (3 AND 4).
4. REMOVE EIGHT SOCKET HEAD SCREWS (2) FROM TWO CAGE RING HALVES (1).

REPAIR

Use general repair methods to repair damaged parts (page 2-33).

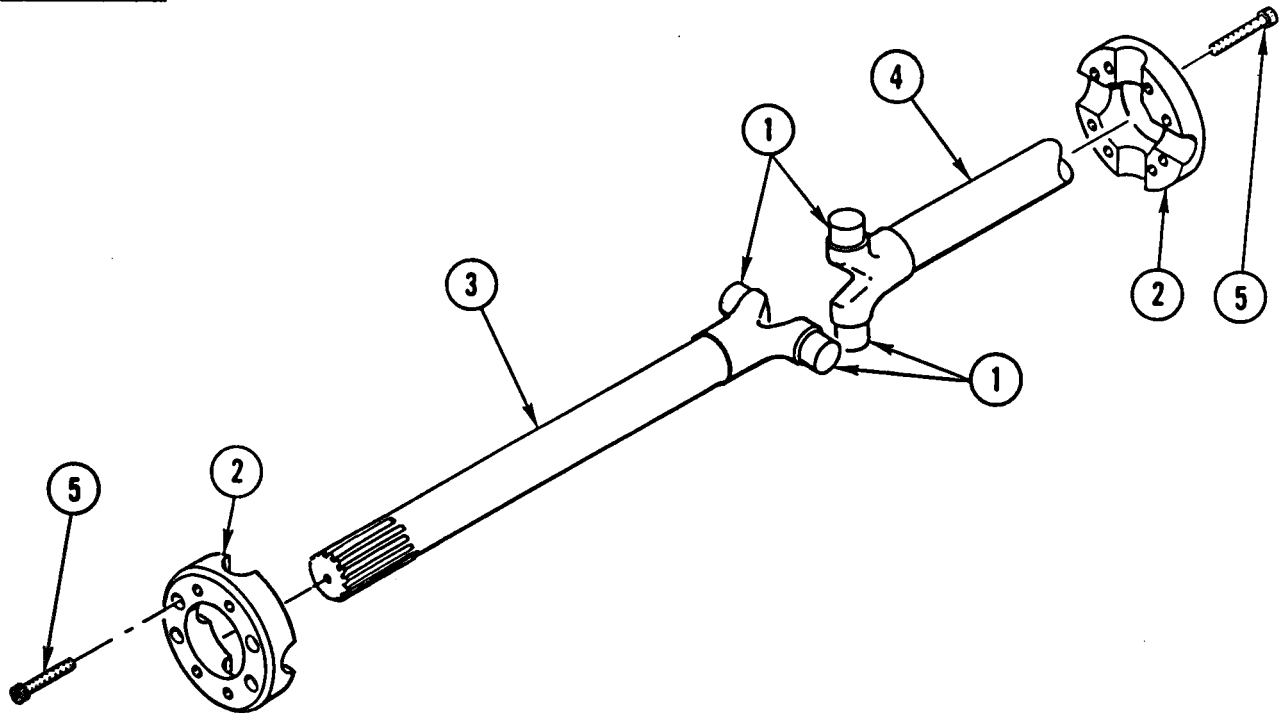
ASSEMBLY

1. APPLY LIGHT COAT OF GREASE TO FOUR TRUNNIONS (1) AND TWO CAGE RING HALVES (2).
2. ALINE MATCHMARKS AND INSTALL TWO CAGE RING HALVES (2) ON TWO SHAFTS (3 AND 4).
3. INSTALL EIGHT SOCKET HEAD SCREWS (5). DO NOT TIGHTEN SCREWS.
4. MOVE TWO SHAFTS (3 AND 4) TO CHECK FOR FREE SIDE-TO-SIDE MOVEMENT INSIDE TWO CAGE RING HALVES (2).
5. TIGHTEN EIGHT SOCKET HEAD SCREWS (5) TO 95 LB-FT (129 N.m).

FRONT AXLE SHAFT REPLACEMENT AND REPAIR (CONT)

INSTALLATION

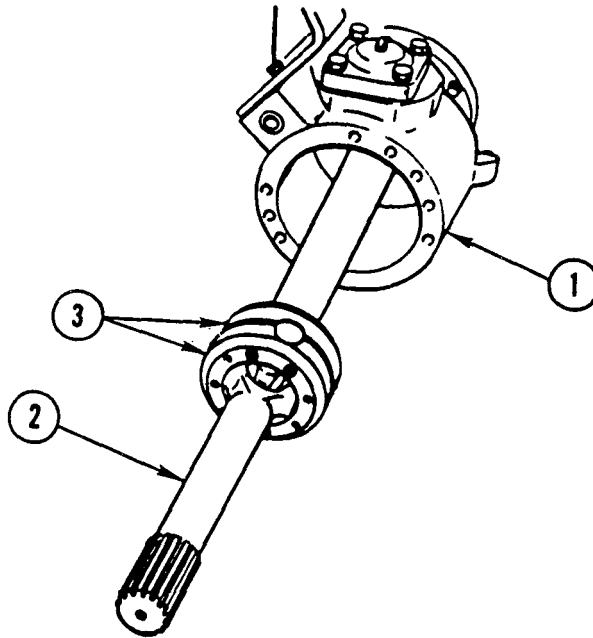

NOTE

Procedure is the same for both right and left axle shafts and cage ring assemblies. Right side is shown.

1. TURN BALL SOCKET (1) TO STRAIGHT-AHEAD POSITION.
2. APPLY THIN COAT OF OIL TO POLISHED SURFACES OF AXLE SHAFT ASSEMBLY (2).
3. PACK CAGE RING (3) WITH GREASE.

CAUTION

Take care not to damage axle housing oil seal when installing axle shaft.

4. INSTALL AXLE SHAFT ASSEMBLY (2) IN BALL SOCKET (1) LONG END FIRST.
5. FILL BALL SOCKET (1) AND CAGE RING (3) WITH GREASE.

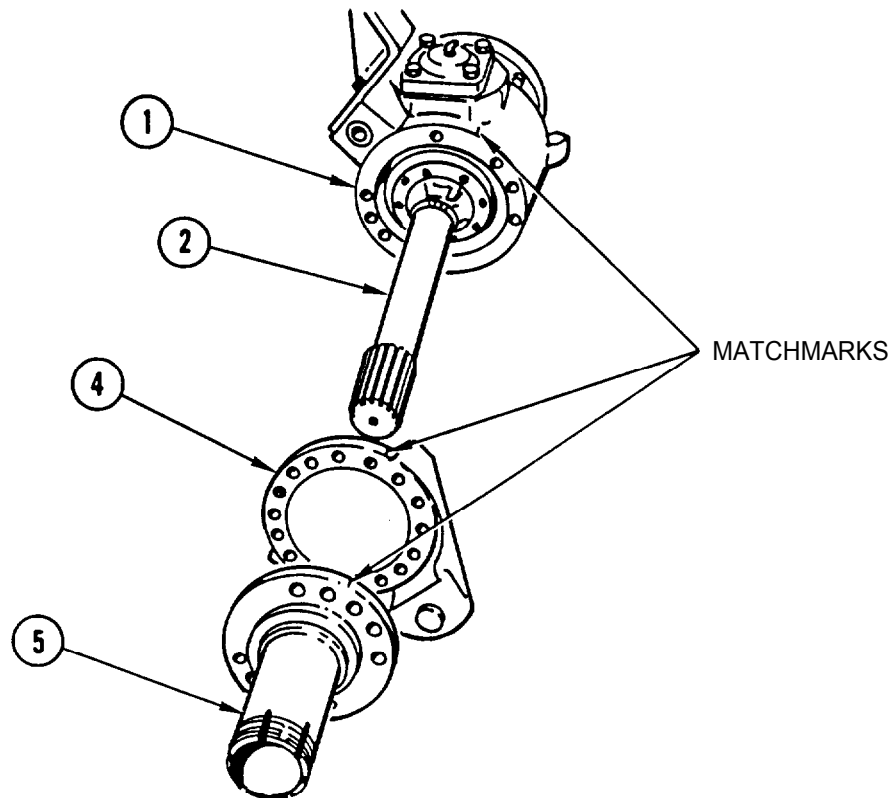

WARNING

Adhesives, solvents, and sealant compounds can burn easily, can give off harmful vapors, and are harmful to skin and clothing. To avoid injury or death, keep away from open fire and use in well-ventilated area. If adhesive, solvent, or sealant compound gets on skin or clothing, wash immediately with soap and water.

6. APPLY THIN COAT OF SILICONE ADHESIVE-SEALANT TO BOTH SIDES OF BRAKE SPIDER (4) AND AXLE SKEIN (5).
7. ALINE MATCHMARKS ON BRAKE SPIDER (4) WITH MATCHMARKS ON AXLE SKEIN (5).
8. INSTALL BRAKE SPIDER (4) AND AXLE SKEIN (5) OVER AXLE SHAFT ASSEMBLY (2).
9. ALINE MATCHMARKS ON BRAKE SPIDER (4) AND AXLE SKEIN (5) WITH MATCHMARKS ON BALL SOCKET (1).

FRONT AXLE SHAFT REPLACEMENT AND REPAIR (CONT)

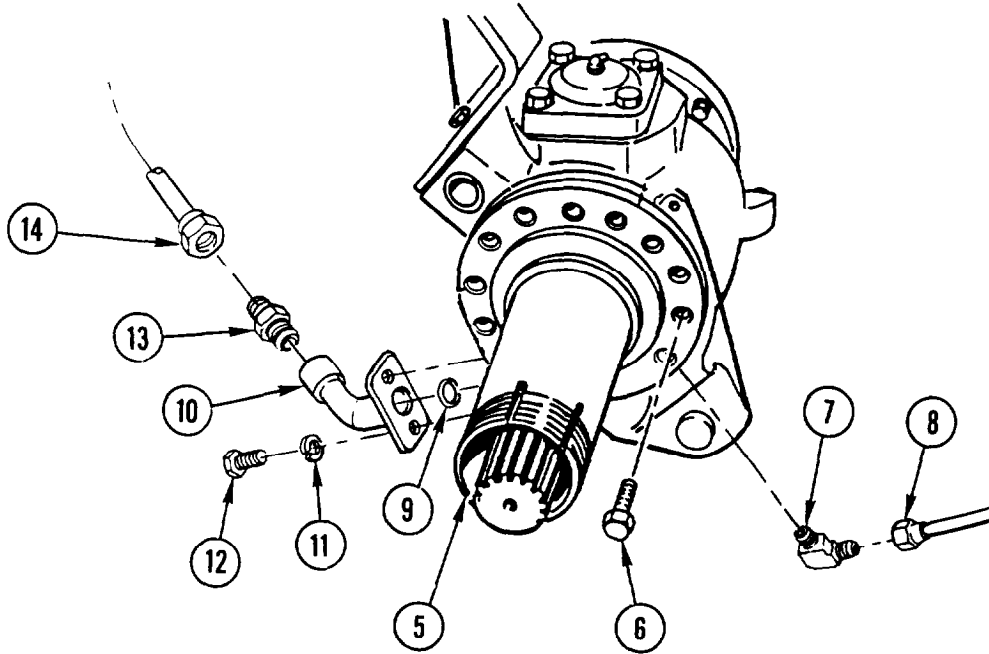

10. APPLY SILICONE ADHESIVE-SEALANT TO UNDERSIDE OF HEADS OF 10 CAPSCREWS (6) AND APPLY LOCTITE ® 242 TO THREADS OF CAPSCREWS.
11. INSTALL 10 CAPSCREWS (6) AND TIGHTEN TO 185-190 LB-FT (251-257 N.m).
12. APPLY THIN COAT OF GREASE TO BEARING AND SEAL SURFACES OF AXLE SKEIN (5).

NOTE

Perform steps 13 thru 15 for M917A1 and M917A1 w/MCS.

13. INSTALL ELBOW (7) TO SKEIN (5) AND CONNECT CTIS VENT TUBE (8).
14. INSTALL NEW SEAL RING (9) AND MANIFOLD BLOCK (10) TO SKEIN (5) WITH TWO NEW LOCK WASHERS (11) AND SCREWS (12).
15. INSTALL ADAPTER (13) TO MANIFOLD BLOCK (10) AND CONNECT CTIS TUBE (14).

NOTE

Follow-on Maintenance:

Install front slack adjuster and S-cam (TM 9-2320-363-20).
Fill axle with oil (TM 9-2320-363-20).

FRONT BALL SOCKET REPLACEMENT

This task covers: a. Removal b. Cleaning c. Inspection d. Repair e. Installation

INITIAL SETUP

Applicable Configuration:

All except M915A2

Tools and Special Equipment:

Shop Equipment, SC 4910-95-CL-A31

Tool Kit, SC 5180-90-CL-N05

Spring Scale, J8129

Materials/Parts:

Seal P/N 1391490

Washer, Lock (20)

Washer, Lock (8)

Washer, Lock (8) P/N 318BX

Grease, Automotive and Artillery (GAA) Appendix B, Item 26

Adhesive-Sealant, Silicone Appendix B, Item 3

Tag, Identification Appendix B, Item 55

References:

TM 9-2320-363-20

Equipment Condition:

Reference

Condition Description

TM 9-2320-363-20

Front Air Brake Chamber Removed

TM 9-2320-363-20

Front Slack Adjuster and S-Cam Removed

Page 5-52

Tie Rod Removed

Page 5-7

Front Axle Shaft Removed

General Safety Instructions:

WARNING

Adhesives, solvents, and sealant compounds can burn easily, can give off harmful vapors, and are harmful to skin and clothing. To avoid injury or death, keep away from open fire and use in well-ventilated area. If adhesive, solvent, or sealant compound gets on skin or clothing, wash immediately with soap and water.

FRONT BALL SOCKET REPLACEMENT (CONT)

REMOVAL

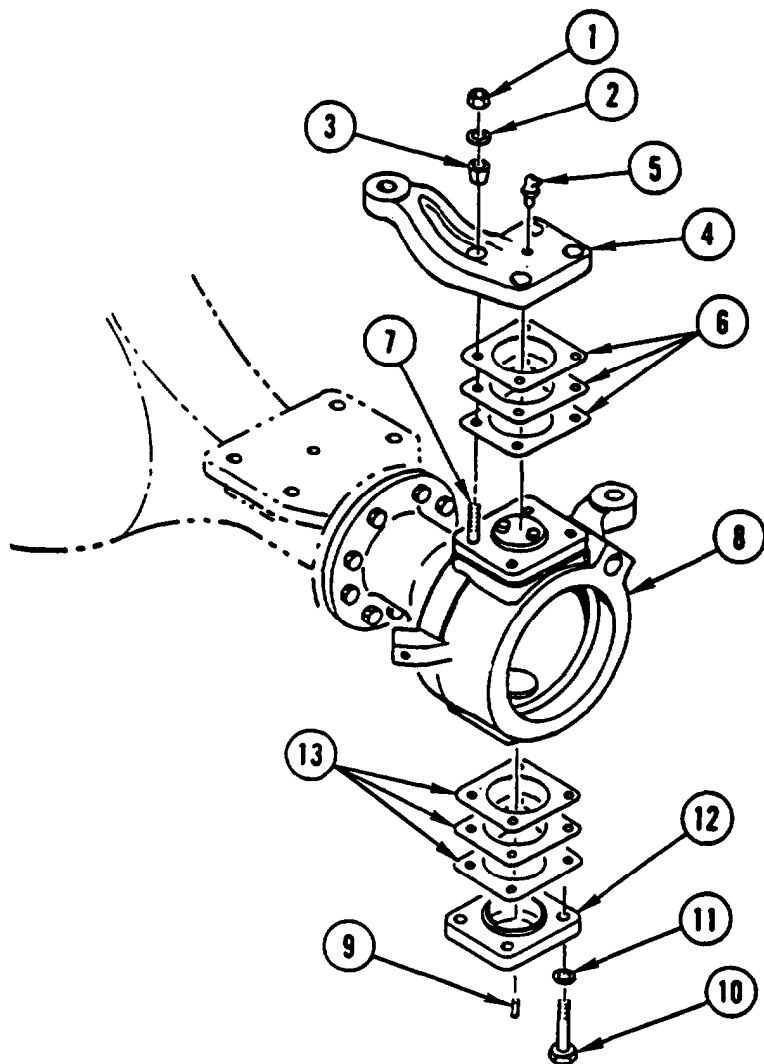

1. REMOVE FOUR NUTS (1), FOUR LOCK WASHERS (2), FOUR DOWELS (3), AND STEERING ARM (4). DISCARD LOCK WASHERS.
2. IF DAMAGED, REMOVE GREASE FITTING (5).
3. RECORD NUMBER AND THICKNESS OF SHIMS (6). REMOVE SHIMS (6) FROM STUDS (7) ON LEFT BALL SOCKET (8).

NOTE

Steps 4 and 5 are for both left and right sides.

4. REMOVE PIPE PLUG (9).
5. REMOVE FOUR SCREWS (10), FOUR LOCK WASHERS (11), BOTTOM COVER (12), AND SHIMS (13) FROM BALL SOCKET (8). RECORD NUMBER AND THICKNESS OF SHIMS (13). DISCARD LOCK WASHERS.

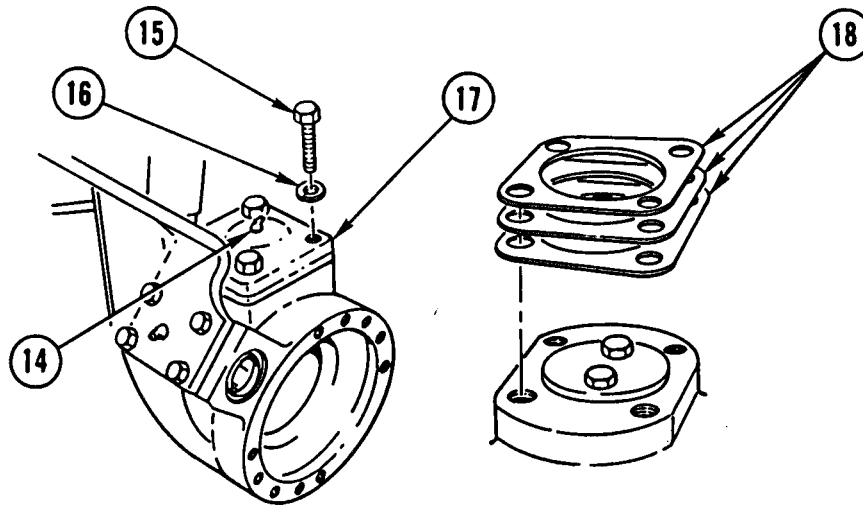

NOTE

Steps 6 thru 8 are for right side only.

6. IF DAMAGED, REMOVE GREASE FITTING (14).
7. REMOVE FOUR SCREWS (15), FOUR LOCK WASHERS (16), AND TOP COVER (17). DISCARD LOCK WASHERS.
8. RECORD NUMBER AND THICKNESS OF SHIMS (18). REMOVE SHIMS (18).

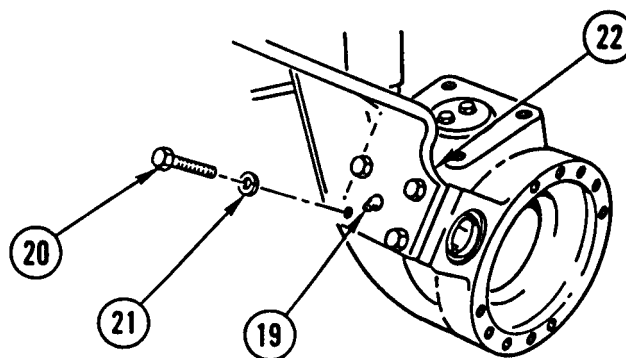

NOTE

Steps 9 thru 24 are for both left and right sides.

9. IF DAMAGED, REMOVE GREASE FITTING (19).
10. REMOVE FOUR SCREWS (20) AND FOUR LOCK WASHERS (21). DISCARD LOCK WASHERS.
11. REMOVE BRAKE CHAMBER MOUNTING BRACKET (22).

FRONT BALL SOCKET REPLACEMENT (CONT)

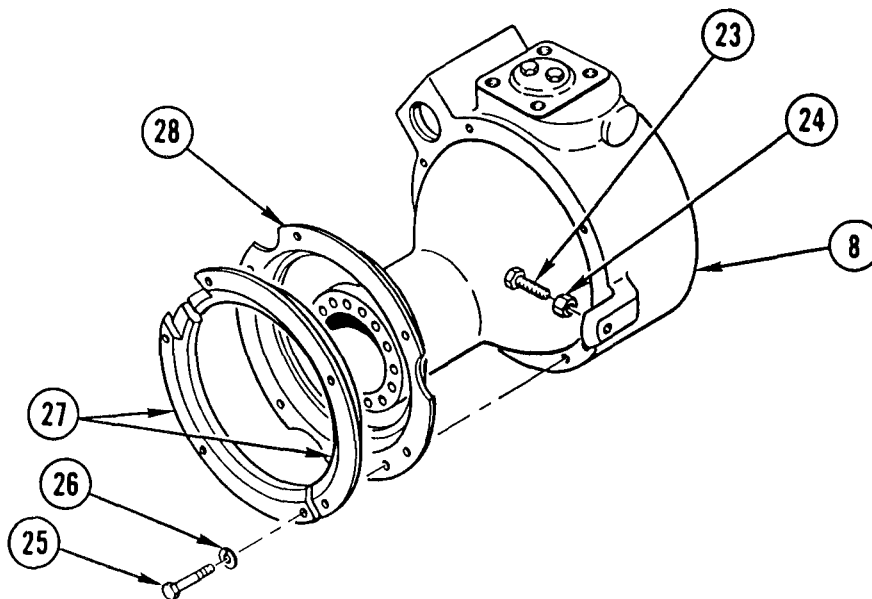

12. MEASURE AND RECORD LENGTH FROM TOP OF STOP BOLT (23) TO TOP OF NUT (24).
13. REMOVE NUT (24) AND STOP BOLT (23) FROM BALL SOCKET (8).
14. REMOVE SIX SCREWS (25) AND SIX LOCK WASHERS (26), DISCARD LOCK WASHERS.
15. REMOVE SEAL RETAINER HALVES (27) AND SEAL (28) FROM BALL SOCKET (8).

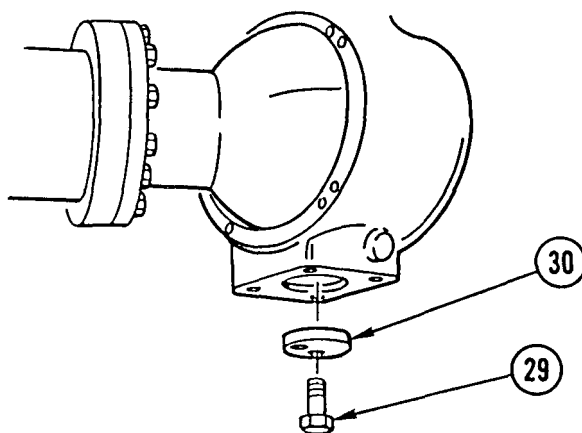

16. REMOVE TWO SCREWS (29) AND END PLATE (30).

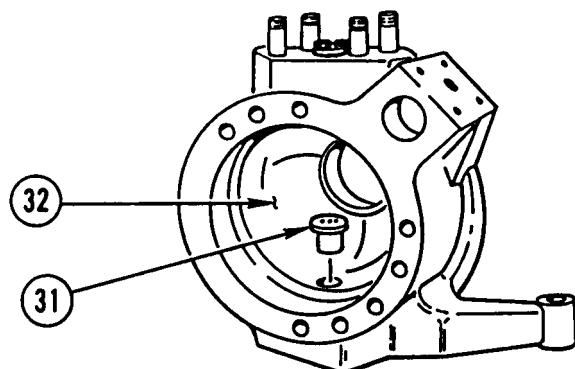

17. REMOVE LOWER AXLE BALL TRUNNION (31) BY DRIVING LOWER AXLE BALL TRUNNION (31) UP INTO BALL AND BUSHING ASSEMBLY (32).

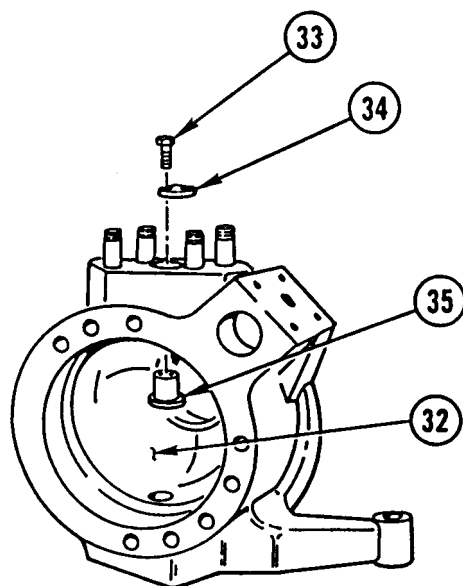

18. REMOVE TWO SCREWS (33) AND END PLATE (34) FROM UPPER AXLE BALL TRUNNION (35).
19. REMOVE UPPER AXLE BALL TRUNNION (35) BY DRIVING UPPER AXLE BALL TRUNNION (35) DOWN INTO BALL AND BUSHING ASSEMBLY (32).

FRONT BALL SOCKET REPLACEMENT (CONT)

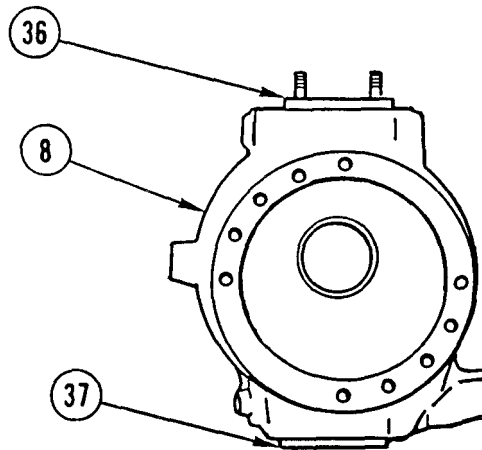

CAUTION

Use sledgehammer carefully. Hammering too hard can crack ball socket or damage trunnion bearings if they are not seated before hammering.

20. HAMMER AROUND TOP OF BALL SOCKET (8) UNTIL UPPER AND LOWER BEARING CUPS (36 AND 37) ARE 1/8 IN. (3.18 mm) ABOVE AND BELOW BALL SOCKET (8) SURFACE.

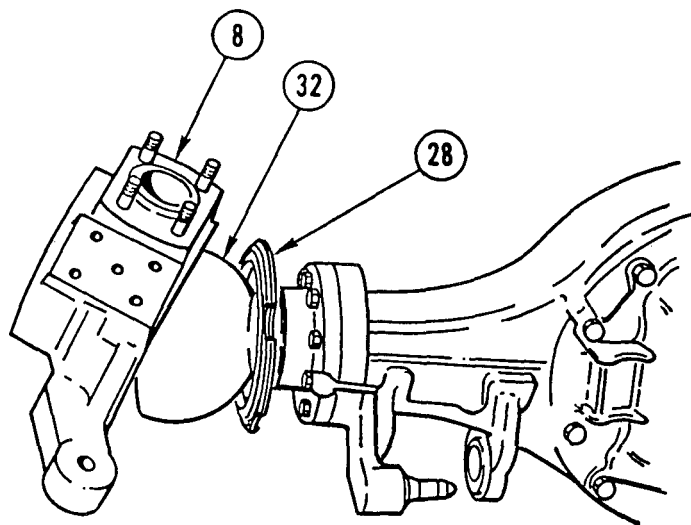

21. TIP BALL SOCKET (8) OUT AND UP FROM BOTTOM AND REMOVE FROM BALL AND BUSHING ASSEMBLY (32).
22. REMOVE AND DISCARD SEAL (28) FROM BALL AND BUSHING ASSEMBLY (32).

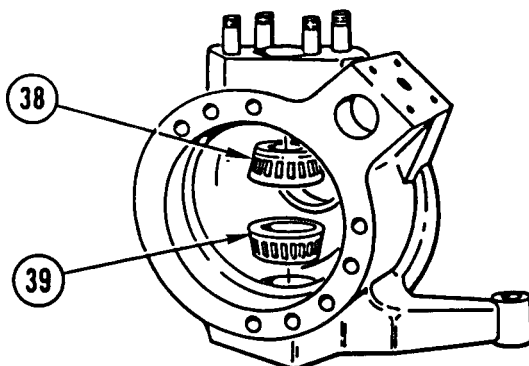

NOTE

Upper and lower bearings and bearing cups are matched sets. Tag prior to removal to aid in installation.

23. REMOVE BEARINGS (38 AND 39).

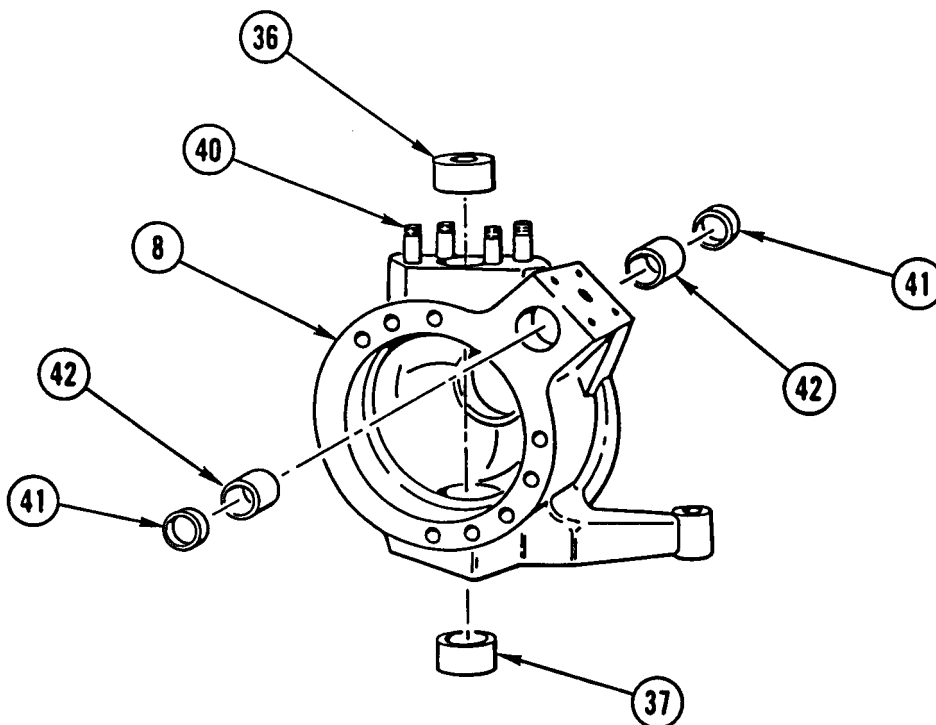

24. REMOVE UPPER AND LOWER BEARING CUPS (36 AND 37) FROM BALL SOCKET (8).

25. IF DAMAGED, REMOVE FOUR STUDS (40) FROM BALL SOCKET (8) ON LEFT SIDE ONLY.

26. REMOVE TWO SEALS (41) AND TWO BUSHINGS (42) ON RIGHT AND LEFT SIDES.

FRONT BALL SOCKET REPLACEMENT (CONT)

CLEANING

Use general cleaning methods to clean all parts (page 2-30).

INSPECTION

1. INSPECT ALL PARTS FOR WEAR OR DAMAGE.
2. INSPECT BUSHINGS FOR OUT-OF-ROUND CONDITION. REPLACE BUSHINGS IF 0.005 IN. (1.270 mm) OR MORE OUTOF ROUND.

REPAIR

Use general repair methods to repair damaged parts (page 2-33).

INSTALLATION

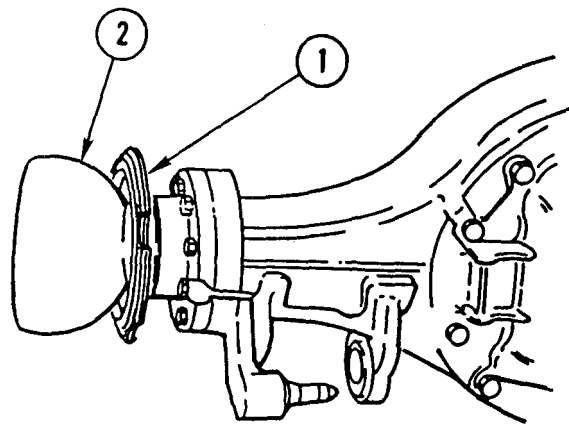

NOTE

Steps 1 thru 3 are for both left and right ball sockets. Left side is shown.

1. INSTALL NEW SEAL (1) OVER BALL AND BUSHING ASSEMBLY (2).

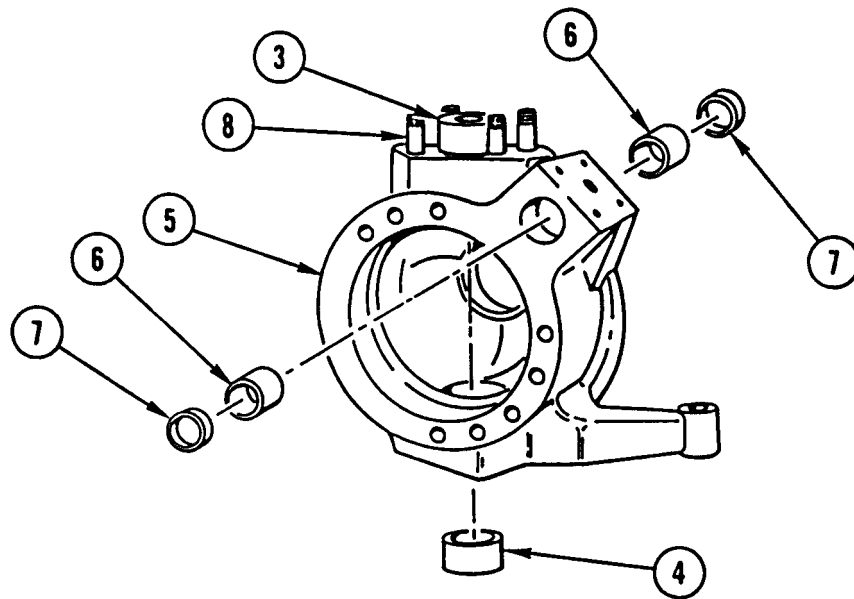

NOTE

Top bearing cup has small opening up and bottom bearing cup has small opening down.

2. INSTALL BEARING CUPS (3 AND 4) IN BALL SOCKET (5). TAP BEARING CUPS (3 AND 4) UNTIL BEARING CUPS ARE NOT MORE THAN 1/8 IN. (3.18 mm) ABOVE BALL SOCKET (5).
3. INSTALL TWO BUSHINGS (6) AND TWO SEALS (7) IN BALL SOCKET (5).
4. IF REMOVED, INSTALL FOUR STUDS (8) IN LEFT BALL SOCKET (5).

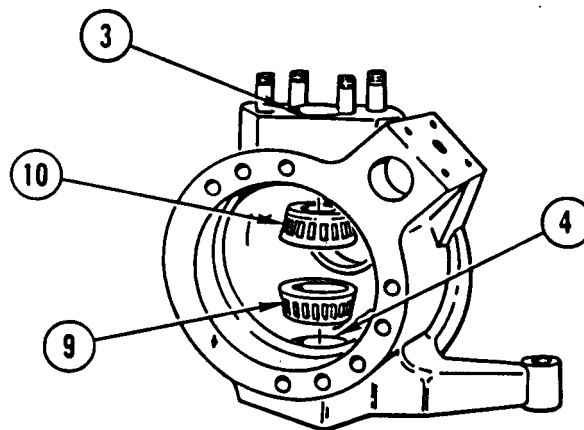

NOTE

Steps 5 thru 18 are for both sides.

5. PACK LOWER BEARING (9) WITH GREASE AND INSTALL IN BEARING CUP (4).
6. PACK UPPER BEARING (10) WITH GREASE AND INSTALL IN BEARING CUP (3).

FRONT BALL SOCKET REPLACEMENT (CONT)

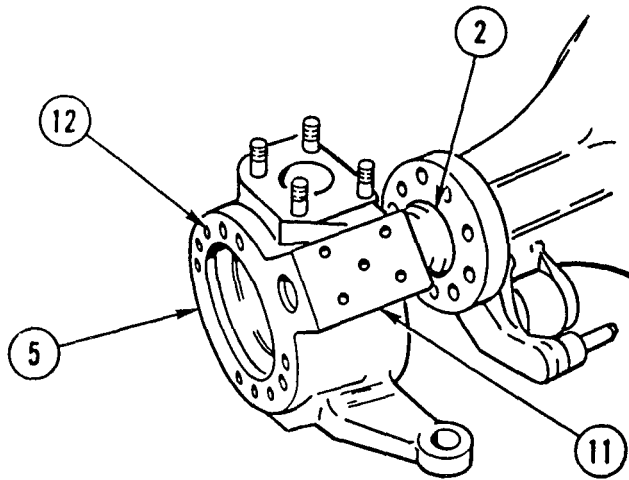

7. WITH BRAKE CHAMBER MOUNTING SURFACE (11) FACING TO REAR AND MOUNTING HOLES (12) FACING OUT, INSTALL BALL SOCKET (5) OVER BALL AND BUSHING ASSEMBLY (2).

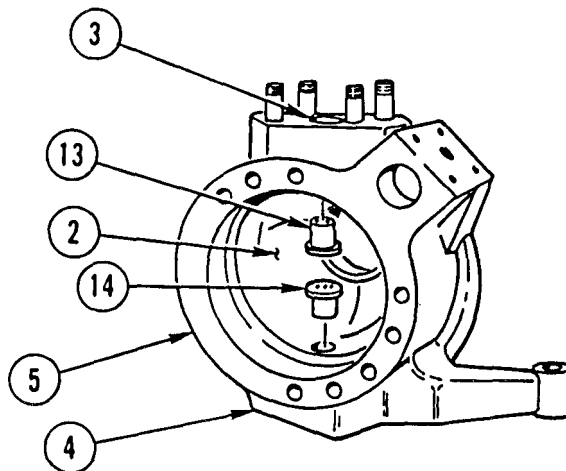

8. ALINE BALL SOCKET (5) WITH TRUNNION HOLES IN BALL AND BUSHING ASSEMBLY (2) AND INSTALL AXLE BALL TRUNNIONS (13 AND 14).
9. DRIVE BEARING CUPS (3 AND 4) FLUSH WITH SURFACE OF BALL AND BUSHING ASSEMBLY (2).

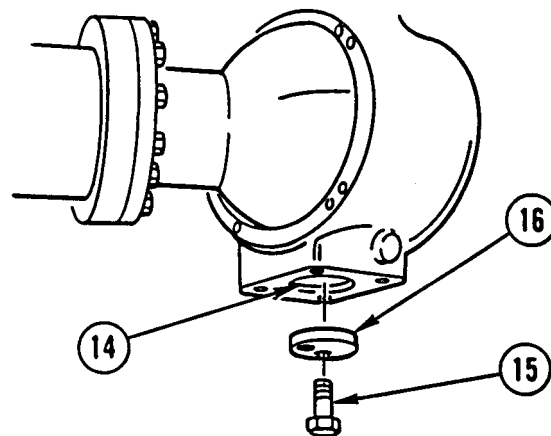

10. APPLY LIGHT COAT OF GREASE TO THREADS OF TWO SCREWS (15).
11. INSTALL END PLATE (16) AND TWO SCREWS (15) ON LOWER AXLE BALL TRUNNION (14). TIGHTEN SCREWS TO 40 LB-FT (54 N.m).

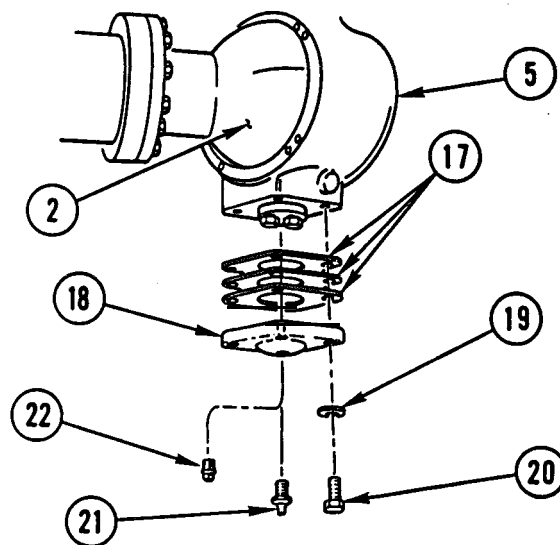

NOTE

Install same number and thickness of shims as removed.

12. INSTALL SHIMS (17), BOTTOM COVER (18), FOUR NEW LOCK WASHERS (19), AND FOUR SCREWS (20). TIGHTEN SCREWS TO 185 LB-FT (251 N.m).
13. INSTALL GREASE FITTING (21) IN BOTTOM COVER (18).
14. APPLY GREASE TO LOWER BEARING AT GREASE FITTING (21).
15. REMOVE GREASE FITTING (21).
16. INSTALL PIPE PLUG (22).
17. APPLY GREASE TO BALL AND BUSHING ASSEMBLY (2) AT REAR OF BALL SOCKET (5).

FRONT BALL SOCKET REPLACEMENT (CONT)

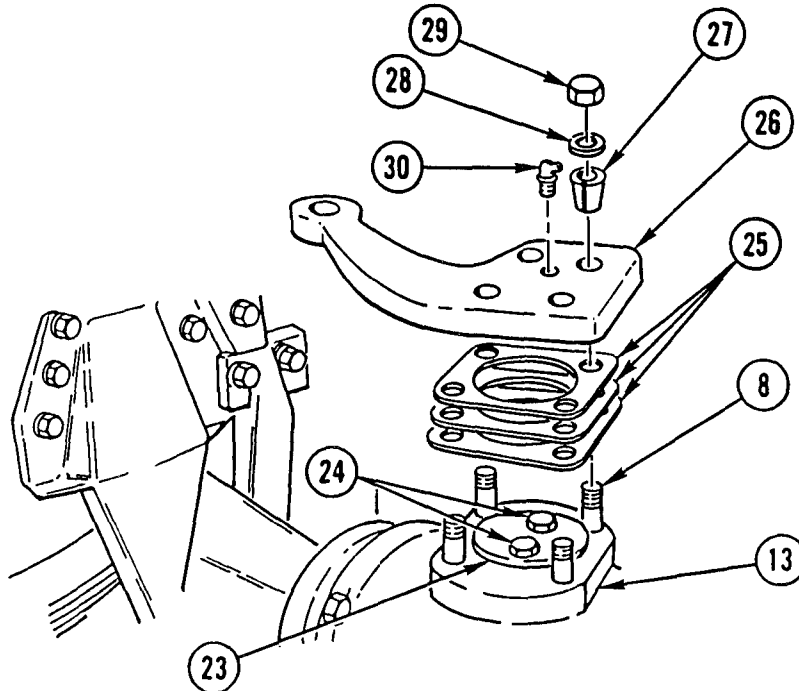

18. INSTALL END PLATE (23) AND TWO SCREWS (24) ON UPPER AXLE BALL TRUNNION (13). TIGHTEN SCREWS TO 40 LB-FT (54 N.m).

NOTE

- Steps 19 thru 23 are for left side only.
- Install same number and thickness of shims as removed.

19. INSTALL SHIMS (25) ON FOUR STUDS (8).

NOTE

Install steering arm with flange side down.

20. INSTALL STEERING ARM (26) ON FOUR STUDS (8).
21. INSTALL ONE DOWEL (27) ON EACH OF FOUR STUDS (8).
22. INSTALL FOUR NEW LOCK WASHERS (28) AND FOUR NUTS (29) ON STEERING ARM (26). TIGHTEN NUTS TO 35-40 LB-FT (47-54 N.m).
23. IF REMOVED, INSTALL NEW GREASE FITTING (30).
24. APPLY COAT OF GREASE TO UPPER BEARING AT GREASE FITTING (30).

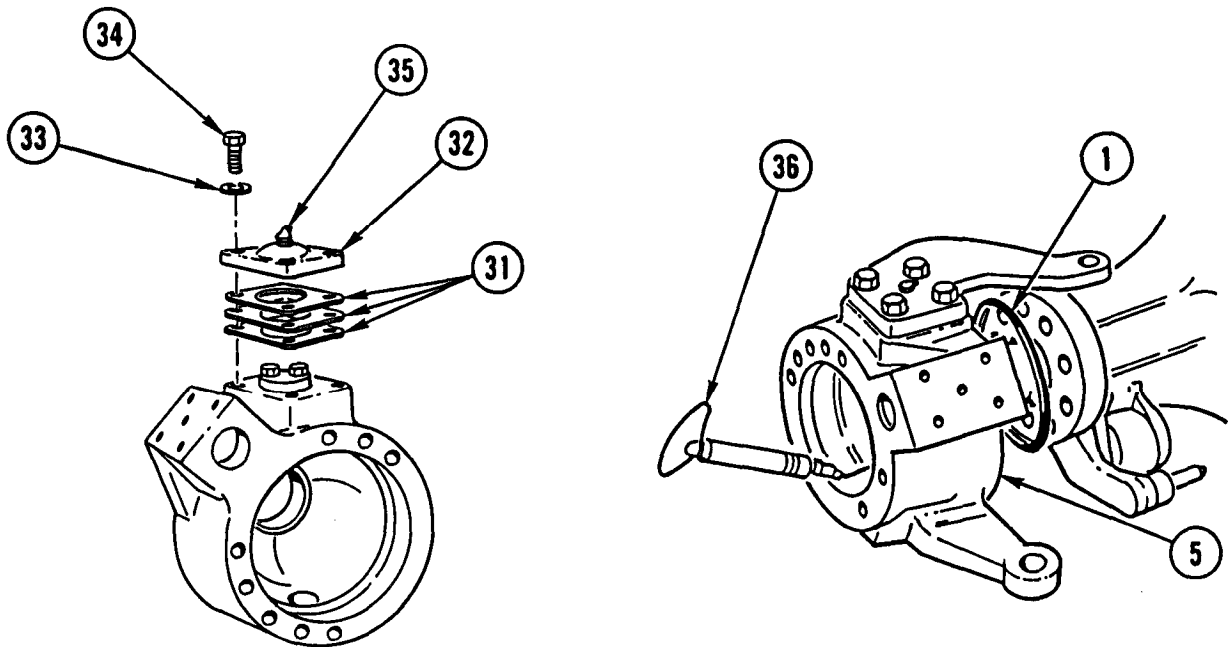

NOTE

- Steps 25 thru 27 are for right side only.
- Install same number and thickness of shims as removed.

25. INSTALL SHIMS (31), TOP COVER (32), FOUR NEW LOCK WASHERS (33), AND FOUR SCREWS (34). TIGHTEN SCREWS TO 185-190 LB-FT (251-258 N.m).
26. IF REMOVED, INSTALL NEW GREASE FITTING (35).
27. APPLY GREASE TO UPPER AXLE BALL TRUNNION THRU GREASE FITTING (35).
28. HOOK SPRING SCALE (36) ON END OF BALL SOCKET (5).
29. PULL SPRING SCALE (36) AND CHECK THAT BALL SOCKET (5) WILL MOVE WITH PULL OF 35-45 LB (16-20 kg); GO TO STEP 32. IF LESS THAN 35 LB (16 kg) IS REQUIRED, GO TO STEP 30. IF MORE THAN 45 LB (20 kg) IS REQUIRED, GO TO STEP 31.
30. RECORD NUMBER AND THICKNESS OF SHIMS (31) AND REMOVE ONE SHIM, SAME THICKNESS, FROM TOP AND BOTTOM OF BALL SOCKET (5). REPEAT STEP 29.
31. RECORD NUMBER AND THICKNESS OF SHIMS (31) AND ADD ONE SHIM, SAME THICKNESS, TO TOP AND BOTTOM OF BALL SOCKET (5). REPEAT STEP 29.
32. INSTALL SEAL (1) IN BALL SOCKET (5).

FRONT BALL SOCKET REPLACEMENT (CONT)

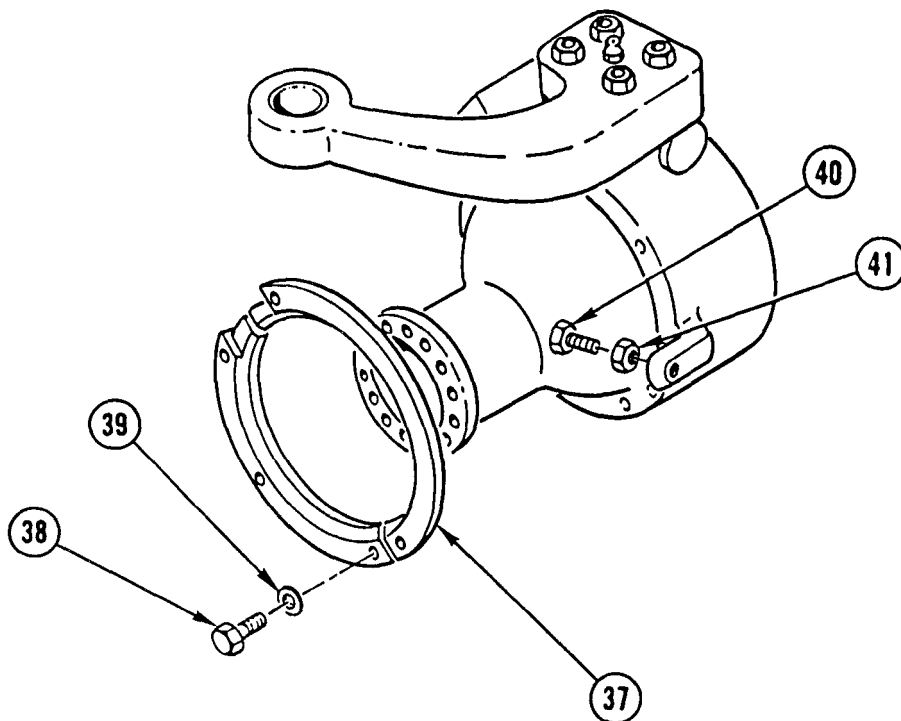

WARNING

Adhesives, solvents, and sealant compounds can burn easily, can give off harmful vapors, and are harmful to skin and clothing. To avoid injury or death, keep away from open fire and use in well-ventilated area. If adhesive, solvent, or sealant compound gets on skin or clothing, wash immediately with soap and water.

33. APPLY SILICONE ADHESIVE-SEALANT TO INNER SIDES OF SEAL RETAINER HALVES (37) AND SIX SCREWS (38).
34. APPLY SILICONE ADHESIVE-SEALANT BETWEEN SEAL RETAINER HALVES (37).
35. ALINE SEAL RETAINER HALVES (37) AND INSTALL SIX NEW LOCK WASHERS (39) AND SIX SCREWS (38). TIGHTEN SCREWS TO 25 LB-FT (34N.m).
36. INSTALL STEERING STOP BOLT (40) AND NUT (41) TO SAME MEASUREMENT AS RECORDED DURING REMOVAL.

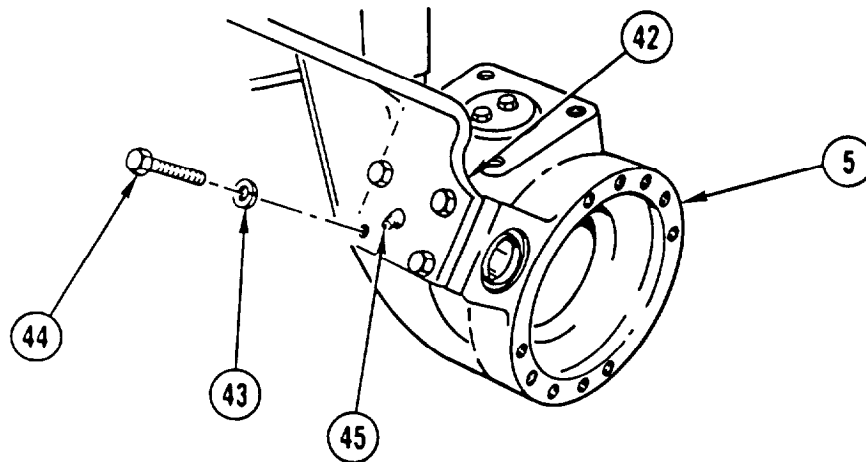

37. INSTALL BRAKE CHAMBER MOUNTING BRACKET (42) ON BALL SOCKET (5).
38. INSTALL FOUR NEW LOCK WASHERS (43) AND FOUR SCREWS (44).
39. IF REMOVED, INSTALL NEW GREASE FITTING (45).

NOTE

Follow-on Maintenance:

- Install front axle shaft (page 5-7).
- Install front slack adjuster and S-cam (TM 9-2320-363-20).
- Install front air brake chamber (TM 9-2320-363-20).
- Install tie rod (page 5-52).

FRONT BALL, BUSHING, AND OIL SEAL REPLACEMENT

This task covers: a. Removal b. Cleaning c. Inspection d. Installation

INITIAL SETUP

Applicable Configuration:

All except M915A2

Tools and Special Equipment:

Shop Equipment, SC 4910-95-CL-A31
 Tool Kit, SC 5180-90-CL-N05

Materials/Parts:

Seal, Oil P/N 53R012
 Adhesive-Sealant, Silicone Appendix B, Item 3

Personnel Required: (2)

Equipment Condition:

Reference	Condition	Description
Page 5-15	Front Ball Socket Removed	

General Safety Instructions:

WARNING

- Ball and bushing assembly is heavy and can injure personnel if dropped. Support ball and bushing assembly during removal or installation.
- Adhesives, solvents, and sealant compounds can burn easily, can give off harmful vapors, and are harmful to skin and clothing. To avoid injury or death, keep away from open fire and use in well-ventilated area. If adhesive, solvent, or sealant compound gets on skin or clothing, wash immediately with soap and water.

REMOVAL

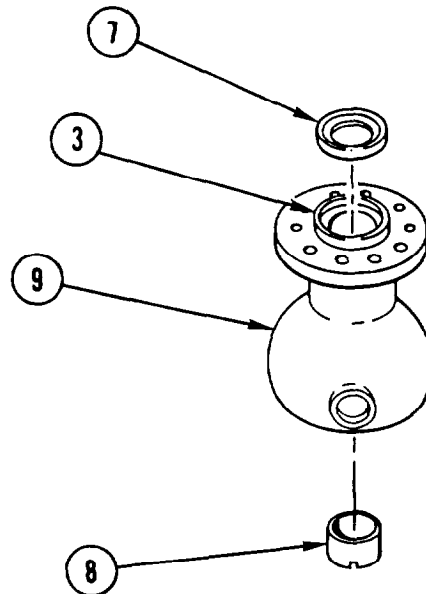
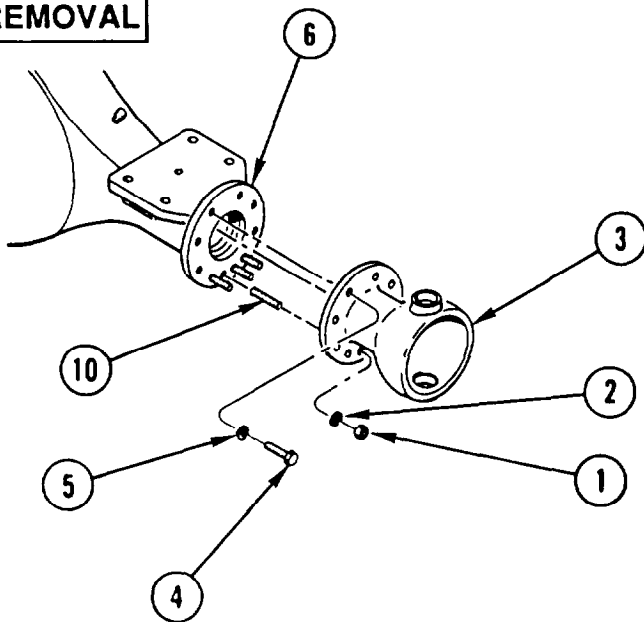

NOTE

Procedure is the same for both sides of axles. Left side of axle is shown.

1. REMOVE FOUR NUTS (1) AND FOUR WASHERS (2) FROM BOTTOM HOLES OF BALL AND BUSHING ASSEMBLY (3).

WARNING

Ball and bushing assembly is heavy and can injure personnel if dropped. Support ball and bushing assembly during removal.

2. REMOVE SIX BOLTS (4) AND SIX WASHERS (5) AND REMOVE BALL AND BUSHING ASSEMBLY (3) FROM AXLE HOUSING ASSEMBLY (6).
3. REMOVE OLD SEALANT FROM MOUNTING FACE OF AXLE HOUSING ASSEMBLY (6) AND BALL AND BUSHING ASSEMBLY (3).
4. PRY OIL SEAL (7) FROM BALL AND BUSHING ASSEMBLY (3). DISCARD OIL SEAL.
5. MEASURE OUTER DIAMETER OF FRONT AXLE SHAFT AND INNER DIAMETER OF AXLE BALL BUSHING (8). IF DIFFERENCE IS LESS THAN 0.008 IN. (0.203 mm) OR MORE THAN 0.020 IN. (0.508 mm), REMOVE BUSHING (8) FROM AXLE BALL (9).
6. IF DAMAGED, REMOVE FOUR STUDS (10).

CLEANING

Use general cleaning methods to clean all parts (page 2-30).

INSPECTION

Inspect all parts for wear or damage.

INSTALLATION

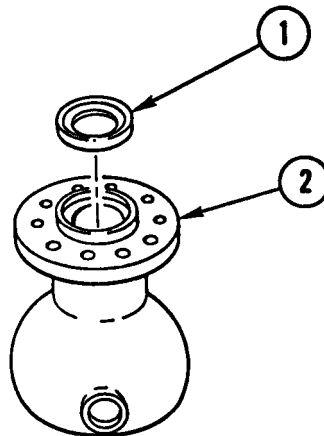

NOTE

Procedure is the same for both sides of axles. Left side of axle is shown.

1. INSTALL NEW OIL SEAL (1) IN AXLE BALL (2).

FRONT BALL, BUSHING, AND OIL SEAL REPLACEMENT (CONT)

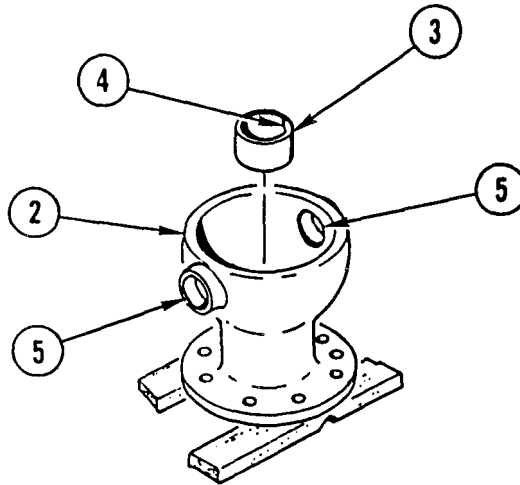

2. SUPPORT AXLE BALL (2) ON BLOCKS TO PROTECT SEAL END OF ASSEMBLY.
3. INSTALL AXLE BALL BUSHING (3) IN AXLE BALL (2) SO GREASE SLOTS (4) ARE ALIGNED WITH TRUNNION HOLES (5) AND OPEN ENDS OF GREASE SLOTS (4) FACE UP.

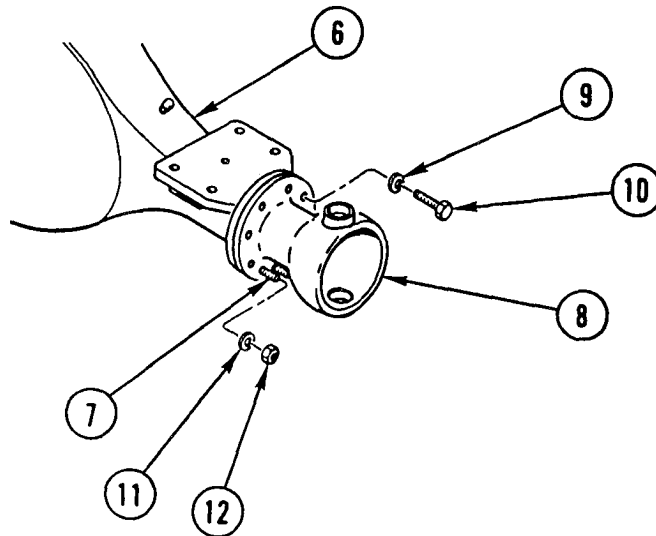

WARNING

Adhesives, solvents, and sealant compounds can burn easily, can give off harmful vapors, and are harmful to skin and clothing. To avoid injury or death, keep away from open fire and use in well-ventilated area. If adhesive, solvent, or sealant compound gets on skin or clothing, wash immediately with soap and water.

4. COAT MOUNTING FACE OF AXLE HOUSING ASSEMBLY (6) WITH SILICONE ADHESIVE-SEALANT.

5. IF REMOVED, INSTALL FOUR NEW STUDS (7) ON AXLE HOUSING ASSEMBLY (6).

WARNING

Ball and bushing assembly is heavy and can injure personnel if dropped.
Support ball and bushing assembly during installation.

6. INSTALL BALL AND BUSHING ASSEMBLY (8), SIX WASHERS (9), AND SIX BOLTS (10) ON AXLE HOUSING ASSEMBLY (6).
7. INSTALL FOUR WASHERS (11) AND FOUR NUTS (12) ON FOUR STUDS (7).

NOTE

Follow-on Maintenance:
Install front ball socket (page 5-15).

FRONT DIFFERENTIAL CARRIER REPLACEMENT

This task covers: a. Removal b. Cleaning c. Inspection d. Installation

INITIAL SETUP

Applicable Configuration:

All except M915A2

Tools and Special Equipment:

Shop Equipment, SC 4910-95-CL-A31
Tool Kit, SC 5180-90-CL-N05

Materials/Parts:

Washer, Lock (14) P/N 318BX
Adhesive-Sealant, Appendix B, Item 3
Silicone

Personnel Required: (2)

References:

TM 9-2320-363-20

Equipment Condition:

Reference	Condition Description
TM 9-2320-363-20	Driveline Removed
TM 9-2320-363-20	Axle Oil Drained from Differential
Page 5-7	Front Axle Shafts Removed
Page 5-52	Tie Rod Removed

General Safety Instructions:

WARNING

- Front differential carrier weighs 820 lb (372 kg). Attach suitable floor jack prior to removal or installation to prevent possible injury to personnel.
- Adhesives, solvents, and sealant compounds can burn easily, can give off harmful vapors, and are harmful to skin and clothing. To avoid injury or death, keep away from open fire and use in well-ventilated area. If adhesive, solvent, or sealant compound gets on skin or clothing, wash immediately with soap and water.
- Spilled gear oil is very slippery. Wipe up any spilled oil immediately. Failure to do so could result in serious injury to personnel.

REMOVAL

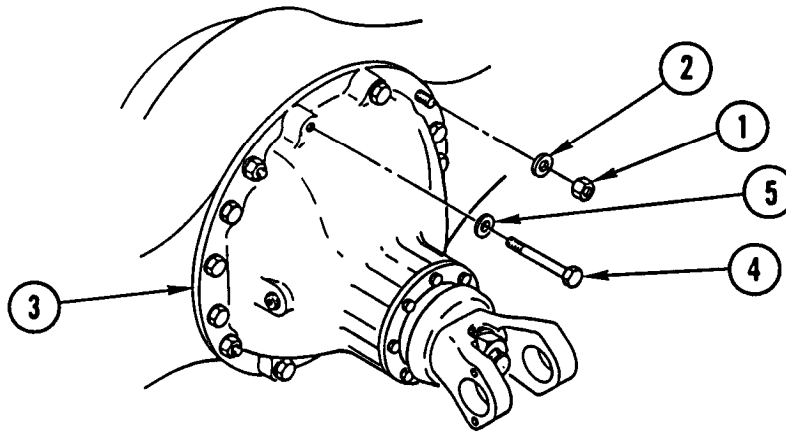

WARNING

Spilled gear oil is very slippery. Wipe up any spilled oil immediately. Failure to do so could result in serious injury to personnel.

1. REMOVE FOUR NUTS (1) AND FOUR LOCK WASHERS (2) FROM DIFFERENTIAL CARRIER (3). DISCARD LOCK WASHERS.
2. REMOVE EIGHT CAPSCREWS (4) AND EIGHT LOCK WASHERS (5). DISCARD LOCK WASHERS.

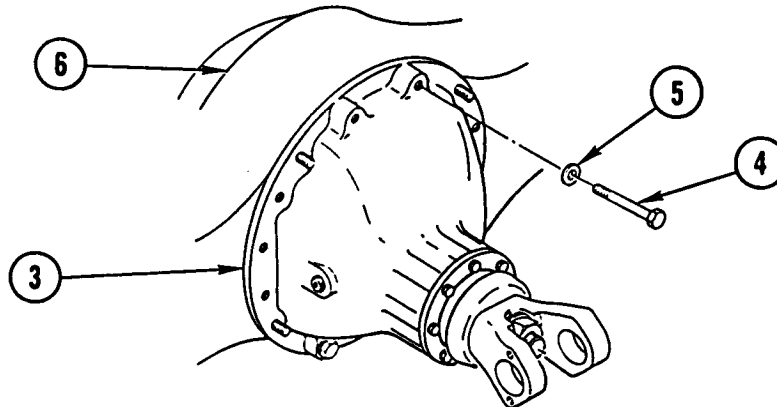

WARNING

Front differential carrier weighs 820 lb (372 kg). Attach suitable floor jack prior to removal to prevent possible injury to personnel.

3. ATTACH SUITABLE FLOOR JACK TO DIFFERENTIAL CARRIER (3).

CAUTION

To avoid damage, do not strike to loosen differential carrier. Tap around edge of flange.

4. REMOVE TWO REMAINING CAPSCREWS (4), TWO LOCK WASHERS (5), AND DIFFERENTIAL CARRIER (3) FROM AXLE HOUSING (6). DISCARD LOCK WASHERS.

FRONT DIFFERENTIAL CARRIER REPLACEMENT (CONT)

CLEANING

Use general cleaning methods to clean all parts (page 2-30).

INSPECTION

Inspect all parts for wear or damage.

INSTALLATION

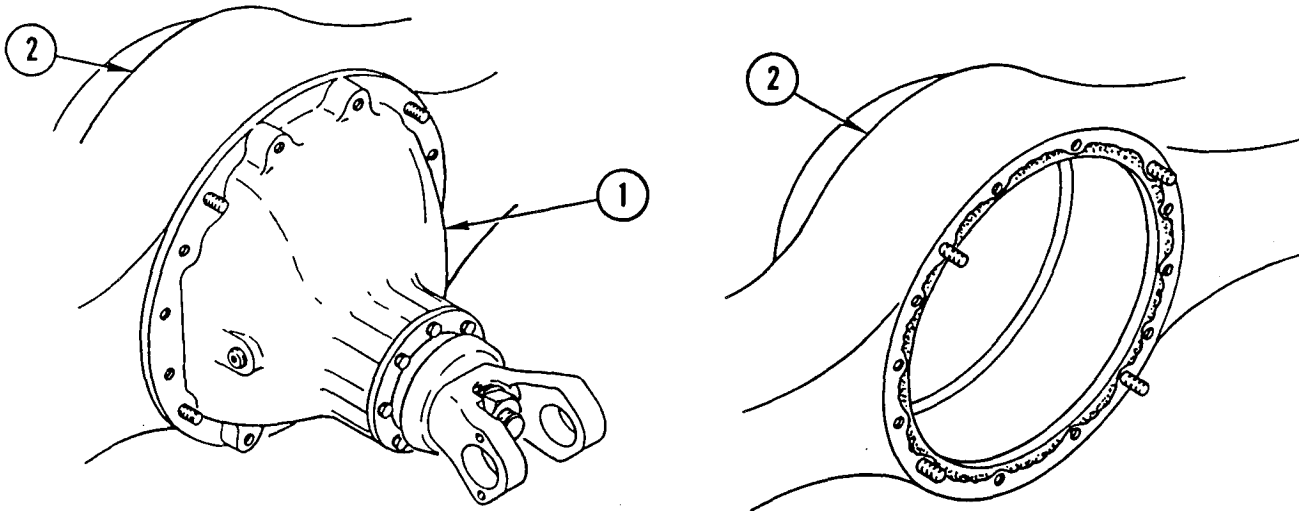

WARNING

- Front differential carrier weighs 820 lb (372 kg). Attach suitable floor jack prior to installation to prevent possible injury to personnel.
- Spilled gear oil is very slippery. Wipe up any spilled oil immediately. Failure to do so could result in serious injury to personnel.

1. ATTACH SUITABLE FLOOR JACK TO DIFFERENTIAL CARRIER (1).

WARNING

Adhesives, solvents, and sealant compounds can burn easily, can give off harmful vapors, and are harmful to skin and clothing. To avoid injury or death, keep away from open fire and use in well-ventilated area. If adhesive, solvent, or sealant compound gets on skin or clothing, wash immediately with soap and water,

2. APPLY SILICONE ADHESIVE-SEALANT TO AXLE HOUSING (2) IN PATTERN SHOWN.
3. INSTALL DIFFERENTIAL CARRIER (1) IN AXLE HOUSING (2).

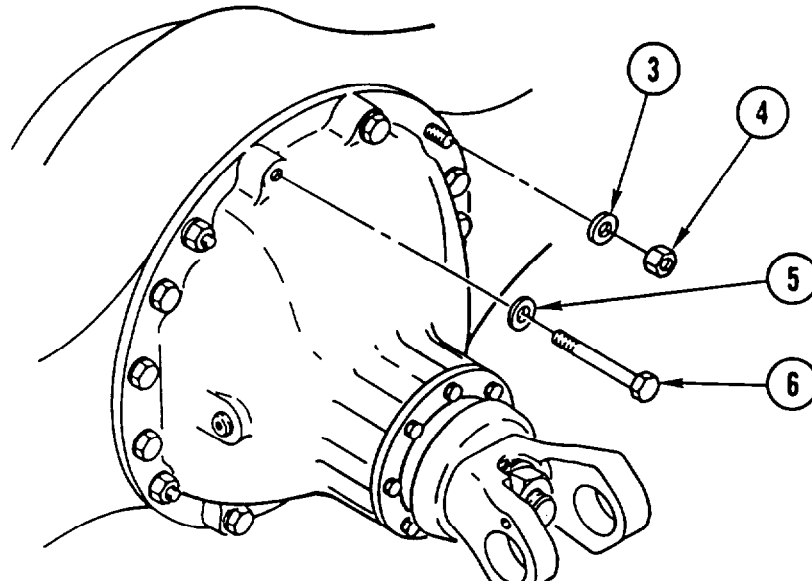

4. INSTALL FOUR NEW LOCK WASHERS (3) AND FOUR NUTS (4). TIGHTEN NUTS TO 130 LB-FT (176.25 N.m).
5. INSTALL 10 NEW LOCK WASHERS (5) AND 10 CAPSCREWS (6). TIGHTEN CAPSCREWS TO 130 LB-FT (176.25 N.m).

NOTE

Follow-on Maintenance:

- Install front axle shafts (page 5-7).
- Install driveline (TM 9-2320-363-20).
- Fill differential with axle oil (TM 9-2320-363-20).
- Install tie rod (page 5-52).

FRONT YOKE AND OIL SEAL REPLACEMENT

This task covers: a. Removal b. Cleaning c. Inspection d. Installation

INITIAL SETUP

Applicable Configuration:

All except M915A2

Tools and Special Equipment:

Shop Equipment, SC 4910-95-CL-A31
Tool Kit, SC 5180-90-CL-N05
Yoke Holder Bar, J3453

Materials/Parts:

Seal, Oil	P/N A1205P1914
Nut, Lock	P/N 1227-J-946-S
Cil, Lubricating	Appendix B, Item 37

Personnel Required: (2)

References:

TM 9-2320-363-20
TM 9-2320-363-10

Equipment Condition:

Reference	Condition	Description
TM 9-2320-363-20	Driveline	Removed
TM 9-2320-363-10	Differential	Locked

REMOVAL

1. USING YOKE HOLDER BAR, REMOVE LOCK NUT (1), WASHER (2), AND YOKE (3) FROM DIFFERENTIAL SHAFT (4). DISCARD LOCK NUT.
2. REMOVE AND DISCARD OIL SEAL (5).

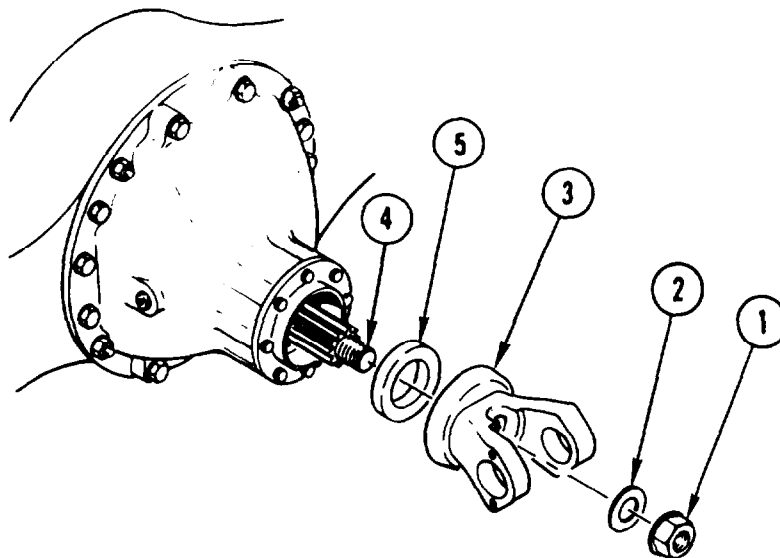

CLEANING

Use general cleaning methods to clean all parts (page 2-30).

INSPECTION

1. INSPECT ALL PARTS FOR WEAR OR DAMAGE.
2. APPLY LIGHT FILM OF OIL ON YOKE.

INSTALLATION

1. APPLY LUBRICATING OIL TO NEW OIL SEAL (5) AND INSTALL OIL SEAL (5).

NOTE

To tighten yoke nut, use torque multiplier and 250 lb-ft (339 N.m) capacity ratchet-end torque wrench.

2. USING YOKE HOLDER BAR, INSTALL YOKE (3), WASHER (2), AND NEW LOCK NUT (1) AND DIFFERENTIAL SHAFT (4). TIGHTEN NUT TO 450-600 LB-FT (610-814 N.m).

NOTE

Follow-on Maintenance:

Install driveline (TM 9-2320-363-20).

Fill axle with oil (TM 9-2320-363-20).

FRONT AXLE ASSEMBLY REPLACEMENT

This task covers: a. Removal b. Cleaning c. Inspection d. Installation

INITIAL SETUP

Applicable Configuration:

M915A2

Tools and Special Equipment:

Shop Equipment, SC 4910-95-CL-A31
Tool Kit, SC 5180-90-CL-N05

Materials/Parts:

Pin, Cotter

Pin, Cotter (2)

Alumilastic

Appendix B, Item 6

Personnel Required: (2)

References:

TM 9-2320-363-20

Equipment Condition:

Reference

Condition Description

TM 9-2320-363-20

Front Brake Spider and
Brake Chamber Bracket
Removed

General Safety Instructions:

WARNING

Front axle weighs 1,060 lb (481 kg). Support front axle with suitable floor jack during removal or installation to prevent possible injury to personnel.

REMOVAL

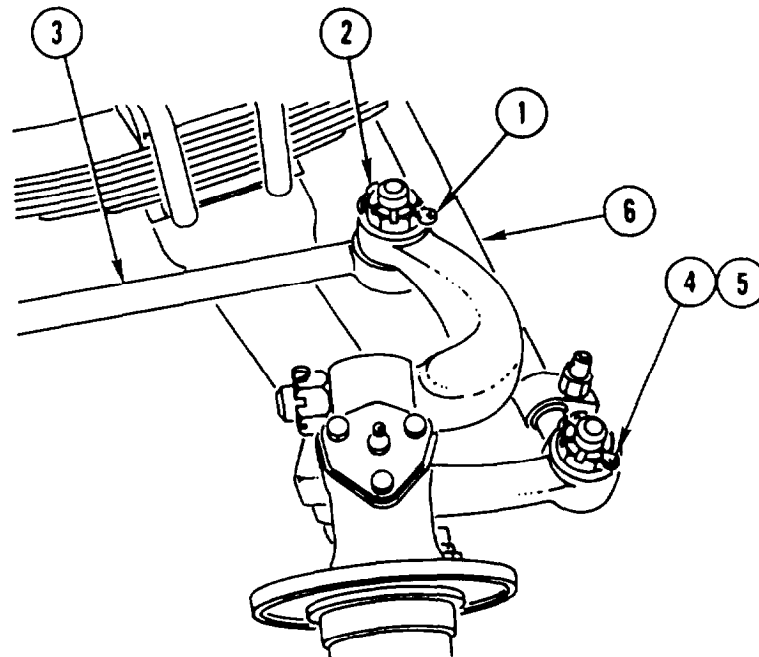

NOTE

Procedure is the same for both sides except where noted.

1. ON LEFT SIDE, REMOVE COTTER PIN (1) AND CASTELLATED NUT (2) AND SET DRAG LINK (3) ASIDE. DISCARD COTTER PIN.
2. REMOVE TWO COTTER PINS (4), TWO CASTELLATED NUTS (5), AND TIE ROD (6), DISCARD COTTER PINS.

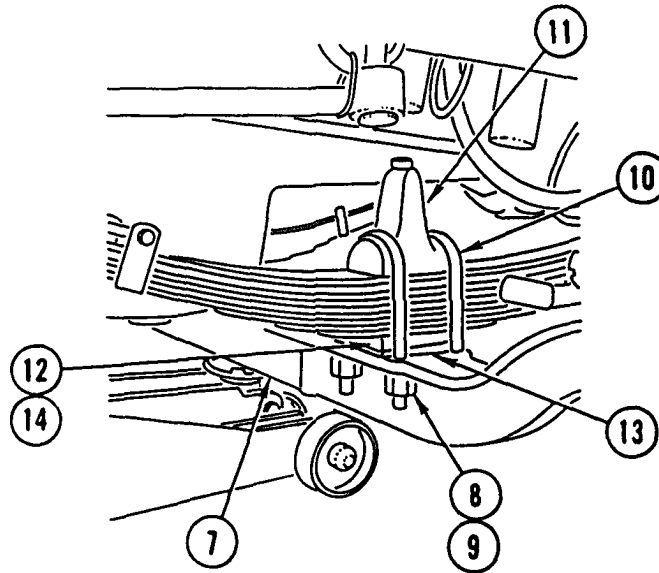
**WARNING**

Front axle weighs 1,060 lb (481 kg). Support front axle with suitable floor jack during removal to prevent possible injury to personnel.

NOTE

Make sure front of vehicle is blocked up enough to allow removal of axle.

3. POSITION SUITABLE FLOOR JACK UNDER CENTER OF AXLE (7) AND SECURE AXLE TO FLOOR JACK.

NOTE

Note position of axle stops during removal to aid in installation.

4. REMOVE EIGHT NUTS (8), EIGHT WASHERS (9), FOUR U-BOLTS (10), AND TWO AXLE STOPS (11).
5. LOWER AXLE (7) AND REMOVE FROM VEHICLE.
6. REMOVE SPACER (12) AND SHIM (13).
7. REMOVE PIN (14) FROM SPACER (12).
8. USING LIFTING DEVICE, REMOVE AXLE (7) FROM FLOOR JACK.

FRONT AXLE ASSEMBLY REPLACEMENT (CONT)

CLEANING

Use general cleaning methods to clean all parts (page 2-30).

INSPECTION

Inspect all parts for wear or damage.

INSTALLATION

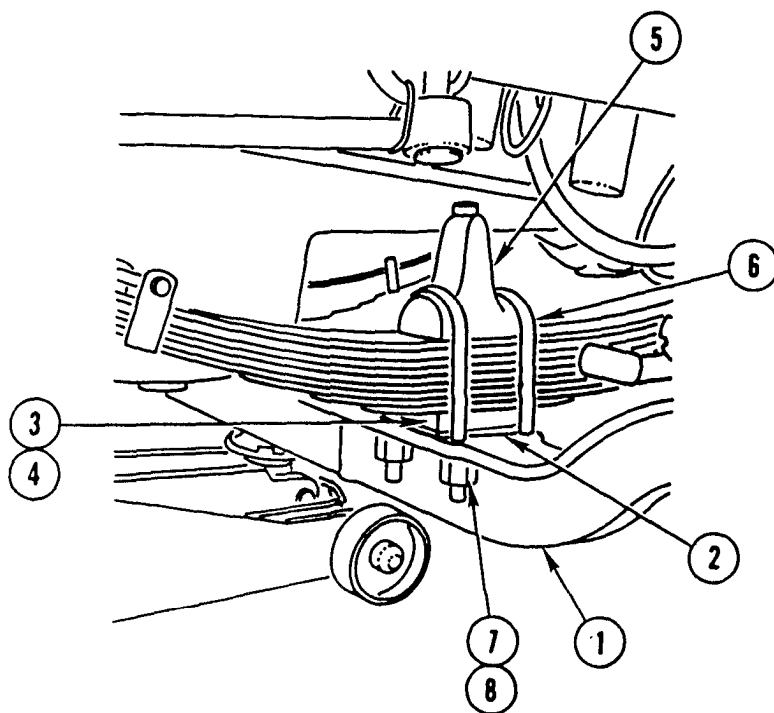

WARNING

Front axle weighs 1,060 lb (481 kg). Support front axle with suitable floor jack during installation to prevent possible injury to personnel.

NOTE

Procedure is the same for both sides except where noted.

1. WITH AXLE (1) INSTALLED AND SECURED ON SUITABLE FLOOR JACK, POSITION AXLE (1) UNDER VEHICLE.
2. COAT BOTTOM OF SHIM (2) WITH ALUMILASTIC AND INSTALL SHIM (2) ON AXLE (1) WITH WIDE END OF SHIM (2) TOWARD REAR OF VEHICLE.

3. INSTALL PIN (3) IN SPACER (4).
4. COAT TOP OF SPACER (4) WITH ALUMILASTIC AND INSTALL SPACER (4) ON TOP OF SHIM (2).
5. INSTALL AXLE (1).
6. COAT BOTTOM AND U-BOLT SADDLES OF TWO AXLE STOPS (5) With ALUMILASTIC.
7. INSTALL TWO AXLE STOPS (5), FOUR U-BOLTS (6), EIGHT WASHERS (7), AND EIGHT NUTS (8) ON AXLE (1). TIGHTEN NUTS TO 380-460 LB-FT (515-624 N.m).

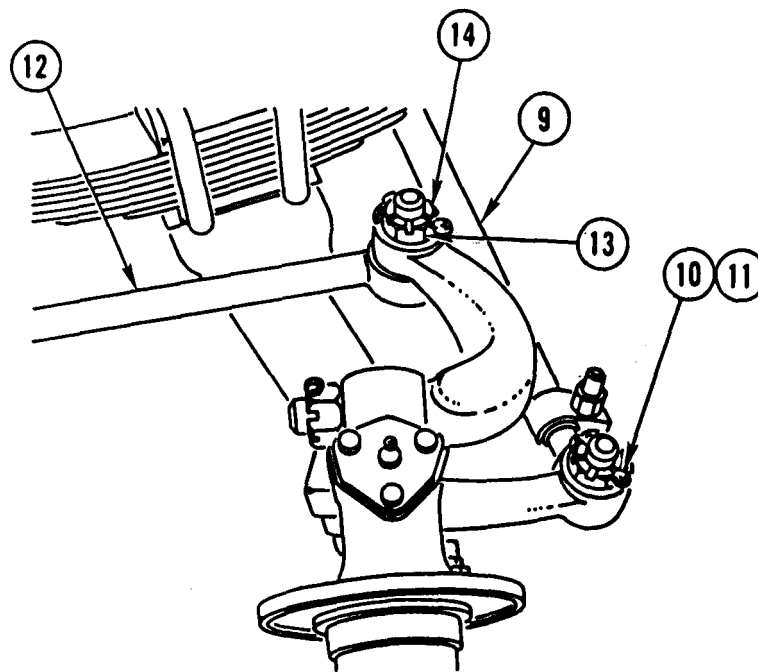

8. REMOVE FLOOR JACK FROM UNDER VEHICLE.
9. INSTALL TIE ROD (9) AND TWO CASTELLATED NUTS (10). TIGHTEN NUTS TO 165-180 LB-FT (224-244 N.m).
10. INSTALL TWO NEW COTTER PINS (11) THRU TWO CASTELLATED NUTS (10).
11. ON LEFT SIDE, INSTALL DRAG LINK (12) AND CASTELLATED NUT (13), TIGHTEN NUT TO 165-180 LB-FT (224-244 N.m).
12. INSTALL NEW COTTER PIN (14) THRU CASTELLATED NUT (13).

NOTE

Follow-on Maintenance:
 Install front brake spider and brake chamber bracket (TM 9-2320-363-20).
 Check and adjust front axle caster alignment (page 5-60).

FRONT STEERING KNUCKLE REPLACEMENT AND REPAIR

This task covers: a. Removal b. Cleaning c. Inspection d. Repair e. Installation

INITIAL SETUP

Applicable Configuration:

M915A2

Tools and Special Equipment:

Shop Equipment, SC 4910-95-CL-A31
 Tool Kit, SC 5180-90-CL-N05
 Bushing Driver, PT-4365-1

Materials/Parts:

Seal Assembly (2)	P/N A-1205-X-1428
Gasket (2)	P/N 3208-M-1027
Shim	P/N 2203-L-3002
Shim	P/N 2203-K-3001
Seal Assembly	P/N A-1205-B-1432
Bushing (2)	P/N 1225-W-985
Washer, Lock (6)	P/N 1229-E-1669

References:

LO 9-2320-363-12

Equipment Condition:

Reference	Condition Description
Page 5-52	Tie Rod Removed
Page 5-58	Front Cross Tube Arm Removed
Page 5-56	Front Steering Arm Removed

General Safety Instructions:

WARNING
 Shims are delicate and sharp. Use extreme caution when alining shims to prevent cutting fingers or bending inside diameter of shims. Damage to shims will require complete disassembly and replacement of damaged parts.

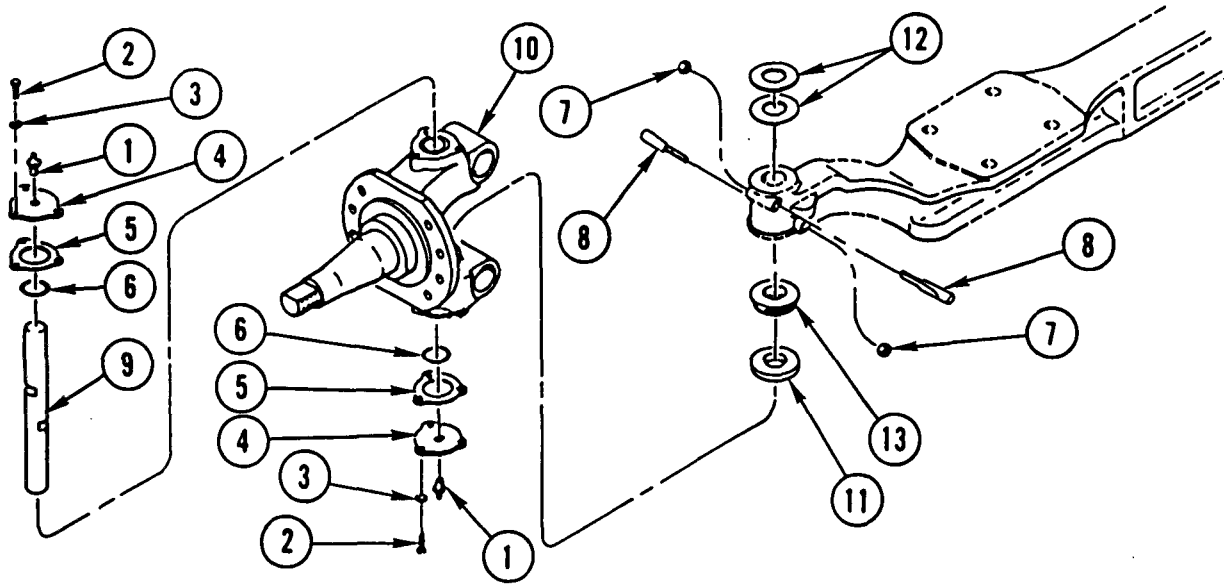
REMOVAL**NOTE**

Procedure is the same for both steering knuckles.

1. IF DAMAGED, REMOVE TWO LUBRICATION FITTINGS (1).
2. REMOVE SIX CAPSCREWS (2), SIX LOCK WASHERS (3), TWO CAPS (4), TWO GASKETS (5), AND TWO SEAL ASSEMBLIES (6). DISCARD GASKETS, SEAL ASSEMBLIES, AND LOCK WASHERS.
3. REMOVE TWO NUTS (7).

NOTE

Tag draw keys prior to removal to aid in installation.

4. REMOVE TWO DRAW KEYS (8).

CAUTION

Be **careful** when removing pin. If pin is dropped, damage may occur.

5. REMOVE PIN (9).
6. REMOVE STEERING KNUCKLE (10), THRUST BEARING (11), SHIM(S) (12), AND SEAL ASSEMBLY (13). DISCARD SEAL ASSEMBLY AND SHIM(S).

FRONT STEERING KNUCKLE REPLACEMENT AND REPAIR (CONT)

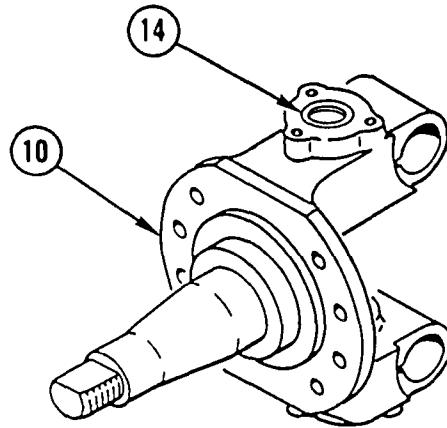

7. REMOVE TWO BUSHINGS (14) FROM STEERING KNUCKLE (10). DISCARD BUSHINGS.

CLEANING

Use general cleaning methods to clean all parts (page 2-30).

INSPECTION

1. INSPECT ALL PARTS FOR WEAR OR DAMAGE.
2. INSPECT BORE OF STEERING KNUCKLE. IF DIAMETER EXCEEDS 1.922 IN. (48.818 mm), REPLACE WITH NEW PART.
3. INSPECT BORE OF AXLE BEAM. IF DIAMETER EXCEEDS 1.798 IN. (45.669 mm), REPLACE WITH NEW PART.

REPAIR

Repair of steering knuckle is the replacement of all parts found to be damaged or unserviceable.

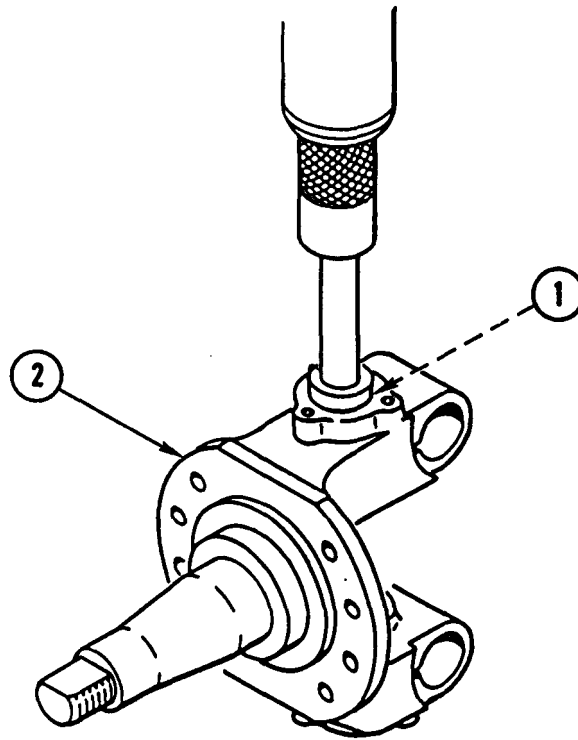
INSTALLATION**NOTE**

Procedure is the same for both steering knuckles.

1. USING BUSHING DRIVER, INSTALL TWO NEW BUSHINGS (1) AS FOLLOWS:
 - PRESS BUSHING (1) INTO STEERING KNUCKLE (2) 1/8 IN. AND RELIEVE PRESSURE,
 - PRESS BUSHING (1) INTO STEERING KNUCKLE (2) ANOTHER 1/2 IN. AND RELIEVE PRESSURE.
 - PRESS BUSHING (1) INTO STEERING KNUCKLE (2) UNTIL BUSHING IS 5/16 IN. BELOW SEAL COUNTERBORE.
- REPEAT FOR REMAINING BUSHING (1).

FRONT STEERING KNUCKLE REPLACEMENT AND REPAIR (CONT)

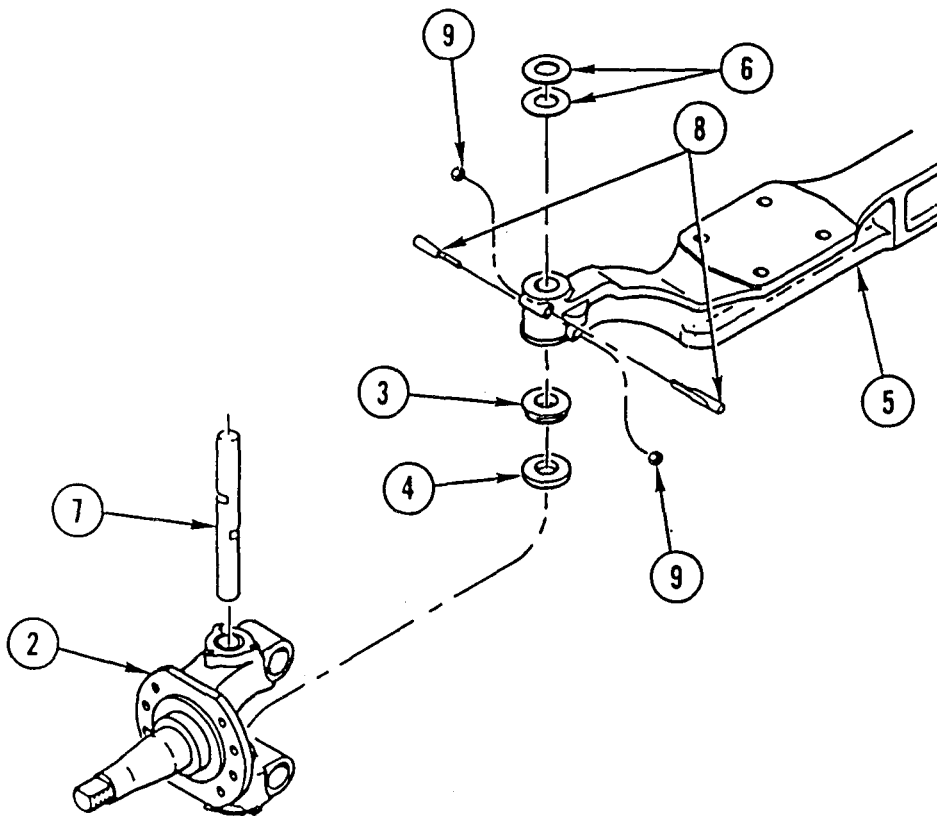

2. INSTALL NEW SEAL ASSEMBLY (3) ON CHAMFERED SIDE OF THRUST BEARING (4).
3. INSTALL STEERING KNUCKLE (2).
4. INSTALL THRUST BEARING (4) AND SEAL ASSEMBLY (3).
5. USING SUITABLE JACK, RAISE STEERING KNUCKLE (2) UNTIL SEAL ASSEMBLY (3) IS FLUSH WITH BOTTOM SIDE OF AXLE (5).
6. USING FEELER GAGE, MEASURE DISTANCE BETWEEN TOP SIDE OF AXLE (5) AND STEERING KNUCKLE (2).

WARNING

Shims are delicate and sharp. Use extreme caution when aligning shims to prevent cutting fingers or bending inside diameter of shims. Damage to shims will require complete disassembly and replacement of damaged parts.

7. INSTALL NEW SHIM(S) (6) OF THICKNESS EQUAL TO MEASUREMENT FROM STEP 6.

CAUTION

Make sure shim(s) is not blocking passage for pin installation to prevent damage to equipment.

NOTE

- Make sure draw key slots align with draw key holes.
- If pin will not pass completely thru steering knuckle, but passed thru shim(s), lower jack to align thrust bearing and seal assembly to allow passage of pin.

8. INSTALL PIN (7) IN STEERING KNUCKLE (2).
9. INSTALL TWO DRAW KEYS (8) AND TWO NUTS (9). TIGHTEN NUTS TO 30-40-LB-FT (41-54 N.m).

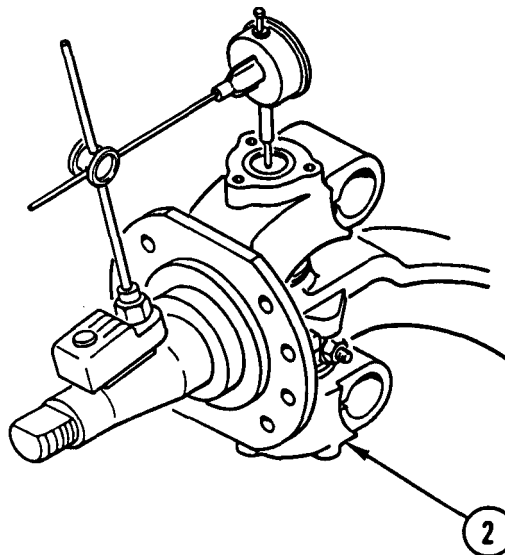

10. POSITION STEERING KNUCKLE (2) IN STRAIGHT-AHEAD POSITION AND INSTALL DIAL INDICATOR ON STEERING KNUCKLE (2) AS SHOWN.

FRONT STEERING KNUCKLE REPLACEMENT AND REPAIR (CONT)

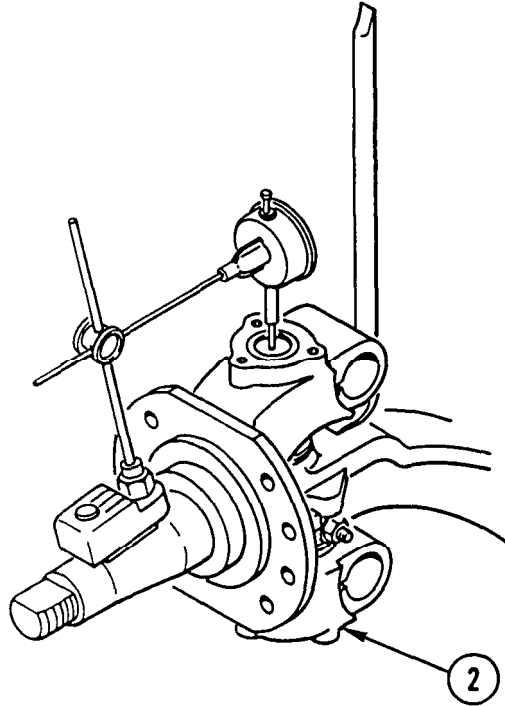

11. PRY UP ON STEERING KNUCKLE (2) WHILE OBSERVING DIAL INDICATOR. VERTICAL END PLAY MUST BE 0.001-0.025 IN. (0.02-0.64 mm). IF VERTICAL END PLAY IS LESS THAN 0.001 IN. (0.02 mm), REMOVE SHIM(S) TO ACHIEVE VERTICAL END PLAY. IF VERTICAL END PLAY IS MORE THAN 0.025 IN. (0.64 mm), ADD SHIM(S) TO REDUCE VERTICAL END PLAY.
12. IF SHIM(S) IS TO BE ADDED OR REMOVED, PERFORM REMOVAL STEPS 3 THRU 7 AND INSTALLATION STEPS 1 THRU 11 UNTIL CORRECT VERTICAL END PLAY IS ACHIEVED.

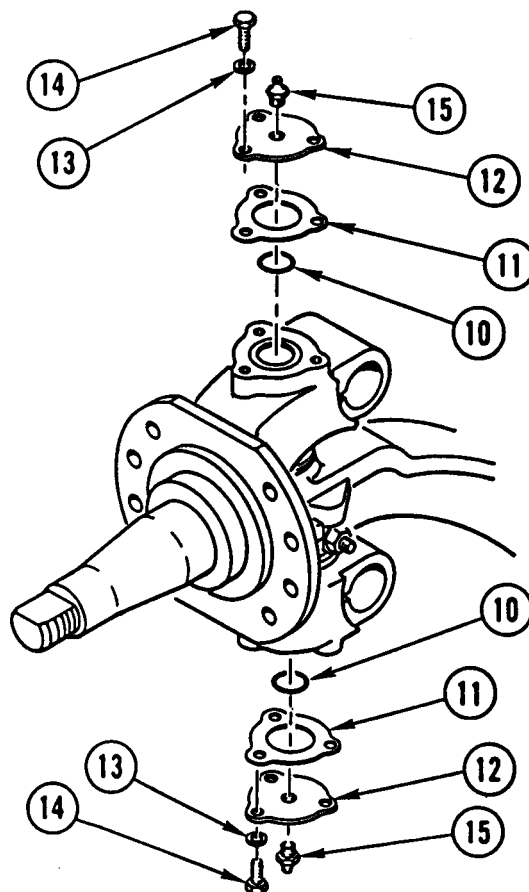

13. INSTALL TWO NEW SEAL ASSEMBLIES (10), TWO NEW GASKETS (11), TWO CAPS (12), SIX NEW LOCK WASHERS (13), AND SIX CAPSCREWS (14). TIGHTEN CAPSCREWS TO 20-30 LB-FT (27-41 N.m).

14. IF REMOVED, INSTALL TWO NEW LUBRICATION FITTINGS (15).

NOTE

Follow-on Maintenance:

Install front cross tube arm (page 5-58).

Install front steering arm (page 5-56).

Install tie rod (page 5-52).

Lubricate steering knuckle (LO 9-2320-363-12).

TIE ROD REPLACEMENT AND REPAIR

This task covers: a. Removal b. Disassembly c. Cleaning d. Inspection e. Repair f. Assembly g. Installation

INITIAL SETUP

Tools and Special Equipment:

Shop Equipment, SC 4910-95-CL-A31
Tool Kit, SC 5180-90-CL-N05

References:

TM 9-2320-363-20

Materials/Parts:

Pin, Cotter

Fitting, Lubrication

REMOVAL

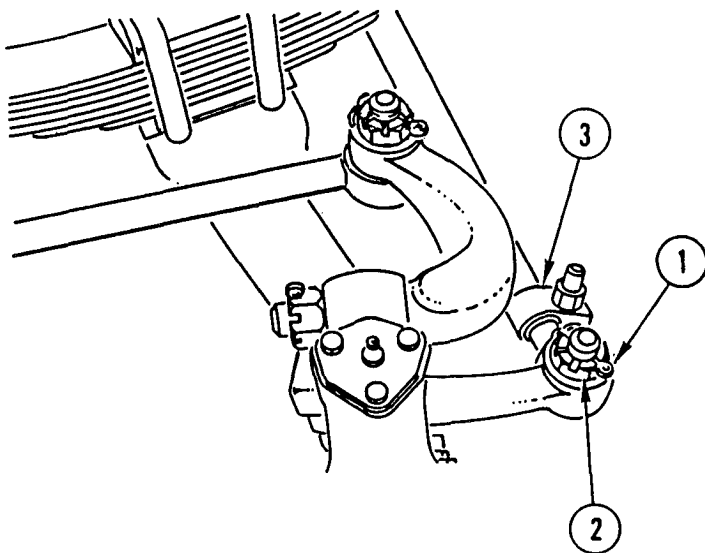

NOTE

Procedure is the same for both tie rods.

REMOVE COTTER PIN (1), CASTELLATED NUT (2), AND TIE ROD (3). DISCARD COTTER PIN.

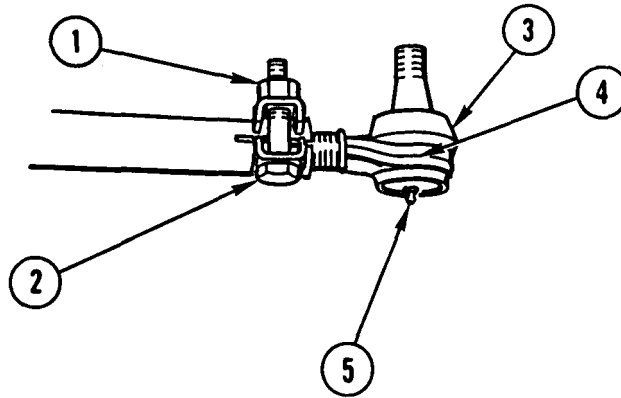
DISASSEMBLY**NOTE**

Procedure is the same for both tie rod ends.

1. REMOVE LOCK NUT (1) AND CAPSCREW (2).
2. REMOVE DUST COVER (3).

NOTE

- Note number of turns necessary to remove tie rod end.
- Left tie rod end has left-hand threads. Right tie rod end has right-hand threads.

3. REMOVE TIE ROD END (4).
4. IF DAMAGED, REMOVE LUBRICATION FITTING (5).

CLEANING

Use general cleaning methods to clean all parts (page 2-30).

INSPECTION

Inspect all parts for wear or damage.

REPAIR

Repair of tie rod is the replacement of any worn or damaged parts.

TIE ROD REPLACEMENT AND REPAIR (CONT)

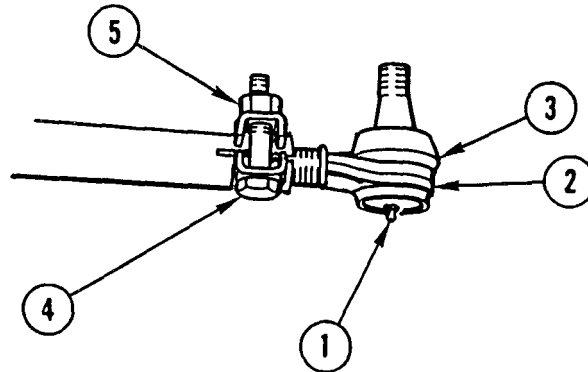

NOTE

Procedure is the same for both tie rod ends.

1. IF REMOVED, INSTALL NEW LUBRICATION FITTING (1).

NOTE

Left tie rod end has left-hand threads. Right tie rod end has right-hand threads.

2. INSTALL TIE ROD END (2) NUMBER OF TURNS NOTED DURING DISASSEMBLY.
3. INSTALL DUST COVER (3).
4. INSTALL CAPSCREW (4) AND LOCK NUT (5). DO NOT TIGHTEN LOCK NUT.

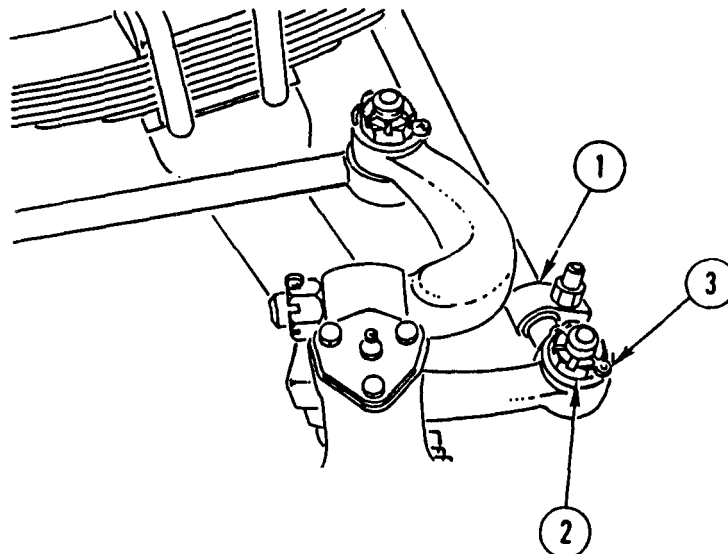

NOTE

Procedure is the same for both tie rods.

INSTALL TIE ROD (1), CASTELLATED NUT (2), AND NEW COTTER PIN (3). TIGHTEN CASTELLATED NUT TO 165-180 LB-FT (224-244 N.m).

NOTE

Follow-on Maintenance:
Check front axle toe-in alignment (TM 9-2320-363-20).

FRONT STEERING ARM REPLACEMENT

This task covers: a. Removal b. Cleaning c. Inspection d. Installation

INITIAL SETUP

Applicable Configuration:

M915A2

Tools and Special Equipment:

Shop Equipment, SC 4910-95-CL-A31
Tool Kit, SC 5180-90-CL-N05

Materials/Parts:

Pin, Cotter

References:

TM 9-2320-363-20

Equipment Condition:

Reference

TM 9-2320-363-20

TM 9-2320-363-20

Condition Description

Drag Link Removed

Front Brake Spider and
Brake Chamber Bracket
Removed

REMOVAL

REMOVE COTTER PIN (1), CASTELLATED NUT (2), STEERING ARM (3), AND WOODRUFF KEY (4). DISCARD COTTER PIN.

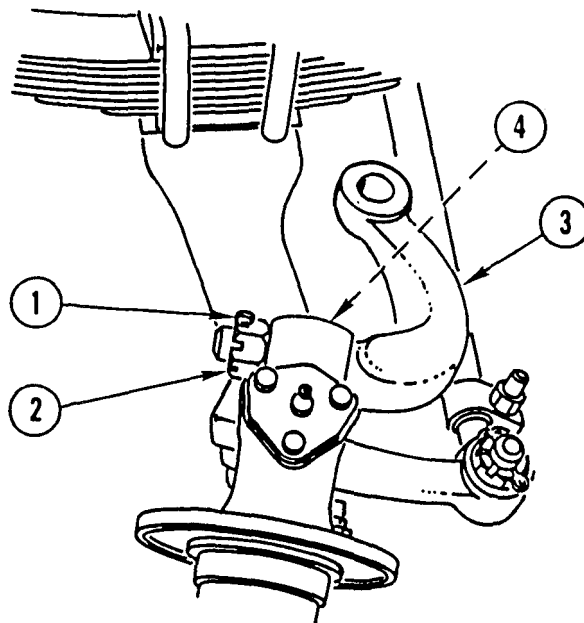

CLEANING

Use general cleaning methods to clean all parts (page 2-30).

INSPECTION

Inspect all parts for wear or damage.

INSTALLATION

1. INSTALL WOODRUFF KEY (4), STEERING ARM (3), AND CASTELLATED NUT (2). TIGHTEN CASTELLATED NUT TO 775-1,050 LB-FT (1051-1424 N.m).

CAUTION

Castellated nut may be tightened to 1,450 lb-ft (1966 N.m) for purpose of installing cotter pin. Overtightening may damage steering arm.

2. INSTALL NEW COTTER PIN (1).

NOTE

Follow-on Maintenance:

Install drag link (TM 9-2320-363-20).

Install front brake spider and brake chamber bracket (TM 9-2320-363-20).

FRONT CROSS TUBE ARM REPLACEMENT

This task covers: a. Removal b. Cleaning c. Inspection d. Installation

INITIAL SETUP

Tools and Special Equipment:

Shop Equipment, SC 4910-95-CL-A31
Tool Kit, SC 5180-90-CL-N05

Materials/Parts:

Pin, Cotter

Equipment Condition:

Reference

Page 5-52

Condition Description

Tie Rod Removed

REMOVAL

NOTE

Procedure is the same for both cross tube arms.

REMOVE COTTER PIN (1), CASTELLATED NUT (2), CROSS TUBE ARM (3), AND WOODRUFF KEY (4). DISCARD COTTER PIN.

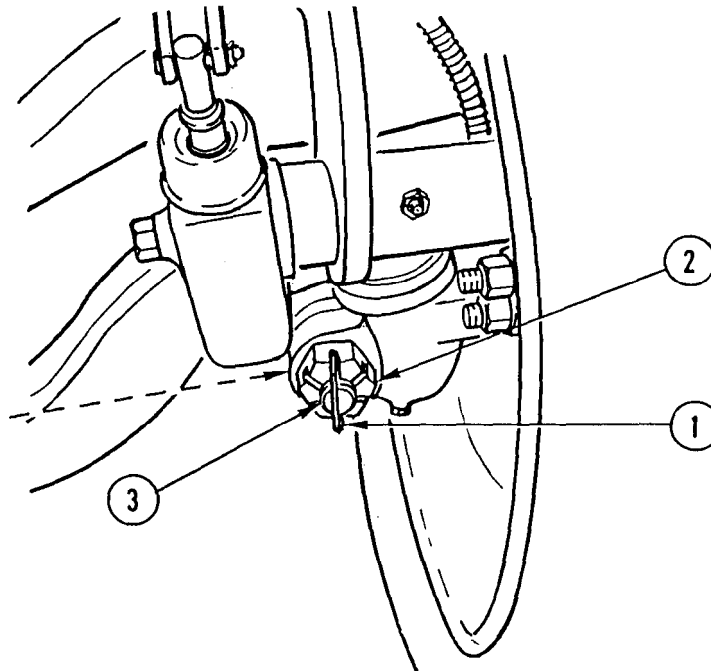

CLEANING

Use general cleaning methods to clean all parts (page 2-30).

INSPECTION

Inspect all parts for wear or damage.

INSTALLATION**NOTE**

Procedure is the same for both cross tube arms.

1. INSTALL WOODRUFF KEY (4), CROSS TUBE ARM (3), AND CASTELLATED NUT (2). TIGHTEN CASTELLATED NUT TO 550-740 LB-FT (746-1003 N.m).

CAUTION

Castellated nut may be tightened to 1,025 lb-ft (1390 N.m) for purpose of installing cotter pin. Overtightening may damage steering arm.

2. INSTALL NEW COTTER PIN (1).

NOTE

Follow-on Maintenance:

Install tie rod (page 5-52).

FRONT AXLE CASTER ADJUSTMENT

This task covers: Adjustment

INITIAL SETUP

Applicable Configuration:

M915A2

Tools and Special Equipment:

Shop Equipment, SC 4910-95-CL-A31
Tool Kit, SC 5180-90-CL-N05

Materials/Parts:

Compound,
Antiseize

Appendix B, Item 11

General Safety Instructions:

WARNING

- Before removing shim(s), make sure vehicle is properly supported to prevent possible injury to personnel.
- If more than one shim is to be added, shims must be welded together prior to installation. Failure to do so may cause shim slippage resulting in equipment damage and/or injury to personnel.

ADJUSTMENT

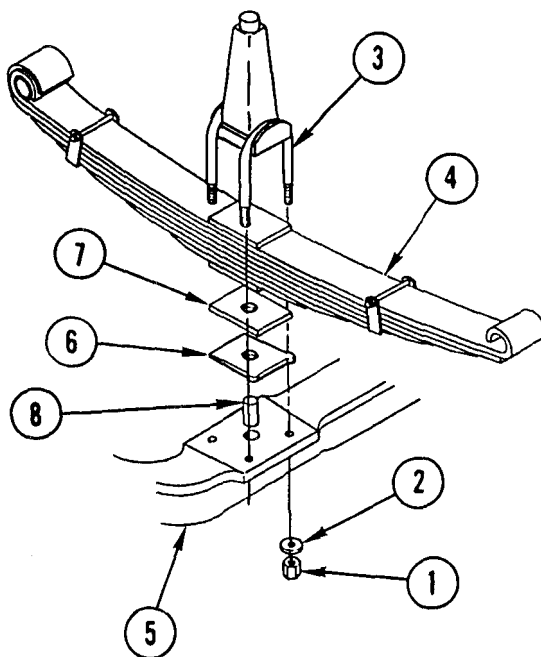

NOTE

Manufacturer's operating instructions for alinement equipment must be followed to perform step 1.

1. MEASURE CASTER ANGLE. ANGLE MUSTBE $+3-1/2^{\circ}$ TO $+6-1/2^{\circ}$.

NOTE

Perform steps 2 thru 9 if caster angle is incorrect.

2. REMOVE FOUR NUTS (1) AND FOUR WASHERS (2) FROM TWO U-BOLTS (3).

WARNING

Before removing shim(s), make sure vehicle is properly supported to prevent possible injury to personnel.

3. RAISE SPRING (4) HIGH ENOUGH FROM AXLE (5) TO ALLOW REMOVAL OF SHIM(S) (6).
4. REMOVE SPACER (7), SHIM(S) (6), AND DOWEL (8).
5. INSTALL DOWEL (8) IN AXLE (5).

WARNING

If more than one shim is to be added, shims must be welded together prior to installation. Failure to do so may cause shim slippage resulting in equipment damage and/or injury to personnel.

NOTE

Install shims with tapered end toward front of vehicle.

6. INSTALL NEW SHIM(S) (6) TO OBTAIN $+3-1/2^{\circ}$ TO $+6-1/2^{\circ}$ OF CASTER ANGLE.

NOTE

Make sure dowel protrudes thru shim(s) enough to hold spacer in place. if dowel will not protrude into spacer, replace dowel.

7. INSTALL SPACER (7).
8. LOWER SPRING (4) ONTO AXLE (5).
9. COAT THREADS OF TWO U-BOLTS (3) WITH ANTISEIZE COMPOUND.
10. INSTALL FOUR WASHERS (2) AND FOUR NUTS (1) ON TWO U-BOLTS (3). TIGHTEN NUTS TO 380-460 LB-FT (515-624 N.m).

CHAPTER 6
REAR AXLE MAINTENANCE

OVERVIEW

This chapter illustrates and describes procedures for maintenance of the rear axle and related parts. A list of tasks contained in this chapter is shown below.

	Page
Forward-Rear Axle Differential Carrier Replacement	6-2
Output Shaft Replacement and Repair	6-7
Rear-Rear Axle Differential Carrier Replacement	6-12
Rear Axle Replacement (M915A2)	6-16
Rear Axle Replacement (All Except M915A2))	6-22
Rear Yoke and Oil Seal Replacement (M915A2)	6-28
Rear Yoke and Oil Seal Replacement (All Except M915A2))	6-30

FORWARD-REAR AXLE DIFFERENTIAL CARRIER REPLACEMENT

This task covers: a. Removal b. Cleaning c. Inspection d. Installation

INITIAL SETUP

General Safety Instructions:

Tools and Special Equipment:

Shop Equipment, SC 4910-95-CL-A31
Tool Kit, SC 5180-90-CL-N05

Materials/Parts:

Compound, Sealing Appendix B, Item 16

Personnel Required: (2)

References:

TM 9-2320-363-20

Equipment Condition:

Reference	Condition Description
TM 9-2320-363-20	Air System Drained
TM 9-2320-363-20	Axle Shafts Removed
TM 9-2320-363-20	Grate Removed (M916A1 and M916A2)
TM 9-2320-363-20	Drivelines Disconnected
TM 9-2320-363-20	Axle Oil Filter Removed
Page 6-7	Output Shaft Removed
TM 9-2320-363-20	Axle Oil Drained

WARNING

- Forward-rear axle differential carrier weighs 1,160 lb (526 kg). Attach suitable floor jack prior to removal or installation to prevent possible injury to personnel.
- Adhesives, solvents, and sealing compounds can burn easily, can give off harmful vapors, and are harmful to skin and clothing. To avoid injury or death, keep away from open fire and use in well-ventilated area. If adhesive, solvent, or sealing compound gets on skin or clothing, wash immediately with soap and water.

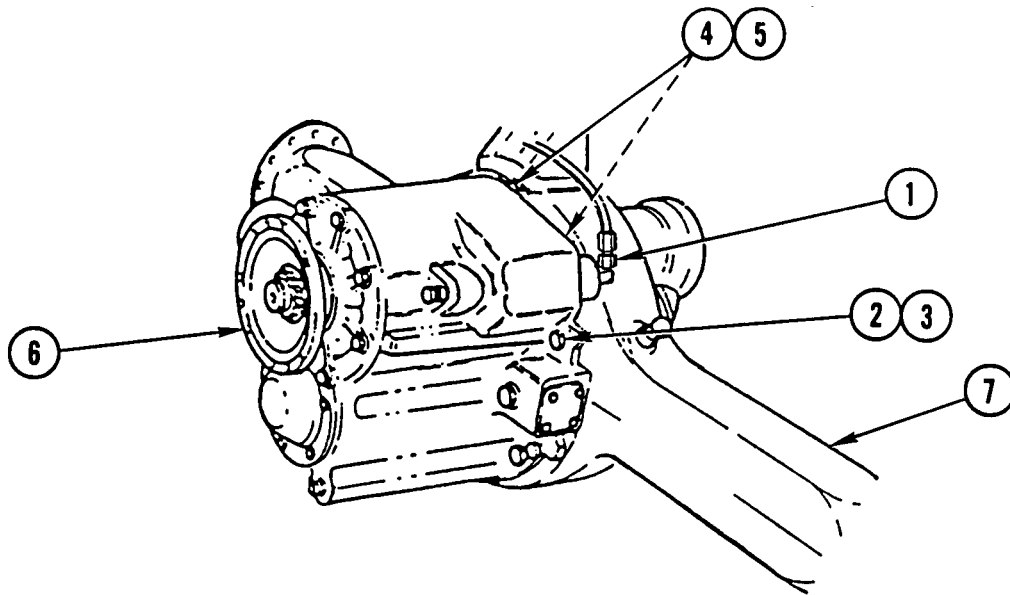
REMOVAL

1. DISCONNECT AIR LINE (1).

WARNING

Forward-rear axle differential carrier weighs 1,160 lb (526 kg). Attach suitable floor jack prior to removal to prevent possible injury to personnel.

NOTE

If axle assembly has been removed from vehicle, perform steps 2 and 3 only.

2. REMOVE 10 CAPSCREWS (2), 10 WASHERS (3), 2 NUTS (4), AND 2 WASHERS (5).
3. LOOSEN DIFFERENTIAL CARRIER (6) BY TAPPING AROUND FLANGE.
4. REMOVE DIFFERENTIAL CARRIER (6) FROM AXLE (7) AND LOWER DIFFERENTIAL CARRIER (6) ONTO FLOOR JACK. ROLL DIFFERENTIAL CARRIER (6) FROM UNDER VEHICLE.

FORWARD-REAR AXLE DIFFERENTIAL CARRIER REPLACEMENT (CONT)

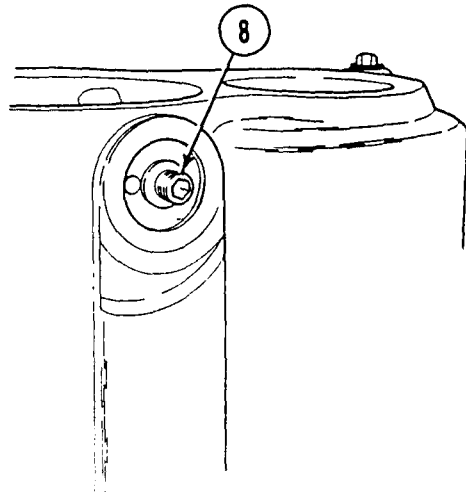

5. IF DAMAGED, REMOVE OIL FILTER ADAPTER (8).

CLEANING

Use general cleaning methods to clean all parts (page 2-30).

INSPECTION

Inspect all parts for wear or damage.

INSTALLATION

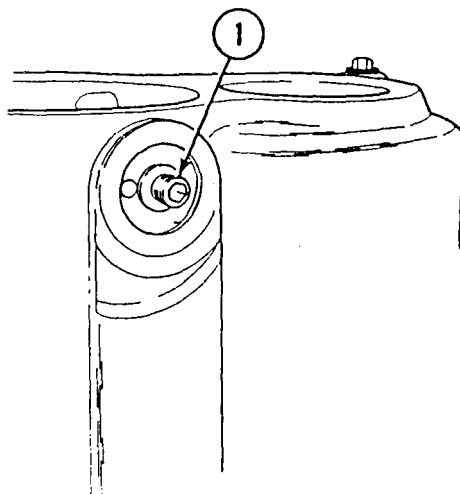

1. IF REMOVED, INSTALL NEW OIL FILTER ADAPTER (1).

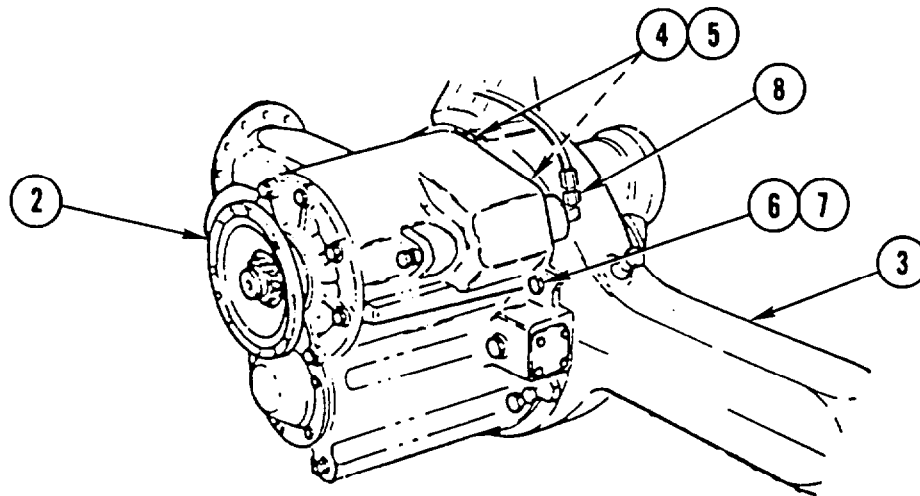

WARNING

Forward-rear axle differential carrier weighs 1,160 lb (526 kg). Attach suitable floor jack prior to installation to prevent possible injury to personnel.

CAUTION

Make sure both mating surfaces have been completely cleaned to prevent damage to equipment.

2. INSTALL DIFFERENTIAL CARRIER (2) ON FLOOR JACK AND ROLL DIFFERENTIAL CARRIER (2) INTO POSITION UNDER VEHICLE.

WARNING

Adhesives, solvents, and sealing compounds can burn easily, can give off harmful vapors, and are harmful to skin and clothing. To avoid injury or death, keep away from open fire and use in well-ventilated area. If adhesive, solvent, or sealing compound gets on skin or clothing, wash immediately with soap and water.

NOTE

If axle assembly has been removed from vehicle, perform steps 3 thru 5 only.

3. APPLY 1/8-IN. BEAD OF SEALING COMPOUND AROUND MATING SURFACE OF AXLE (3).
4. ATTACH SUITABLE HOIST AND INSTALL DIFFERENTIAL CARRIER (2), TWO WASHERS (4), AND TWO NUTS (5). DO NOT TIGHTEN NUTS,
5. INSTALL 10 WASHERS (6) AND 10 CAPSCREWS (7). TIGHTEN 10 CAPSCREWS (7) AND 2 NUTS (5) TO 150-230 LB-FT (203-312 N.m).
6. CONNECT AIR LINE (8).

NOTE

Follow-on Maintenance:

- Install output shaft (page 6-7).
- Install axle oil filter (TM 9-2320-363-20).
- Connect drivelines (TM 9-2320-363-20).
- Install grate (M916A1 and M916A2) (TM 9-2320-363-20).
- Install axle shafts (TM 9-2320-363-20).
- Fill axle with oil (TM 9-2320-363-20).

OUTPUT SHAFT REPLACEMENT AND REPAIR

This task covers: a. Removal b. Disassembly c. Cleaning d. Inspection e. Repair f. Assembly g. Installation

INITIAL SETUP

Tools and Special Equipment:

Shop Equipment, SC 4910-95-CL-A31
 Tool Kit, SC 5180-90-CL-N05

References:

TM 9-2320-363-20

Equipment Condition:

Materials/Parts:

Cup, Bearing (2) P/N JLM04910
 Cone, Bearing (2) P/N LM104949
 Adhesive-Sealant, Silicone Appendix B, Item 3

Reference	Condition	Description
TM 9-2320-363-20	Interaxle Driveline Removed	
Page 6-28	Rear Yoke and Oil Seal Removed (M915A2)	
Page 6-30	Rear Yoke and Oil Seal Removed (All except M915A2)	

REMOVAL

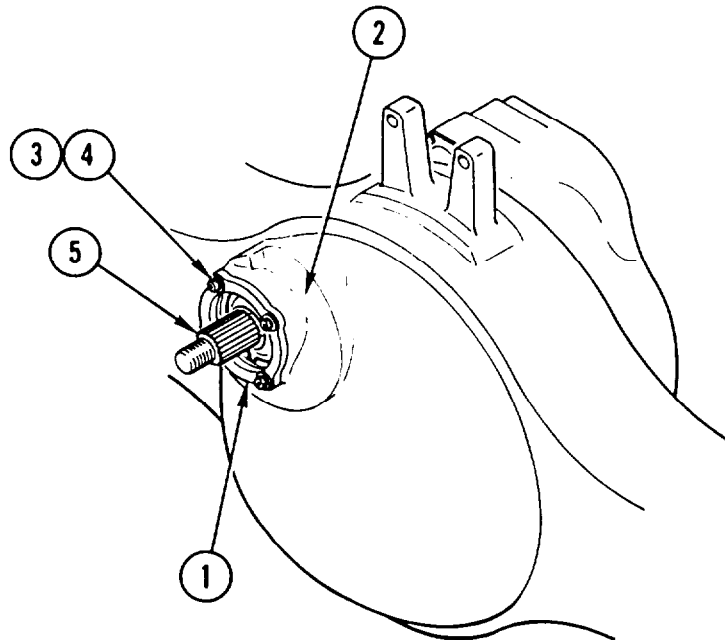

1. SCRIBE BEARING CAGE (1) AND AXLE HOUSING (2).
2. REMOVE FOUR SOCKET HEAD SCREWS (3), FOUR WASHERS (4), AND OUTPUT SHAFT ASSEMBLY (5).

OUTPUT SHAFT REPLACEMENT AND REPAIR (CONT)

DISASSEMBLY

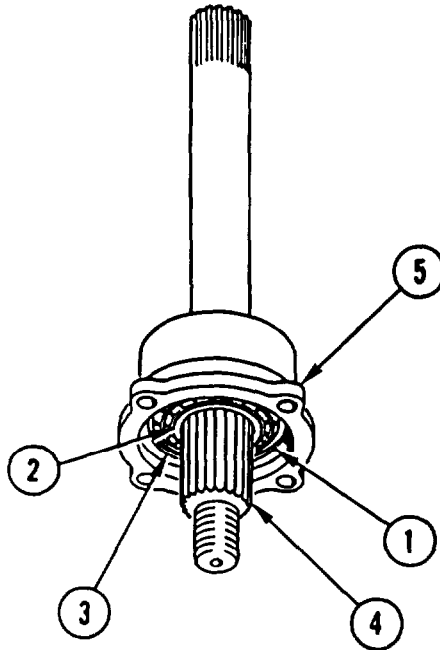

1. REMOVE OUTER SNAP RING (1) AND INNER SNAP RING (2).
2. REMOVE BEARING CUP (3) AND OUTPUT SHAFT (4) FROM BEARING CAGE (5). DISCARD BEARING CUP.

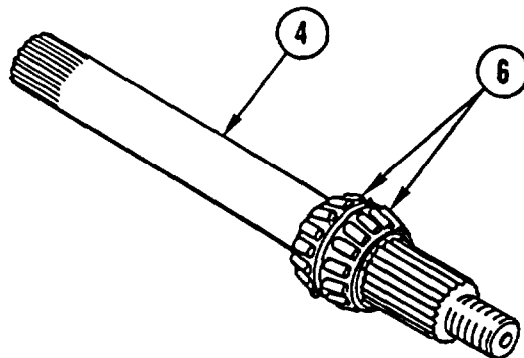

3. REMOVE AND DISCARD TWO BEARING CONES (6) FROM OUTPUT SHAFT (4).

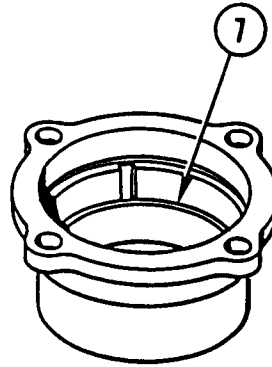

4. REMOVE AND DISCARD BEARING CUP (7).

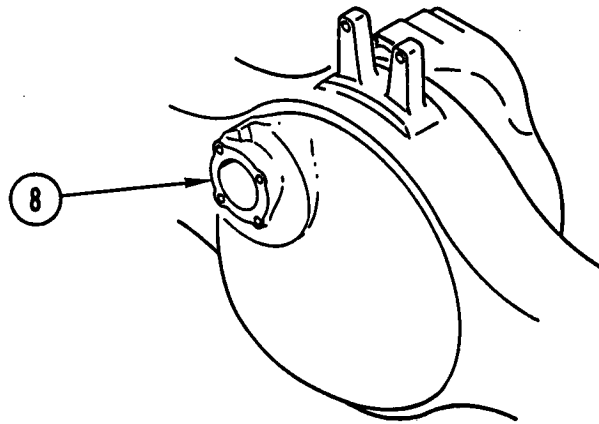

5. CLEAN MATING SURFACE OF AXLE (8).

CLEANING

Use general cleaning methods to clean all parts (page 2-30).

INSPECTION

1. INSPECT OUTER SNAP RING FOR DAMAGE. IF DAMAGED, MEASURE THICKNESS OF SNAP RING TO DETERMINE REQUIRED REPLACEMENT.
2. INSPECT ALL REMAINING PARTS FOR WEAR OR DAMAGE.

REPAIR

Use general repair methods to repair damaged parts (page 2-33).

OUTPUT SHAFT REPLACEMENT AND REPAIR (CONT)

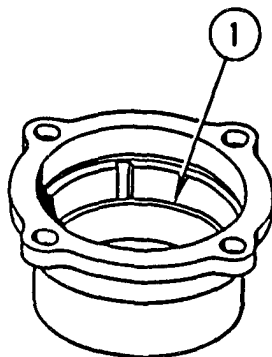

1. INSTALL NEW BEARING CUP (1).

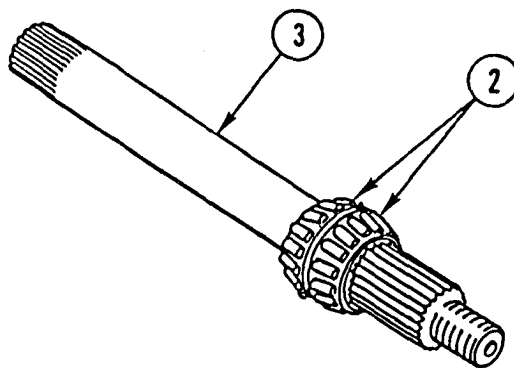

2. INSTALL TWO NEW BEARING CONES (2) ON OUTPUT SHAFT (3) UNTIL INNER CONE TOUCHES SHOULDER ON OUTPUT SHAFT (3).

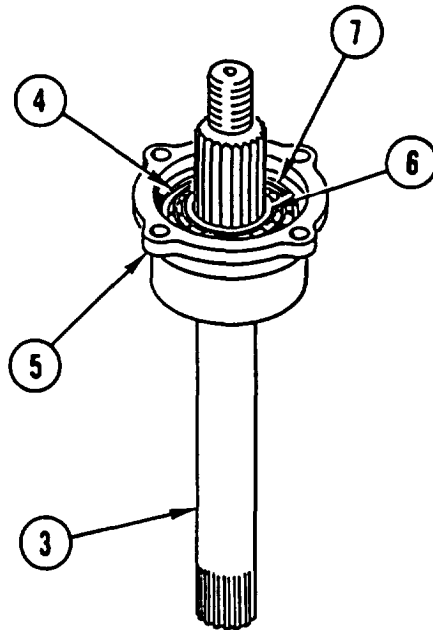

3. INSTALL OUTPUT SHAFT (3) AND NEW BEARING CUP (4) IN BEARING CAGE (5).
4. INSTALL INNER SNAP RING (6) AND OUTER SNAP RING (7).

INSTALLATION

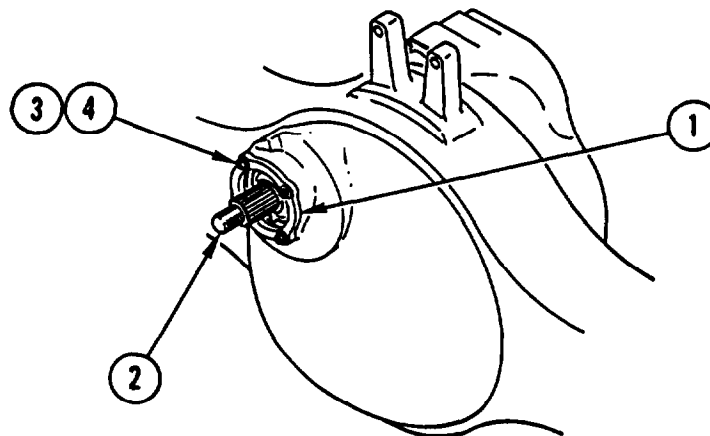

1. COAT MATING SURFACE OF AXLE (1) WITH SILICONE ADHESIVE-SEALANT.
2. INSTALL OUTPUT SHAFT ASSEMBLY (2) AS MARKED IN REMOVAL, FOUR WASHERS (3), AND FOUR SOCKET HEAD SCREWS (4). TIGHTEN SCREWS TO 35-50 LB-FT (47-68 N.m).

NOTE

Follow-on Maintenance:
 Install rear yoke and oil seal (M915A2) (page 6-28).
 Install rear yoke and oil seal (All except M915A2) (page 6-30).
 Install Interaxle driveline (TM 9-2320-363-20).

REAR-REAR AXLE DIFFERENTIAL CARRIER REPLACEMENT

This task covers: a. Removal b. Cleaning c. Inspection d. Installation

INITIAL SETUP

Tools and Special Equipment:

Shop Equipment, SC 4910-95-CL-A31
Tool Kit, SC 5180-90-CL-N05

Materials/Parts:

Washer, Lock (12) P/N 1229U1503
Compound, Sealing Appendix B, Item 16

Personnel Required: (2)

References:

TM 9-2320-363-20

Equipment Condition:

Reference	Condition Description
TM 9-2320-363-20	Axle Shafts Removed
TM 9-2320-363-20	Intermediate Driveline Disconnected
TM 9-2320-363-20	Axle Oil Drained

General Safety Instructions:

WARNING

- Rear-rear axle differential carrier weighs 860 lb (390 kg). Attach suitable floor jack prior to removal or installation to prevent possible injury to personnel.
- Adhesives, solvents, and sealing compounds can burn easily, can give off harmful vapors, and are harmful to skin and clothing. To avoid injury or death, keep away from open fire and use in well-ventilated area. If adhesive, solvent, or sealing compound gets on skin or clothing, wash immediately with soap and water.
- Spilled gear oil is very slippery. Wipe up any spilled oil immediately. Failure to do so could result in serious injury to personnel.

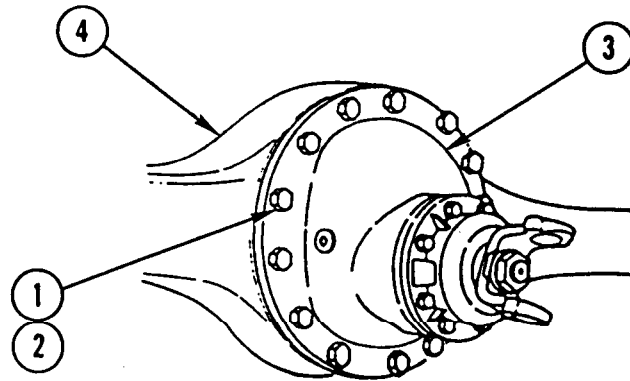
REMOVAL**WARNING**

- Rear-rear axle differential carrier weighs 860 lb (390 kg), Attach suitable floor jack prior to removal to prevent possible injury to personnel.
- Spilled gear oil is very slippery. Wipe up any spilled oil immediately. Failure to do so could result in serious injury to personnel.

NOTE

If axle assembly has been removed from vehicle, perform steps 1 thru 3 only.

1. REMOVE 12 CAPSCREWS (1) AND 12 LOCK WASHERS (2). DISCARD LOCK WASHERS.
2. LOOSEN DIFFERENTIAL CARRIER (3) BY TAPPING AROUND FLANGE.
3. REMOVE DIFFERENTIAL CARRIER (3) FROM AXLE (4). DISCARD LOCK WASHERS.
4. LOWER DIFFERENTIAL CARRIER (3) ONTO FLOOR JACK AND ROLL DIFFERENTIAL CARRIER (3) FROM UNDER VEHICLE.

CLEANING

Use general cleaning methods to clean all parts (page 2-30).

INSPECTION

Inspect all parts for wear or damage.

REAR-REAR AXLE DIFFERENTIAL CARRIER REPLACEMENT (CONT)

INSTALLATION

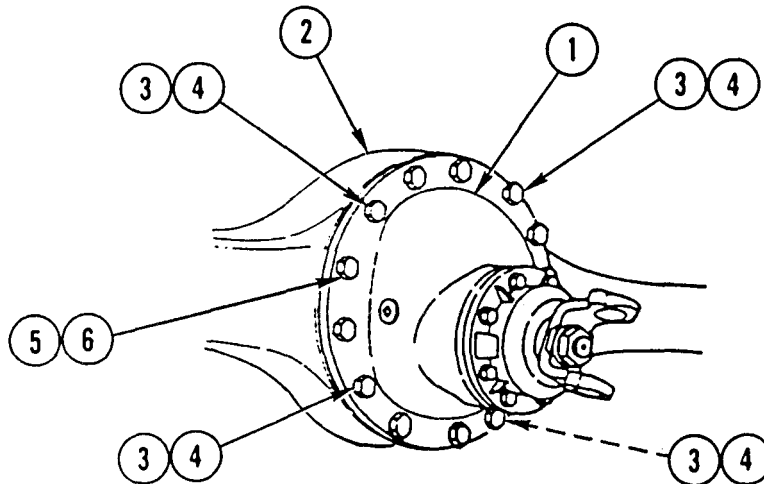

WARNING

Rear-rear axle differential carrier weighs 860 lb (390 kg), Attach suitable floor jack prior to installation to prevent possible injury to personnel.

NOTE

If axle assembly has been removed from vehicle, perform steps 2 thru 6 only.

1. INSTALL DIFFERENTIAL CARRIER (1) ON FLOOR JACK AND ROLL DIFFERENTIAL CARRIER (1) INTO POSITION UNDER VEHICLE.

WARNING

Adhesives, solvents, and sealing compounds can burn easily, can give off harmful vapors, and are harmful to skin and clothing, To avoid injury or death, keep away from open fire and use in well-ventilated area. If adhesive, solvent, or sealing compound gets on skin or clothing, wash immediately with soap and water.

CAUTION

Make sure both mating surfaces have been completely cleaned to prevent damage to equipment.

2. APPLY 1/8-IN. BEAD OF SEALING COMPOUND AROUND ENTIRE MATING SURFACE OF AXLE (2).

3. ATTACH SUITABLE HOIST AND INSTALL DIFFERENTIAL CARRIER (1), FOUR NEW LOCK WASHERS (3), AND FOUR CAPSCREWS (4) IN FOUR CORNER LOCATIONS AROUND DIFFERENTIAL CARRIER (1). HAND-TIGHTEN CAPSCREWS.
4. SEAT DIFFERENTIAL CARRIER (1) AND TIGHTEN FOUR CAPSCREWS (4) IN PATTERN OPPOSITE EACH OTHER.
5. REPEAT STEP 4 UNTIL DIFFERENTIAL CARRIER (1) IS COMPLETELY SEATED. TIGHTEN FOUR CAPSCREWS (4) TO 150-230 LB-FT (203-312 N.m).
6. INSTALL EIGHT NEW LOCK WASHERS (5) AND EIGHT CAPSCREWS (6). TIGHTEN EIGHT CAPSCREWS (6) TO 150-230 LB-FT (203-312 N.m).

NOTE

Follow-on Maintenance:

Connect intermediate driveline (TM 9-2320-363-20).

Install axle shafts (TM 9-2320-363-20).

Fill axle with oil (TM 9-2320-363-20).

REAR AXLE REPLACEMENT

This task covers: a. Removal b. Cleaning c. Inspection d. Installation

INITIAL SETUP

Applicable Configuration:

M915A2

Tools and Special Equipment:

Shop Equipment, SC 4910-95-CL-A31

Tool Kit, SC 5180-90-CL-N05

Materials/Parts:

Nut, Lock (16) P/N N-38-P

Nut, Lock (2)

Nut, Lock (2) P/N 30191

Personnel Required: (2)

References:

TM 9-2320-363-20

Equipment Condition:

Reference	Condition Description
TM 9-2320-363-20	Air System Drained
TM 9-2320-363-20	Rear Brakeshoes and Linings Removed
TM 9-2320-363-20	Drivelines Removed
TM 9-2320-363-20	Rear Anti-Lock Brake System (ABS) Sensors Removed
TM 9-2320-363-20	Axle Oil Drained

General Safety Instructions:

WARNING

Axle housing is heavy and can injure personnel if dropped. Support axle housing during removal or installation.

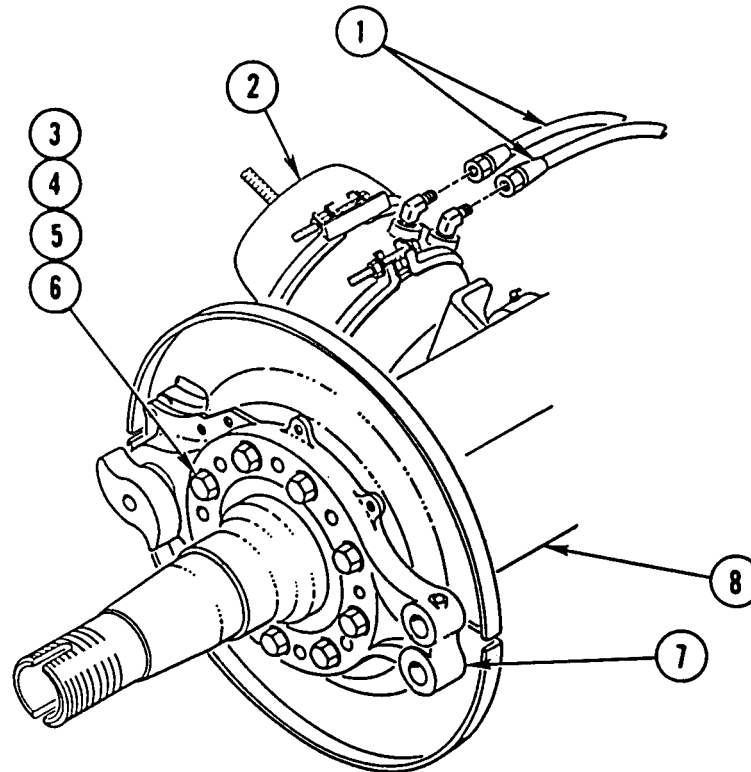
REMOVAL**WARNING**

Axle housing is heavy and can injure personnel if dropped. Support axle housing during removal.

NOTE

Procedure is the same for all rear axles except where noted.

1. DISCONNECT TWO AIR LINES (1) FROM BRAKE CHAMBER (2).

NOTE

Note position of spider assembly prior to removal to aid in installation.

2. REMOVE EIGHT LOCK NUTS (3), EIGHT WASHERS (4), EIGHT SCREWS (5), EIGHT WASHERS (6), AND SPIDER ASSEMBLY (7) FROM AXLE HOUSING (8). DISCARD LOCK NUTS.
3. REPEAT STEPS 1 AND 2 FOR OPPOSITE SIDE OF AXLE HOUSING (8).

REAR AXLE REPLACEMENT (CONT)

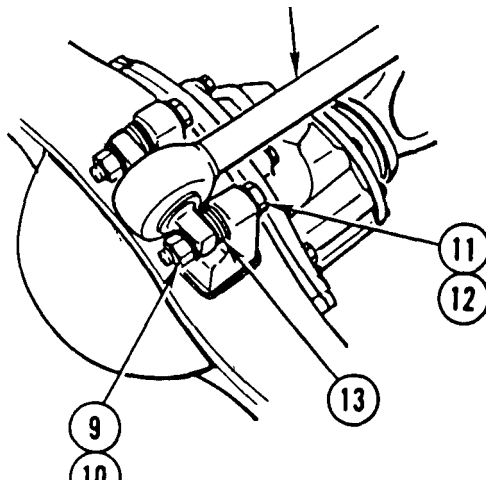

NOTE

If axle is to be reinstalled, tag spacers.

4. REMOVE TWO LOCK NUTS (9), TWO WASHERS (10) TWO SCREWS (11), TWO WASHERS (12), SPACER(S) (13) IF INSTALLED, AND TORQUE ROD (14). MOVE TORQUE ROD OUT OF THE WAY. DISCARD LOCK NUTS.

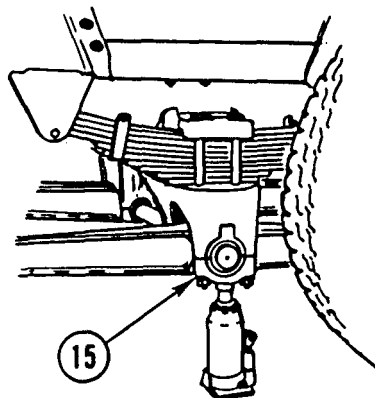

5. PLACE SUITABLE JACK UNDER EQUALIZING BEAM SADDLE CAP (15) AND RAISE TANDEM UNTIL COMPANION AXLES AND WHEELS ARE OFF THE GROUND. LOWER UNTIL WHEELS CANNOT BE ROTATED BY HAND.
6. REPEAT STEP 5 FOR OPPOSITE SIDE OF TANDEM.

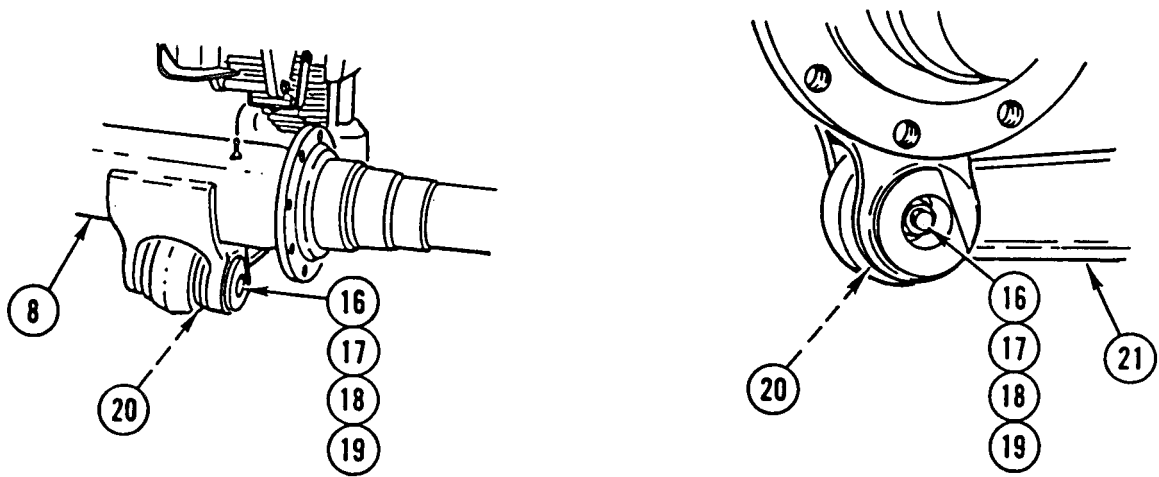

7. USING SUITABLE ROLLER JACK, SUPPORT AXLE HOUSING (8).
8. REMOVE LOCK NUT (16), WASHER (17), SCREW (18), WASHER (19), AND TWO BUSHINGS (20). DISCARD LOCK NUT.
9. REPEAT STEP 8 FOR OPPOSITE SIDE.
10. SEPARATE AXLE HOUSING (8) FROM EQUALIZING BEAM (21) AND MOVE AXLE HOUSING (8) FROM UNDER VEHICLE.

NOTE

If axle housing is being replaced, remove differential carrier assembly in accordance with page 6-1 for forward-rear axle or page 6-12 for rear-rear axle.

CLEANING

Use general cleaning methods to clean all parts (page 2-30).

INSPECTION

Inspect all parts for wear or damage.

REAR AXLE REPLACEMENT (CONT)

INSTALLATION

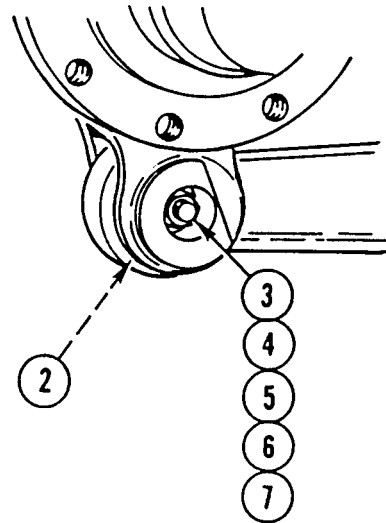
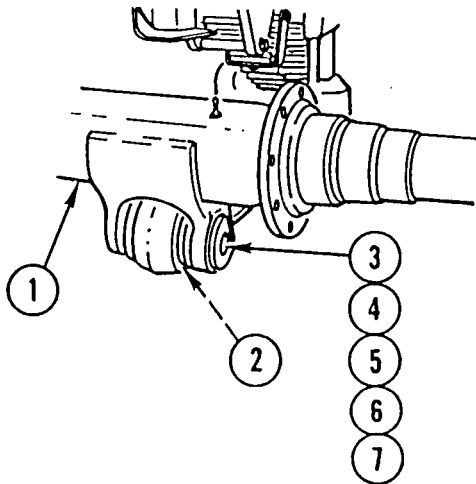

WARNING

Axle housing is heavy and can injure personnel if dropped. Support axle housing during installation.

NOTE

- Procedure is the same for all rear axles except where noted.
- If axle housing was replaced, install differential carrier assembly in accordance with page 6-1 for forward-rear axle or page 6-12 for rear-rear axle.

1. ALINE AXLE HOUSING (1) WITH EQUALIZING BEAM END BUSHING (2) AND INSTALL TWO BUSHINGS (3), WASHER (4), SCREW (5), WASHER (6), AND NEW LOCK NUT (7). TIGHTEN SCREW TO 210-240 LB-FT (285-325 N.m).
2. REPEAT STEP 1 FOR OPPOSITE SIDE.

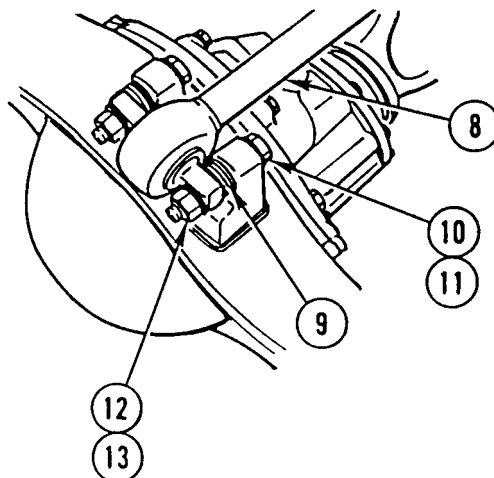

NOTE

If reinstalling axle, perform step 3. If installing new axle, perform step 4.

3. INSTALL TORQUE ROD (8), ANY SPACER(S) (9), TWO WASHERS (10), TWO SCREWS (11), TWO WASHERS (12), AND TWO NEW LOCK NUTS (13). TIGHTEN LOCK NUTS TO 120-152 LB-FT (163-206 N.m).
4. INSTALL TORQUE ROD (8), TWO WASHERS (10), TWO SCREWS (11), TWO WASHERS (12), AND TWO NEW LOCK NUTS (13). HAND-TIGHTEN LOCK NUTS.

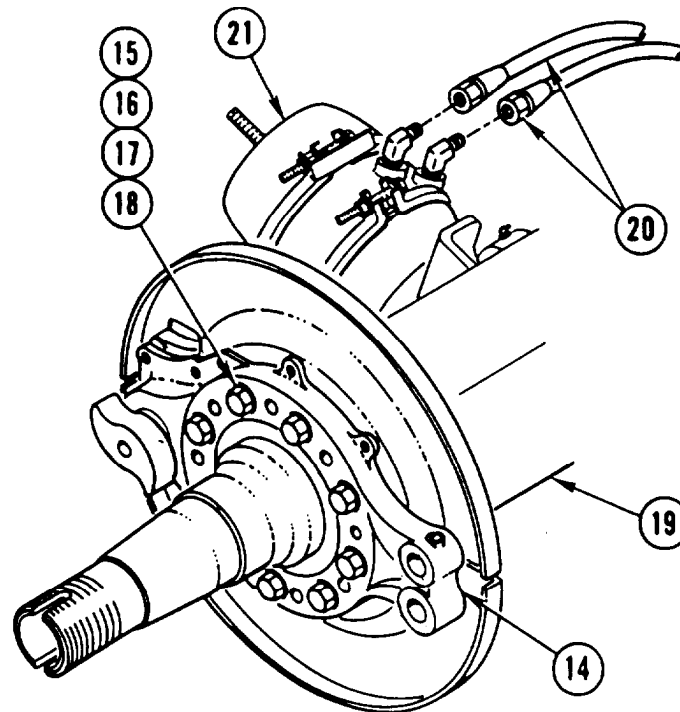

5. INSTALL SPIDER ASSEMBLY (14), EIGHT WASHERS (15), EIGHT SCREWS (16), EIGHT WASHERS (17), AND EIGHT NEW LOCK NUTS (18) ON AXLE HOUSING (19). TIGHTEN LOCK NUTS TO 135-145 LB-FT (183-197 N.m).
6. CONNECT TWO AIR LINES (20) IN BRAKE CHAMBER (21).

NOTE

Follow-on Maintenance:

- If new axle installed, adjust plane of axle (TM 9-2320-363-20).
- Install rear brakeshoes and linings (TM 9-2320-363-20).
- Fill axle with oil (TM 9-2320-363-20).
- Install rear Anti-Lock Brake System (ABS) sensors (TM 9-2320-363-20).

REAR AXLE REPLACEMENT

This task covers: a. Removal b. Cleaning c. Inspection d. Installation

INITIAL SETUP

Applicable Configuration:

All except M915A2

Tools and Special Equipment:

Shop Equipment, SC 4910-95-C-A31
Tool Kit, SC 5180-90-CL-N05

Materials/Parts:

Nut, Lock (32) P/N N-38-P

Nut, Lock (2) P/N 23-09901-114

Nut, Lock (2)

Nut, Lock (2)

Personnel Required: (2)

References:

TM 9-2320-363-20

Equipment Condition:

Reference	Condition	Description
TM 9-2320-363-20	Air System	Drained
TM 9-2320-363-20	Rear Brakeshoes and Linings	Removed
TM 9-2320-363-20	Drivelines	Removed
TM 9-2320-363-20	Axle Oil	Drained
Page 9-28	Equalizing Beam	Disconnected (All except M915A2 and M916A1)

General Safety Instructions:

WARNING

Axle housing is heavy and can injure personnel if dropped. Support axle housing during removal or installation.

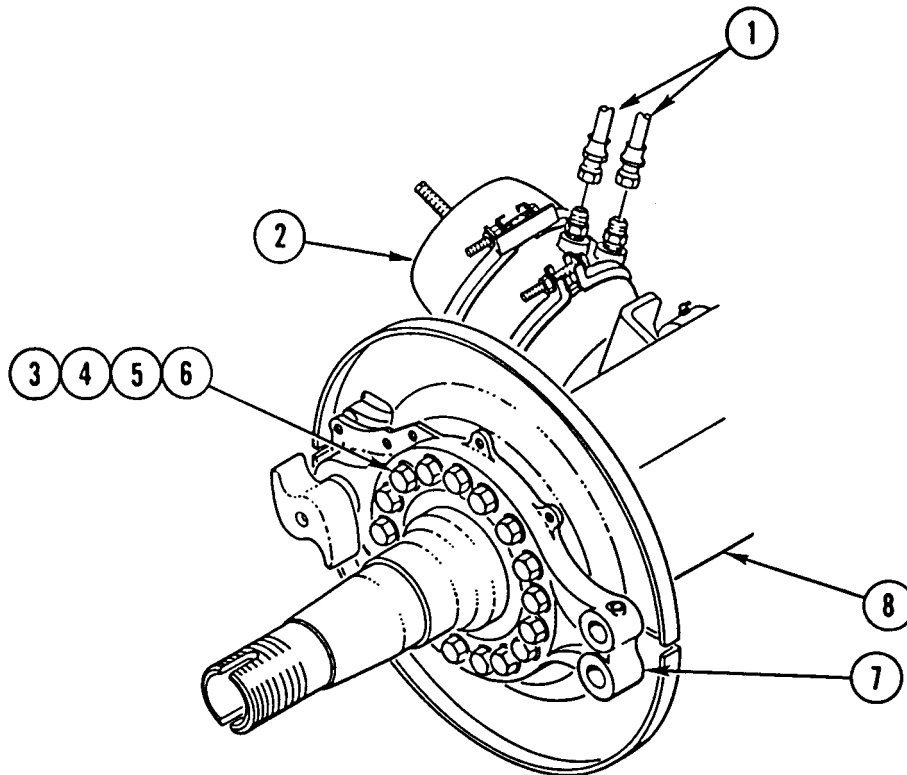
REMOVAL**WARNING**

Axle housing is heavy and can injure personnel if dropped. Support axle housing during removal.

NOTE

Procedure is the same for all rear axles except where noted.

1. DISCONNECT TWO AIR LINES (1) FROM BRAKE CHAMBER (2).

NOTE

Note position of brake spider prior to removal to aid in installation.

2. REMOVE 16 LOCK NUTS (3), 16 WASHERS (4), 16 SCREWS (5), 16 WASHERS (6), AND SPIDER ASSEMBLY (7) FROM AXLE HOUSING (8). DISCARD LOCK NUTS.
3. REPEAT STEPS 1 AND 2 FOR OPPOSITE SIDE OF AXLE HOUSING (8).

REAR AXLE REPLACEMENT (CONT)

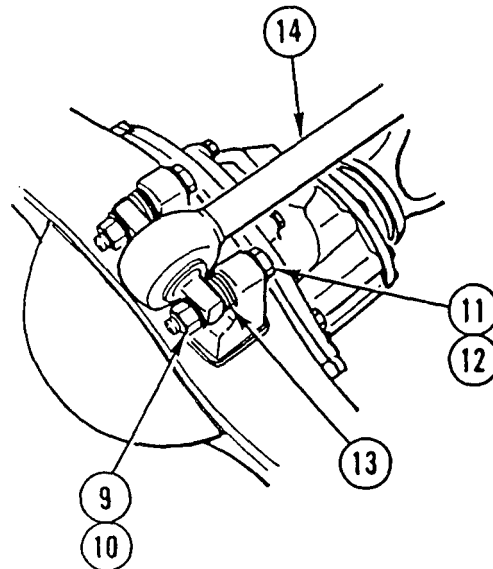

NOTE

If axle is to be reinstalled, tag spacers.

4. REMOVE TWO LOCK NUTS (9), TWO WASHERS (10), TWO SCREWS (11), TWO WASHERS (12), SPACER(S) (13) IF INSTALLED, AND TORQUE ROD (14). MOVE TORQUE ROD OUT OF THE WAY. DISCARD LOCK NUTS.

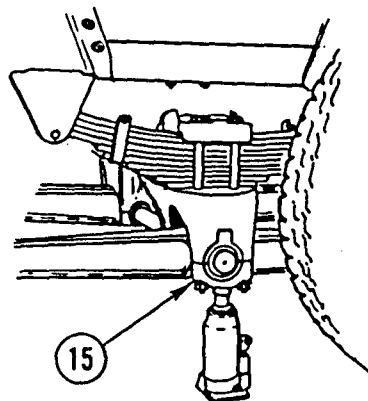

5. PLACE SUITABLE JACK UNDER EQUALIZING BEAM SADDLE CAP (15) AND RAISE TANDEM UNTIL COMPANION AXLES AND WHEELS ARE OFF THE GROUND. LOWER UNTIL WHEELS CANNOT BE ROTATED BY HAND.
6. REPEAT STEP 5 FOR OPPOSITE SIDE OF TANDEM.

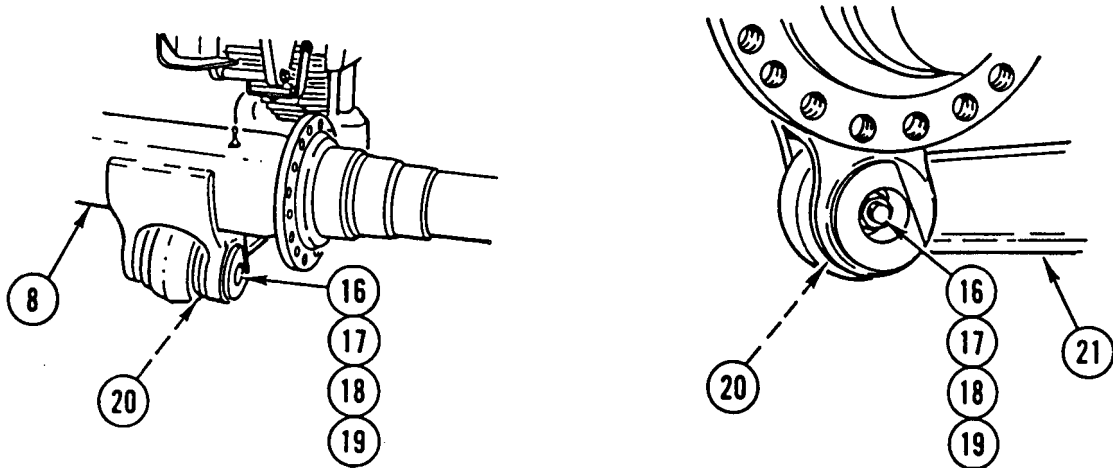

7. USING SUITABLE ROLLER JACK, SUPPORT AXLE HOUSING (8).
8. REMOVE LOCK NUT (16), WASHER (17), SCREW (18), WASHER (19), AND TWO BUSHINGS (20). DISCARD LOCK NUT.
9. REPEAT STEP 8 FOR OPPOSITE SIDE.
10. SEPARATE AXLE HOUSING (8) FROM EQUALIZING BEAM (21) AND MOVE AXLE HOUSING (8) FROM UNDER VEHICLE.

NOTE

If axle housing is to be replaced, remove differential carrier assembly in accordance with page 6-1 for forward-rear axle or page 6-12 for rear-rear axle.

CLEANING

Use general cleaning methods to clean all parts (page 2-30).

INSPECTION

Inspect all parts for wear or damage.

REAR AXLE REPLACEMENT (CONT)

INSTALLATION

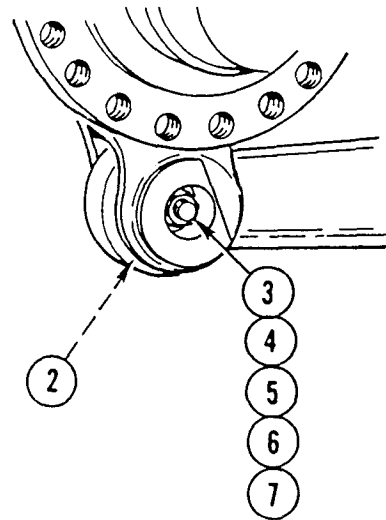
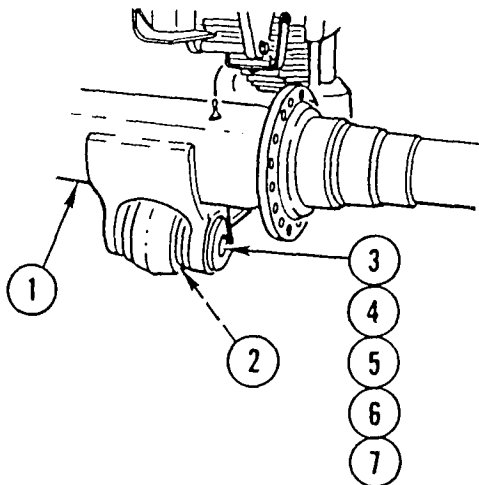

WARNING

Axle housing is heavy and can injure personnel if dropped. Support axle housing during installation.

NOTE

- Procedure is the same for all rear axles except where noted.
- If axle housing was replaced, install differential carrier assembly in accordance with page 6-1 for forward-rear axle or page 6-12 for rear-rear axle.

1. ALINE AXLE HOUSING (1) WITH EQUALIZING BEAM END BUSHING (2) AND INSTALL TWO BUSHINGS (3), WASHER (4), SCREW (5), WASHER (6), AND NEW LOCK NUT (7). TIGHTEN SCREW TO 445-495 LB-FT (603-671 N.m).
2. REPEAT STEP 1 FOR OPPOSITE SIDE.

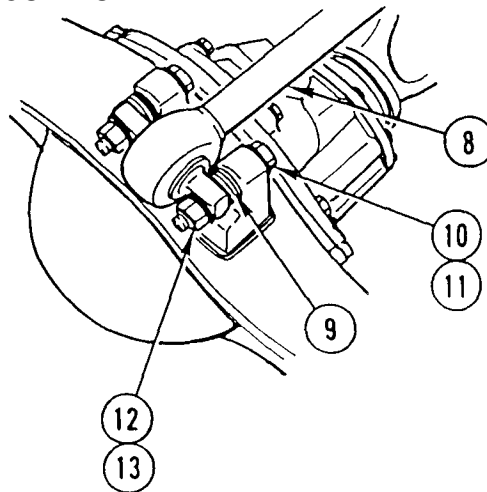

NOTE

If reinstalling axle, perform step 3. If installing new axle, perform step 4.

3. INSTALL TORQUE ROD (8), ANY SPACER(S) (9), TWO WASHERS (10), TWO SCREWS (11), TWO WASHERS (12), AND TWO NEW LOCK NUTS (13). TIGHTEN LOCK NUTS TO 342-434 LB-FT (464-588 N.m).
4. INSTALL TORQUE ROD (8), TWO WASHERS (10), TWO SCREWS (11), TWO WASHERS (12), AND TWO NEW LOCK NUTS (13). HAND-TIGHTEN LOCK NUTS.

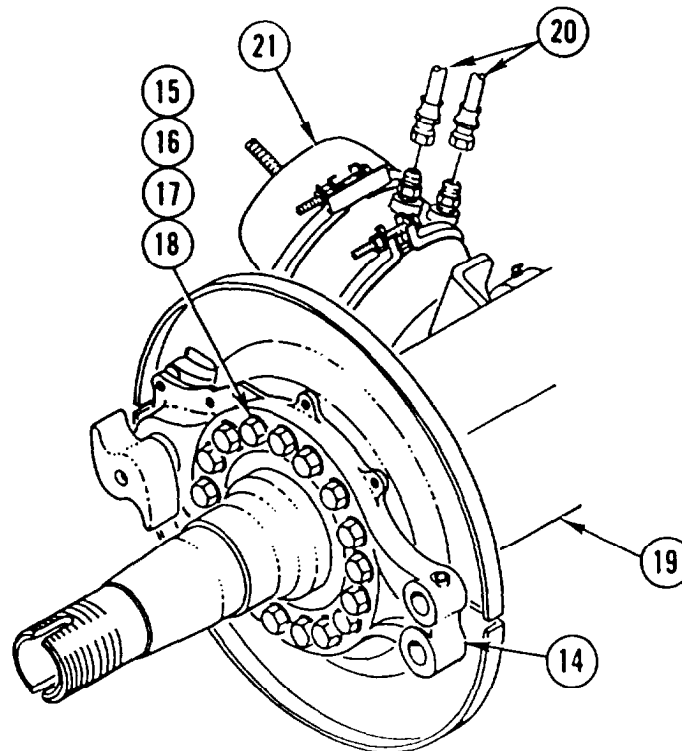

5. INSTALL SPIDER ASSEMBLY (14), 16 WASHERS (15), 16 SCREWS (16), 16 WASHERS (17), AND 16 NEW LOCK NUTS (16), ON AXLE HOUSING (19). TIGHTEN LOCK NUTS TO 135-145 LB-FT (183-197 N.m).
6. CONNECT TWO AIR LINES (20) IN BRAKE CHAMBER (21).

NOTE

Follow-on Maintenance:

- Connect equalizing beam (all except M915A2 and M916A1) (page 9-28).
- If new axle was installed, adjust plane of axle (TM 9-2320-363-20).
- Install rear brakeshoes and linings (TM 9-2320-363-20).
- Fill axle with oil (TM 9-2320-363-20).

REAR YOKE AND OIL SEAL REPLACEMENT

This task covers: a. Removal b. Cleaning c. Inspection d. Installation

INITIAL SETUP

Applicable Configuration:

M915A2

Personnel Required: (2)

References:

Tools and Special Equipment:

TM 9-2320-363-20

Shop Equipment, SC 4910-95-CL-A31

Tool Kit, SC 5180-90-CL-N05

Yoke Holder Bar, J3453

Equipment Condition:

Materials/Parts:

Reference

Condition Description

Seal, P/N A-1205-W-1895
Input FWD-Rear

TM 9-2320-363-20

Driveline Removed

Seal, P/N A-1205-W-1895
Output FWD-Rear

Seal, P/N A-1205-Y-1897
Input Rear-Rear

Nut, Flanged P/N 40X-1026

Oil, Lubricating Appendix B, Item 37

REMOVAL

1. USING YOKE HOLDER BAR, REMOVE FLANGED NUT (1) AND YOKE (2). DISCARD FLANGED NUT.
2. REMOVE AND DISCARD OIL SEAL (3) FROM DIFFERENTIAL SHAFT (4).

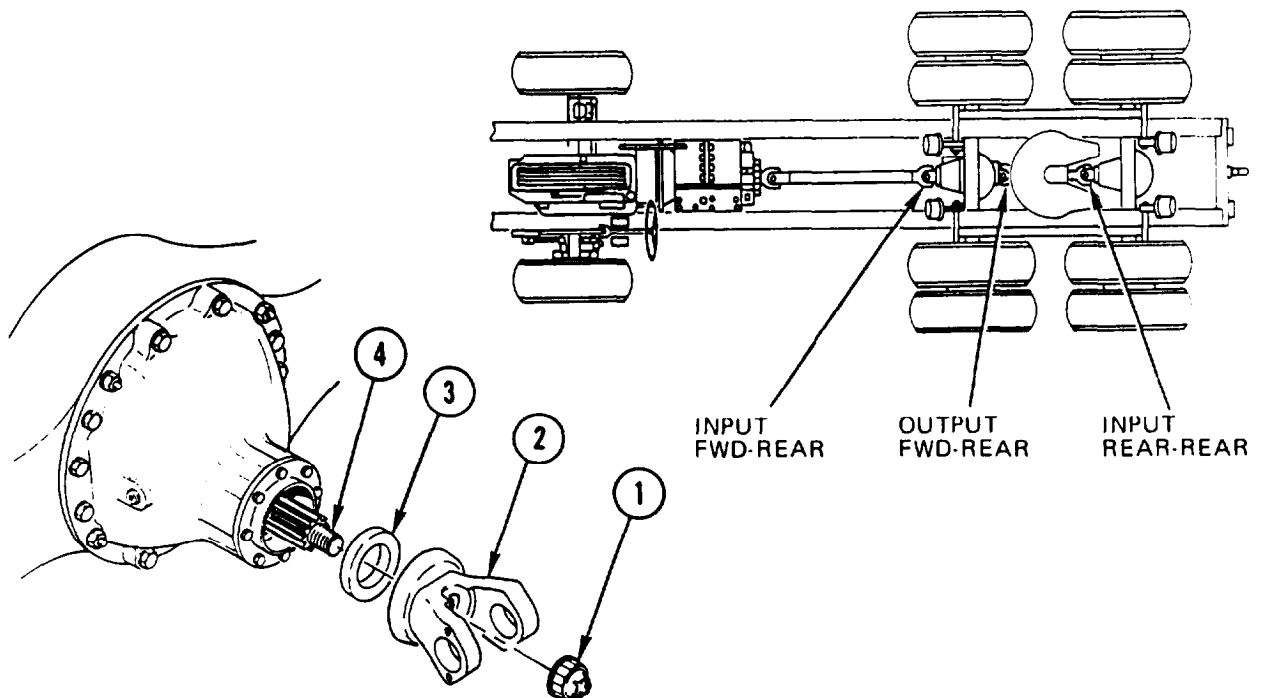

CLEANING

Use general cleaning methods to clean all parts (page 2-30).

INSPECTION

Inspect all parts for wear or damage.

INSTALLATION

1. APPLY LUBRICATING OIL TO NEW OIL SEAL (3) AND INSTALL OIL SEAL (3).
2. INSTALL YOKE (2) ON DIFFERENTIAL SHAFT (4).
3. USING YOKE HOLDER BAR, INSTALL NEW FLANGED NUT (1) ON DIFFERENTIAL SHAFT (4). TIGHTEN NUT TO 450-600 LB-FT (610-814 N.m) ON INPUT FWD-REAR AND OUTPUT FWD-REAR, AND TIGHTEN TO 996-1,232 LB-FT (1350-1670 N.m) ON INPUT REAR-REAR.

NOTE

Follow-on Maintenance:

Install driveline (TM 9-2320-363-20).

Fill axle with oil (TM 9-2320-363-20).

REAR YOKE AND OIL SEAL REPLACEMENT

This task covers: a. Removal b. Cleaning c. Inspection d. Installation

INITIAL SETUP

Applicable Configuration:

All except M915A2

Tools and Special Equipment:

Shop Equipment, SC 4910-95-CL-A31

Tool Kit, SC 5180-90-CL-N05

Yoke Holder Bar, J3453

Materials/Parts:

Seal, P/N A-1205-B-1926
Input FWD-Rear

Seal, P/N A-1205-W-1895
Output FWD-Rear

Seal, P/N A-1205-U-1945
Input Rear-Rear

Nut, Flanged, P/N 40X-1026
Input FWD-Rear

Nut, Flanged, P/N 40X-1026
Output FWD-Rear

Nut, Flanged, P/N 450TA5
Input Rear-Rear

Oil, Lubricating Appendix B, Item 37

Personnel Required: (2)

References:

TM 9-2320-363-20

Equipment Condition:

Reference	Condition	Description
TM 9-2320-363-20	Driveline	Removed

REMOVAL

1. USING YOKE HOLDER BAR, REMOVE FLANGED NUT (1) AND YOKE (2). DISCARD FLANGED NUT.
2. REMOVE AND DISCARD OIL SEAL (3).

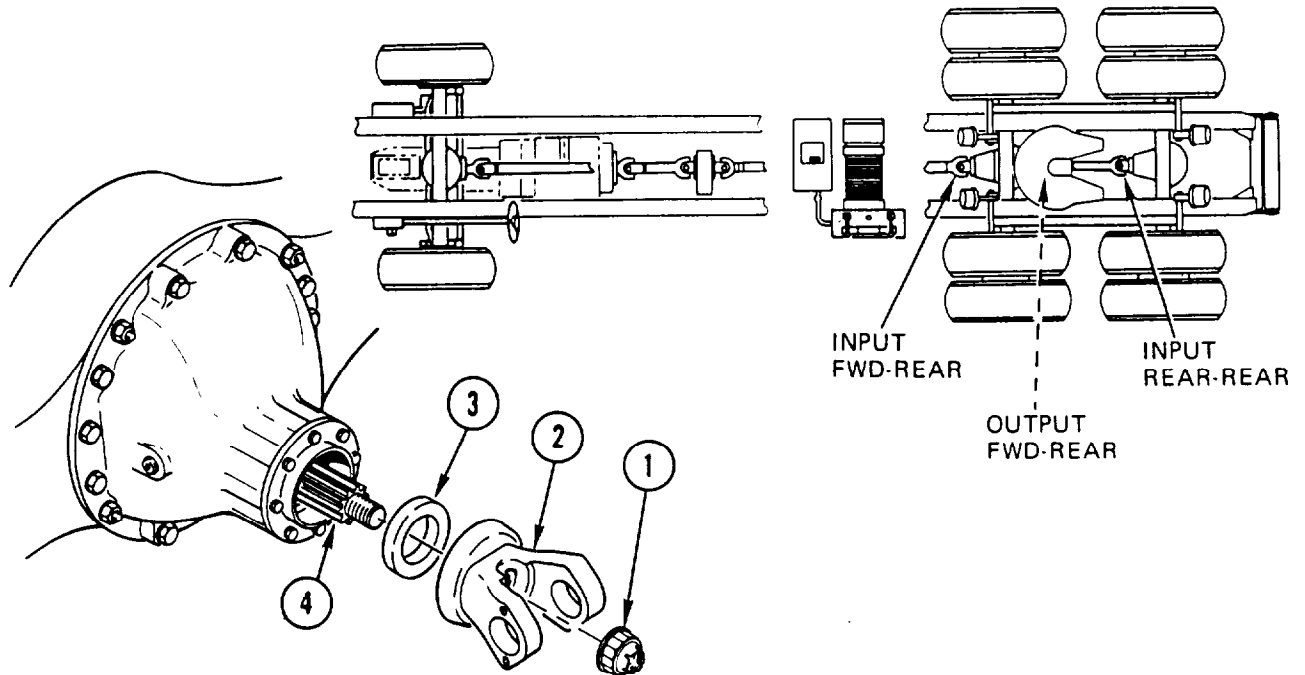

CLEANING

Use general cleaning methods to clean all parts (page 2-30).

INSPECTION

Inspect all parts for wear or damage

INSTALLATION

1. APPLY LUBRICATING OIL TO NEW OIL SEAL (3) AND INSTALL OIL SEAL (3).
2. INSTALL YOKE (2) ON DIFFERENTIAL SHAFT (4).
3. USING YOKE HOLDER BAR, INSTALL NEW FLANGED NUT (1) ON DIFFERENTIAL SHAFT (4). TIGHTEN NUT TO 450-600 LB-FT (610-814 N.m) ON INPUT FWD-REAR AND OUTPUT FWD-REAR, AND TIGHTEN TO 996-1,232 LB-FT (1350-1670 N.m) ON INPUT REAR-REAR.

NOTE

Follow-on Maintenance:

Install driveline (TM 9-2320-363-20).

Fill axle with oil (TM 9-2320-363-20).

CHAPTER 7 STEERING MAINTENANCE

OVERVIEW

This chapter illustrates and describes procedures for maintenance of the steering and related parts. A list of tasks contained in this chapter is shown below.

	Page
Power Steering Pump Replacement	7-2
Steering Gear Replacement	7-4

POWER STEERING PUMP REPLACEMENT

This task covers: a. Removal b. Cleaning c. Inspection d. Installation

INITIAL SETUP

Tools and Special Equipment:

Shop Equipment, SC 4910-95-CL-A31
 Tool Kit, SC 5180-90-CL-N05

Materials/Parts:

Ring, Seal P/N ER-8913-041
 (M915A2 and M916A1)

Gasket (All except P/N 8929299
 M915A2 and M916A1)

Washer, Lock (6)

Oil, Lubricating Appendix B, Item 37

References:

TM 9-2320-363-20

Equipment Condition:

Reference	Condition	Description
TM 9-2320-363-20	Vehicle	Blocked
TM 9-2320-363-20	Power Steering Reservoir	Drained

REMOVAL

NOTE

Perform step 1 only if gear case cover is to be removed.

1. REMOVE SCREW (1) AND CLAMP (2) FROM GEAR CASE COVER (3).
2. DISCONNECT STEERING GEAR HOSE (4) AND POWER STEERING RESERVOIR HOSE (5) FROM POWER STEERING PUMP (6).
3. REMOVE SIX CAPSCREWS (7) AND SIX LOCK WASHERS (8) FROM POWER STEERING PUMP (6). DISCARD LOCK WASHERS.
4. REMOVE POWER STEERING PUMP (6) FROM GEAR CASE COVER (3).
5. REMOVE POWER STEERING DRIVE COUPLING (9) FROM AIR COMPRESSOR DRIVE GEAR (10).
6. REMOVE SEAL RING (11) (DDEC II) OR GASKET (11.1) (DDEC III) FROM POWER STEERING PUMP (6). DISCARD SEAL RING OR GASKET.

CLEANING

Use general cleaning methods to clean all parts (page 2-30).

INSPECTION

Inspect all parts for wear or damage.

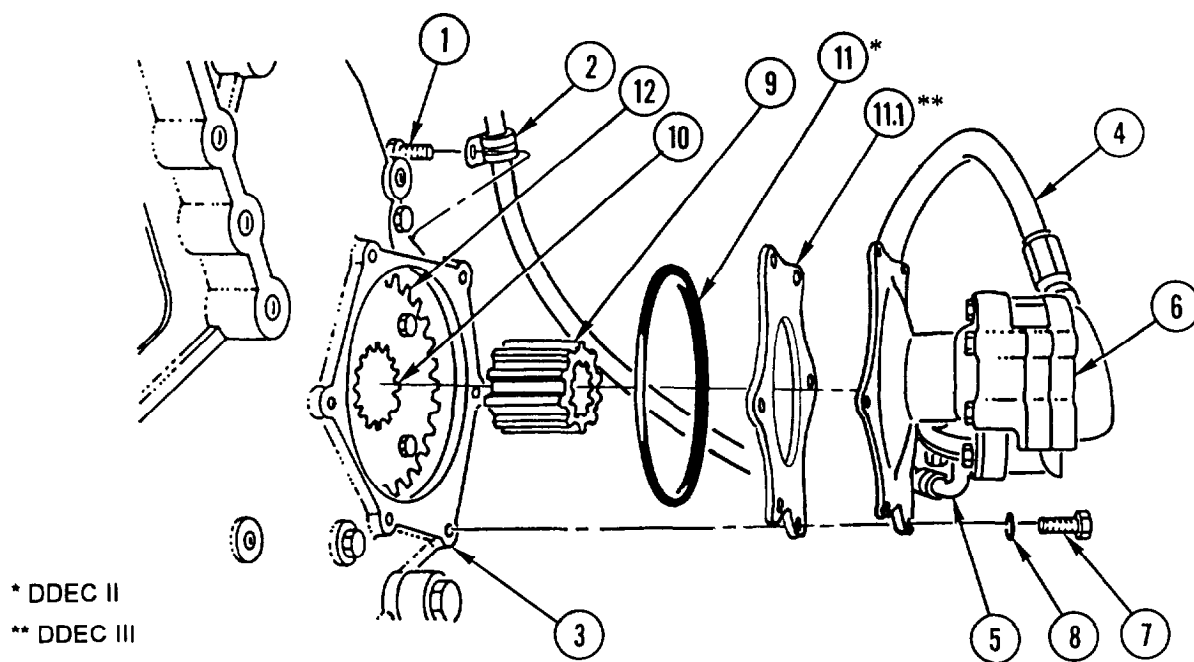

INSTALLATION

1. APPLY OIL AND INSTALL NEW SEAL RING (11) (DDEC II) OR NEW GASKET (11.1) (DDEC III) ON POWER STEERING PUMP (6).

CAUTION

Align power steering drive coupling (9) on air compressor drive gear and power steering pump gear properly. Failure to do so may cause damage to engine components.

2. INSTALL POWER STEERING DRIVE COUPLING (9) ON AIR COMPRESSOR DRIVE GEAR (10) AND POWER STEERING GEAR (12).
3. INSTALL POWER STEERING PUMP (6) ON GEAR CASE COVER (3).
4. INSTALL SIX NEW LOCK WASHERS (8) AND SIX CAPSCREWS (7) ON POWER STEERING PUMP (6). TIGHTEN CAPSCREWS TO 22-28 LB-FT (30-38 N.m) USING CRISSCROSS PATTERN STARTING WITH BOTTOM-LEFT-CORNER CAPSCREW.
5. IF DISCONNECT, CONNECT STEERING GEAR HOSE (4) AND POWER STEERING RESERVOIR HOSE (5) TO POWER STEERING PUMP (6).
6. IF REMOVED, INSTALL CLAMP (2) AND SCREW (1) ON GEAR CASE COVER (3).

NOTE

Follow-on Maintenance:
Fill power steering reservoir (TM 9-2320-363-20).

STEERING GEAR REPLACEMENT

This task covers: a. Removal b. Cleaning c. Inspection d. Installation

INITIAL SETUP

Tools and Special Equipment:

Shop Equipment, SC 4910-95-CL-A31
 Tool Kit, SC 5180-90-CL-N05

Materials/Parts:

Nut, Lock
 Nut, Lock (2) P/N 23-09901-114
 Washer, Lock
 Packing
 Packing

Personnel Required: (2)

References:

TM 9-2320-363-10
 TM 9-2320-363-20

Equipment Condition:

Reference	Condition	Description
TM 9-2320-363-10	Vehicle Parked with Wheels Pointed Straight Ahead	
TM 9-2320-363-20	Drag Link Removed	

General Safety Instructions:

WARNING

Spilled power steering fluid is very slippery. Wipe up any spilled fluid immediately. Failure to do so could result in serious injury to personnel.

REMOVAL

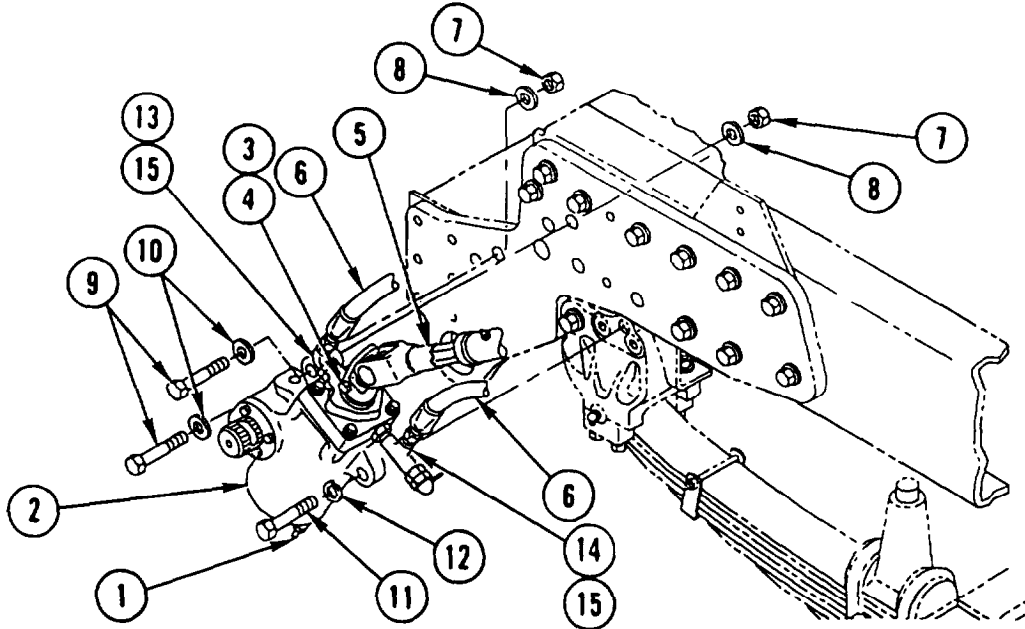

W A R N I N G

Spilled power steering fluid is very slippery. Wipe up any spilled fluid immediately. Failure to do so could result in serious injury to personnel.

1. REMOVE PLUG (1) FROM STEERING GEAR (2) AND DRAIN POWER STEERING FLUID INTO SUITABLE CONTAINER.
2. INSTALL PLUG (1) IN STEERING GEAR (2).
3. REMOVE LOCK NUT (3) AND BOLT (4) AND DISCONNECT LOWER UNIVERSAL SHAFT (5) FROM STEERING GEAR (2). DISCARD LOCK NUT.

NOTE

Oil will be present when hoses are removed.

4. DISCONNECT TWO HOSES (6) FROM STEERING GEAR (2).

NOTE

- Support steering gear during removal.
- Tag screw location during removal to aid in installation.

5. REMOVE TWO LOCK NUTS (7), TWO WASHERS (8), TWO SCREWS (9), AND TWO WASHERS (10). DISCARD LOCK NUTS.
6. REMOVE SCREW (11), LOCK WASHER (12), AND STEERING GEAR (2). DISCARD LOCK WASHER.
7. REMOVE ELBOW (13), TEE (14), AND TWO PACKINGS (15) FROM STEERING GEAR (2). DISCARD PACKINGS.

CLEANING

Use general cleaning methods to clean all parts (page 2-30).

INSPECTION

Inspect all parts for wear or damage

STEERING GEAR REPLACEMENT (CONT)

INSTALLATION

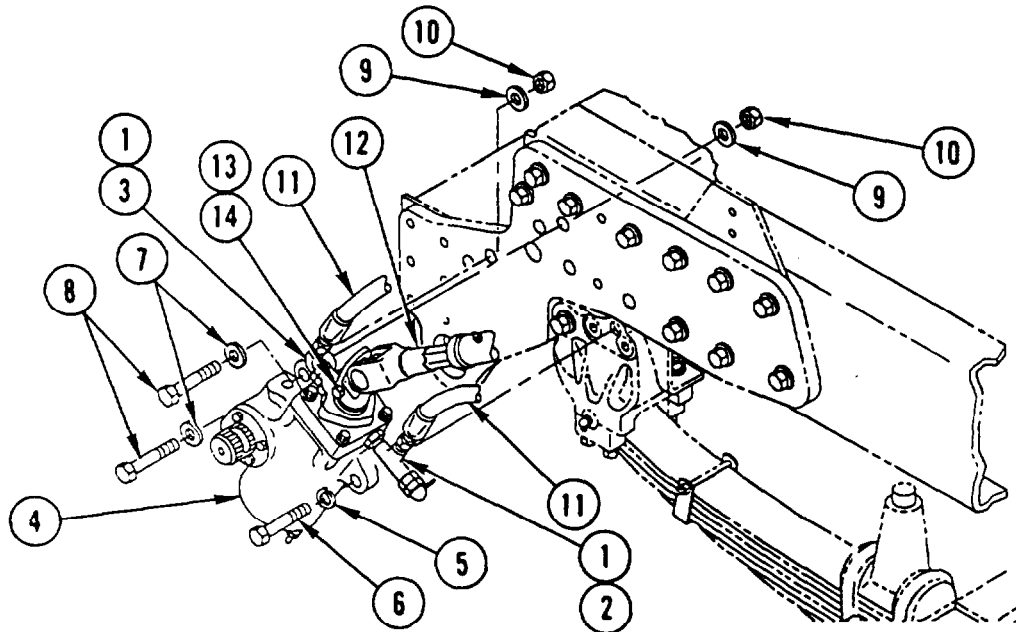

1. INSTALL TWO NEW PACKINGS (1), TEE (2), AND ELBOW (3) ON STEERING GEAR (4).

NOTE

Support steering gear during installation.

2. INSTALL STEERING GEAR (4), NEW LOCK WASHER (5), AND SCREW (6).
3. INSTALL TWO WASHERS (7), TWO SCREWS (8), TWO WASHERS (9), AND TWO NEW LOCK NUTS (10). TIGHTEN LOCK NUTS TO 344-466 LB-FT (466-632 N.m).

WARNING

Spilled power steering fluid is very slippery. Wipe up any spilled fluid immediately. Failure to do so could result in serious injury to personnel.

4. CONNECT TWO HOSES (11) ON STEERING GEAR (4).
5. CONNECT LOWER UNIVERSAL SHAFT (12) TO STEERING GEAR (4) AND INSTALL BOLT (13) AND NEW LOCK NUT (14).

NOTE

Follow-on Maintenance:

Install drag link (TM 9-2320-363-20).

Fill power steering reservoir (TM 9-2320-363-20).

CHAPTER 8
FRAME AND TOWING ATTACHMENTS MAINTENANCE

OVERVIEW

This chapter illustrates and describes procedures for maintenance of the suspension and related parts. A list of tasks contained in this chapter is shown below.

	Page
Frame Rail Extension and Reinforcement Replacement.....	8-2
Front Engine Mount Support Replacement.....	8-7
Front Crossmember Replacement.....	8-10
Rear Crossmember Assembly Replacement (M915A2).....	8-15
Rear Crossmember Assembly Replacement (All Except M915A2).....	8-20
Overslung Crossmember Replacement.....	8-25
Cab Alligator Crossmember Replacement (M915A2).....	8-28
Cab Alligator Crossmember Replacement (All Except M915A2).....	8-37
Midships Alligator Crossmember Replacement (M915A2).....	8-46
Midships Alligator Crossmember Replacement (All Except M915A2).....	8-54
Rear Suspension Crossmember Replacement (M915A2).....	8-62
Rear Suspension Crossmember Replacement (All Except M915A2).....	8-67

FRAME RAIL EXTENSION AND REINFORCEMENT REPLACEMENT

This task covers: a. Removal b. Cleaning c. Inspection d. Installation

INITIAL SETUP

Tools and Special Equipment:

Shop Equipment, SC 4910-95-CL-A31
 Tool Kit, SC 5180-90-CL-N05

Personnel Required: (3)

References:

TM 9-2320-363-20

Equipment Condition:

Reference	Condition Description
TM 9-2320-363-20	Power Steering Reservoir and Hoses Removed
TM 9-2320-363-20	Water Filter Adapter and Bracket Removed
TM 9-2320-363-20	Transmission Oil Cooler Removed
Page 8-10	Front Crossmember Removed

Equipment Condition (Cont):

Reference	Condition Description
Page 9-8	Front Spring Hangers Removed
Page 8-7	Front Engine Mount Support Removed

General Safety Instructions:

WARNING

Frame rail reinforcement weighs 100 lb (45.4 kg). Use minimum of three personnel to remove or install parts from or on frame rail reinforcement. Failure to do so could result in injury to personnel.

REMOVAL

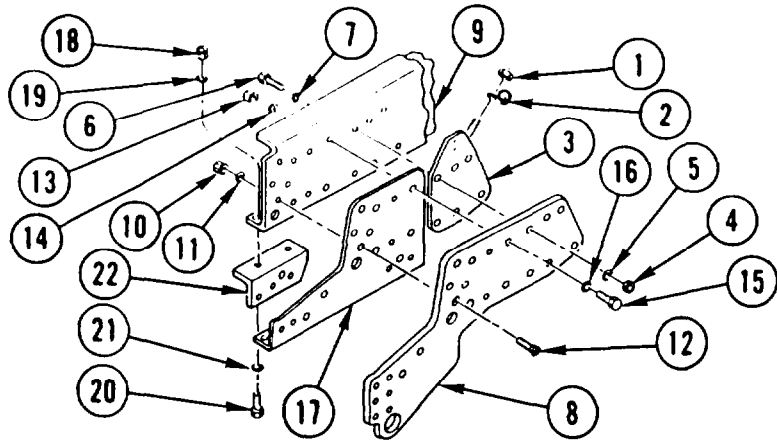
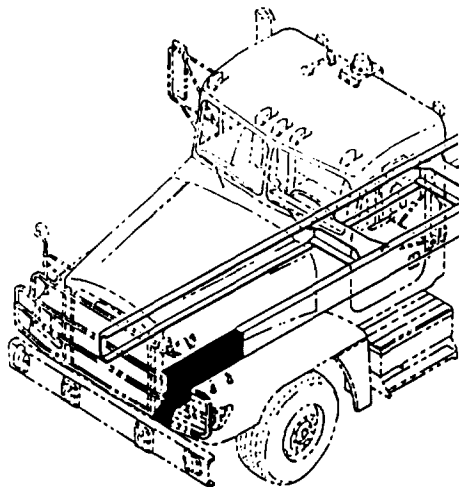

NOTE

- Steps 1 thru 9 are for left side only.
- Steps 10 thru 16 are for right side only.

1. REMOVE NUT (1) AND CLAMP (2) FROM POWER STEERING RESERVOIR PLATE (3),

NOTE

Note position of capscrews prior to removal to aid in installation.

2. REMOVE SIX NUTS (4), SIX WASHERS (5), SIX CAPSCREWS (6), AND SIX WASHERS (7).
3. REMOVE POWER STEERING RESERVOIR PLATE (3) FROM BETWEEN FRAME RAIL REINFORCEMENT (8) AND FRAME RAIL (9).
4. INSTALL ANY TWO WASHERS (7), TWO CAPSCREWS (6), TWO WASHERS (5), AND TWO NUTS (4) HAND-TIGHT IN FRAME RAIL REINFORCEMENT (8) AND FRAME RAIL (9).
5. REMOVE TWO NUTS (10), TWO WASHERS (11), AND TWO SCREWS (12).
6. REMOVE THREE NUTS (13), THREE WASHERS (14), THREE CAPSCREWS (15), AND THREE WASHERS (16).
7. REMOVE FRAME RAIL EXTENSION (17) FROM BETWEEN FRAME RAIL REINFORCEMENT (8) AND FRAME RAIL (9).

WARNING

Frame rail reinforcement weighs 100 lb (45.4 kg). Use minimum of three personnel to remove parts from frame rail reinforcement. Failure to do so could result in injury to personnel.

8. WITH TWO PERSONNEL HOLDING FRAME RAIL REINFORCEMENT (8), REMOVE TWO NUTS (4), TWO WASHERS (5), TWO CAPSCREWS (6), TWO WASHERS (7), AND FRAME RAIL REINFORCEMENT (8).

NOTE

In steps 9 and 10, note position of capscrews prior to removal to aid in installation.

9. REMOVE TWO NUTS (18), TWO WASHERS (19), TWO CAPSCREWS (20), TWO WASHERS (21), AND STIFFENER (22).

FRAME RAIL EXTENSION AND REINFORCEMENT REPLACEMENT (CONT)

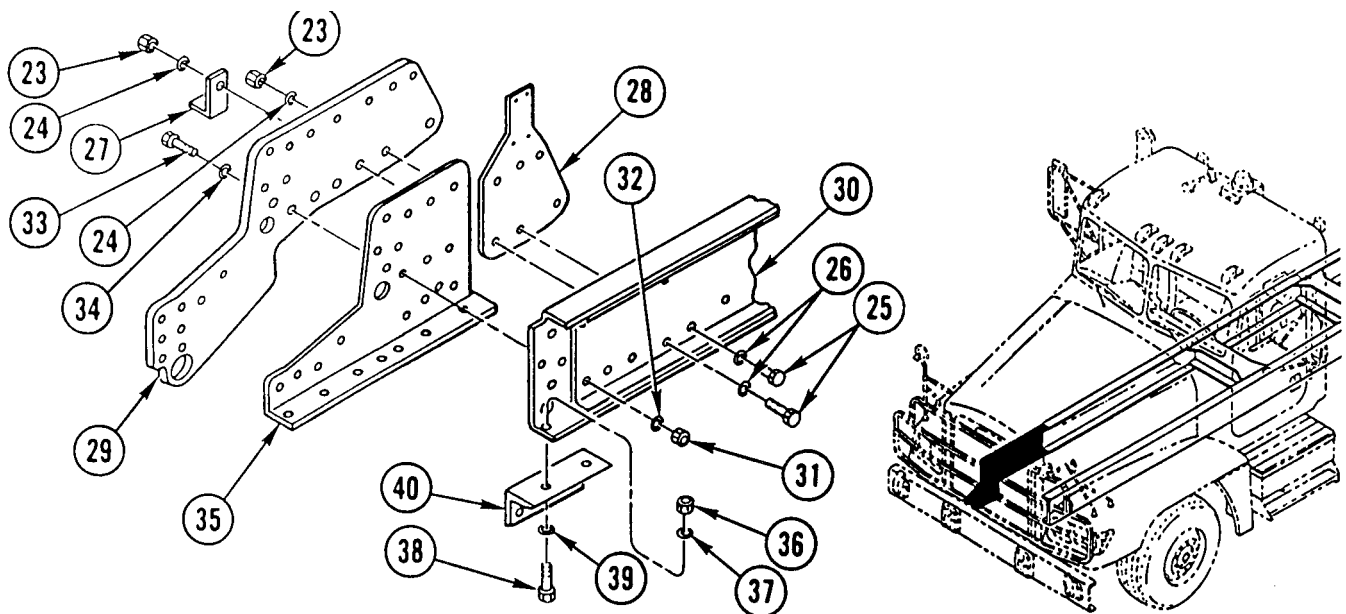

10. REMOVE FIVE NUTS (23), FIVE WASHERS (24), FIVE CAPSCREWS (25), FIVE WASHERS (26), AND BRACKET (27). SET BRACKET ASIDE.
11. REMOVE TRANSMISSION COOLER MOUNTING PLATE (28) FROM BETWEEN FRAME RAIL REINFORCEMENT (29) AND FRAME RAIL (30).
12. INSTALL ANY TWO WASHERS (26), TWO CAPSCREWS (25), TWO WASHERS (24), AND TWO NUTS (23) HAND-TIGHT IN FRAME RAIL REINFORCEMENT (29) AND FRAME RAIL (30).
13. REMOVE SIX NUTS (31), SIX WASHERS (32), SIX CAPSCREWS (33), AND SIX WASHERS (34),
14. REMOVE FRAME RAIL EXTENSION (35) FROM BETWEEN FRAME RAIL REINFORCEMENT (29) AND FRAME RAIL (30).
15. WITH TWO PERSONNEL HOLDING FRAME RAIL REINFORCEMENT (29), REMOVE TWO NUTS (23), TWO WASHERS (24), TWO CAPSCREWS (25), TWO WASHERS (26), AND FRAME RAIL REINFORCEMENT (29).

NOTE

Note position of cap screws prior to removal to aid in installation.

16. REMOVE TWO NUTS (36), TWO WASHERS (37), TWO CAPSCREWS (38), TWO WASHERS (39), AND STIFFENER (40).

Use general cleaning methods to clean all parts (page 2-30).

INSPECTION

Inspect all parts for wear or damage.

INSTALLATION

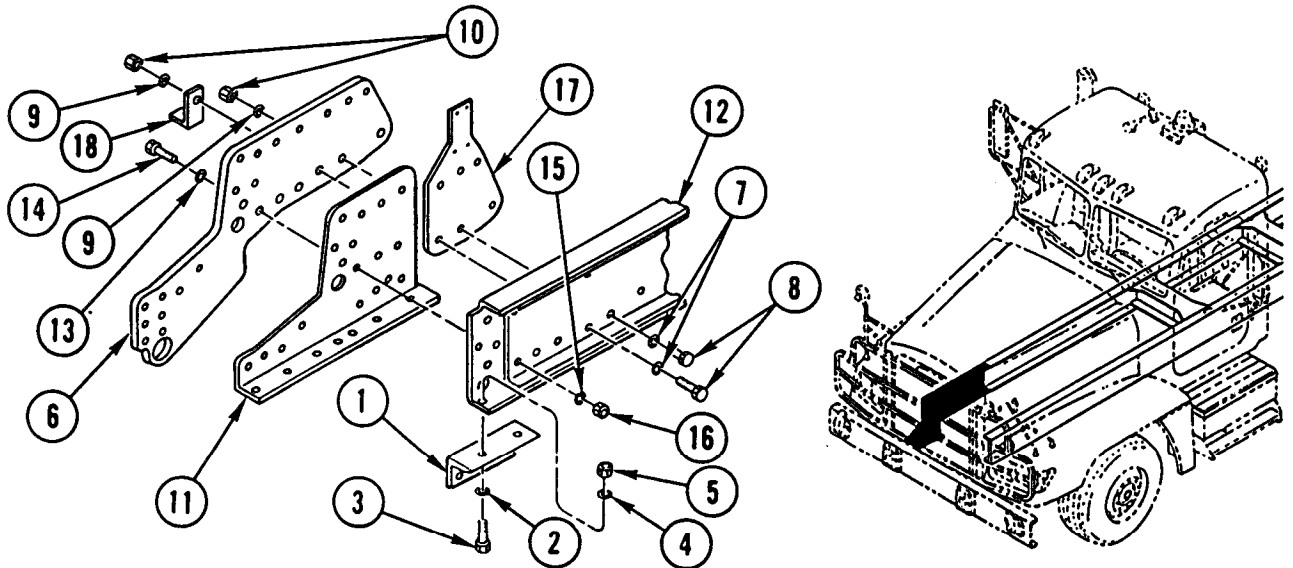

NOTE

Steps 1 thru 8 are for right side only.

Steps 9 thru 17 are for left side only.

1. INSTALL STIFFENER (1), TWO WASHERS (2), TWO CAPSCREWS (3), TWO WASHERS (4), AND TWO NUTS (5).

WARNING

Frame rail reinforcement weighs 100 lb (45.4 kg). Use minimum of three personnel to install parts on frame rail reinforcement. Failure to do so could result in injury to personnel.

2. WITH TWO PERSONNEL HOLDING FRAME RAIL REINFORCEMENT (6), INSTALL TWO WASHERS (7), TWO CAPSCREWS (8), TWO WASHERS (9), AND TWO NUTS (10) HAND-TIGHT.
3. INSTALL FRAME RAIL EXTENSION (11) BETWEEN FRAME RAIL (12) AND FRAME RAIL REINFORCEMENT (6).
4. INSTALL SIX WASHERS (13), SIX CAPSCREWS (14), SIX WASHERS (15), AND SIX NUTS (16). DO NOT TIGHTEN NUTS.
5. REMOVE TWO NUTS (10), TWO WASHERS (9), TWO CAPSCREWS (8), AND TWO WASHERS (7).
6. INSTALL TRANSMISSION COOLER MOUNTING PLATE (17) BETWEEN FRAME RAIL (12) AND FRAME RAIL REINFORCEMENT (6).
7. INSTALL BRACKET (18), FIVE WASHERS (7), FIVE CAPSCREWS (8), FIVE WASHERS (9), AND FIVE NUTS (10).
8. TIGHTEN NUTS (10 AND 16).

FRAME RAIL EXTENSION AND REINFORCEMENT REPLACEMENT (CONT)

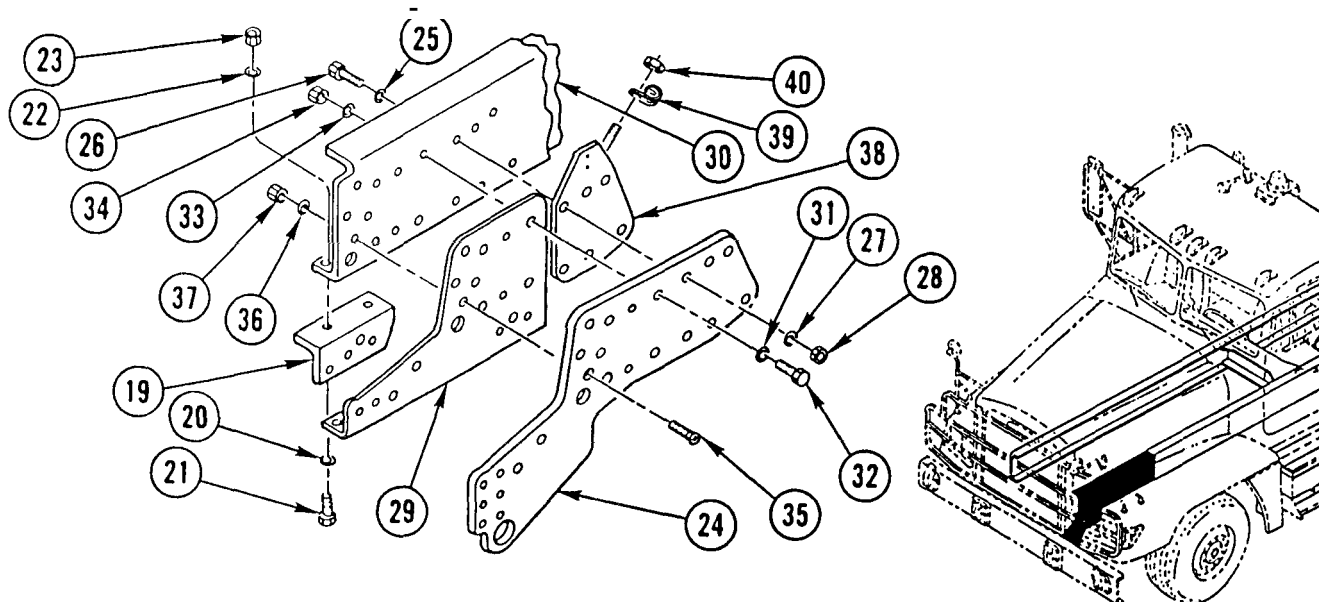

9. INSTALL STIFFENER (1 9), TWO WASHERS (20), TWO CAPSCREWS (21), TWO WASHERS (22), AND TWO NUTS (23).
10. WITH TWO PERSONNEL HOLDING FRAME RAIL REINFORCEMENT (24), INSTALL TWO WASHERS (25), TWO CAPSCREWS (26), TWO WASHERS (27), AND TWO NUTS (28) HAND-TIGHT.
11. INSTALL FRAME RAIL EXTENSION (29) BETWEEN FRAME RAIL (30) AND FRAME RAIL REINFORCEMENT (24).
12. INSTALL THREE WASHERS (31), THREE CAPSCREWS (32), THREE WASHERS (33), AND THREE NUTS (34). DO NOT TIGHTEN NUTS.
13. INSTALL TWO SCREWS (35), TWO WASHERS (36), AND TWO NUTS (37).
14. REMOVE TWO NUTS (28), TWO WASHERS (27), TWO CAPSCREWS (26), AND TWO WASHERS (25).
15. INSTALL POWER STEERING RESERVOIR PLATE (38) BETWEEN FRAME RAIL (30) AND FRAME RAIL REINFORCEMENT (24).
16. INSTALL SIX WASHERS (25), SIX CAPSCREWS (26), SIX WASHERS (27), AND SIX NUTS (28).
17. TIGHTEN NUTS (28 AND 34).
18. INSTALL CLAMP (39) AND NUT (40) ON POWER STEERING RESERVOIR PLATE (38).

NOTE

Follow-on Maintenance:

- Install power steering reservoir and hoses (TM 9-2320-363-20).
- Install water filter adapter and bracket (TM 9-2320-363-20).
- Install transmission oil cooler (TM 9-2320-363-20).
- Install front crossmember (page 8-10).
- Install front spring hangers (page 9-8).
- Install front engine mount support (page 8-7).

FRONT ENGINE MOUNT SUPPORT REPLACEMENT

This task covers: a. Removal b. Cleaning c. Inspection d. Installation

INITIAL SETUP

Tools and Special Equipment:

Tool Kit, SC 5180-90-CL-N05

Personnel Required: (2)

References:

TM 9-2320-363-20

Equipment Condition:

Reference

TM 9-2320-363-20

Page 8-10

Page 3-46

Condition Description

Front Quick-Release Valve Removed

Front Crossmember Removed

Front Engine Mount Adapter Removed

REMOVAL

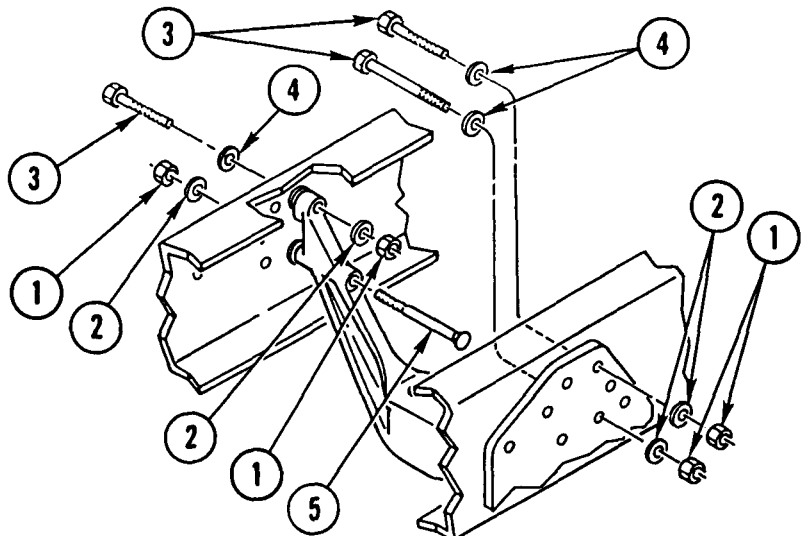
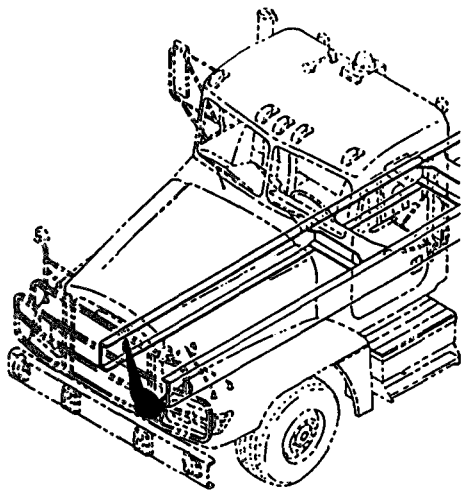

NOTE

Procedure is the same for both vehicles except as noted.

1. REMOVE FOUR NUTS (1), FOUR WASHERS (2), THREE CAPSCREWS (3), THREE WASHERS (4), AND SCREW (5).

FRONT ENGINE MOUNT SUPPORT REPLACEMENT (CONT)

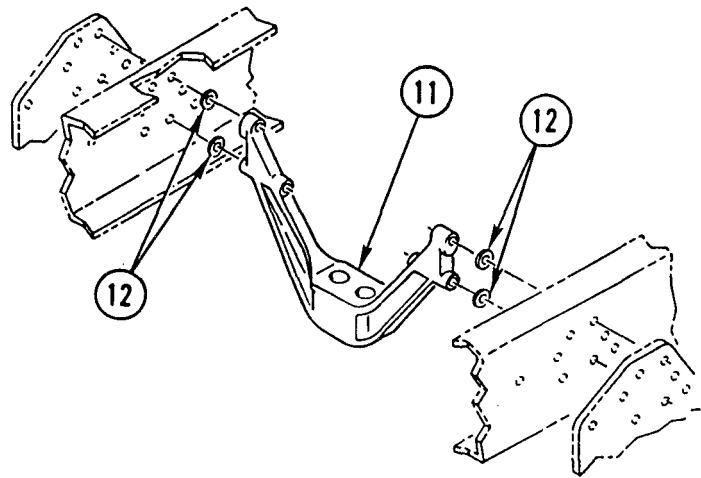
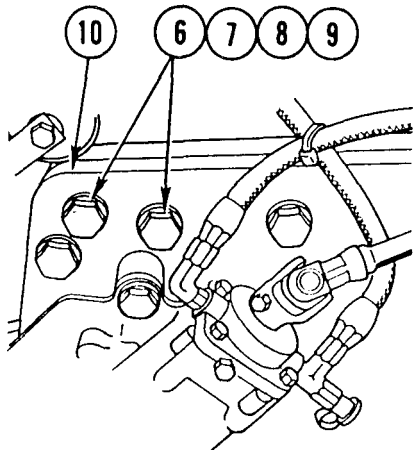

2. LEFT SIDE: REMOVE TWO NUTS (6), TWO WASHERS (7), TWO CAPSCREWS (8), AND TWO WASHERS (9) FROM FRAME (10).
3. REPEAT STEP 2 FOR RIGHT SIDE.
4. REMOVE FRONT ENGINE MOUNT SUPPORT (11).

NOTE

Step 5 is for M915A2 only.

5. REMOVE FOUR SPACERS (12).

CLEANING

Use general cleaning methods to clean all pads (page 2-30).

INSPECTION

Inspect all parts for wear or damage.

INSTALLATION

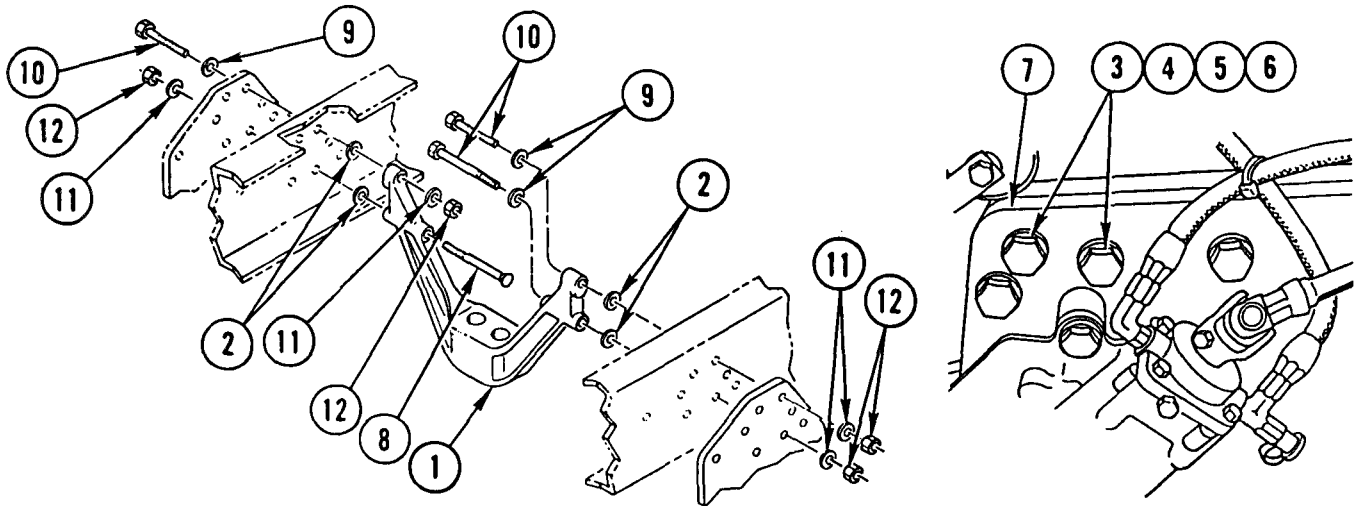

NOTE

Procedure is the same for both vehicles except as noted.

1. INSTALL FRONT ENGINE MOUNT SUPPORT (1).

NOTE

Step 2 is for M915A2 only.

2. INSTALL FOUR SPACERS (2).
3. LEFT SIDE: INSTALL TWO WASHERS (3), TWO CAPSCREWS (4), TWO WASHERS (5), AND TWO NUTS (6) ON FRAME (7).
4. REPEAT STEP 3 FOR RIGHT SIDE.

NOTE

M915A2 only: Make sure spacers installed during step 2 do not slip out of place. If spacer is not present, frame will not be in line to allow installation of front crossmember.

5. INSTALL SCREW (8), THREE WASHERS (9), THREE CAPSCREWS (10), FOUR WASHERS (11), AND FOUR NUTS (12).

NOTE

Follow-on Maintenance:
 Install front engine mount adapter (page 3-46).
 Install front crossmember (page 8-10).
 Install front quick-release valve (TM 9-2320-363-20).

FRONT CROSSMEMBER REPLACEMENT

This task covers: a. Removal b. Cleaning c. Inspection d. Installation

INITIAL SETUP

Tools and Special Equipment:

Tool Kit, SC 5180-90-CL-N05

Personnel Required: (2)

References:

TM 9-2320-363-20

Equipment Condition:

Reference	Condition Description
TM 9-2320-363-20	Radiator Removed
TM 9-2320-363-20	Front Bumper Removed
TM 9-2320-363-20	Hood Removed

REMOVAL

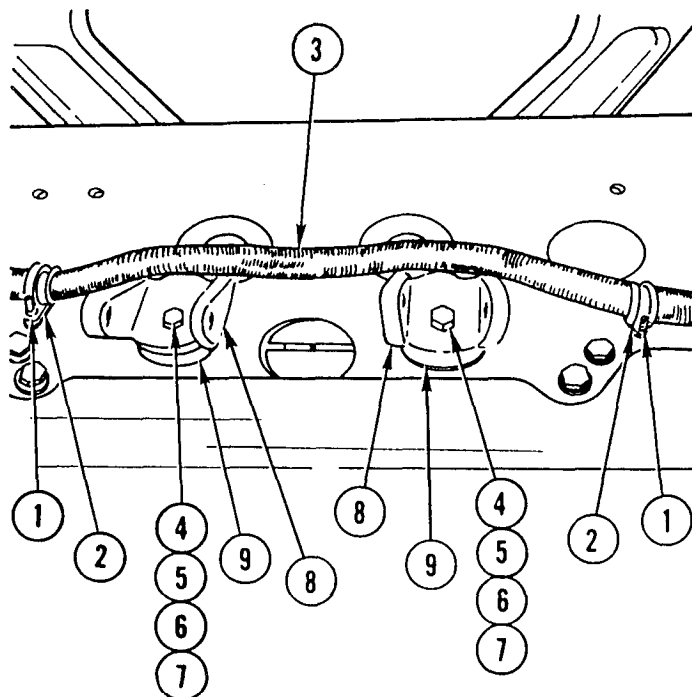

1. REMOVE TWO NUTS (1) AND TWO CLAMPS (2) AND SET WIRING HARNESS (3) ASIDE.
2. REMOVE TWO NUTS (4), TWO WASHERS (5), TWO CAPSCREWS (6), TWO WASHERS (7), TWO HINGE PIVOTS (8), AND TWO SPACERS (9).

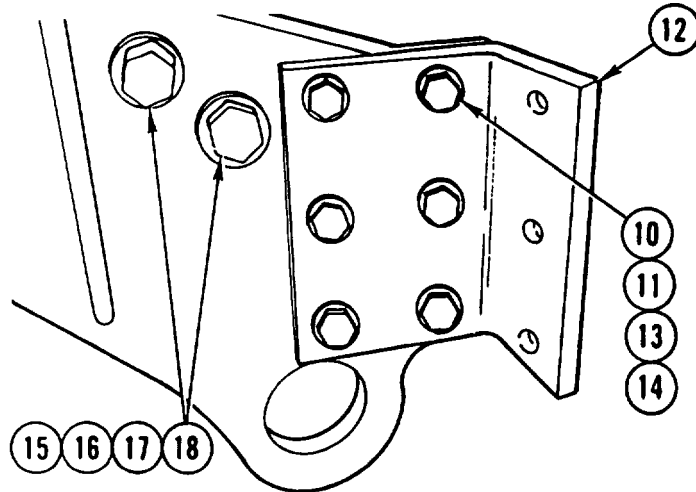

NOTE

Steps 3 thru 6 are for right side of vehicle.

3. REMOVE SIX NUTS (10), SIX WASHERS (11), BUMPER BRACKET (12), SIX CAPSCREWS (13), AND SIX WASHERS (14).
4. REMOVE TWO NUTS (15), TWO WASHERS (16), TWO CAPSCREWS (17), AND TWO WASHERS (18).

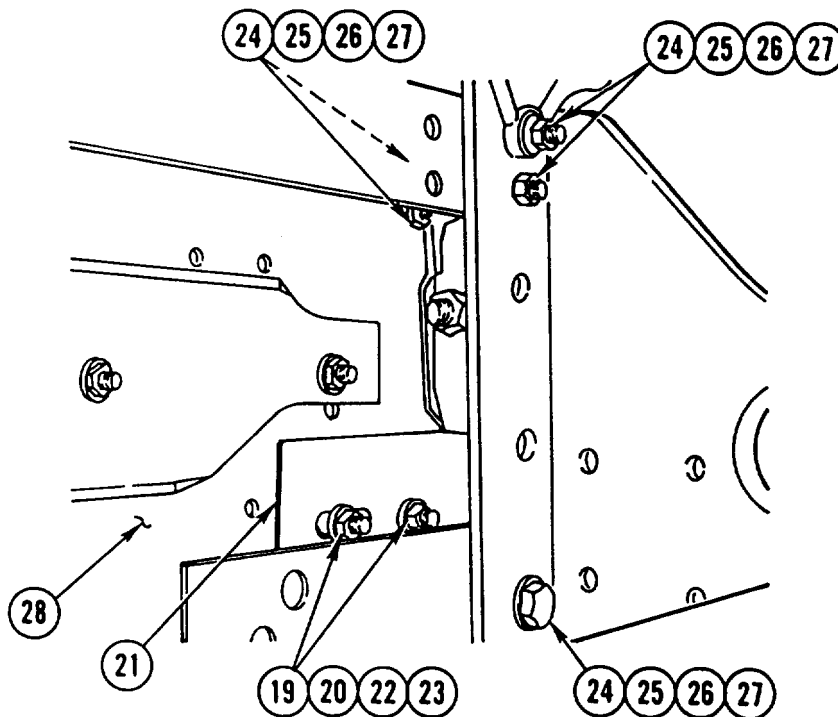

5. REMOVE TWO NUTS (19), TWO WASHERS (20), BRACKET (21), TWO CAPSCREWS (22), AND TWO WASHERS (23).
6. REMOVE FIVE NUTS (24), FIVE WASHERS (25), FIVE CAPSCREWS (26), AND FIVE WASHERS (27) FROM FRONT CROSSMEMBER (28).
7. REPEAT STEPS 3 THRU 6 FOR LEFT SIDE OF VEHICLE.
8. REMOVE FRONT CROSSMEMBER (28).

FRONT CROSSMEMBER REPLACEMENT (CONT)

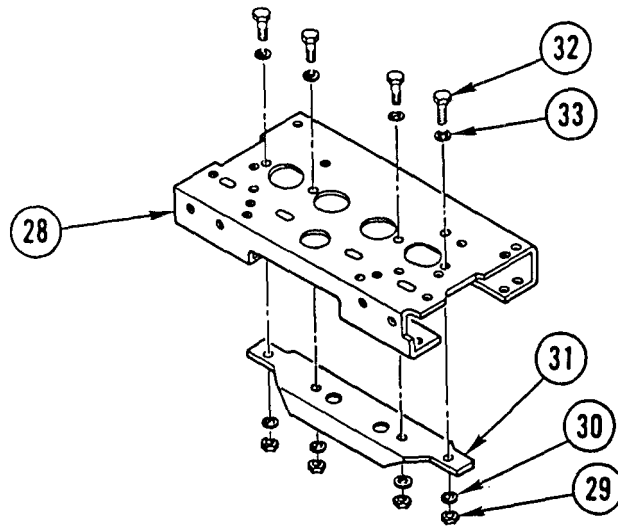

9. REMOVE FOUR NUTS (29), FOUR WASHERS (30), FRONT CROSSMEMBER REINFORCEMENT (31), FOUR CAPSCREWS (32), AND FOUR WASHERS (33) FROM FRONT CROSSMEMBER (28).

CLEANING

Use general cleaning methods to clean all parts (page 2-30).

INSPECTION

Inspect all part for wear or damage.

INSTALLATION

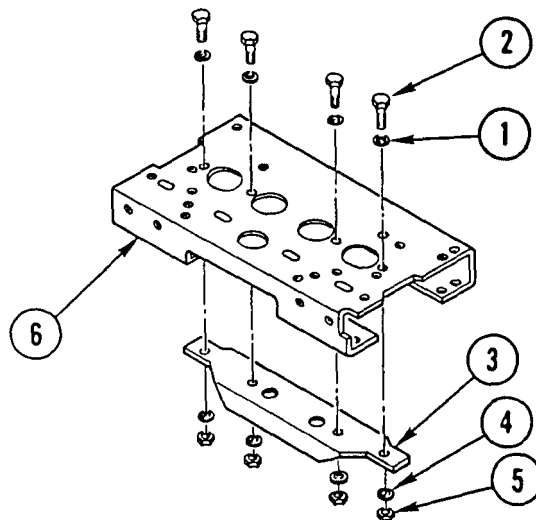

1. INSTALL FOUR WASHERS (1), FOUR CAPSCREWS (2), FRONT CROSSMEMBER REINFORCEMENT (3), FOUR WASHERS (4), AND FOUR NUTS (5) ON FRONT CROSSMEMBER (6).

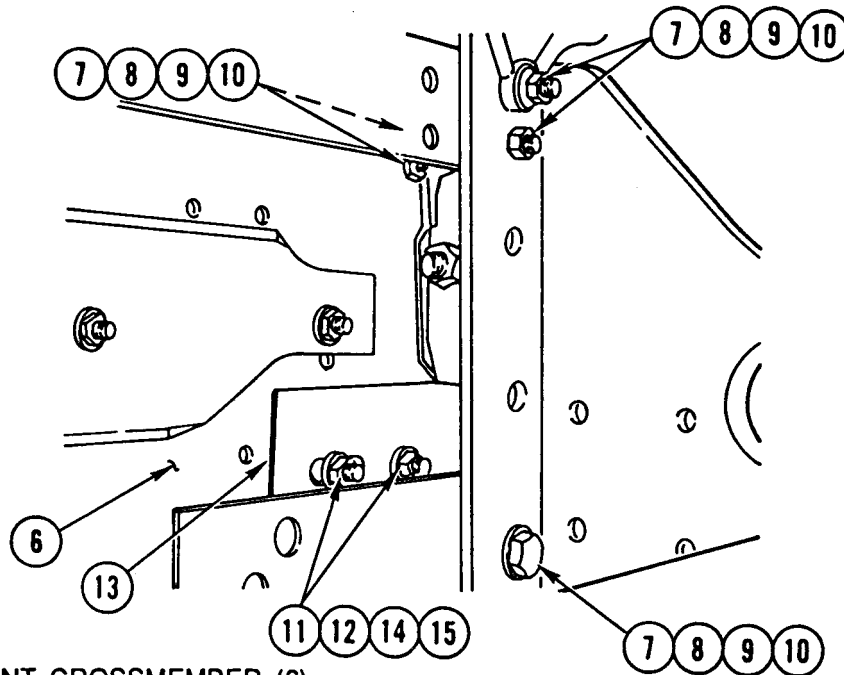

2. INSTALL FRONT CROSSMEMBER (6).

NOTE

Steps 3 thru 6 are for right side of vehicle.

3. INSTALL FIVE WASHERS (7), FIVE CAPSCREWS (8), FIVE WASHERS (9), AND FIVE NUTS (10) ON FRONT CROSSMEMBER (6).
4. INSTALL TWO WASHERS (11), TWO CAPSCREWS (12), BRACKET (13), TWO WASHERS (14), AND TWO NUTS (15).

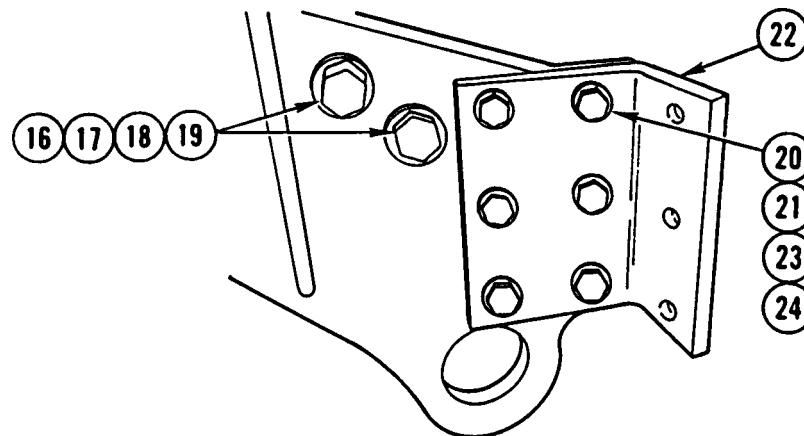

5. INSTALL TWO WASHERS (16), TWO CAPSCREWS (17), TWO WASHERS (18), AND TWO NUTS (19).
6. INSTALL SIX WASHERS (20), SIX CAPSCREWS (21), BUMPER BRACKET (22), SIX WASHERS (23), AND SIX NUTS (24).
7. REPEAT STEPS 3 THRU 6 FOR LEFT SIDE OF VEHICLE.

FRONT CROSSMEMBER REPLACEMENT (CONT)

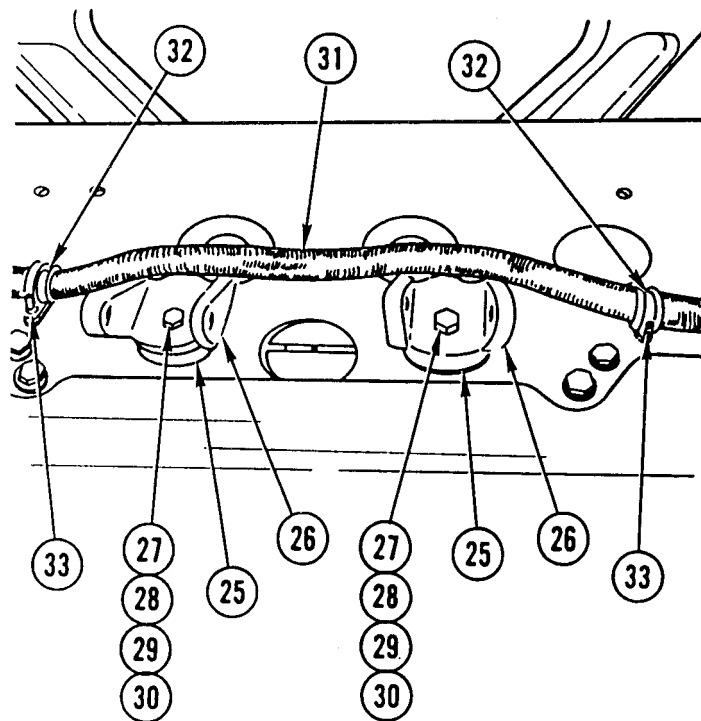

8. INSTALL TWO SPACERS (25), TWO HINGE PIVOTS (26), TWO WASHERS (27), TWO CAPSCREWS (28), TWO WASHERS (29), AND TWO NUTS (30).
9. MOVE WIRING HARNESS (31) INTO POSITION AND INSTALL TWO CLAMPS (32) AND TWO NUTS (33).

NOTE

Follow-on Maintenance:

- Install front bumper (TM 9-2320-363-20).
- Install radiator (TM 9-2320-363-20).
- Install hood (TM 9-2320-363-20).

REAR CROSSMEMBER ASSEMBLY REPLACEMENT

This task covers: a. Removal b. Cleaning c. Inspection d. Installation

INITIAL SETUP

Applicable Configuration:

M915A2

Tools and Special Equipment:

Shop Equipment, SC 491095-CL-A31
 Tool Kit, SC 5180-90-CL-N05

Materials/Parts:

Nut, Lock (4)

Personnel Required: (2)

References:

TM 9-2320-363-20

Equipment Condition:

Reference	Condition Description
TM 9-2320-363-20	Taillight Brackets Removed
TM 9-2320-363-20	Pintle Hook Removed

General Safety Instructions:

WARNING

- Plate weighs 96 lb (44 kg). Use hoist with lifting capacity of 200 lb (91 kg) to remove or install plate. Failure to do so could result in injury to personnel.
- Rear cross member weighs 460 lb (209 kg). Use hoist with lifting capacity of 600 lb (272 kg) to remove or install rear crossmember. Failure to do so could result in injury to personnel.

REAR CROSSMEMBER ASSEMBLY REPLACEMENT (CONT)

REMOVAL

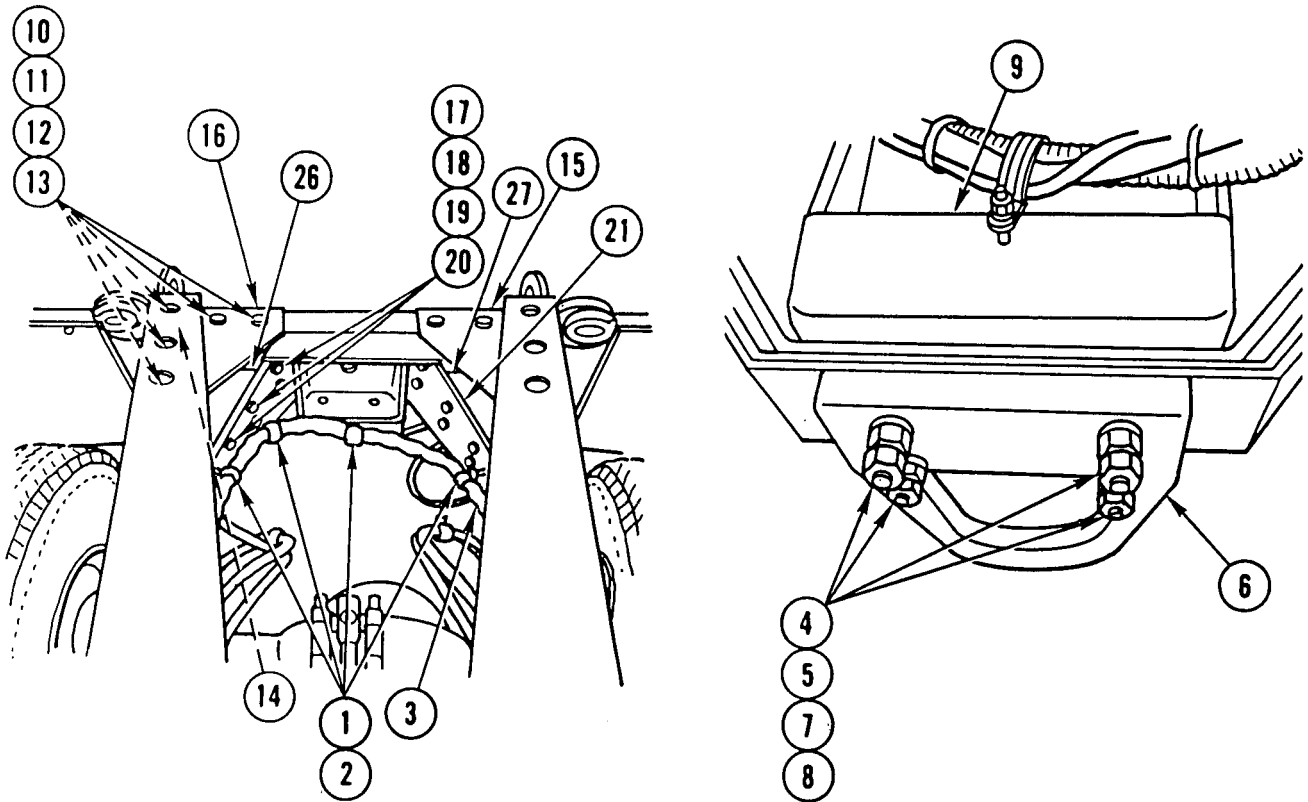

1. REMOVE FOUR LOCK NUTS (1) AND FOUR CLAMPS (2) AND SET WIRING HARNESS (3) ASIDE. DISCARD LOCK NUTS.
2. REMOVE EIGHT NUTS (4), FOUR WASHERS (5), TOWING BRACKET (6), FOUR SCREWS (7), FOUR WASHERS (8), AND REINFORCEMENT ASSEMBLY (9).
3. REMOVE FIVE NUTS (10), FIVE WASHERS (11), FIVE SCREWS (12), FIVE WASHERS (13), TWO SPACERS (14), AND LEFT SIDE GUSSET (15).
4. REPEAT STEP 3 FOR RIGHT SIDE GUSSET (16).

WARNING

Plate weighs 96 lb (44 kg). Use hoist with lifting capacity of 200 lb (91 kg) to remove plate. Failure to do so could result in injury to personnel.

5. ATTACH HOIST AND REMOVE 12 NUTS (17), 12 WASHERS (18), 12 SCREWS (19), 12 WASHERS (20), AND PLATE (21).

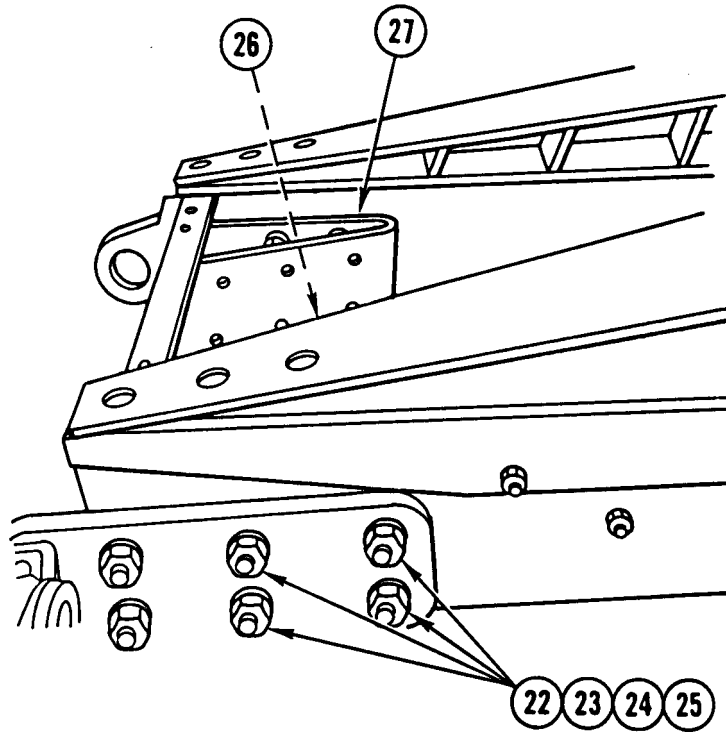

6. REMOVE FOUR NUTS (22), FOUR WASHERS (23), FOUR SCREWS (24), FOUR WASHERS (25), AND RIGHT SIDE SUPPORT (26).
7. REPEAT STEP 6 FOR LEFT SIDE SUPPORT (27).

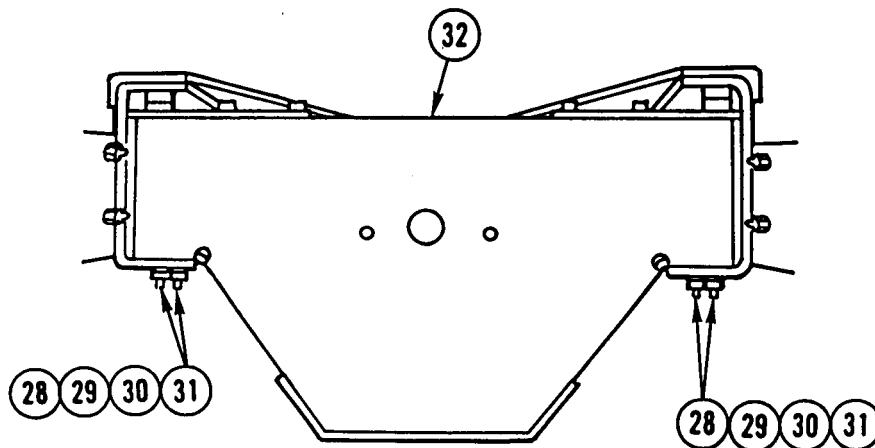

WARNING

Rear crossmember weighs 460 lb (209 kg). Use hoist with lifting capacity of 600 lb (272 kg) to remove rear crossmember. Failure to do so could result in injury to personnel.

8. ATTACH HOIST AND REMOVE FOUR NUTS (28), FOUR WASHERS (29), FOUR SCREWS (30), FOUR WASHERS (31), AND REAR CROSSMEMBER (32).

REAR CROSSMEMBER ASSEMBLY REPLACEMENT (CONT)

CLEANING

Use general cleaning methods to clean all parts (page 2-30).

INSPECTION

Inspect all parts for wear or damage.

INSTALLATION

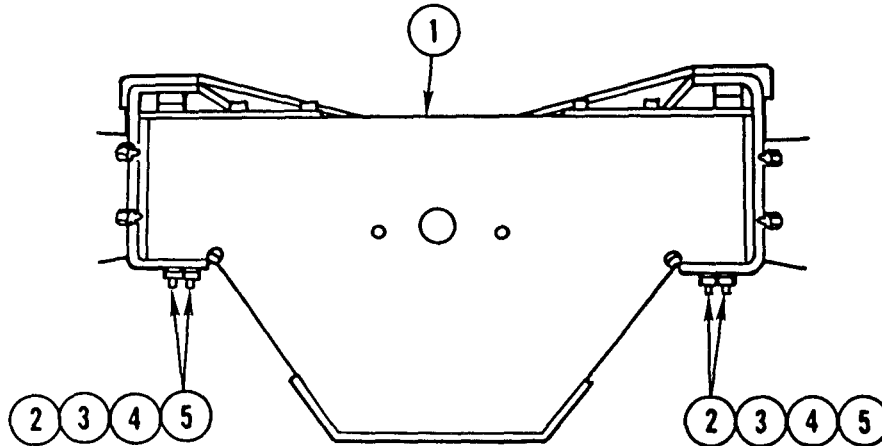

WARNING

Rear crossmember weighs 460 lb (209 kg), Use hoist with lifting capacity of 600 lb (272 kg) to install rear crossmember. Failure to do so could result in injury to personnel.

1. INSTALL REAR CROSSMEMBER (1), FOUR WASHERS (2), FOUR SCREWS (3), FOUR WASHERS (4), AND FOUR NUTS (5).

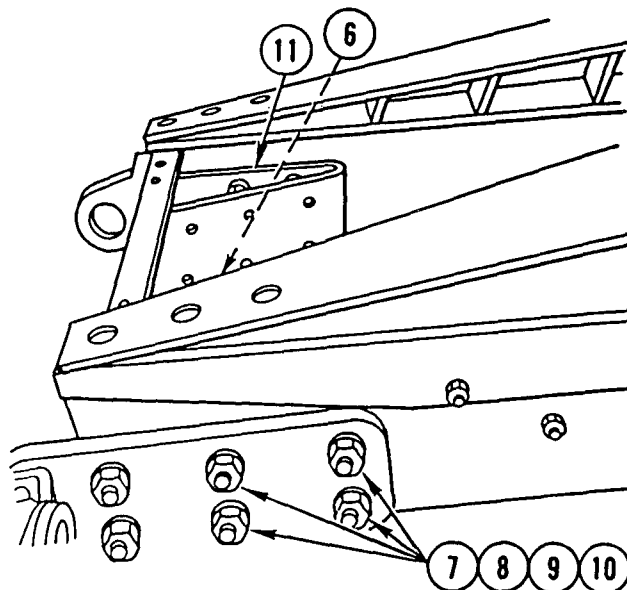

2. INSTALL RIGHT SIDE SUPPORT (6), FOUR WASHERS (7), FOUR SCREWS (8), FOUR WASHERS (9), AND FOUR NUTS (10).
3. REPEAT STEP 2 FOR LEFT SIDE SUPPORT (11)

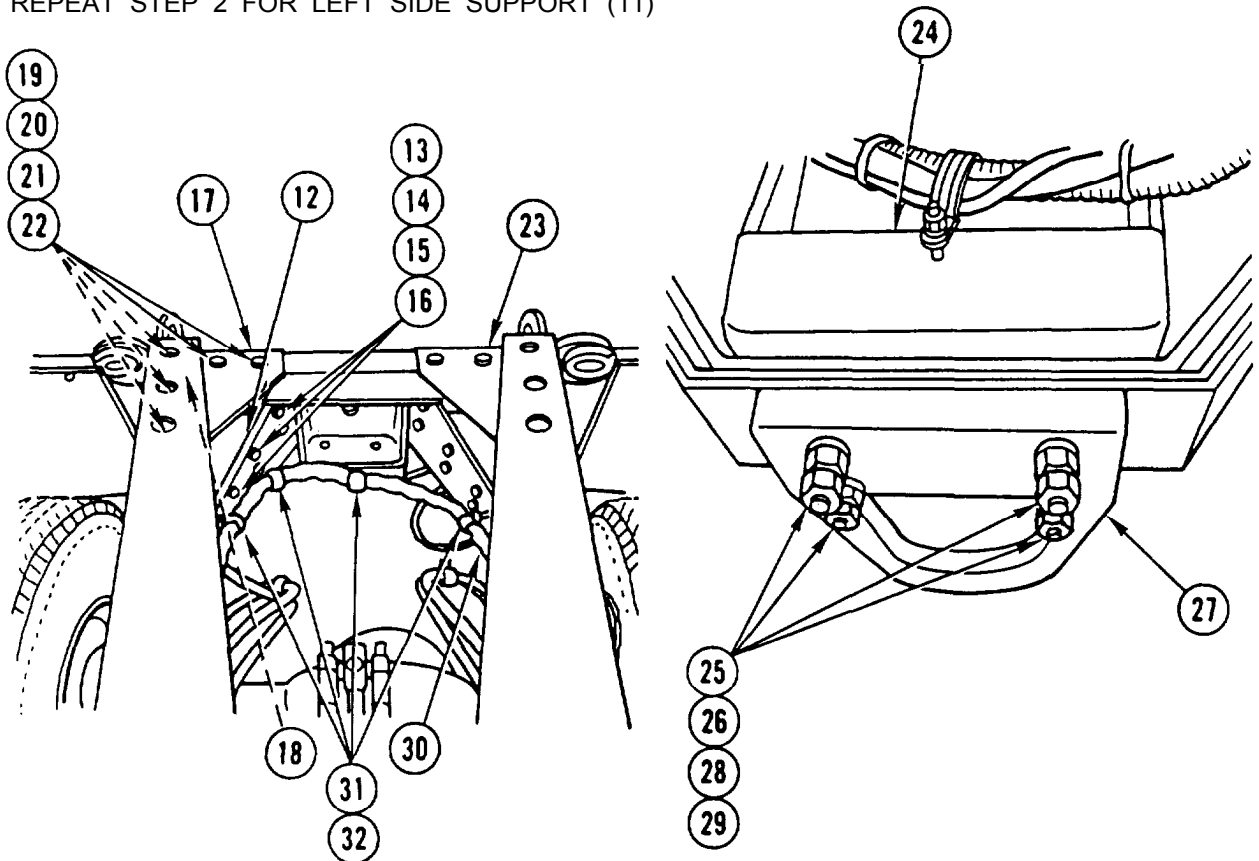

WARNING

Plate weighs 96 lb (44 kg). Use hoist with lifting capacity of 200 lb (91 kg) to install plate. Failure to do so could result in injury to personnel.

4. ATTACH HOIST AND INSTALL PLATE (12), 12 WASHERS (13), 12 SCREWS (14), 12 WASHERS (15), AND 12 NUTS (16).
5. INSTALL RIGHT SIDE GUSSET (17), TWO SPACERS (18), FIVE WASHERS (19), FIVE SCREWS (20), FIVE WASHERS (21), AND FIVE NUTS (22).
6. REPEAT STEP 5 FOR LEFT SIDE GUSSET (23).
7. INSTALL REINFORCEMENT ASSEMBLY (24), FOUR WASHERS (25), FOUR SCREWS (26), TOWING BRACKET (27), FOUR WASHERS (28), AND EIGHT NUTS (29).
8. MOVE WIRING HARNESS (30) INTO POSITION AND INSTALL FOUR CLAMPS (31) AND FOUR NEW LOCK NUTS (32).

NOTE

Follow-on Maintenance:

- Install pintle hook (TM 9-2320-363-20).
- Install taillight brackets (TM 9-2320-363-20).

REAR CROSSMEMBER ASSEMBLY REPLACEMENT

This task covers: a. Removal b. Cleaning c. Inspection d. Installation

INITIAL SETUP

Applicable Configuration:

All except M915A2

Tools and Special Equipment:

Shop Equipment, SC 4910-95-CL-A31
 Tool Kit, SC 5180-90-CL-N05

Materials/Parts:

Nut, Lock (37) (M916A1 and M916A2)

Nut, Lock (43) (M917A1 and M917A1 w/MCS)

Personnel Required: (2)

References:

TM 9-2320-363-20

Equipment Condition:

Reference	Condition Description
TM 9-2320-363-20	Taillight Brackets Removed

Equipment Condition (Cont):

Reference	Condition Description
TM 9-2320-363-20	Pintle Hook Removed
TM 9-2320-363-20	Grate Removed (M916A1 and M916A2)
TM 9-2320-363-20	Rear Tiedown and Roller Removed (M916A1 and M916A2)
TM 9-2320-363-20	Rear Tiedown Removed (M917A1 and M917A1 w/MCS)

General Safety Instructions:

WARNING

Rear crossmember weighs 460 lb (209 kg). Use hoist with lifting capacity of 600 lb (272 kg) to remove or install rear crossmember. Failure to do so could result in injury to personnel.

REMOVAL

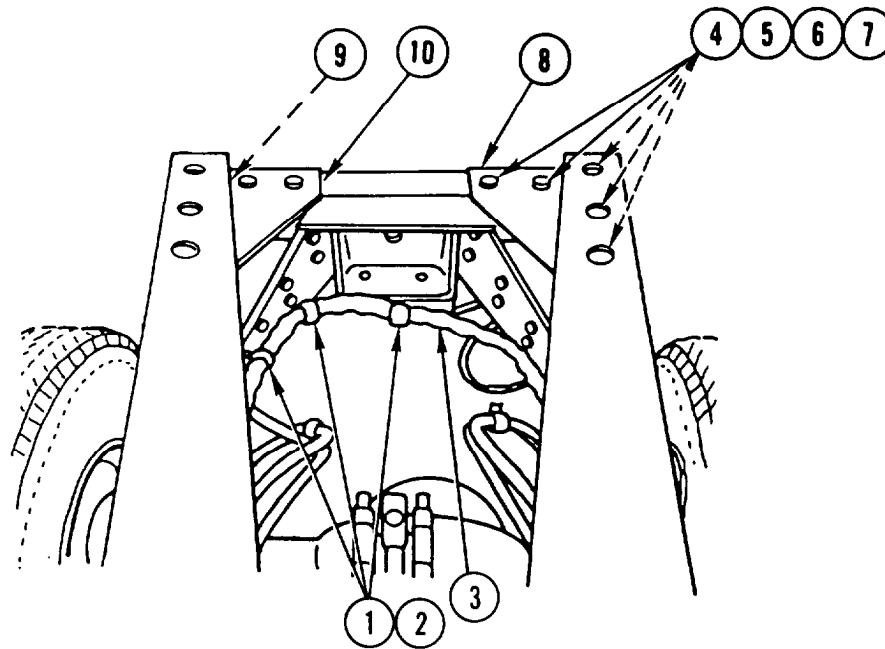

1. REMOVE THREE LOCK NUTS (1) AND THREE CLAMPS (2) AND MOVE WIRE/HOSE HARNESS (3) ASIDE. DISCARD LOCK NUTS.
2. REMOVE FIVE LOCK NUTS (4), FIVE WASHERS (5), FIVE SCREWS (6), FIVE WASHERS (7), LEFT SIDE GUSSET (8), AND SPACER (9). DISCARD LOCK NUTS.
3. REPEAT STEP 2 FOR RIGHT SIDE GUSSET (10).

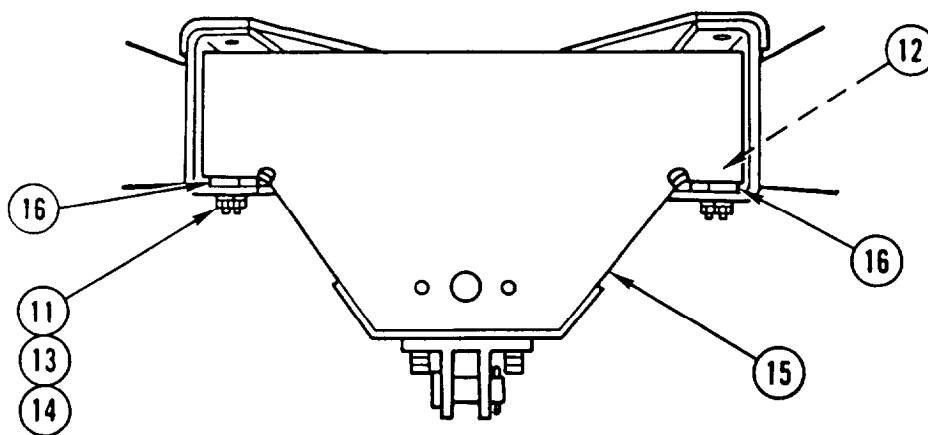

CAUTION

Rear crossmember weighs 460 lb (209 kg). Use hoist with lifting capacity of 600 lb (209 kg) to remove rear crossmember. Failure to do so could result in injury to personnel.

4. ATTACH HOIST AND REMOVE FOUR LOCK NUTS (11), FOUR WASHERS (12), FOUR SCREWS (13), FOUR WASHERS (14), REAR CROSSMEMBER (15), AND TWO SPACERS (16). DISCARD LOCK NUTS

REAR CROSSMEMBER ASSEMBLY REPLACEMENT (CONT)

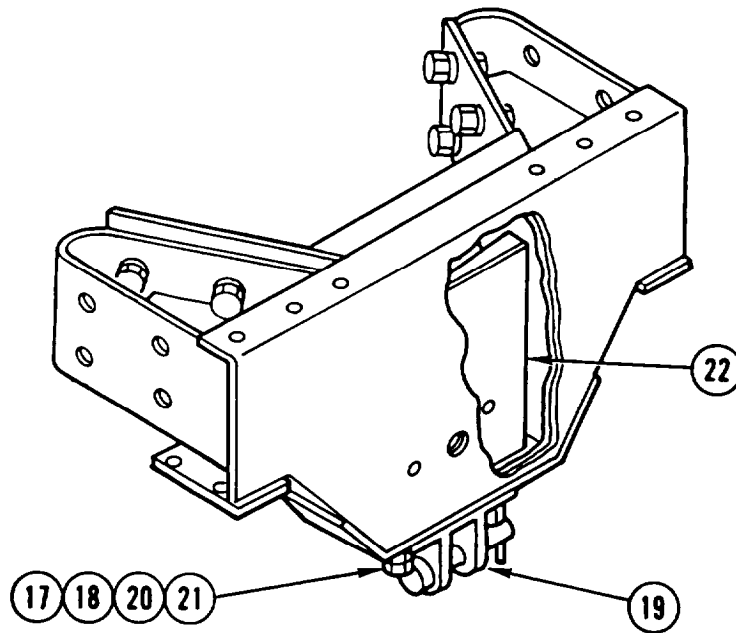

5. REMOVE EIGHT LOCK NUTS (17), FOUR WASHERS (18), TOWING BRACKET (19), FOUR SCREWS (20), FOUR WASHERS (21), AND REINFORCEMENT ASSEMBLY (22). DISCARD LOCK NUTS.

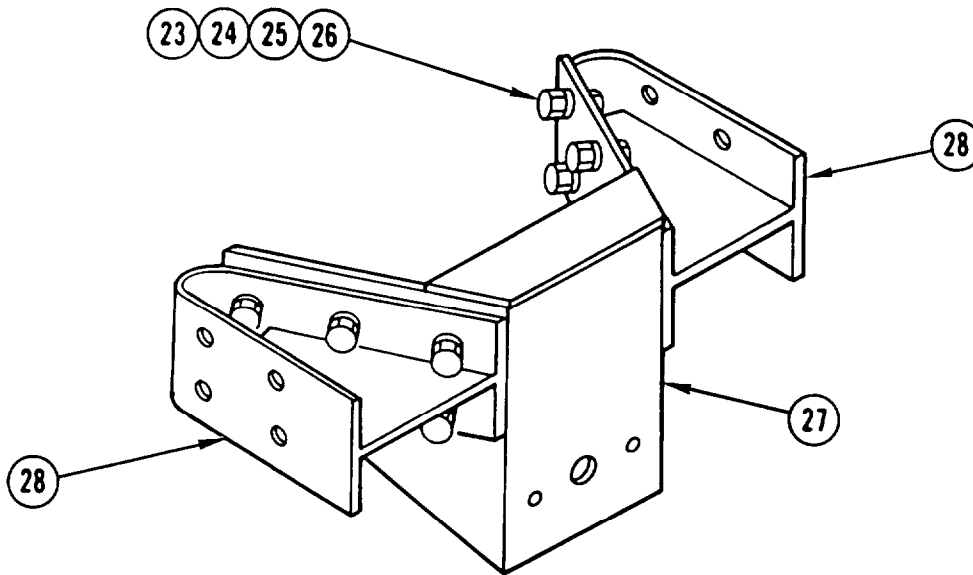

6. REMOVE 12 LOCK NUTS (23), 12 WASHERS (24), 12 SCREWS (25), 12 WASHERS (26), PLATE (27), AND SIDE PLATE (28). DISCARD LOCK NUTS.

CLEANING

Use general cleaning methods to clean all parts (page 2-30).

INSPECTION

Inspect all parts for wear or damage.

INSTALLATION

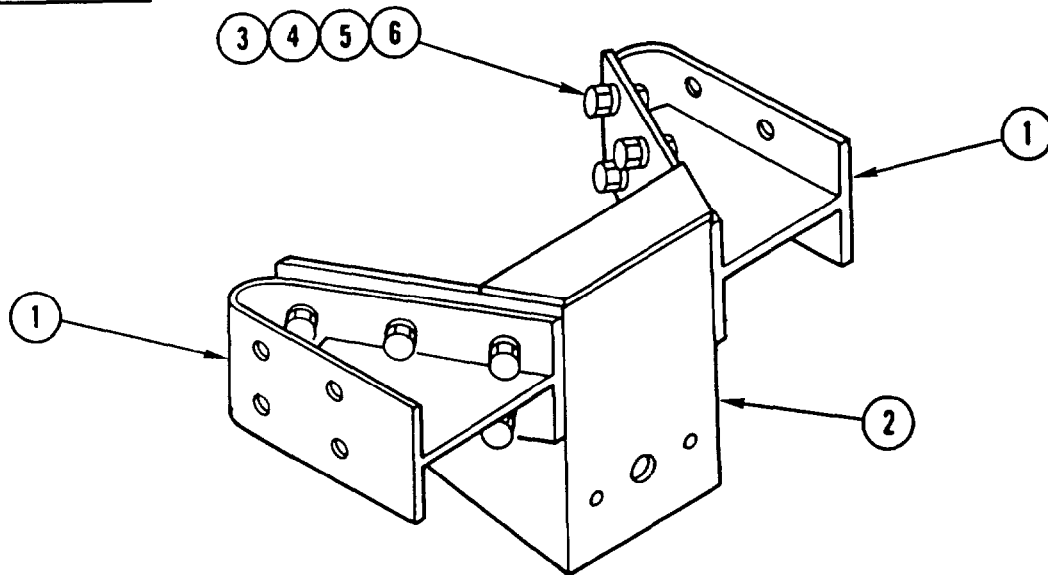

1. INSTALL SIDE PLATE (1), PLATE (2), 12 WASHERS (3), 12 SCREWS (4), 12 WASHERS (5), AND 12 NEW LOCK NUTS (6).

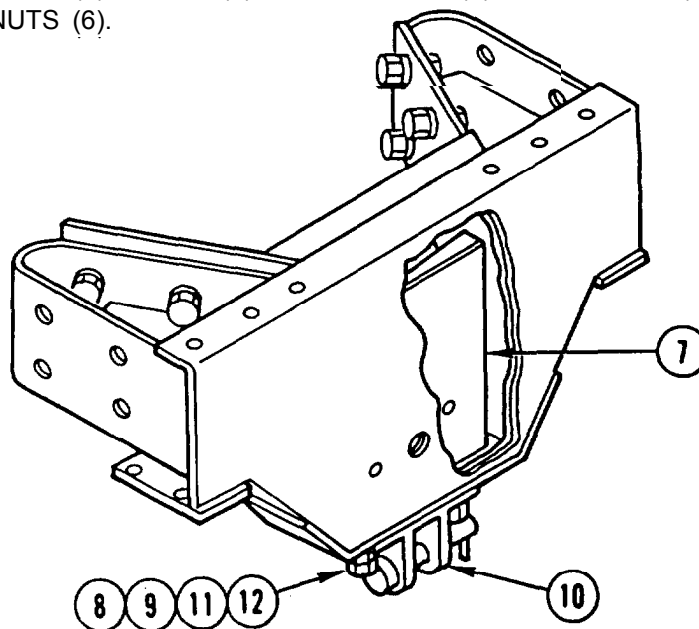

2. INSTALL REINFORCEMENT ASSEMBLY (7), FOUR WASHERS (8), FOUR SCREWS (9), TOWING BRACKET (10), FOUR WASHERS (11), AND EIGHT NEW LOCK NUTS (12).

REAR CROSSMEMBER ASSEMBLY REPLACEMENT (CONT)

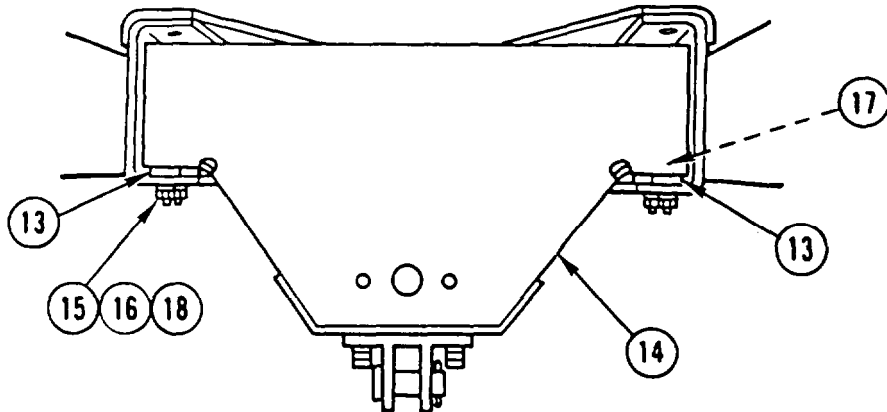

WARNING
 Rear crossmember weighs 460 lb (209 kg). Use hoist with lifting capacity of 600 (272 kg) to install rear crossmember. Failure to do so could result in injury to personnel.

3. ATTACH HOIST AND INSTALL TWO SPACERS (13), REAR CROSSMEMBER (14), FOUR WASHERS (15), FOUR SCREWS (16), FOUR WASHERS (17), AND FOUR NEW LOCK NUTS (18).

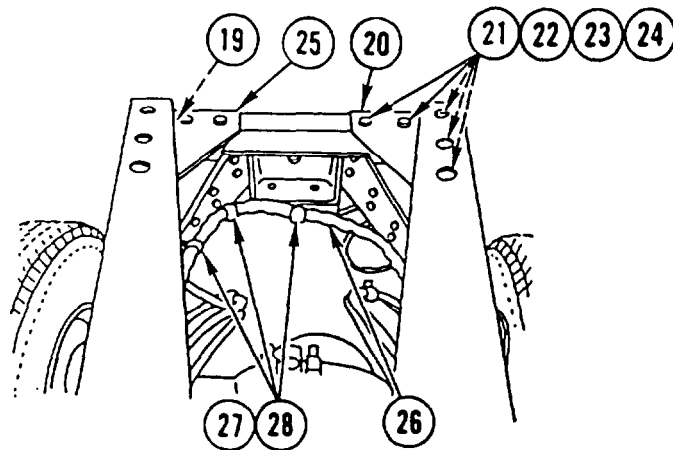

4. INSTALL SPACER (19), LEFT SIDE GUSSET (20), FIVE WASHERS (21), FIVE SCREWS (22), FIVE WASHERS (23), AND FIVE NEW LOCK NUTS (24).
5. REPEAT STEP 4 FOR RIGHT SIDE GUSSET (25).
6. MOVE WIRE/HOSE HARNESS (26) INTO POSITION AND INSTALL THREE CLAMPS (27) AND THREE NEW LOCK NUTS (28).

NOTE
 Follow-on Maintenance:
 Install rear tiedown (TM 9-2320-363-20)(M917A1 and M917A1 w/MCS).
 Install rear tiedown and roller (TM 9-2320-363-20) (M916A1 and M916A2).
 Install grate (TM 9-2320-363-20)(M916A1 and M916A2).
 Install pintle hook (TM 9-2320-363-20).
 Install taillight brackets (TM 9-2320-363-20).

OVERSLUNG CROSSMEMBER REPLACEMENT

This task covers: a. Removal b. Cleaning c. Inspection d. Installation

INITIAL SETUP

Tools and Special Equipment:

Tool Kit, SC 5180-90-CL-N05

References:

TM 9-2320-363-20

Equipment Condition:

Reference

TM 9-2320-363-20

TM 9-2320-363-20

Condition Description

Fender Extensions
Removed

Transmission Tunnel
Access Cover Removed

REMOVAL

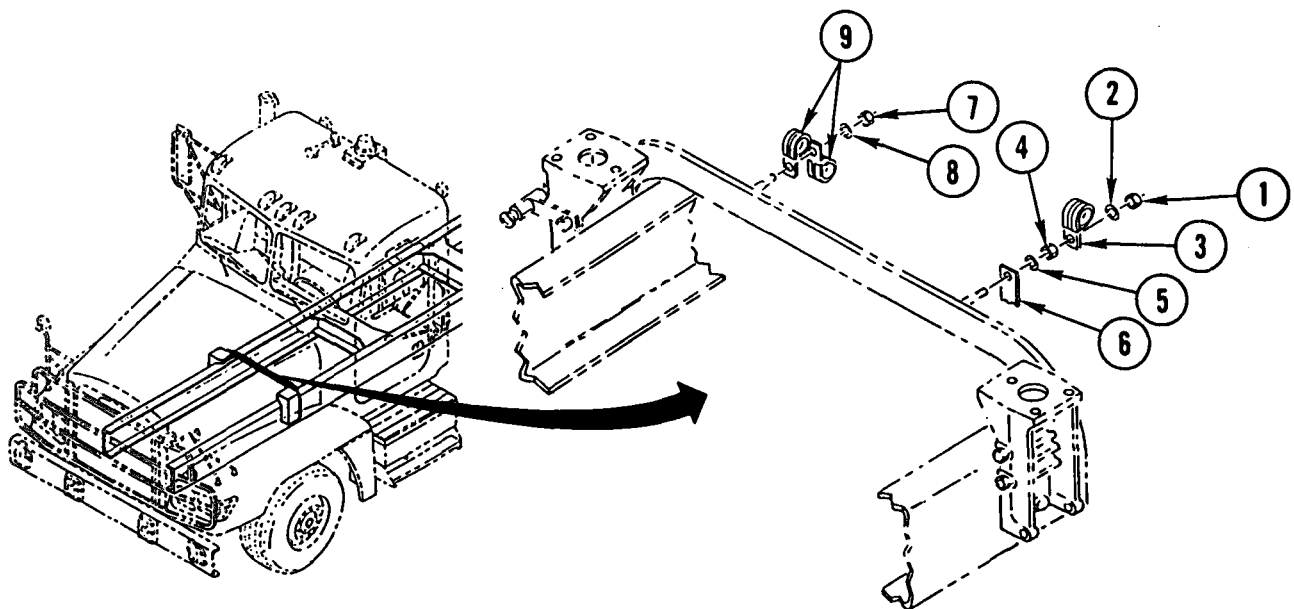

NOTE

Step 1 is for left side only.

1. REMOVE NUT (1), WASHER (2), CLAMP (3), NUT (4), WASHER (5), AND BRACKET (6).

NOTE

Step 2 is for right side only.

2. REMOVE NUT (7), WASHER (8), AND TWO CLAMPS (9).

OVERSLUNG CROSSMEMBER REPLACEMENT (CONT)

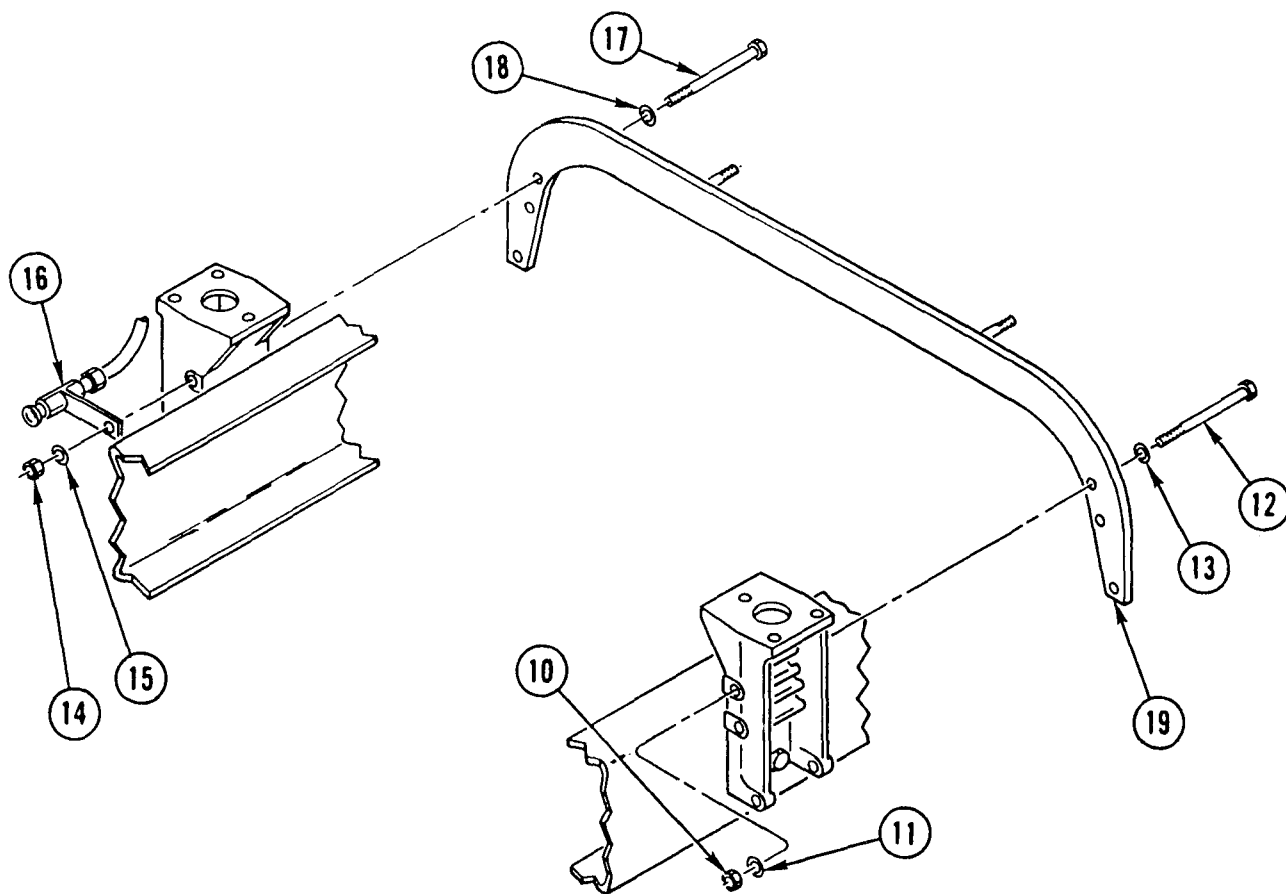

3. REMOVE NUT (10), WASHER (11), CAPSCREW (12), AND WASHER (13).
4. REMOVE NUT (14) AND WASHER (15) AND SET AOAP VALVE (16) ASIDE.
5. REMOVE CAPSCREW (17), WASHER (18), AND OVERSLUNG CROSSMEMBER (19).

CLEANING

Use general cleaning methods to clean all parts (page 2-30).

INSPECTION

Inspect all parts for wear or damage.

INSTALLATION

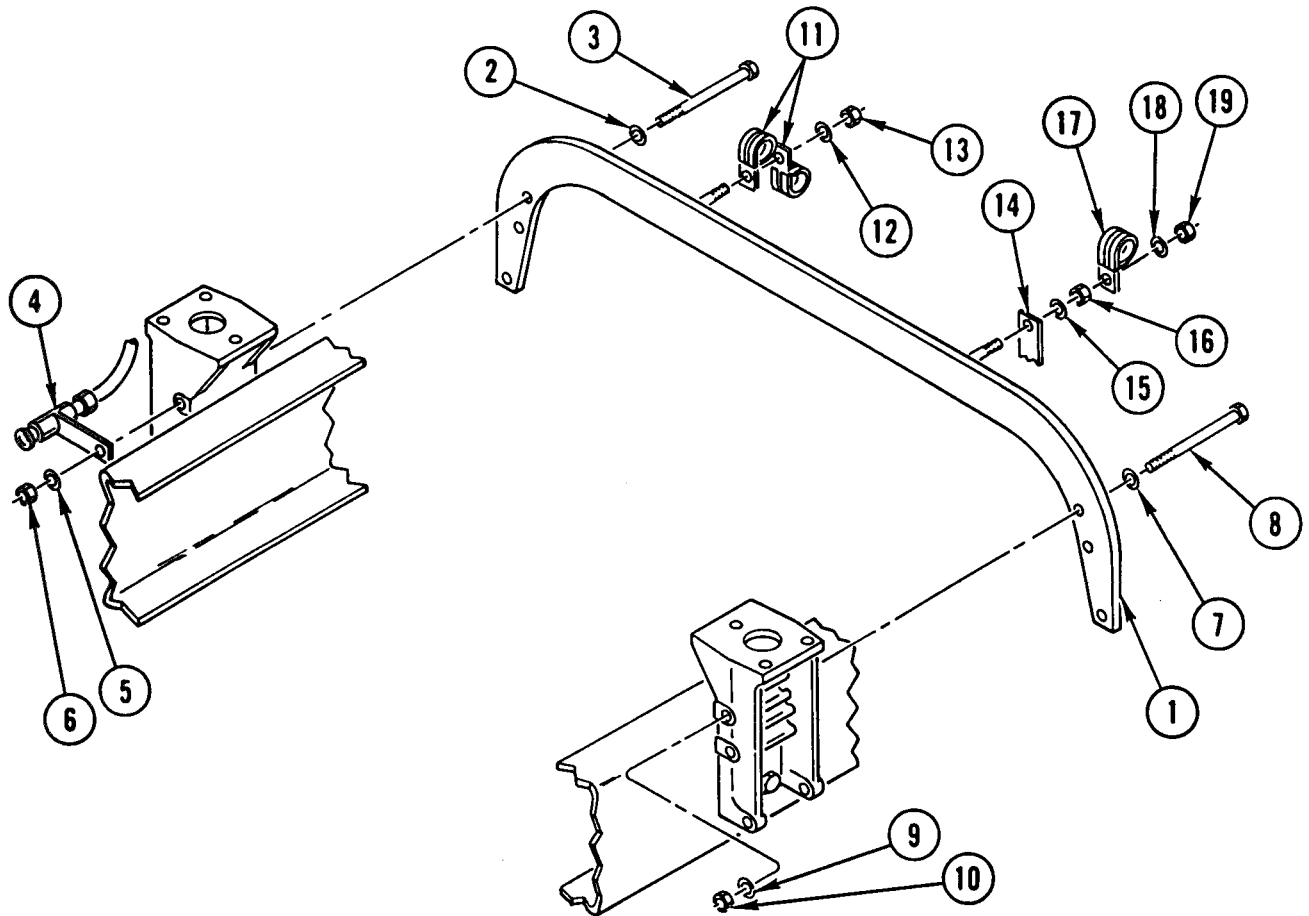

1. INSTALL OVERSLUNG CROSSMEMBER (1), WASHER (2), AND CAPSCREW (3).
2. INSTALL AOAP VALVE (4), WASHER (5), AND NUT (6).
3. INSTALL WASHER (7), CAPSCREW (8), WASHER (9), AND NUT (10).

NOTE

Step 4 is for right side only.

4. INSTALL TWO CLAMPS (11), WASHER (12), AND NUT (13).

NOTE

Step 5 is for left side only.

5. INSTALL BRACKET (14), WASHER (15), NUT (16), CLAMP (17), WASHER (18), AND NUT (19).

NOTE

Follow-on Maintenance:
 Install fender extensions (TM 9-2320-363-20).
 Install transmission tunnel access cover (TM 9-2320-363-20).

CAB ALLIGATOR CROSSMEMBER REPLACEMENT

This task covers: a. Removal b. Cleaning c. Inspection d. Installation

INITIAL SETUP

Applicable Configuration:

M915A2

Tools and Special Equipment:

Shop Equipment, SC 4910-95-CL-A31
 Tool Kit, SC 5180-90-CL-N05

Personnel Required: (3)

References:

TM 9-2320-363-20

Equipment Condition:

Reference

Condition Description

TM 9-2320-363-20

Spare Wheel Hoist
 Removed

TM 9-2320-363-20

Left Side Platform
 Removed

TM 9-2320-363-20

Personal Gear Storage
 Box and Mounting
 Bracket Removed

Equipment Condition (Cont):

Reference

Condition Description

TM 9-2320-363-20

Air Dryer Removed

TM 9-2320-363-20

Rear Platform Removed

TM 9-2320-363-20

Forward Driveline
 Removed

Page 20-3

Fifth Wheel Removed

Page 8-25

Overslung Crossmember
 Removed

Page 10-49

Rear Cab Mounts
 Removed

Page 8-15

Rear Crossmember
 Removed

REMOVAL

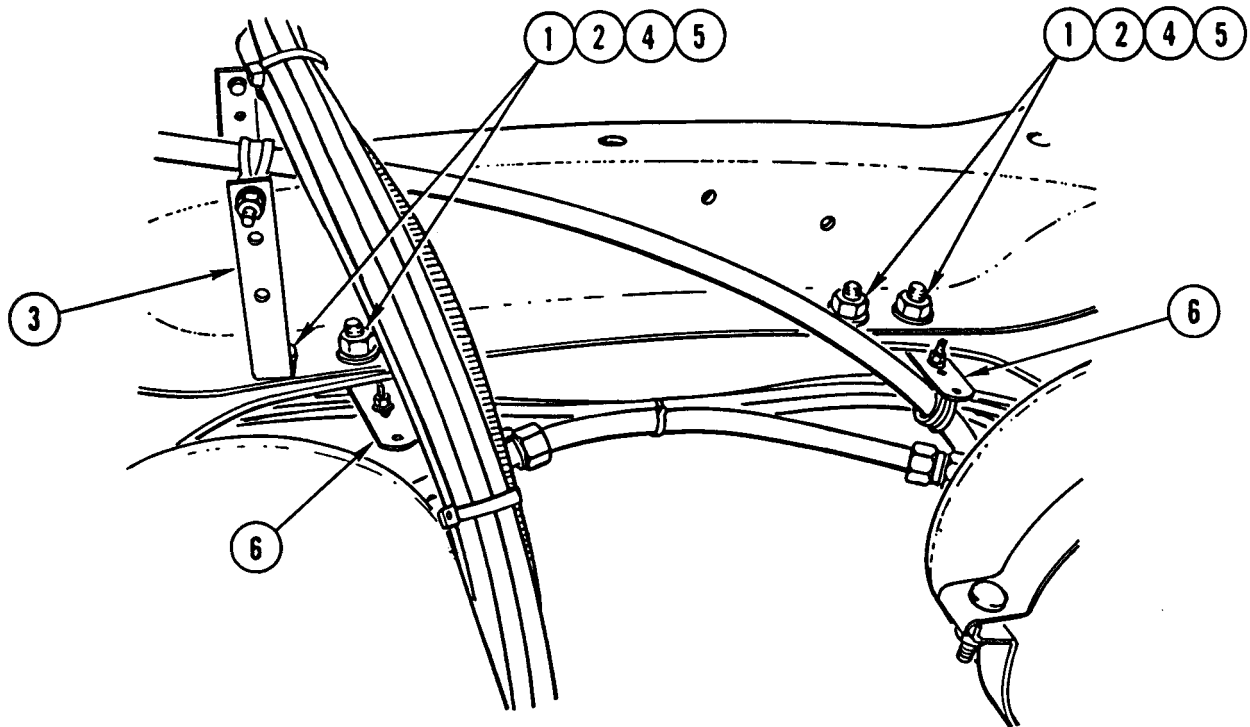

NOTE

Following procedure is done on right side of vehicle.

1. REMOVE FOUR NUTS (1), FOUR WASHERS (2), BRACKET (3), FOUR CAPSCREWS (4), FOUR WASHERS (5), AND TWO BRACKETS (6). SET BRACKETS (3 AND 6) ASIDE.

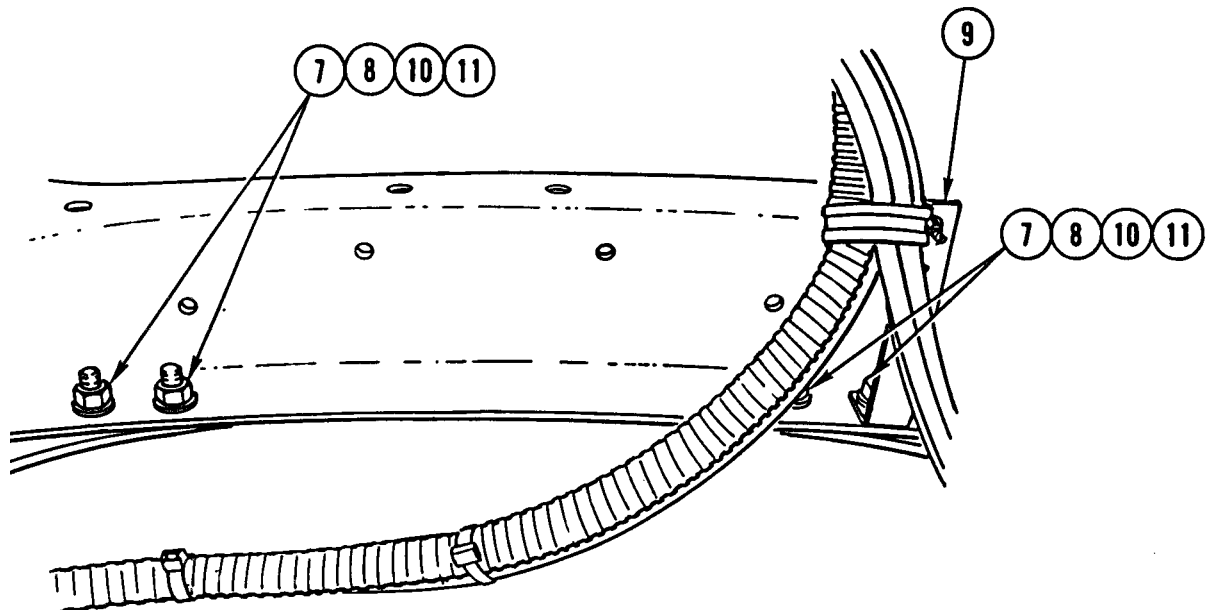

2. REMOVE FOUR NUTS (7), FOUR WASHERS (8), BRACKET (9), FOUR CAPSCREWS (10), AND FOUR WASHERS (11). SET BRACKET ASIDE.

CAB ALLIGATOR CROSSMEMBER REPLACEMENT (CONT)

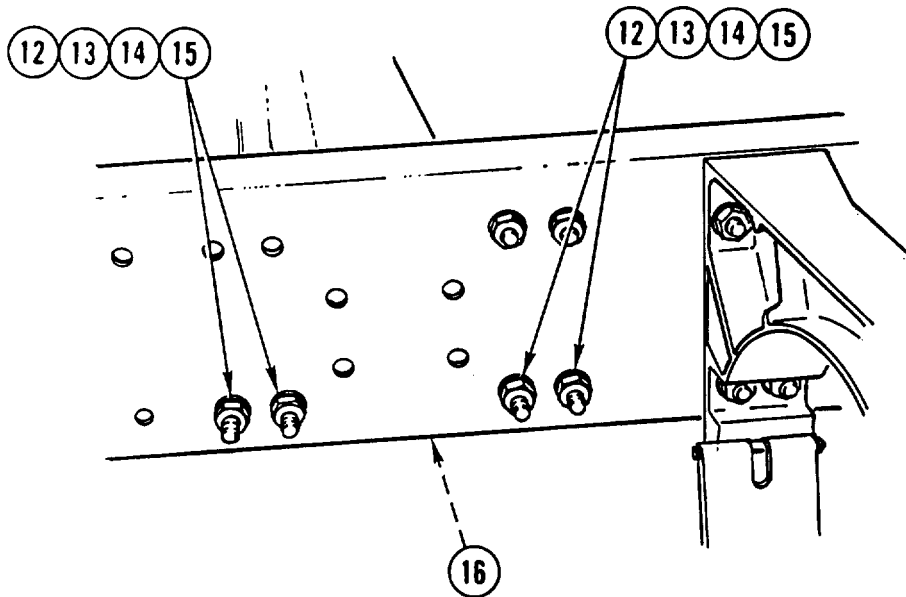

3. REMOVE EIGHT NUTS (12), EIGHT WASHERS (13), EIGHT CAPSCREWS (14), EIGHT WASHERS (15), AND TWO GUSSETS (16).

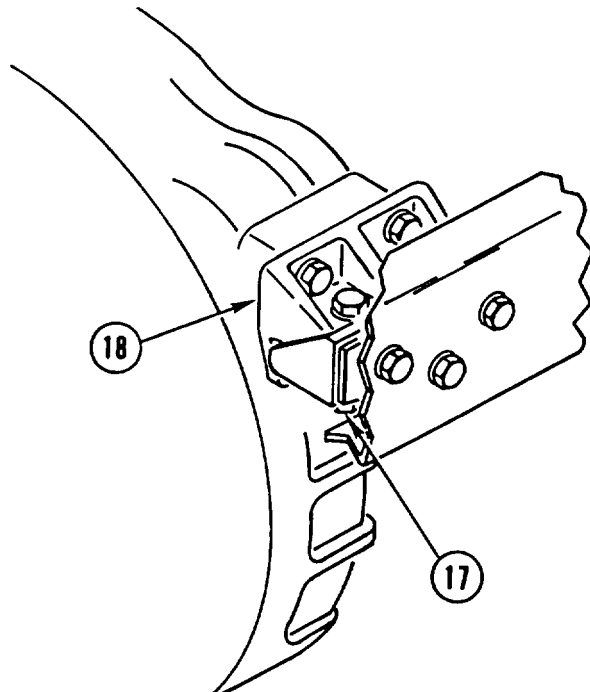

NOTE

During steps 4 and 5, loosen nuts only enough to allow removal of cab alligator crossmember.

4. LOOSEN FOUR NUTS (17) AT TWO REAR ENGINE MOUNTS (18).

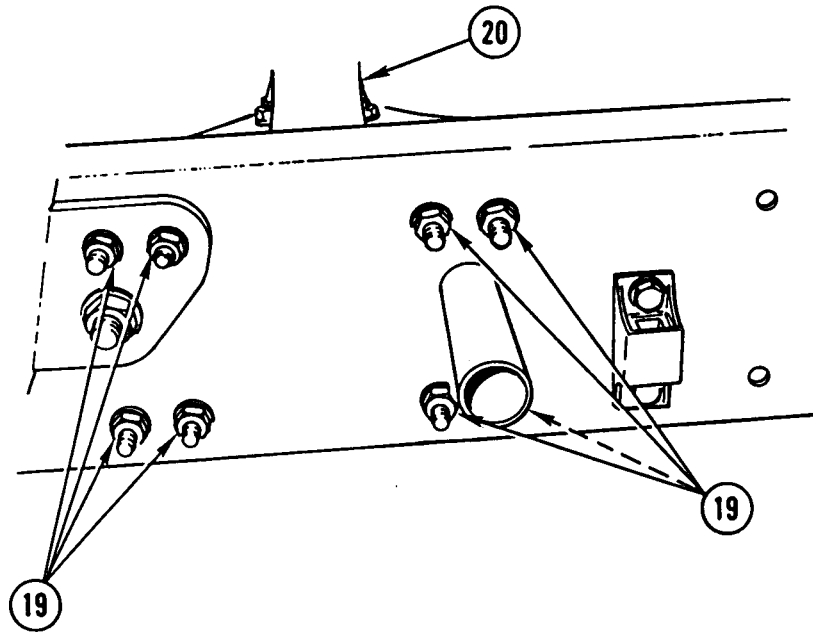

5. LOOSEN EIGHT NUTS (19) AT MIDSHIPS ALLIGATOR CROSSMEMBER (20).

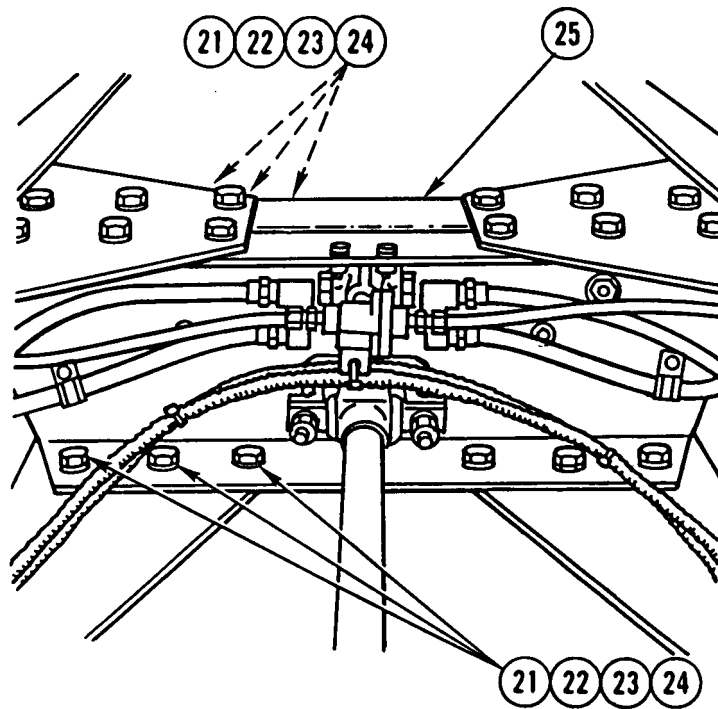

6. REMOVE SIX NUTS (21), SIX WASHERS (22), SIX CAPSCREWS (23), AND SIX WASHERS (24) FROM SUSPENSION CROSSMEMBER (25).

CAB ALLIGATOR CROSSMEMBER REPLACEMENT (CONT)

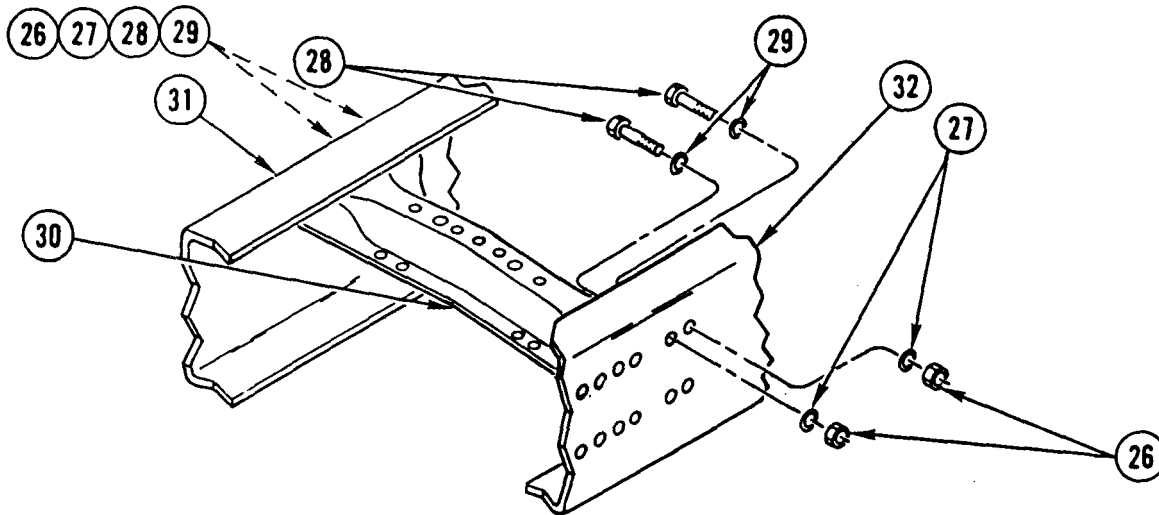

7. REMOVE FOUR NUTS (26), FOUR WASHERS (27), FOUR CAPSCREWS (28), AND FOUR WASHERS (29) FROM CAB ALLIGATOR CROSSMEMBER (30).
8. INSTALL HYDRAULIC SPREADER AT ANGLE GOING FROM INSIDE LOWER CORNER OF FRAME RAIL (31) TO INSIDE UPPER CORNER OF OPPOSITE FRAME RAIL (32).

NOTE

It may be necessary to further loosen nuts loosened in steps 4 and 5 if frame rails will not spread far enough apart to allow removal of cab alligator crossmember.

9. SLOWLY SPREAD FRAME RAILS (31 AND 32) ENOUGH TO ALLOW CAB ALLIGATOR CROSSMEMBER (30) TO BE TILTED AT AN ANGLE OPPOSITE OF HYDRAULIC SPREADER.

CAUTION

To prevent possible damage to frame rails, spread frame rails only enough to allow removal of cab alligator crossmember.

10. CONTINUE TO SPREAD FRAME RAILS (31 AND 32) UNTIL CAB ALLIGATOR CROSSMEMBER (30) CAN BE REMOVED.
11. REMOVE CAB ALLIGATOR CROSSMEMBER (30).

CLEANING

Use general cleaning methods to clean all parts (page 2-30).

INSPECTION

Inspect all parts for wear or damage.

INSTALLATION

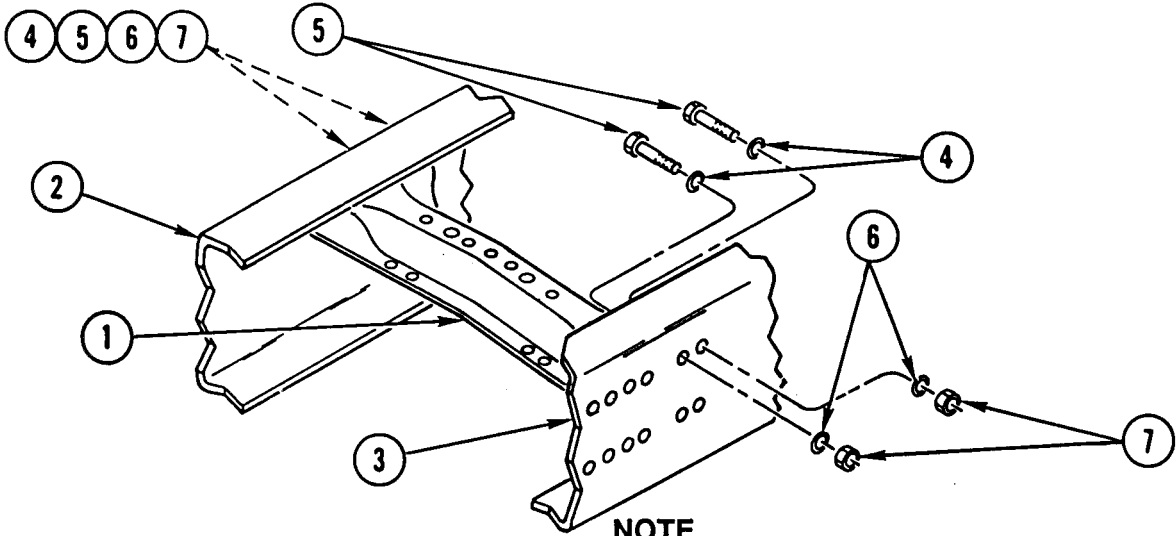

NOTE

Following procedure is done on right side of vehicle.

1. INSTALL CAB ALLIGATOR CROSSMEMBER (1) AT ANGLE OPPOSITE OF HYDRAULIC SPREADER BETWEEN FRAME RAILS (2 AND 3).
2. SLOWLY RELEASE PRESSURE ON HYDRAULIC SPREADER, AND AT SAME TIME, KEEP CAB ALLIGATOR CROSSMEMBER (1) ALINED WITH FRAME RAILS (2 AND 3).
3. REMOVE HYDRAULIC SPREADER FROM FRAME RAILS (2 AND 3).
4. INSTALL FOUR WASHERS (4), FOUR CAPSCREWS (5), FOUR WASHERS (6), AND FOUR NUTS (7) ON CAB ALLIGATOR CROSSMEMBER AND FRAME RAILS (2 AND 3).

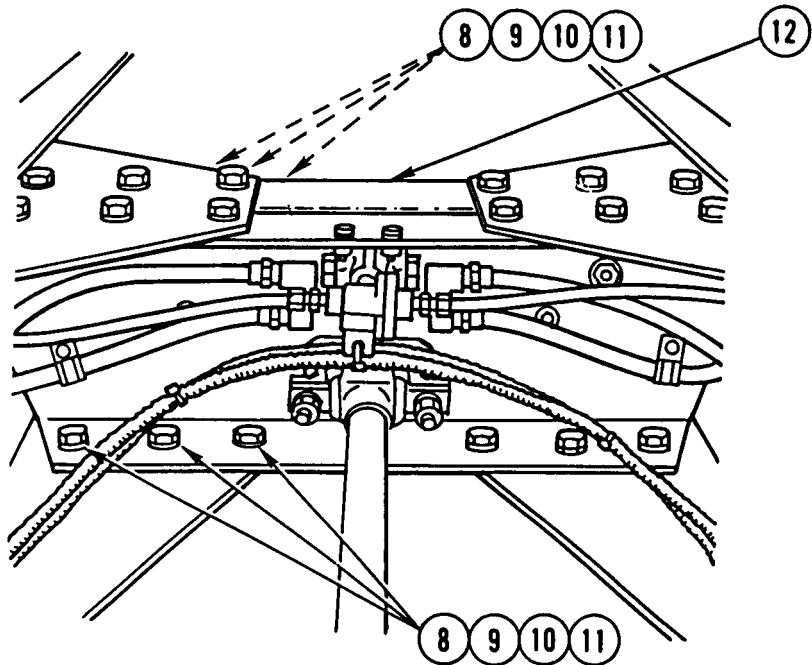

5. INSTALL SIX WASHERS (8), SIX CAPSCREWS (9), SIX WASHERS (10), AND SIX NUTS (11) AT SUSPENSION CROSSMEMBER (12).

CAB ALLIGATOR CROSSMEMBER REPLACEMENT (CONT)

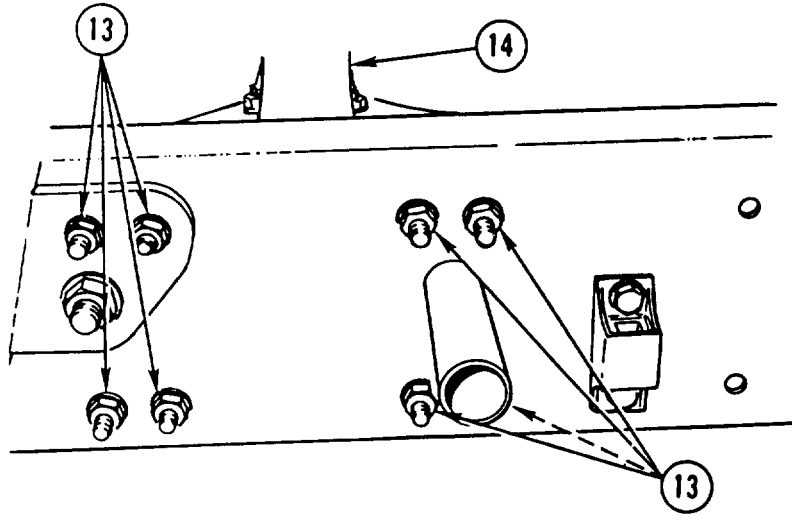

6. TIGHTEN EIGHT NUTS (13) AT MIDSHIPS ALLIGATOR CROSSMEMBER (14).

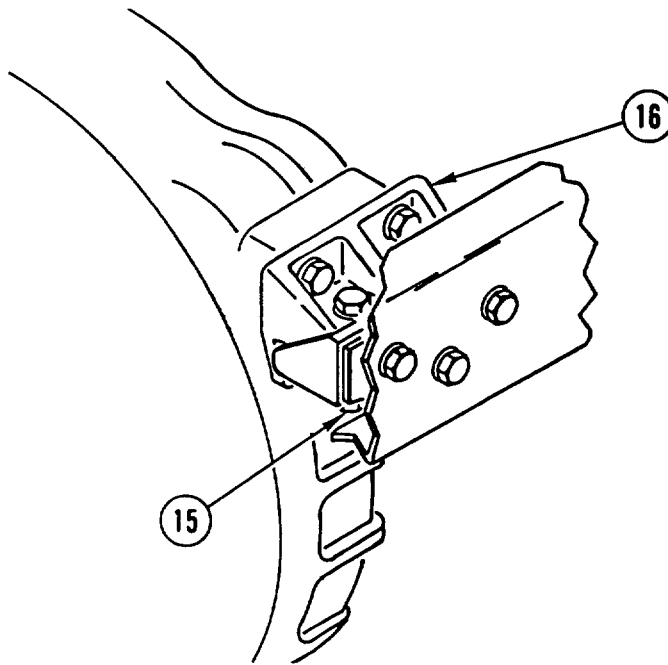

7. TIGHTEN FOUR NUTS (15) AT REAR ENGINE MOUNTS (16).

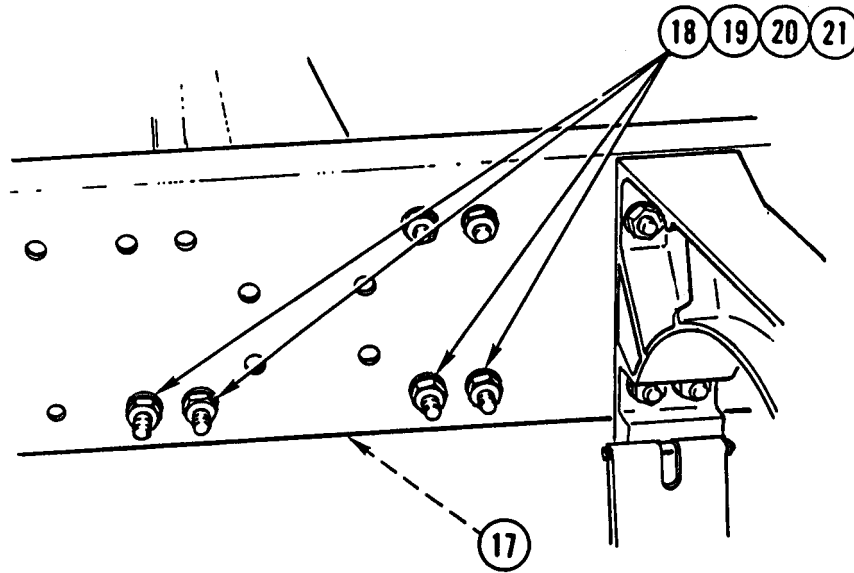

8. INSTALL TWO GUSSETS (17), EIGHT WASHERS (18), EIGHT CAPSCREWS (19), EIGHT WASHERS (20), AND EIGHT NUTS (21).

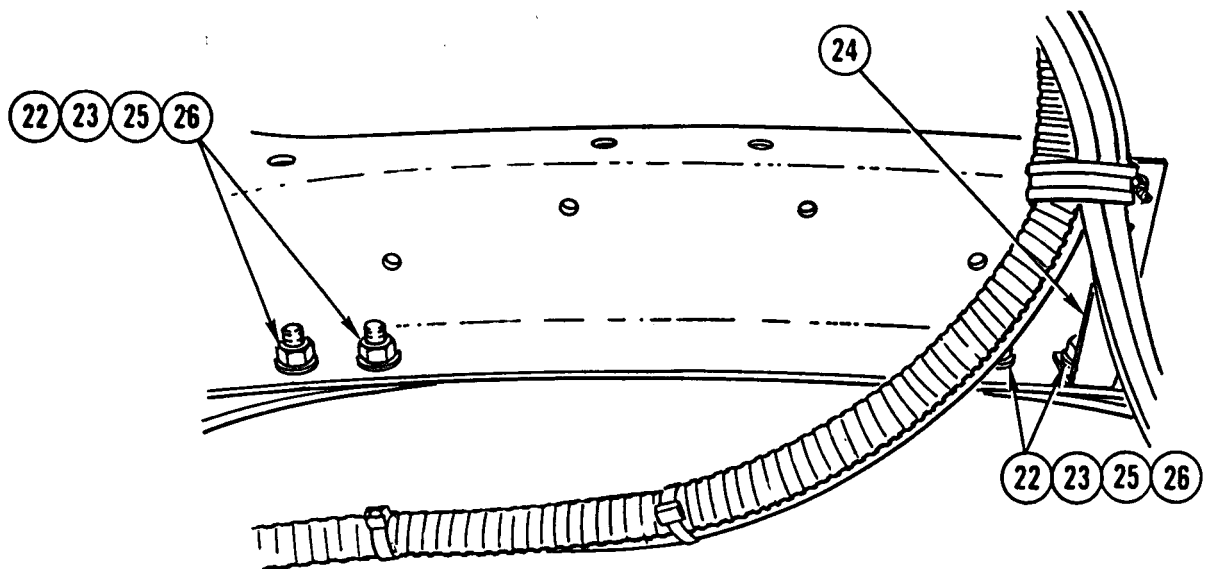

9. INSTALL FOUR WASHERS (22), FOUR CAPSCREWS (23), BRACKET (24), FOUR WASHERS (25), AND FOUR NUTS (26).

CAB ALLIGATOR CROSSMEMBER REPLACEMENT (CONT)

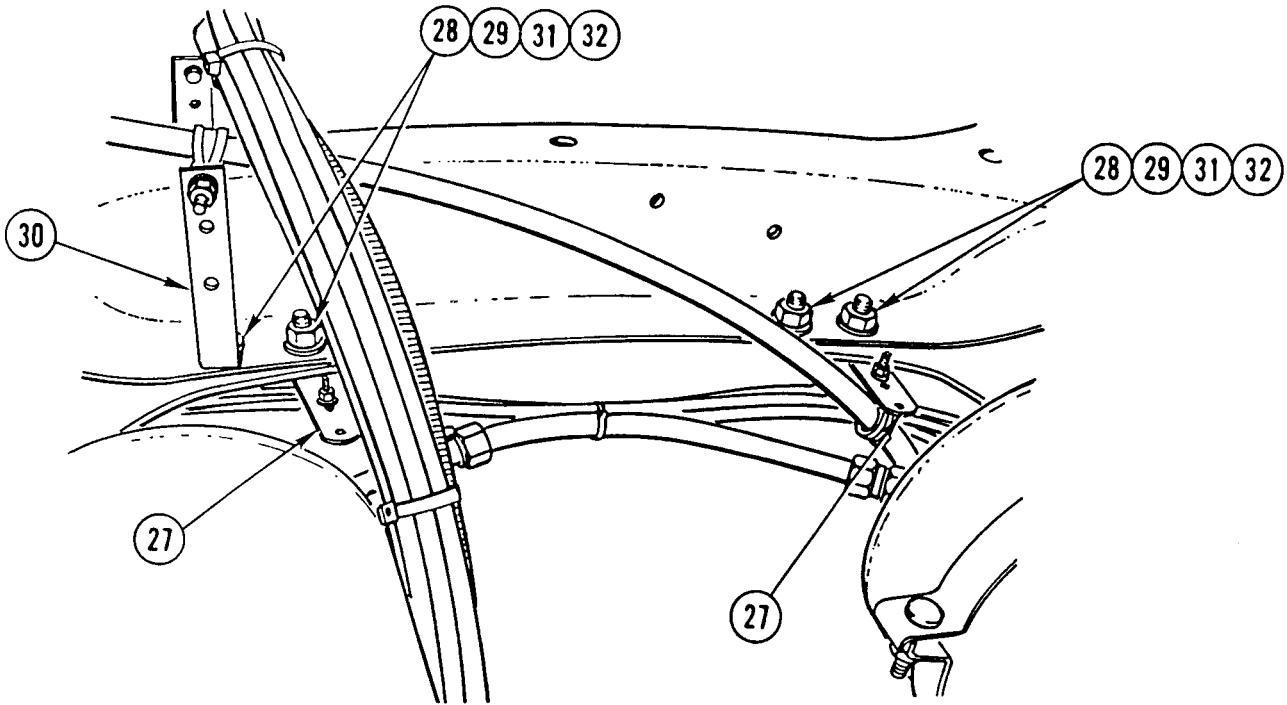

10. INSTALL TWO BRACKETS (27), FOUR WASHERS (28), FOUR CAPSCREWS (29), BRACKET (30), FOUR WASHERS (31), AND FOUR NUTS (32).

NOTE

Follow-on Maintenance:

- Install spare wheel hoist (TM 9-2320-363-20).
- Install left side platform (TM 9-2320-363-20).
- Install personal gear storage box and mounting bracket (TM 9-2320-363-20).
- Install air dryer (TM 9-2320-363-20).
- Install rear platform (TM 9-2320-363-20).
- Install forward driveline (TM 9-2320-363-20).
- Install fifth wheel (page 20-3).
- Install overslung crossmember (page 8-25).
- Install rear cab mounts (page 10-49).
- Install rear crossmember (page 8-15).

CAB ALLIGATOR CROSSMEMBER REPLACEMENT

This task covers: a. Removal b. Cleaning c. Inspection d. Installation

INITIAL SETUP

Applicable Configuration:

All except M915A2

Tools and Special Equipment:

Shop Equipment, SC 4910-95-CL-A31

Tool Kit, SC 5180-90-CL-N05

Personnel Required: (3)

References:

TM 9-2320-363-20

Equipment Condition:

Reference	Condition Description
TM 9-2320-363-20	Fuel Tank Removed
Page 11-34	Hydraulic Winch Frame Removed
Page 3-263	Transfer Case Removed
Page 20-6	Fifth Wheel Removed

Equipment Condition (Cont):

Reference	Condition Description
Page 8-25	Overslung Crossmember Removed
Page 10-49	Rear Cab Mounts Removed
Page 8-20	Rear Crossmember Removed

CAB ALLIGATOR CROSSMEMBER REPLACEMENT (CONT)

REMOVAL

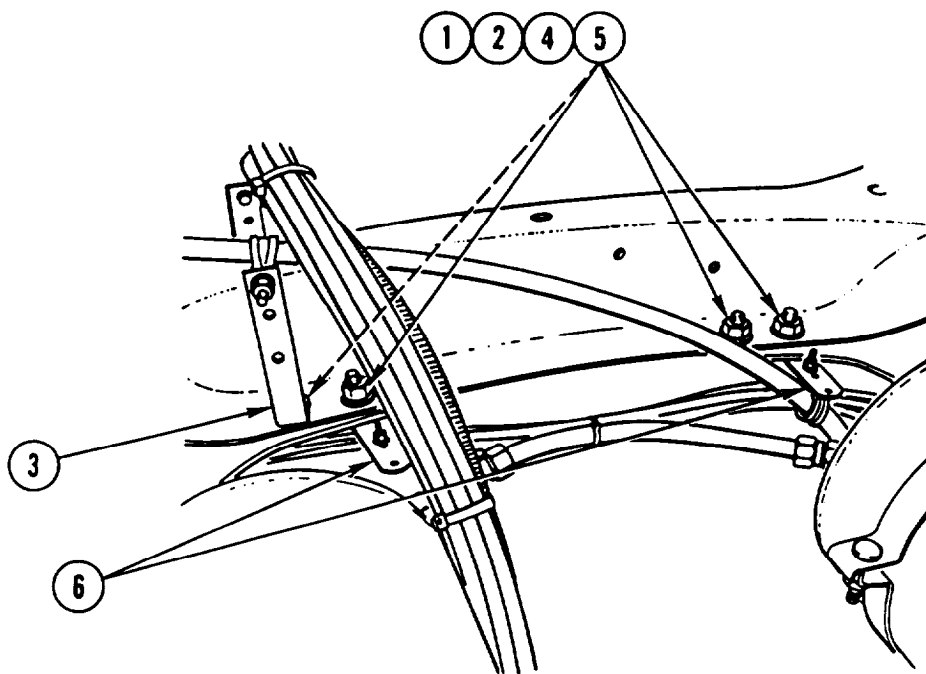

NOTE

Procedure is done on right side of vehicle.

1. REMOVE FOUR NUTS (1), FOUR WASHERS (2), BRACKET (3), FOUR CAPSCREWS (4), FOUR WASHERS (5), AND TWO BRACKETS (6). SET BRACKETS (3 AND 6) ASIDE.

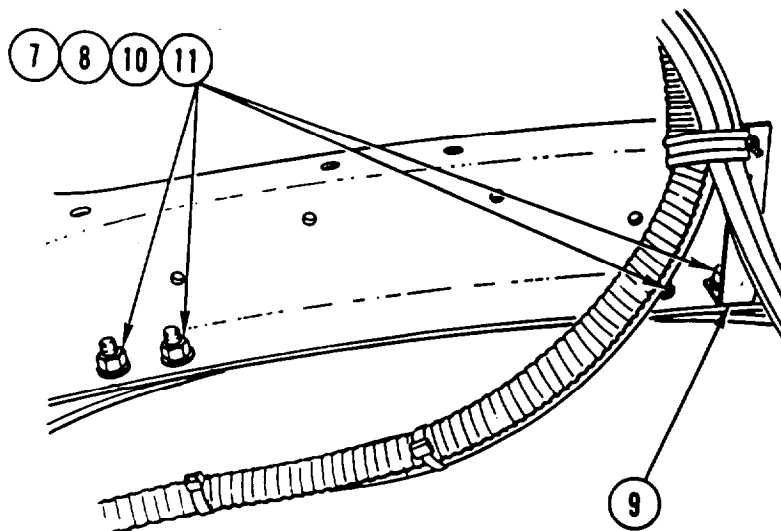

2. REMOVE FOUR NUTS (7), FOUR WASHERS (8), BRACKET (9), FOUR CAPSCREWS (10), AND FOUR WASHERS (11). SET BRACKET ASIDE.

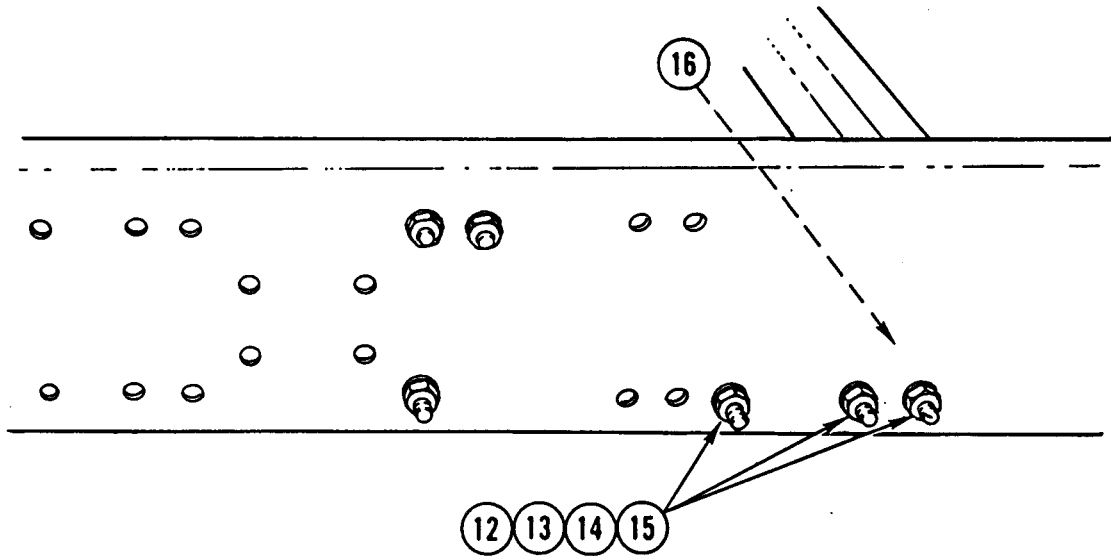

3. REMOVE SEVEN NUTS (12), SEVEN WASHERS (13), SEVEN CAPSCREWS (14), SEVEN WASHERS (15), AND TWO GUSSETS (16).

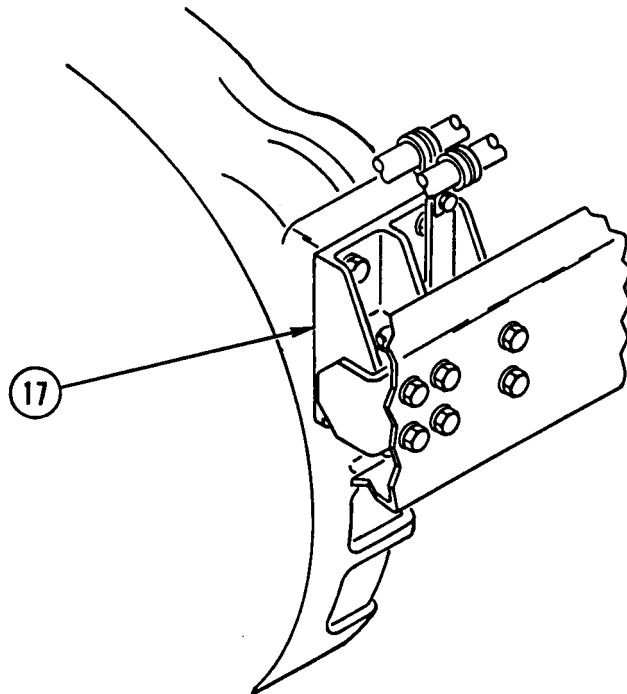

4. REMOVE RIGHT REAR ENGINE MOUNT (17) IN ACCORDANCE WITH PROCEDURE ON PAGE 3-52.

CAB ALLIGATOR CROSSMEMBER REPLACEMENT (CONT)

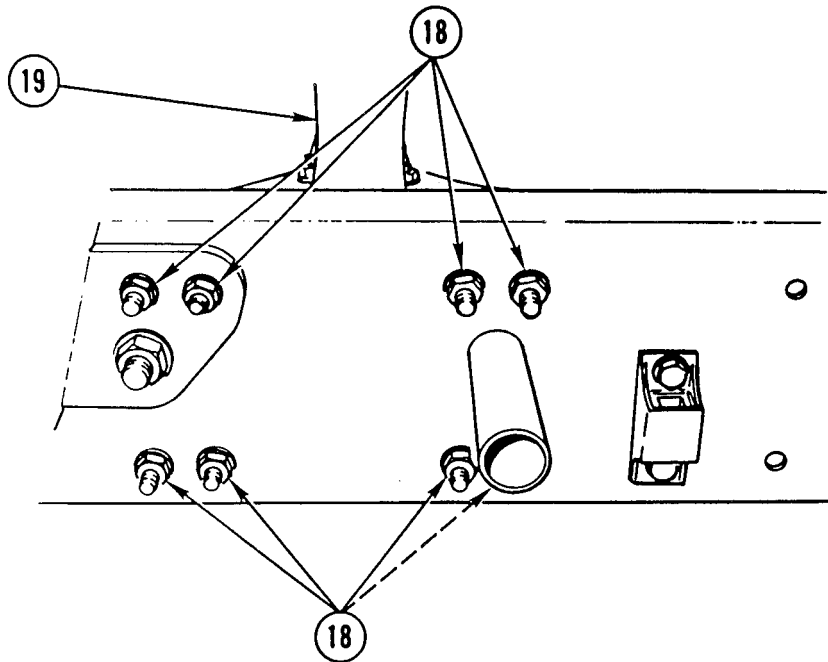

NOTE

Loosen nuts only enough to allow removal of cab alligator crossmember.

5. LOOSEN EIGHT NUTS (18) AT MIDSHIPS ALLIGATOR CROSSMEMBER (19).

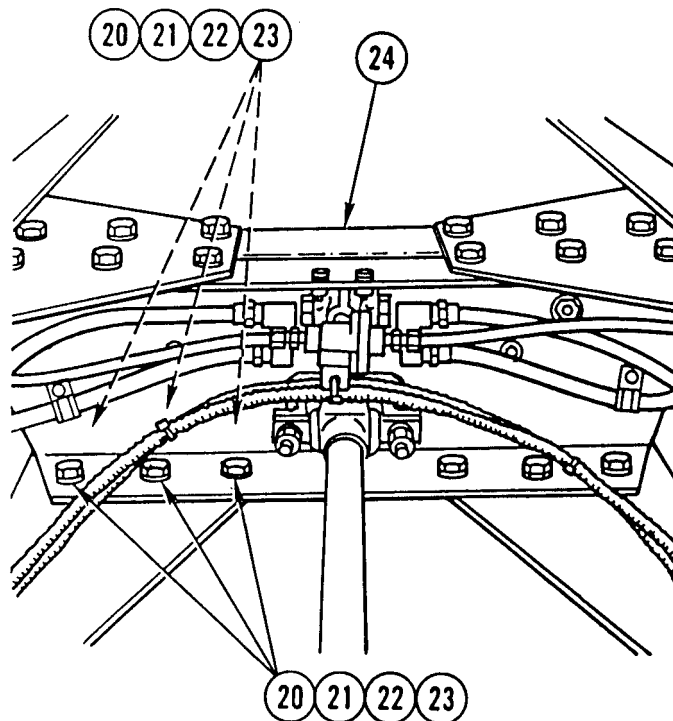

6. REMOVE SIX NUTS (20), SIX WASHERS (21), SIX CAPSCREWS (22), AND SIX WASHERS (23) FROM SUSPENSION CROSSMEMBER (24).

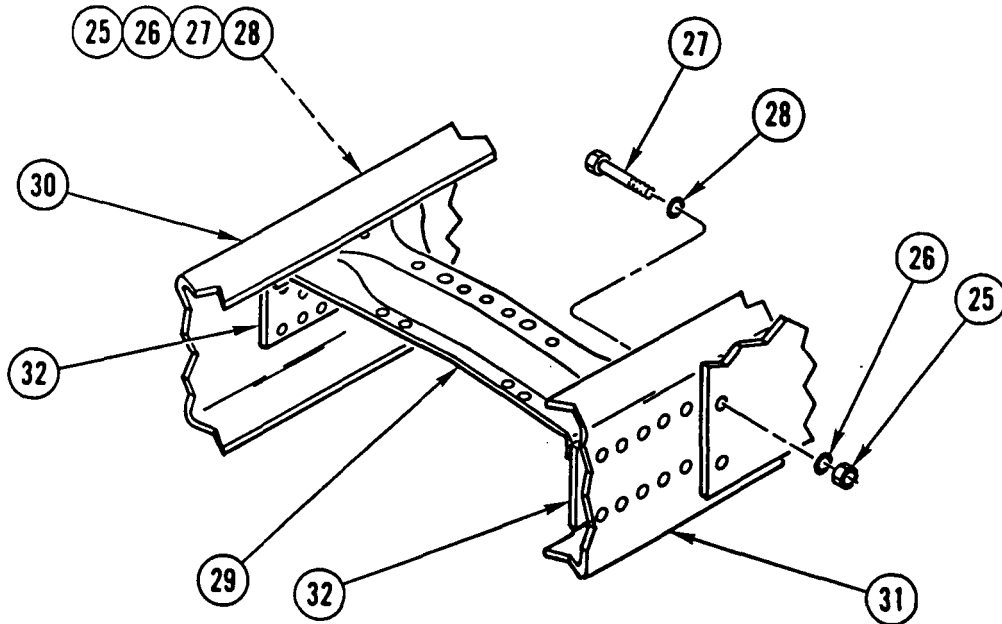

7. REMOVE SIX NUTS (25), SIX WASHERS (26), SIX CAPSCREWS (27), AND SIX WASHERS (28) FROM CAB ALLIGATOR CROSSMEMBER (29).
8. INSTALL HYDRAULIC SPREADER AT ANGLE GOING FROM INSIDE LOWER CORNER OF FRAME RAIL (30) TO INSIDE UPPER CORNER OF OPPOSITE FRAME RAIL (31).

NOTE

It may be necessary to further loosen nuts loosened in step 5 if frame rails will not spread far enough apart to allow removal of cab alligator crossmember.

9. SLOWLY SPREAD FRAME RAILS (30 AND 31) ENOUGH TO ALLOW CAB ALLIGATOR CROSSMEMBER (29) TO BE TILTED AT ANGLE OPPOSITE OF HYDRAULIC SPREADER.

CAUTION

To prevent possible damage to frame rails, spread frame rails only enough to allow removal of cab alligator crossmember.

10. CONTINUE TO SPREAD FRAME RAILS (30 AND 31) UNTIL CAB ALLIGATOR CROSSMEMBER (29) CAN BE REMOVED.
11. REMOVE TWO SPACERS (32) FROM FRAME RAILS (30 AND 31).

CLEANING

Use general cleaning methods to clean all parts (page 2-30).

INSPECTION

Inspect all parts for wear or damage.

CAB ALLIGATOR CROSSMEMBER REPLACEMENT (CONT)

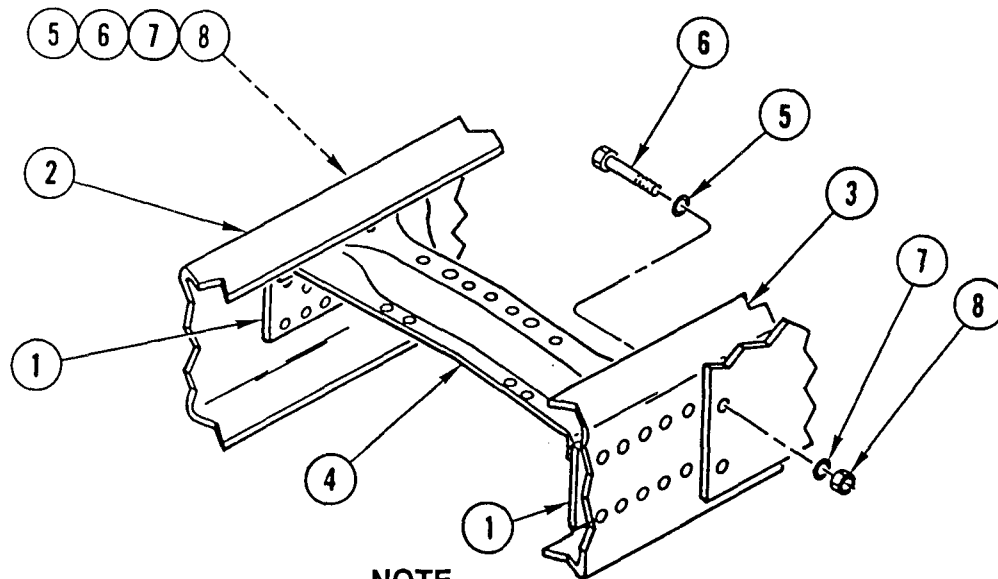

NOTE

Procedure is done on right side of vehicle.

1. INSTALL TWO SPACERS (1) ON FRAME RAILS (2 AND 3).
2. INSTALL CAB ALLIGATOR CROSSMEMBER (4) AT ANGLE OPPOSITE OF HYDRAULIC SPREADER BETWEEN FRAME RAILS (2 AND 3).
3. SLOWLY RELEASE PRESSURE ON HYDRAULIC SPREADER, AND AT SAME TIME, KEEP CAB ALLIGATOR CROSSMEMBER (4) ALINED WITH FRAME RAILS (2 AND 3).
4. REMOVE HYDRAULIC SPREADER FROM FRAME RAILS (2 AND 3).
5. INSTALL SIX WASHERS (5), SIX CAPSCREWS (6), SIX WASHERS (7), AND SIX NUTS (8) ON CAB ALLIGATOR CROSSMEMBER (4) AND FRAME RAILS (2 AND 3).

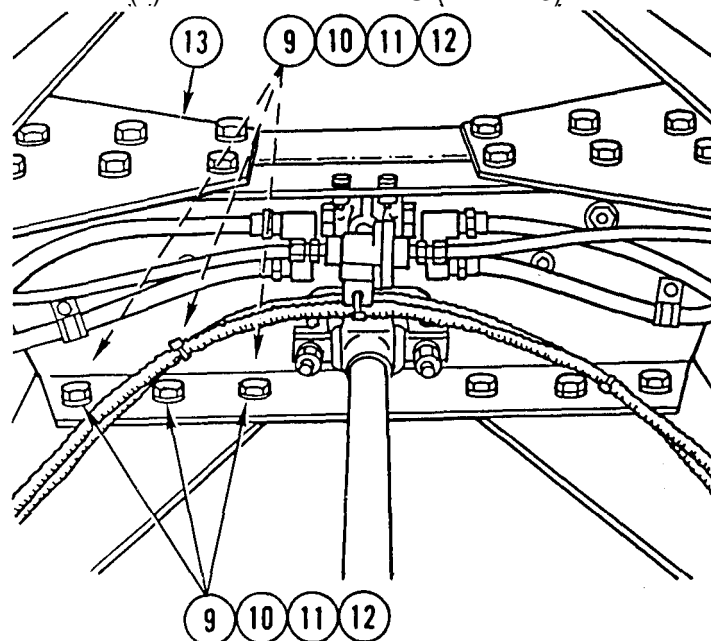

6. INSTALL SIX WASHERS (9), SIX CAPSCREWS (10), SIX WASHERS (11), AND SIX NUTS (12) ON SUSPENSION CROSSMEMBER (13).

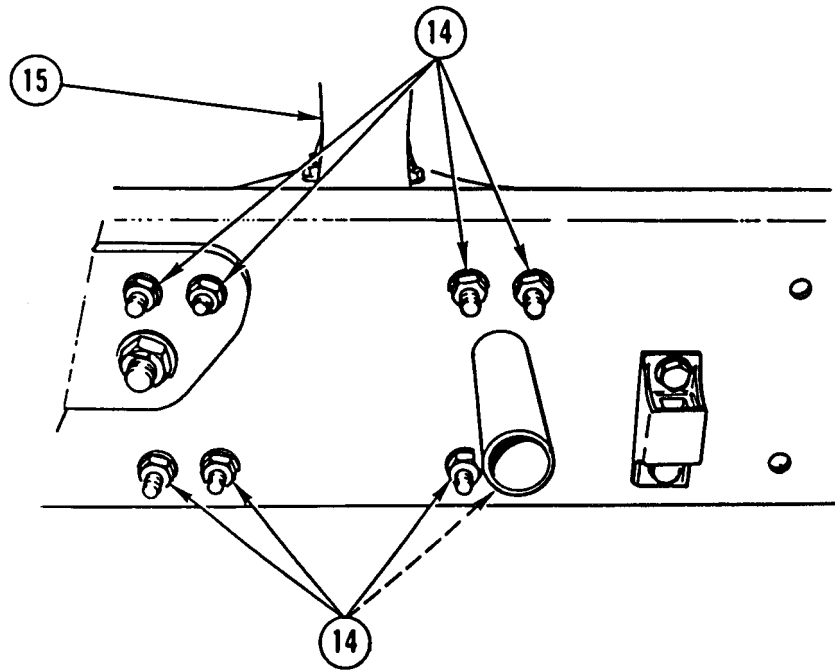

7. TIGHTEN EIGHT NUTS (14) AT MIDSHIPS ALLIGATOR CROSSMEMBER (15).

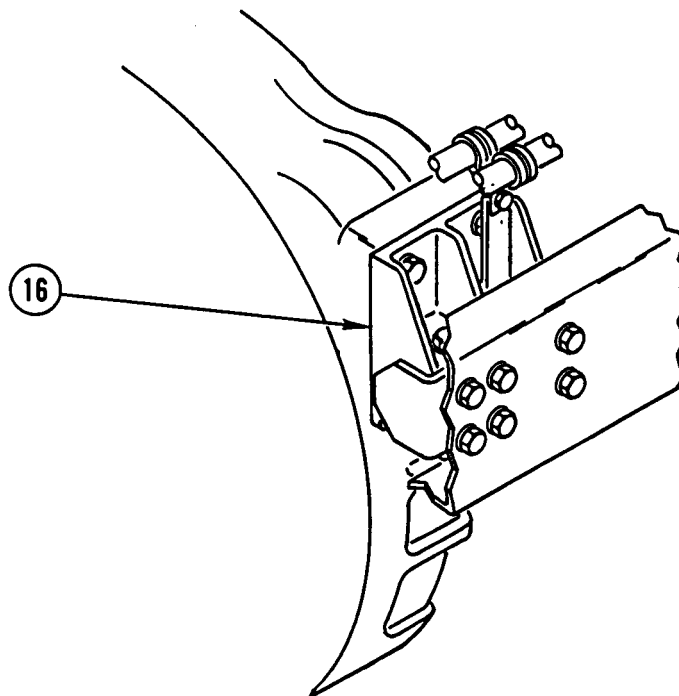

8. INSTALL RIGHT REAR ENGINE MOUNT (16) IN ACCORDANCE WITH PROCEDURE ON PAGE 3-52.

CAB ALLIGATOR CROSSMEMBER REPLACEMENT (CONT)

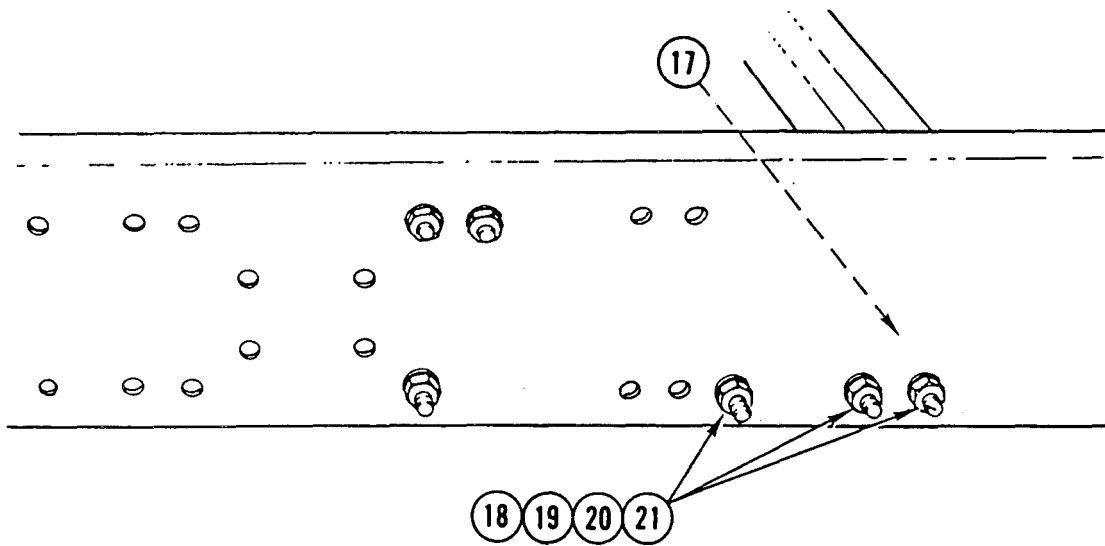

9. INSTALL TWO GUSSETS (17), SEVEN WASHERS (18), SEVEN CAPSCREWS (19), SEVEN WASHERS (20), AND SEVEN NUTS (21).

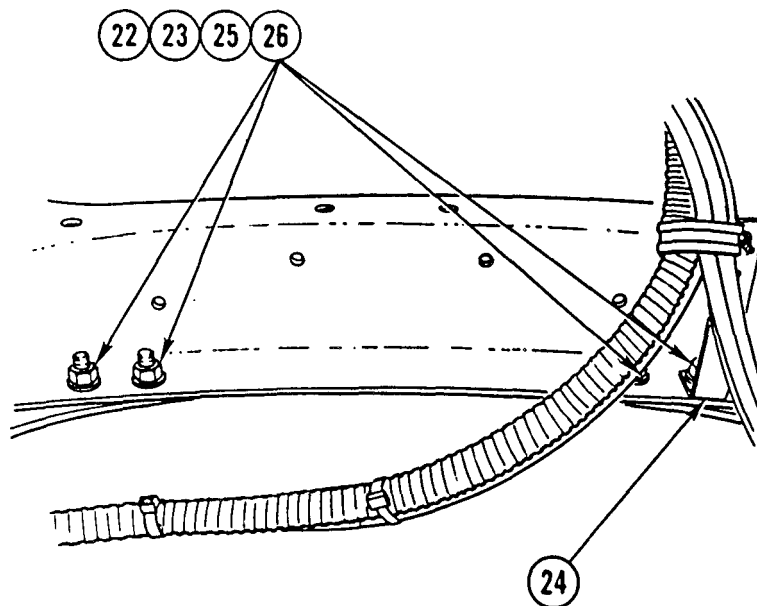

10. INSTALL FOUR WASHERS (22), FOUR CAPSCREWS (23), BRACKET (24), FOUR WASHERS (25), AND FOUR NUTS (26).

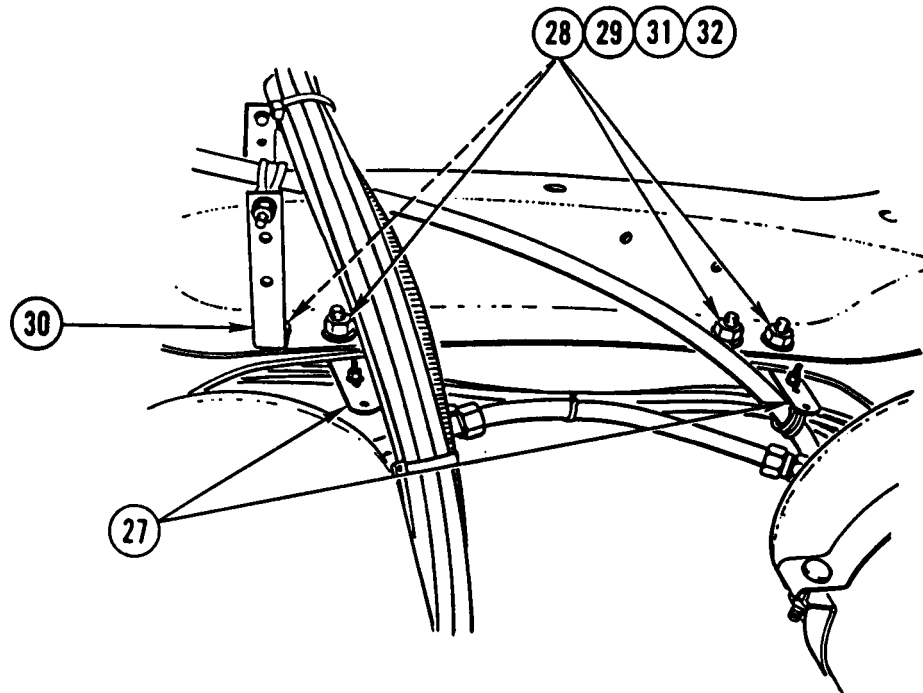

11. INSTALL TWO BRACKETS (27), FOUR WASHERS (28), FOUR CAPSCREWS (29), BRACKET (30), FOUR WASHERS (31), AND FOUR NUTS (32).

NOTE

Follow-on Maintenance:

- Install fuel tank (TM 9-2320-363-20).
- Install hydraulic winch frame (page 11-34).
- Install transfer case (page 3-263).
- install fifth wheel (page 20-6).
- Install overslung crossmember (page 8-25).
- Install rear cab mounts (page 10-49).
- Install rear crossmember (page 8-20).

MIDSHIPS ALLIGATOR CROSSMEMBER REPLACEMENT

This task covers: a. Removal b. Cleaning c. Inspection d. Installation

INITIAL SETUP

Applicable Configuration:

M915A2

Tools and Special Equipment:

Shop Equipment, SC 4910-95-CL-A31
 Tool Kit, SC 5180-90-CL-N05

Personnel Required: (3)

References:

TM 9-2320-363-20

Equipment Condition:

Reference	Condition Description
TM 9-2320-363-20	Left Side Platform Removed
TM 9-2320-363-20	Personal Gear Storage Box and Mounting Bracket Removed
TM 9-2320-363-20	Air Dryer Removed
TM 9-2320-363-20	Rear Platform Removed
TM 9-2320-363-20	Right Rear Fender Removed
Page 20-3	Fifth Wheel Removed
Page 8-15	Rear Crossmember Removed

REMOVAL

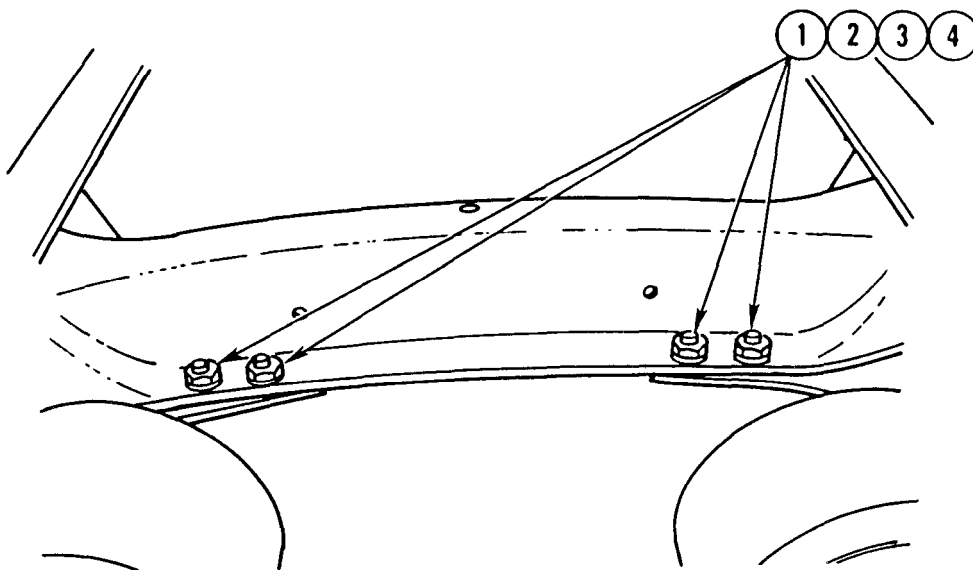

NOTE

Procedure is done on right side of vehicle.

1. REMOVE FOUR NUTS (1), FOUR WASHERS (2), FOUR CAPSCREWS (3), AND FOUR WASHERS (4).

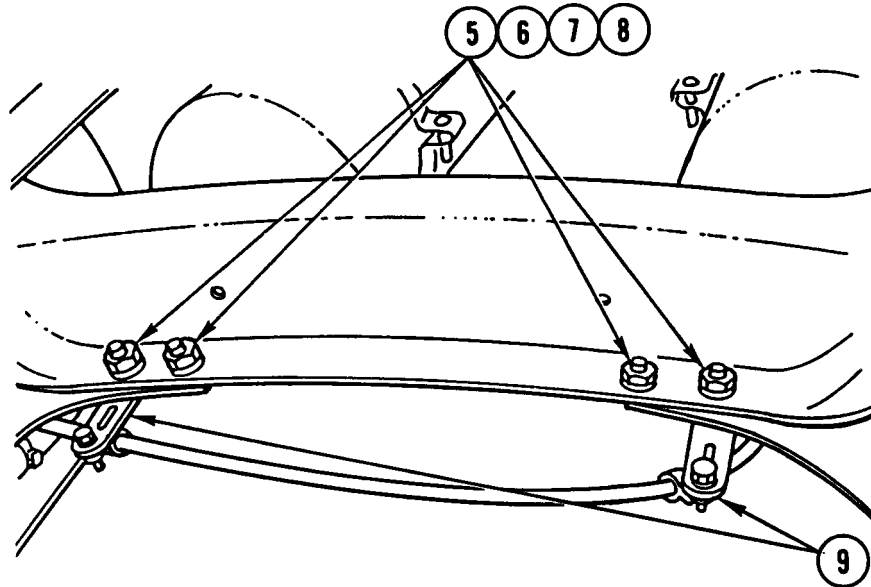

2. REMOVE FOUR NUTS (5), FOUR WASHERS (6), FOUR CAPSCREWS (7), FOUR WASHERS (8), AND TWO BRACKETS (9). SET BRACKETS (9) ASIDE.

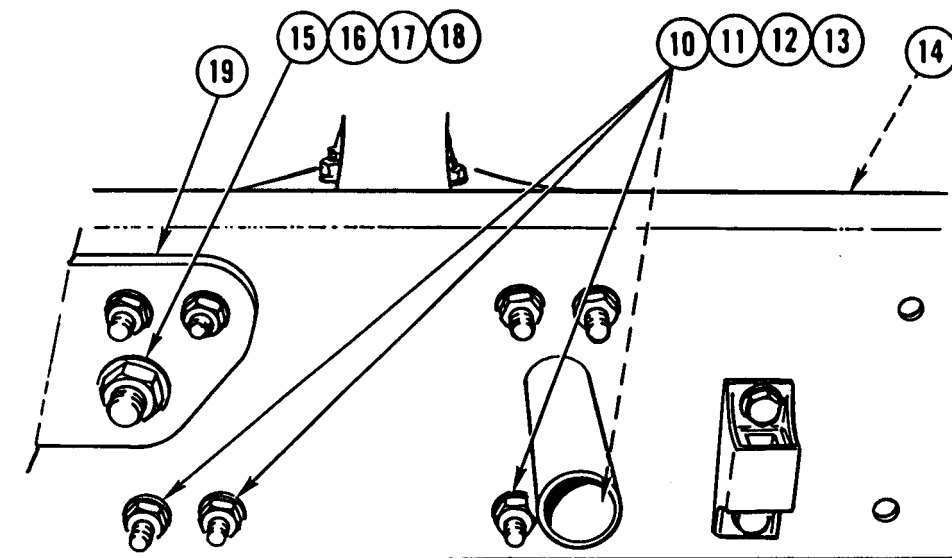

3. REMOVE EIGHT NUTS (10), EIGHT WASHERS (11), EIGHT CAPSCREWS (12), EIGHT WASHERS (13), AND TWO GUSSETS (14).
4. REMOVE NUT (15), WASHER (16), CAPSCREW (17), AND WASHER (18) FROM LIFTING BRACKET (19).

MIDSHIPS ALLIGATOR CROSSMEMBER REPLACEMENT (CONT)

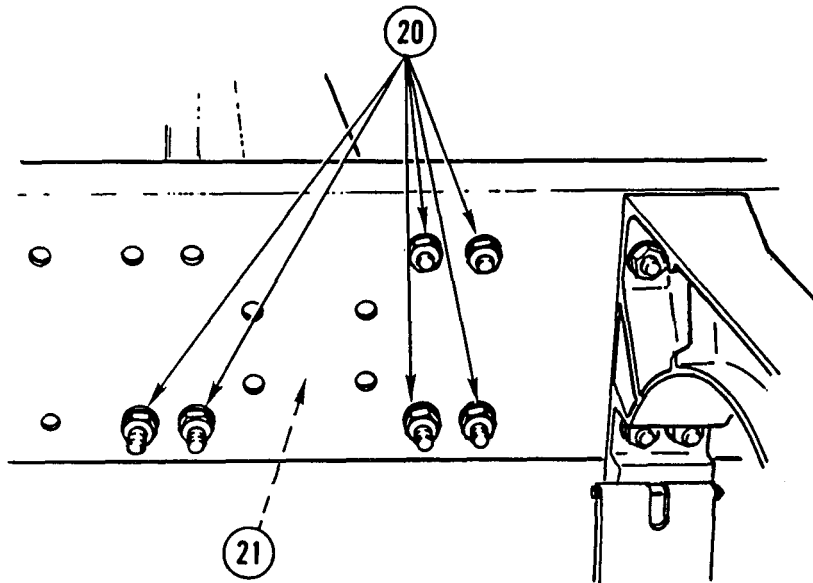

NOTE

Loosen nuts only enough to allow removal of midships alligator crossmember.

5. LOOSEN SIX NUTS (20) ON CAB ALLIGATOR CROSSMEMBER (21).

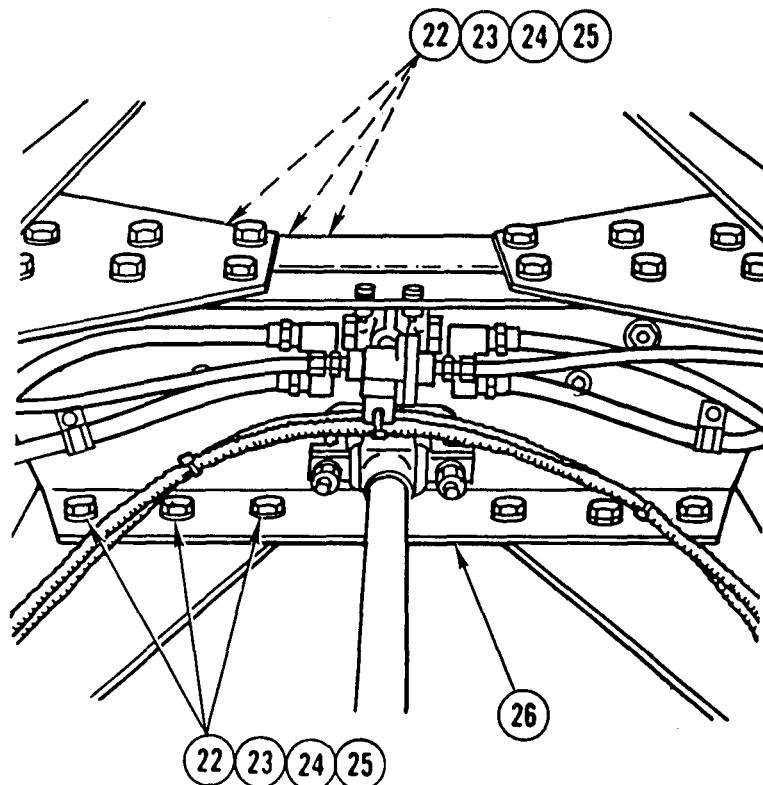

6. REMOVE SIX NUTS (22), SIX WASHERS (23), SIX CAPSCREWS (24), AND SIX WASHERS (25) FROM SUSPENSION CROSSMEMBER (26).

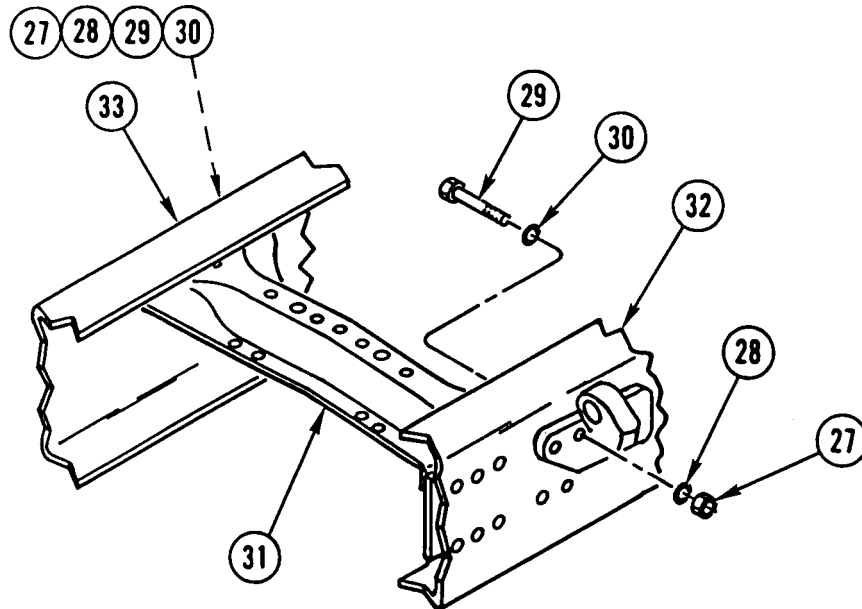

7. REMOVE EIGHT NUTS (27), EIGHT WASHERS (28), EIGHT CAPSCREWS (29), AND EIGHT WASHERS (30) FROM MIDSHIPS ALLIGATOR CROSSMEMBER (31).
8. INSTALL HYDRAULIC SPREADER AT ANGLE GOING FROM INSIDE LOWER CORNER OF LEFT FRAME RAIL (32) TO INSIDE UPPER CORNER OF RIGHT FRAME RAIL (33).

NOTE

It may be necessary to further loosen nuts loosened in step 5 if frame rails will not spread far enough apart to allow removal of midships alligator crossmember.

9. SLOWLY SPREAD TWO FRAME RAILS (32 AND 33) ENOUGH TO ALLOW MIDSHIPS ALLIGATOR CROSSMEMBER (31) TO BE TILTED AT ANGLE OPPOSITE OF HYDRAULIC SPREADER.

CAUTION

To prevent possible damage to frame rails, spread frame rails only enough to allow removal of midships alligator crossmember.

10. CONTINUE TO SPREAD TWO FRAME RAILS (32 AND 33) UNTIL MIDSHIPS ALLIGATOR CROSSMEMBER (31) CAN BE REMOVED.
11. REMOVE MIDSHIPS ALLIGATOR CROSSMEMBER (31).

MIDSHIPS ALLIGATOR CROSSMEMBER REPLACEMENT (CONT)

CLEANING

Use general cleaning methods to clean all parts (page 2-30).

INSPECTION

Inspect all pads for wear or damage.

INSTALLATION

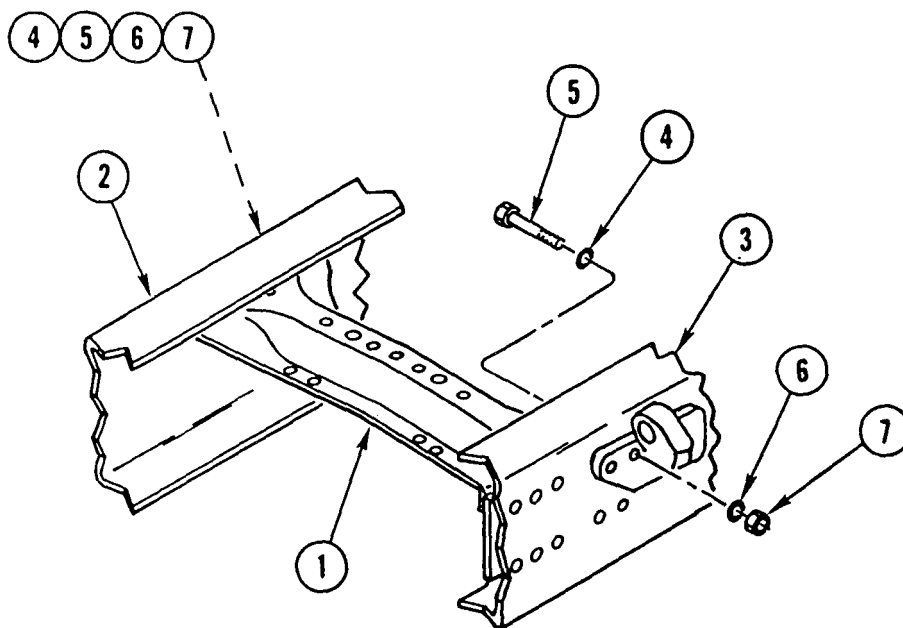

NOTE

Procedure is done on right side of vehicle.

1. INSTALL MIDSHIPS ALLIGATOR CROSSMEMBER (1) AT ANGLE OPPOSITE OF HYDRAULIC SPREADER BETWEEN TWO FRAME RAILS (2 AND 3).
2. SLOWLY RELEASE PRESSURE ON HYDRAULIC SPREADER, AND AT SAME TIME, KEEP MIDSHIPS ALLIGATOR CROSSMEMBER (1) ALINED WITH TWO FRAME RAILS (2 AND 3).
3. REMOVE HYDRAULIC SPREADER FROM TWO FRAME RAILS (2 AND 3).
4. INSTALL EIGHT WASHERS (4), EIGHT CAPSCREWS (5), EIGHT WASHERS (6), AND EIGHT NUTS (7) ON MIDSHIPS ALLIGATOR CROSSMEMBER (1) AND TWO FRAME RAILS (2 AND 3).

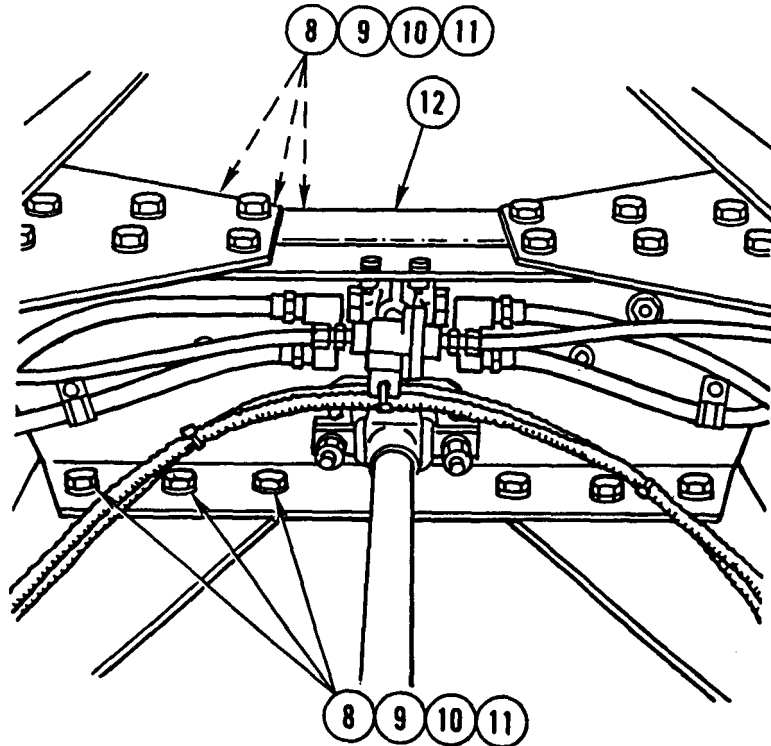

5. INSTALL SIX WASHERS (8), SIX CAPSCREWS (9), SIX WASHERS (10), AND SIX NUTS (11) ON SUSPENSION CROSSMEMBER (12).

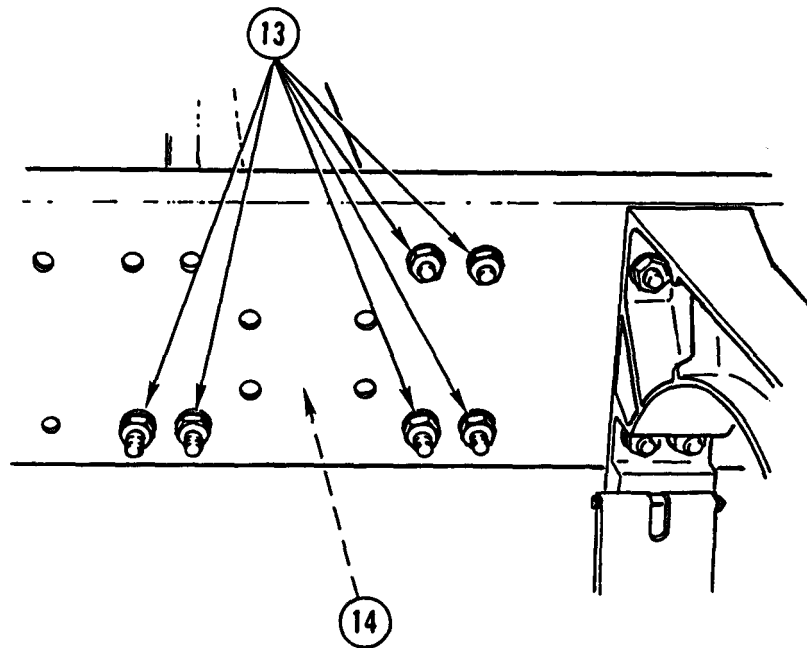

6. TIGHTEN SIX NUTS (13) ON CAB ALLIGATOR CROSSMEMBER (14).

MIDSHIPS ALLIGATOR CROSSMEMBER REPLACEMENT (CONT)

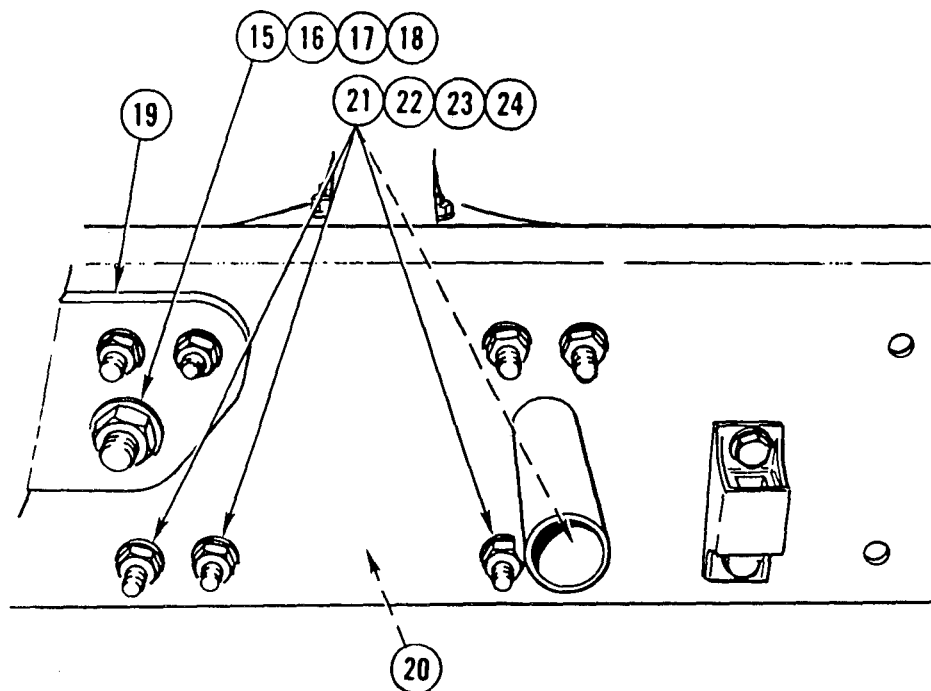

7. INSTALL WASHER (15), CAPSCREW (16), WASHER (17), AND NUT (18) ON LIFTG BRACKET (19).
8. INSTALL TWO GUSSETS (20), EIGHT WASHERS (21), EIGHT CAPSCREWS (22), EIGHT WASHERS (23), AND EIGHT NUTS (24).

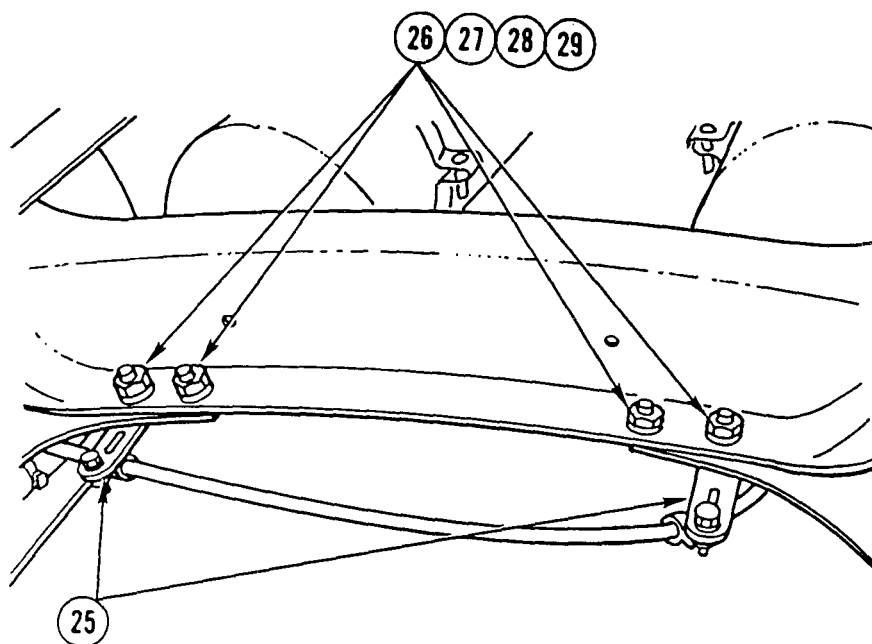

9. INSTALL TWO BRACKETS (25), FOUR WASHERS (26), FOUR CAPSCREWS (27), FOUR WASHERS (28), AND FOUR NUTS (29).

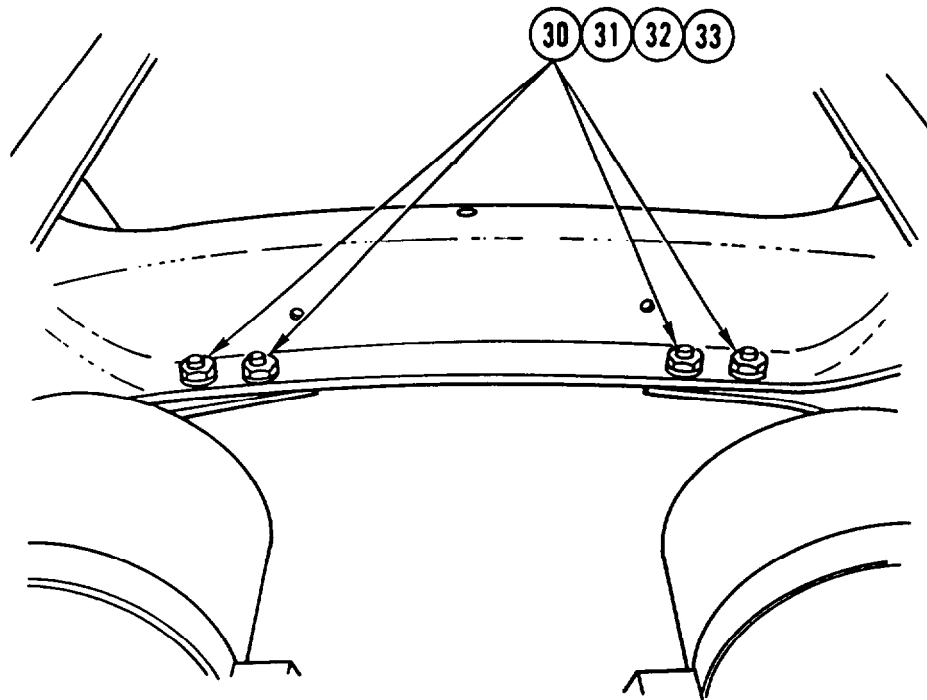

10. INSTALL FOUR WASHERS (30), FOUR CAPSCREWS (31), FOUR WASHERS (32), AND FOUR NUTS (33).

NOTE

Follow-on Maintenance:

- Install left side platform (TM 9-2320-363-20).
- Install personal gear storage box and mounting bracket (TM 9-2320-363-20).
- Install air dryer (TM 9-2320-363-20).
- Install rear platform (TM 9-2320-363-20).
- Install right rear fender (TM 9-2320-363-20).
- install fifth wheel (page 20-3).
- Install rear crossmember (page 8-15).

MIDSHIPS ALLIGATOR CROSSMEMBER REPLACEMENT

This task covers: a. Removal b. Cleaning c. Inspection d. Installation

INITIAL SETUP

Applicable Configuration:

All except M915A2

Tools and Special Equipment:

Shop Equipment, SC 4910-95-CL-A31

Tool Kit, SC 5180-90-CL-N05

Personnel Required: (3)

References:

TM 9-2320-363-10

TM 9-2320-363-20

Equipment Condition:

Reference

TM 9-2320-363-20

TM 9-2320-363-20

Page 11-34

Page 3-263

Page 20-6

Page 8-25

Page 8-20

Condition Description

Fuel Tank Drained

Rear Fender Removed

Hydraulic Winch Frame
Removed

Transfer Case Removed

Fifth Wheel Removed

Overslung Crossmember
Removed

Rear Crossmember
Removed

REMOVAL

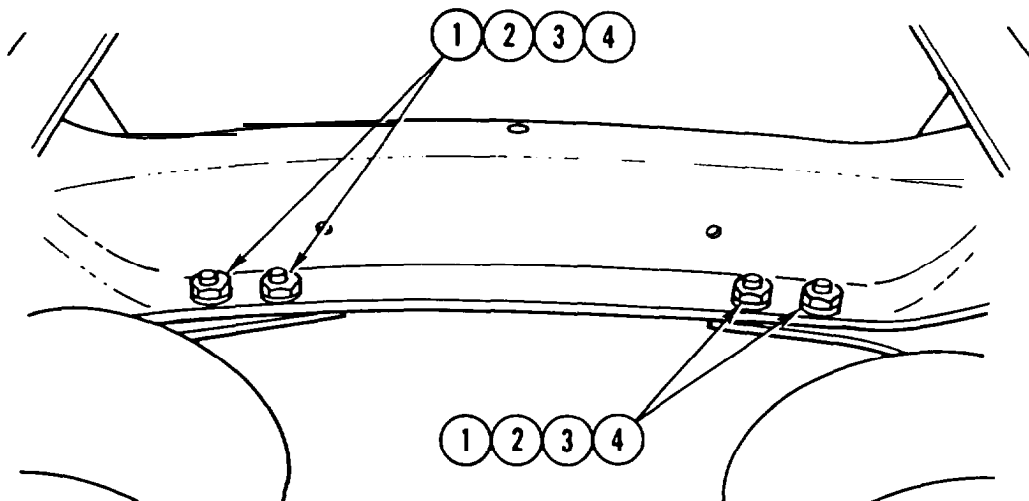

NOTE

Procedure is done on right side of vehicle.

1. REMOVE FOUR NUTS (1), FOUR WASHERS (2), FOUR CAPSCREWS (3), AND FOUR WASHERS (4).

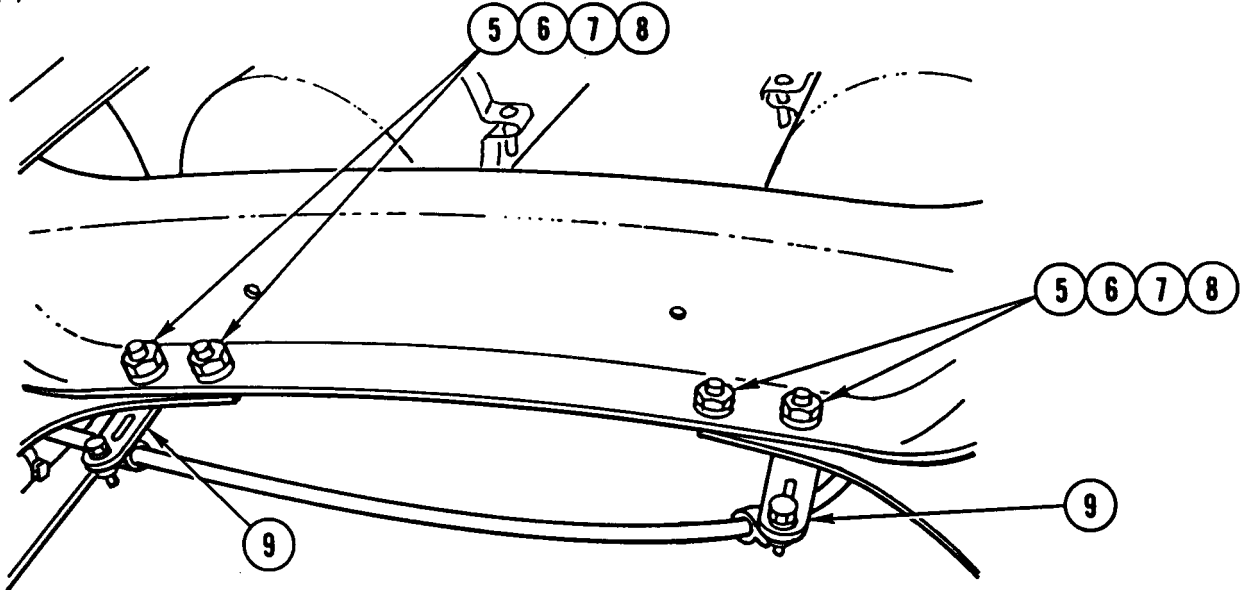

2. REMOVE FOUR NUTS (5), FOUR WASHERS (6), FOUR CAPSCREWS (7), FOUR WASHERS (8), AND TWO BRACKETS (9). SET BRACKETS (9) ASIDE.

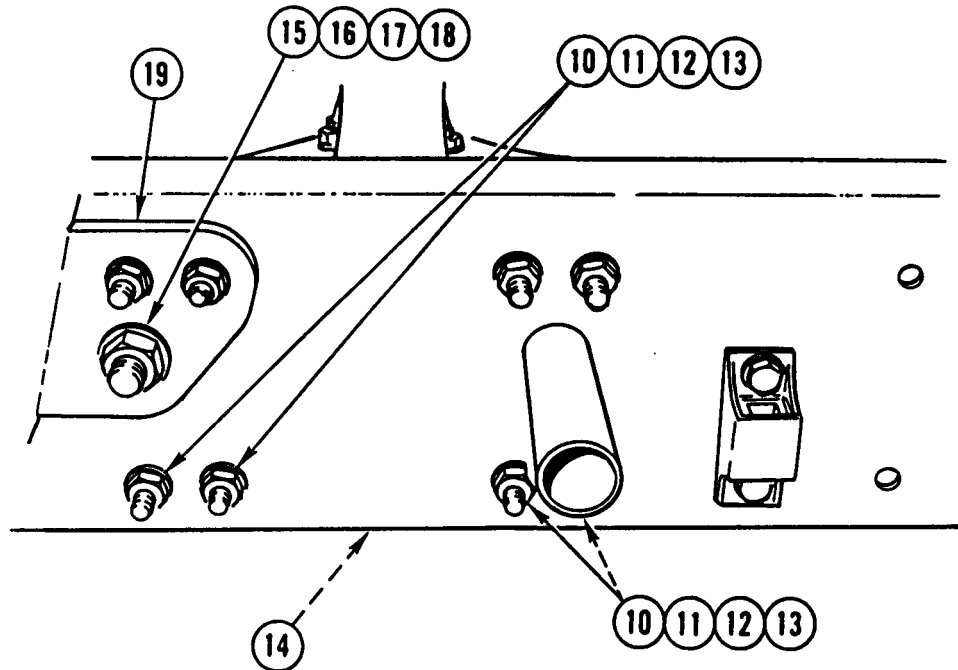

3. REMOVE EIGHT NUTS (10), EIGHT WASHERS (11), EIGHT CAPSCREWS (12), EIGHT WASHERS (13), AND TWO GUSSETS (14).
4. REMOVE NUT (15), WASHER (16), CAPSCREW (17), AND WASHER (18) FROM LIFTING BRACKET (19).

MIDSHIPS ALLIGATOR CROSSMEMBER REPLACEMENT (CONT)

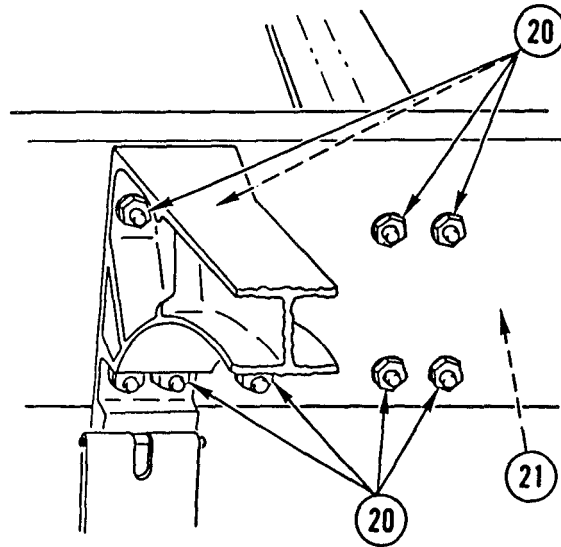

FUEL TANK NOT SHOWN FOR CLARITY

NOTE

Loosen nuts only enough to allow removal of midships alligator crossmember.

5. LOOSEN EIGHT NUTS (20) ON CAB ALLIGATOR CROSSMEMBER (21).

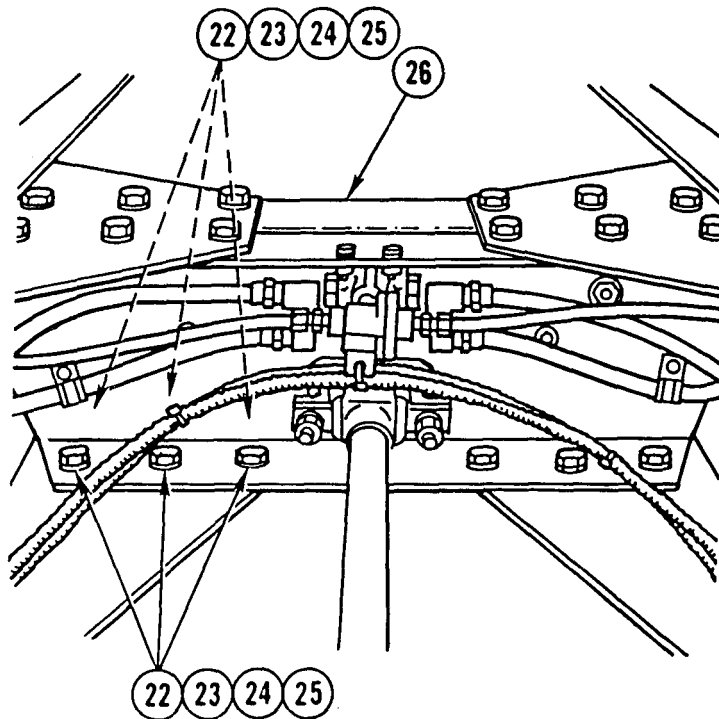

6. REMOVE SIX NUTS (22), SIX WASHERS (23), SIX CAPSCREWS (24), AND SIX WASHERS (25) FROM SUSPENSION CROSSMEMBER (26).

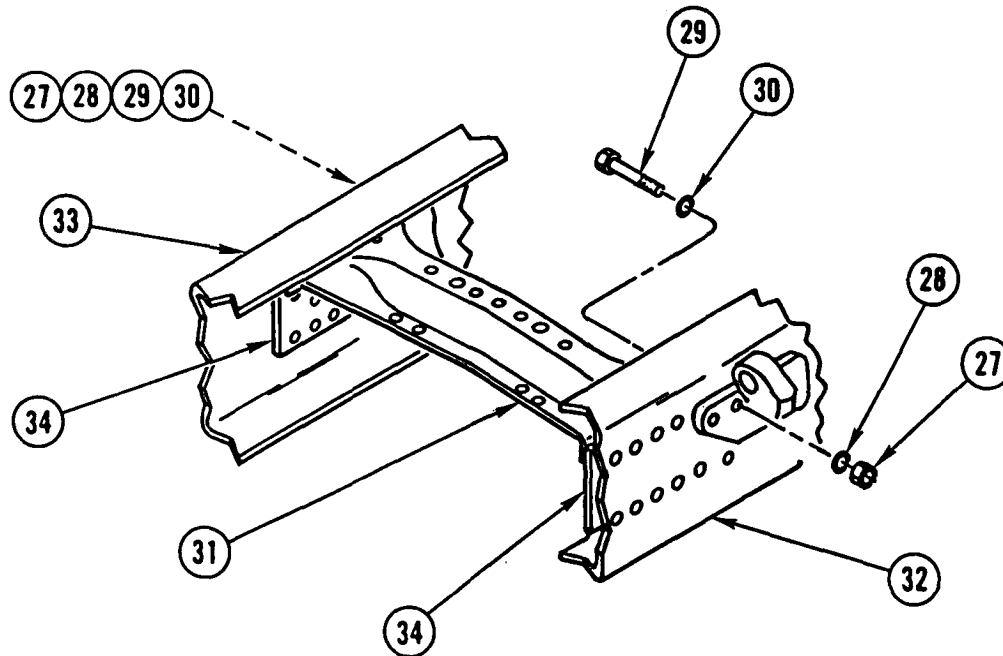

7. REMOVE EIGHT NUTS (27), EIGHT WASHERS (28), EIGHT CAPSCREWS (29), AND EIGHT WASHERS (30) FROM MIDSHIPS ALLIGATOR CROSSMEMBER (31).
8. INSTALL HYDRAULIC SPREADER AT ANGLE GOING FROM INSIDE LOWER CORNER OF LEFT FRAME RAIL (32) TO INSIDE UPPER CORNER OF RIGHT FRAME RAIL (33).

NOTE

It may be necessary to further loosen nuts loosened in step 5 if frame rails will not spread far enough apart to allow removal of midships alligator crossmember.

9. SLOWLY SPREAD TWO FRAME RAILS (32 AND 33) ENOUGH TO ALLOW MIDSHIPS ALLIGATOR CROSSMEMBER (31) TO BE TILTED AT ANGLE OPPOSITE OF HYDRAULIC SPREADER.

CAUTION

To prevent possible damage to frame rails, spread frame rails only enough to allow removal of midships alligator crossmember.

10. CONTINUE TO SPREAD TWO FRAME RAILS (32 AND 33) UNTIL MIDSHIPS ALLIGATOR CROSSMEMBER (31) CAN BE REMOVED.
11. REMOVE MIDSHIPS ALLIGATOR CROSSMEMBER (31) AND TWO SPACERS (34) FROM TWO FRAME RAILS (32 AND 33).

MIDSHIPS ALLIGATOR CROSSMEMBER REPLACEMENT (CONT)

CLEANING

Use general cleaning methods to clean all parts (page 2-30).

INSPECTION

Inspect all parts for wear or damage.

INSTALLATION

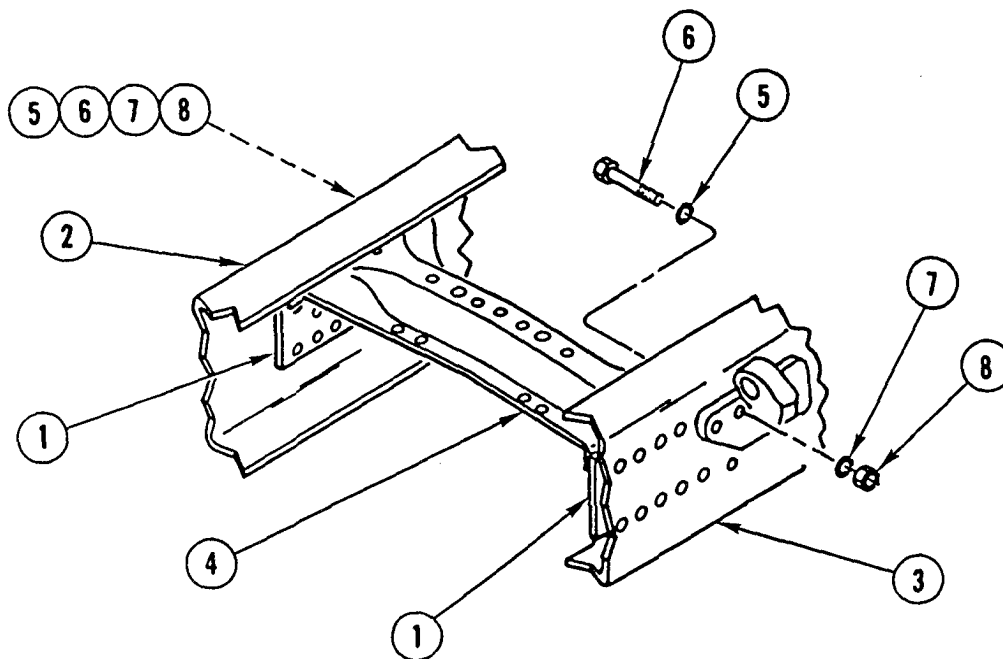

NOTE

Procedure is done on right side of vehicle.

1. INSTALL TWO SPACERS (1) ON TWO FRAME RAILS (2 AND 3).
2. INSTALL MIDSHIPS ALLIGATOR CROSSMEMBER (4) AT ANGLE OPPOSITE OF HYDRAULIC SPREADER BETWEEN TWO FRAME RAILS (2 AND 3).
3. SLOWLY RELEASE PRESSURE ON HYDRAULIC SPREADER, AND AT SAME TIME, KEEP MIDSHIPS ALLIGATOR CROSSMEMBER (4) ALINED WITH TWO FRAME RAILS (2 AND 3).
4. REMOVE HYDRAULIC SPREADER FROM TWO FRAME RAILS (2 AND 3).
5. INSTALL EIGHT WASHERS (5), EIGHT CAPSCREWS (6), EIGHT WASHERS (7), AND EIGHT NUTS (8) ON MIDSHIPS ALLIGATOR CROSSMEMBER AND TWO FRAME RAILS (2 AND 3).

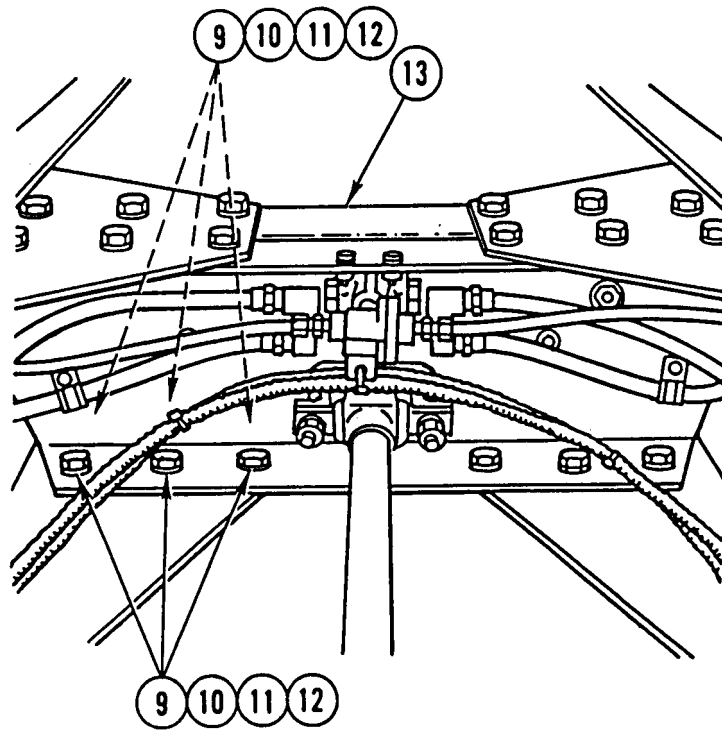

6. INSTALL SIX WASHERS (9), SIX CAPSCREWS (10), SIX WASHERS (11), AND SIX NUTS (12) ON SUSPENSION CROSSMEMBER (13).

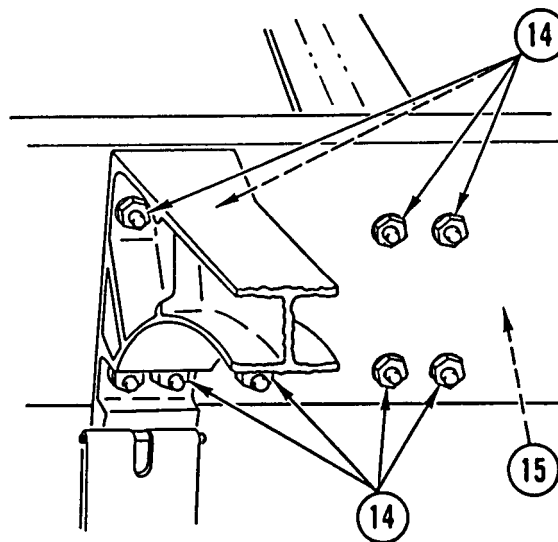

FUEL TANK NOT SHOWN FOR CLARITY

7. TIGHTEN EIGHT NUTS (14) ON CAB ALLIGATOR CROSSMEMBER (15).

MIDSHIPS ALLIGATOR CROSSMEMBER REPLACEMENT (CONT)

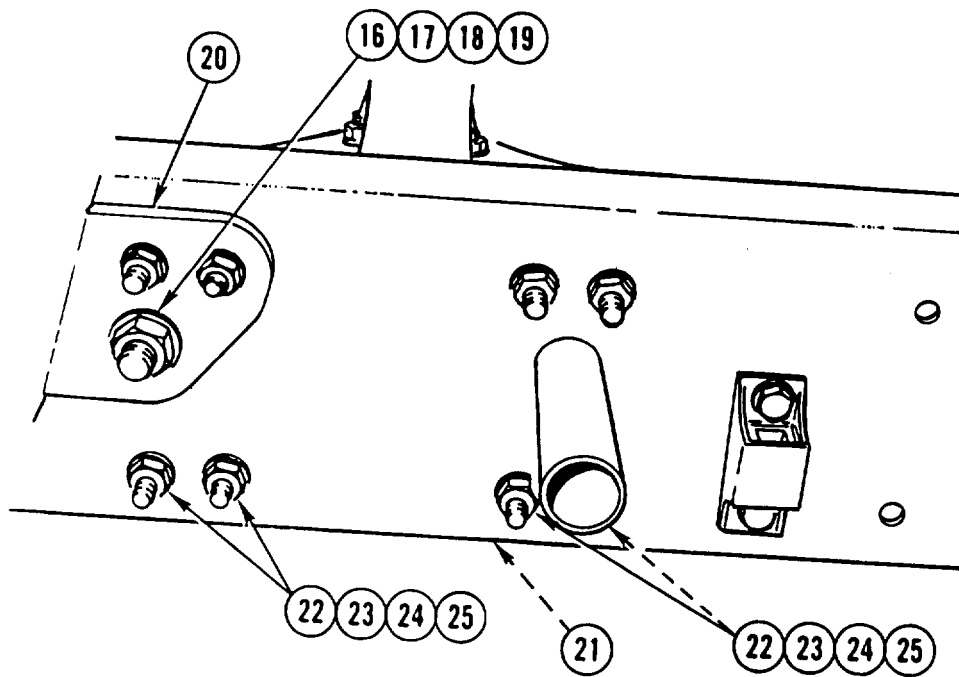

8. INSTALL WASHER (16), CAPSCREW (17), WASHER (18), AND NUT (19) ON LIFTING BRACKET (20).
9. INSTALL TWO GUSSETS (21), EIGHT WASHERS (22), EIGHT CAPSCREWS (23), EIGHT WASHERS (24), AND EIGHT NUTS (25).

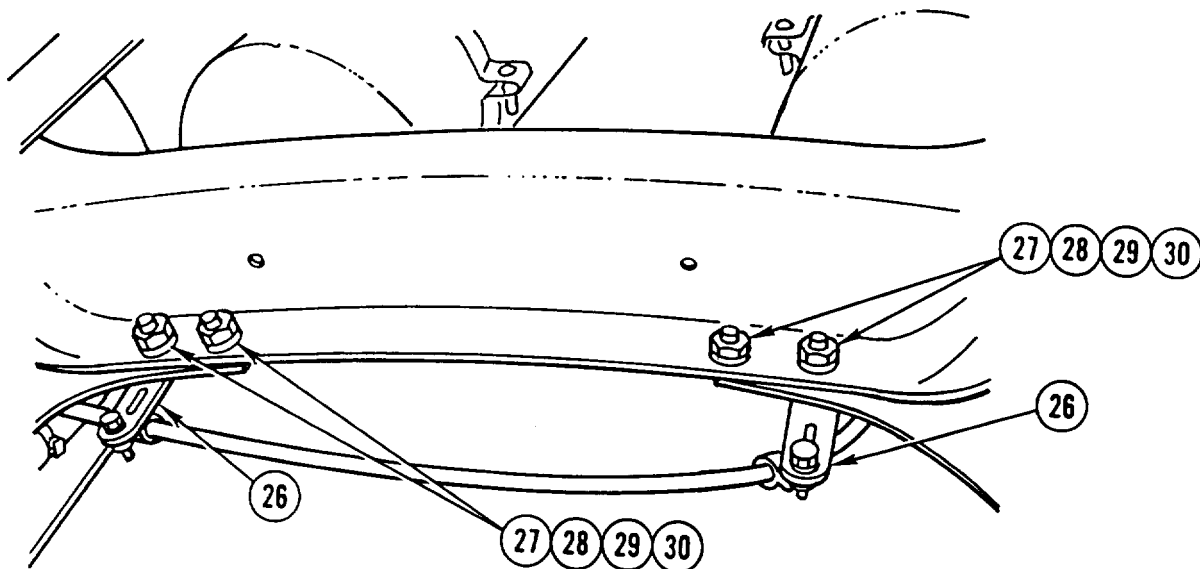

10. INSTALL TWO BRACKETS (26), FOUR WASHERS (27), FOUR CAPSCREWS (28), FOUR WASHERS (29), AND FOUR NUTS (30).

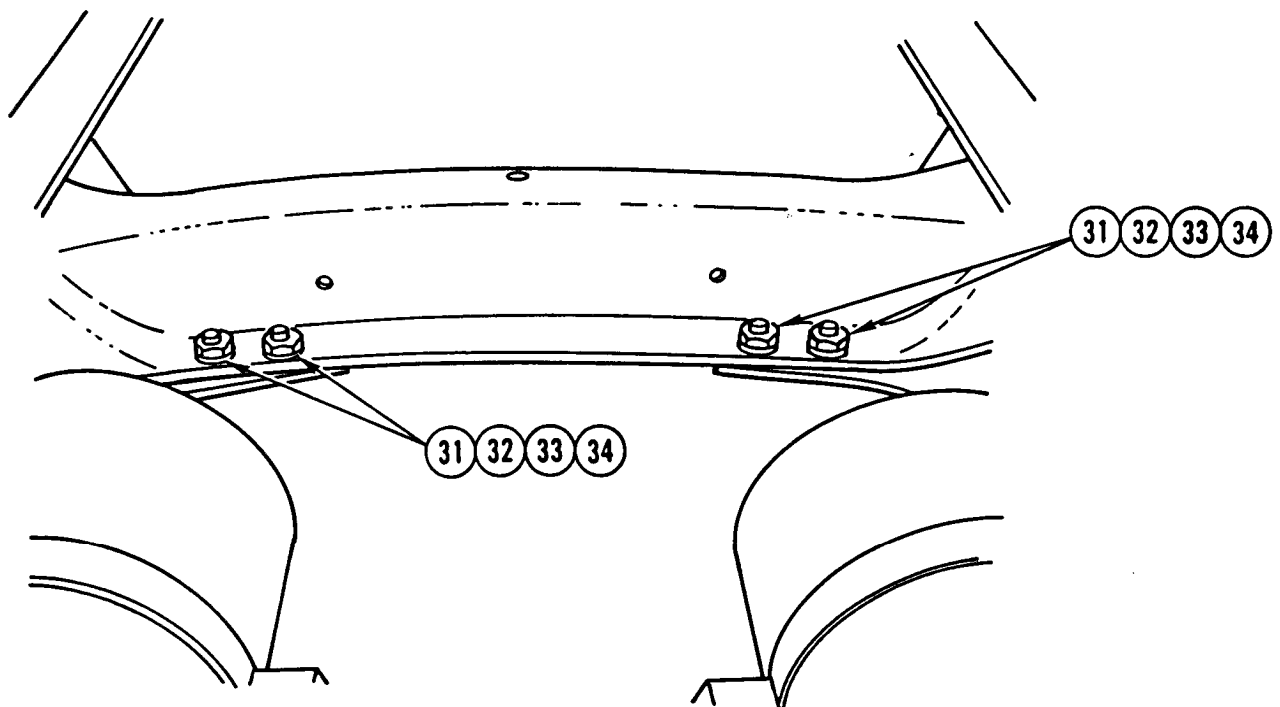

11. INSTALL FOUR WASHERS (31), FOUR CAPSCREWS (32), FOUR WASHERS (33), AND FOUR NUTS (34).

NOTE

Follow-on Maintenance:

- Fill fuel tank (TM 9-2320 -363-10).
- Install rear fender (TM 9-2320-363-20).
- Install hydraulic winch frame (page 11-34).
- Install transfer case (page 3-263).
- Install fifth wheel (page 20-6).
- Install overslung crossmember (page 8-25).
- Install rear crossmember (page 8-20).

REAR SUSPENSION CROSSMEMBER REPLACEMENT

This task covers: a. Removal b. Cleaning c. Inspection d. Installation

INITIAL SETUP

Applicable Configuration:

M915A2

Tools and Special Equipment:

Tool Kit, SC 5180-90-CL-N05

Personnel Required: (2)

References:

TM 9-2320-363-20

Equipment Condition (Cont):

Reference

Condition Description

TM 9-2320-363-20

Rear Quick-Release Valve Removed

Page 20-3

Fifth Wheel Removed

Page 9-8

Rear Spring Hangers Removed

Page 9-14

Torque Rods Removed

Equipment Condition:

Reference

Condition Description

TM 9-2320-363-20

Rear Anti-Lock Brake System (ABS) Air Solenoids Removed

TM 9-2320-363-20

Rear Tractor Protection Valve Removed

TM 9-2320-363-20

Rear Relay Valve Removed

REMOVAL

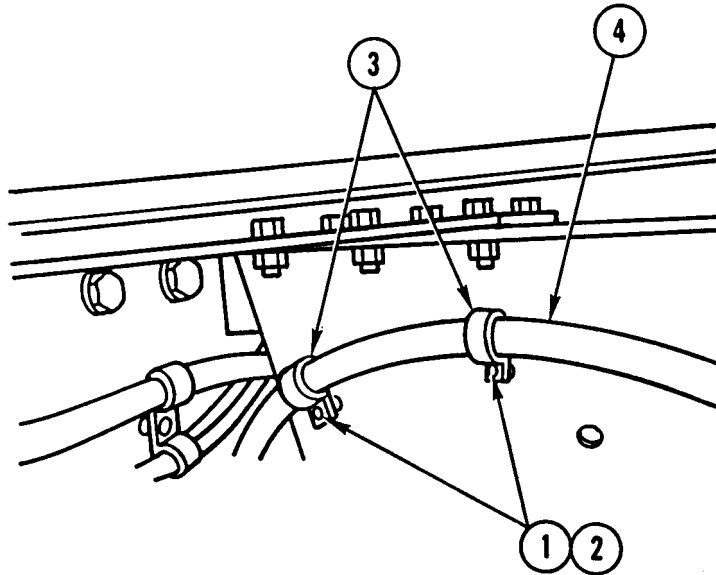

1. REMOVE TWO NUTS (1), TWO WASHERS (2), AND TWO CLAMPS (3) AND SET HOSE (4) ASIDE.

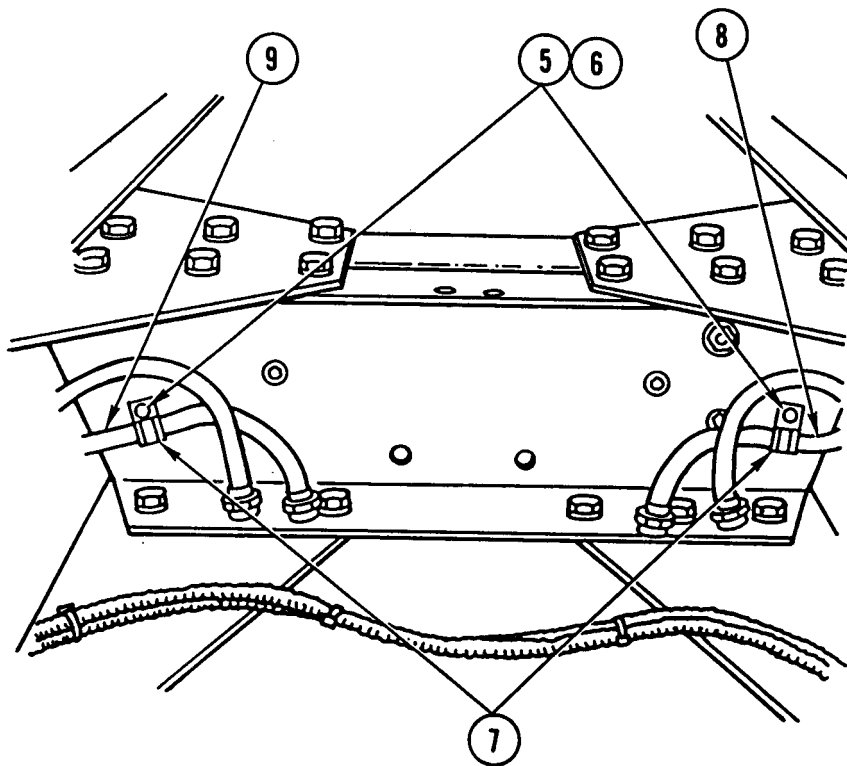

2. REMOVE TWO NUTS (5), TWO WASHERS (6), AND TWO CLAMPS (7) AND SET TWO HOSES (8 AND 9) ASIDE.

REAR SUSPENSION CROSSMEMBER REPLACEMENT (CONT)

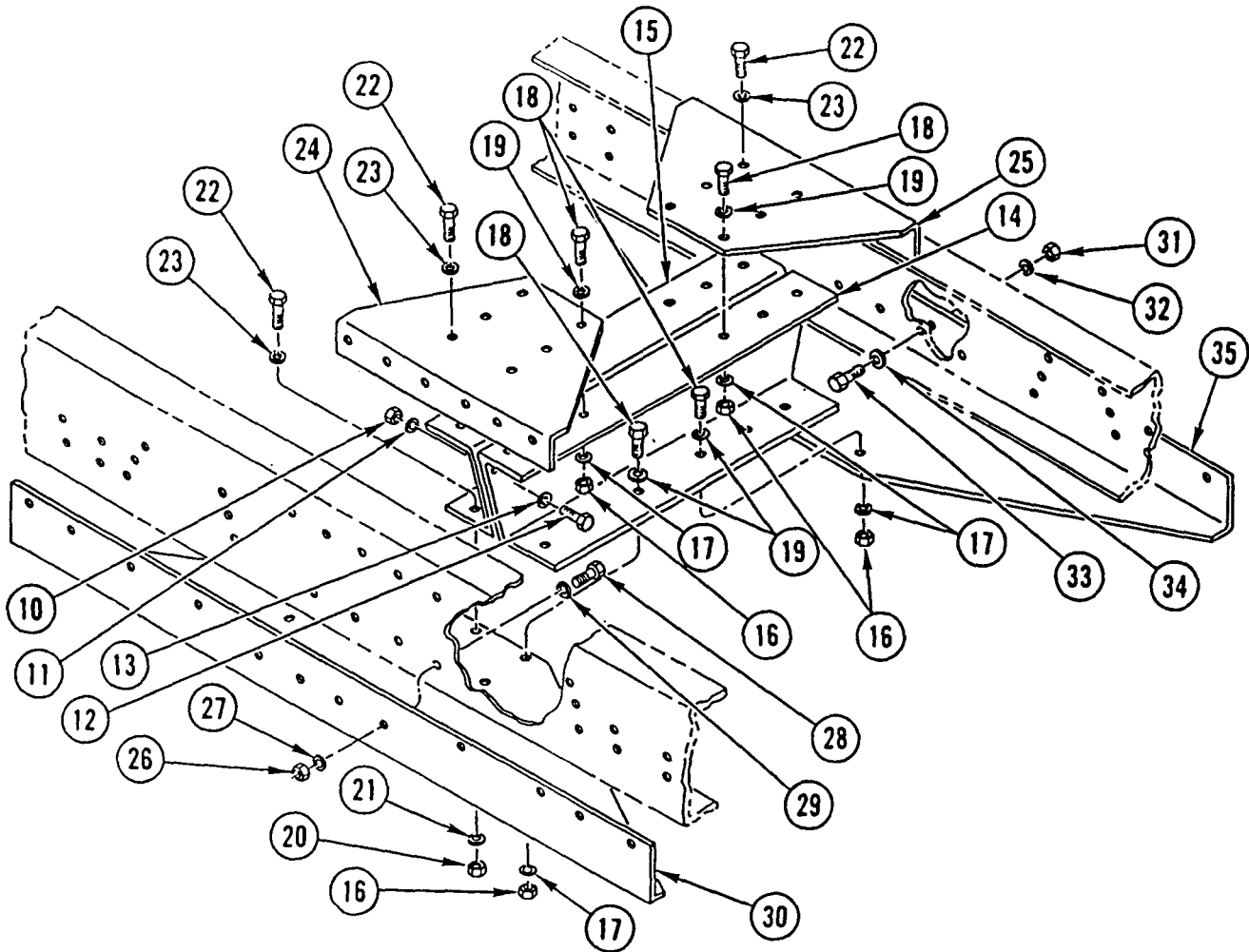

3. REMOVE FOUR NUTS (10), FOUR WASHERS (11), FOUR CAPSCREWS (12), AND FOUR WASHERS (13) FROM TWO REAR SUSPENSION CROSSMEMBERS (14 AND 15).
4. REMOVE 12 NUTS (16), 12 WASHERS (17), 12 CAPSCREWS (18), 12 WASHERS (19), AND REAR SUSPENSION CROSSMEMBER (14).
5. REMOVE 12 NUTS (20), 12 WASHERS (21), 12 CAPSCREWS (22), 12 WASHERS (23), REAR SUSPENSION CROSSMEMBER (15), AND 2 GUSSETS (24 AND 25).

NOTE

Mark left and right gussets prior to removal to aid in installation.

6. REMOVE FOUR NUTS (26), FOUR WASHERS (27), FOUR CAPSCREWS (28), FOUR WASHERS (29), AND LEFT GUSSET (30).
7. REMOVE FOUR NUTS (31), FOUR WASHERS (32), FOUR CAPSCREWS (33), FOUR WASHERS (34), AND RIGHT GUSSET (35).

CLEANING

Use general cleaning methods to clean all parts (page 2-30).

INSPECTION

Inspect all parts for wear or damage.

INSTALLATION

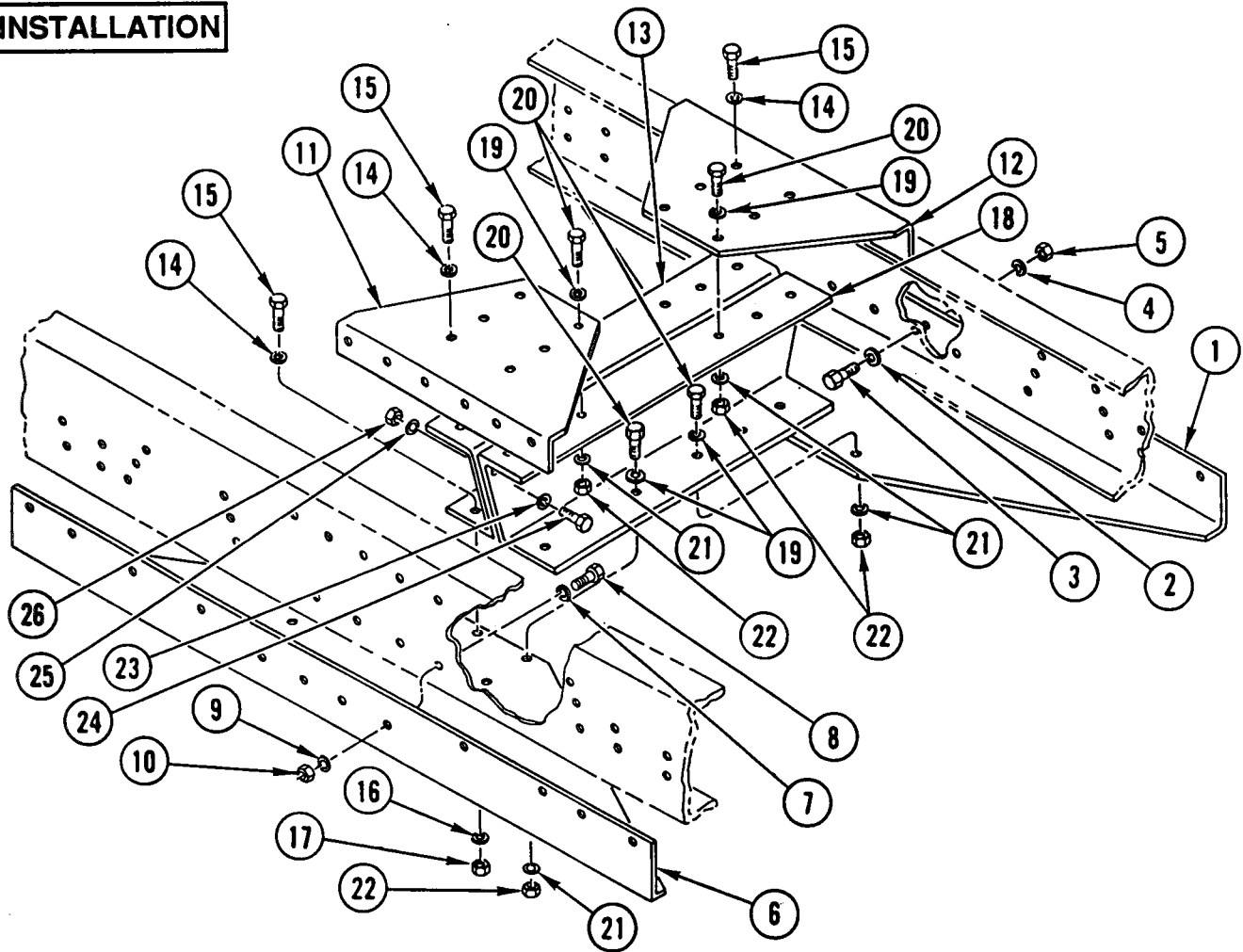

1. INSTALL RIGHT GUSSET (1), FOUR WASHERS (2), FOUR CAPSCREWS (3), FOUR WASHERS (4), AND FOUR NUTS (5).
2. INSTALL LEFT GUSSET (6), FOUR WASHERS (7), FOUR CAPSCREWS (8), FOUR WASHERS (9), AND FOUR NUTS (10).
3. INSTALL 2 GUSSETS (11 AND 12), REAR SUSPENSION CROSSMEMBER (13), 12 WASHERS (14), 12 CAPSCREWS (15), 12 WASHERS (16), AND 12 NUTS (17).
4. INSTALL REAR SUSPENSION CROSSMEMBER (18), 12 WASHERS (19), 12 CAPSCREWS (20), 12 WASHERS (21), AND 12 NUTS (22).
5. INSTALL FOUR WASHERS (23), FOUR CAPSCREWS (24), FOUR WASHERS (25), AND FOUR NUTS (26) ON TWO REAR SUSPENSION CROSSMEMBERS (13 AND 18).

REAR SUSPENSION CROSSMEMBER REPLACEMENT (CONT)

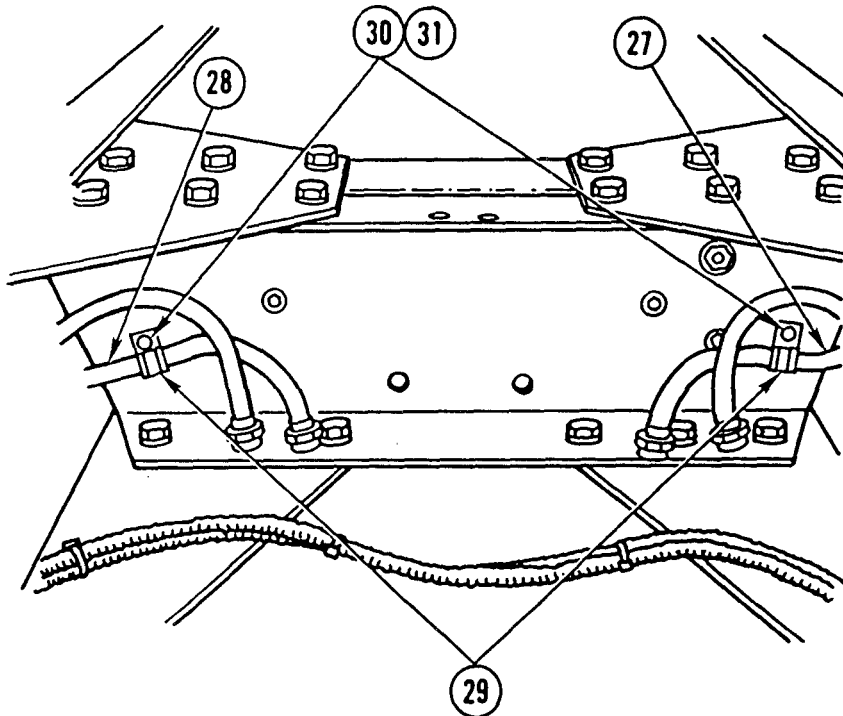

6. POSITION TWO HOSES (27 AND 28) AND INSTALL TWO CLAMPS (29), TWO WASHERS (30), AND TWO NUTS (31).

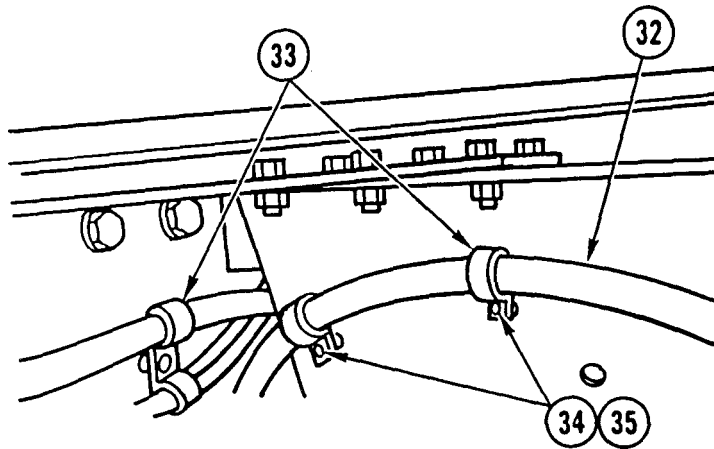

7. POSITION HOSE (32) AND INSTALL TWO CLAMPS (33), TWO WASHERS (34), AND TWO NUTS (35).

NOTE

Follow-on Maintenance:
Install rear tractor protection valve (TM 9-2320-363-20).
Install rear relay valve (TM 9-2320-363-20).
Install rear quick-release valve (TM 9-2320-363-20).
Install fifth wheel (page 20-3).
Install rear spring hangers (page 9-8).
Install torque rods (page 9-14).
Install rear Anti-Lock Brake System (ABS) air solenoids (TM 9-2320-363-20).

REAR SUSPENSION CROSSMEMBER REPLACEMENT

This task covers: a. Removal b. Cleaning c. Inspection d. Installation

INITIAL SETUP

Applicable Configuration:

All except M915A2

Tools and Special Equipment:

Tool Kit, SC 5180-90-CL-N05

Personnel Required: (2)

References:

TM 9-2320-363-20

Equipment Condition:

Reference

TM 9-2320-363-20

TM 9-2320-363-20

Page 20-6

Page 9-14

Condition Description

Rear Relay Valve
Removed

Rear Quick-Release
Valve Removed

Fifth Wheel Removed

Torque Rods Removed

REMOVAL

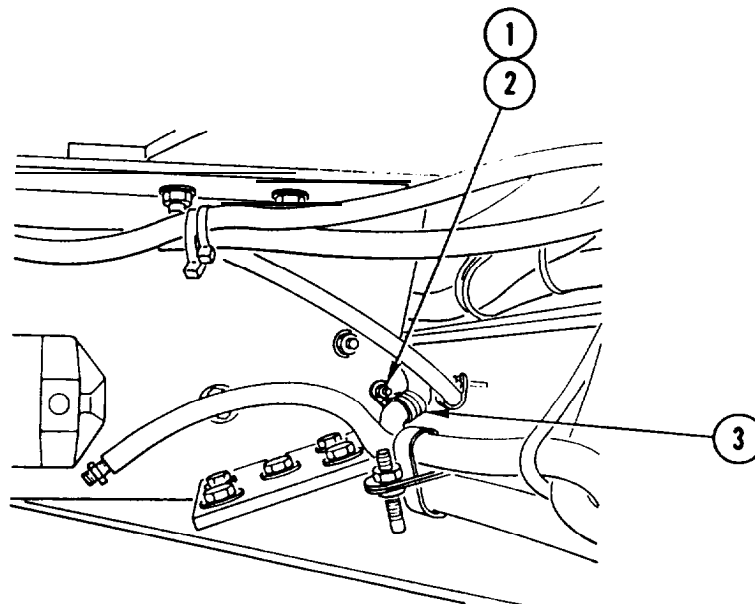

NOTE

Step 1 is for right side only.

1. REMOVE NUT (1) WASHER (2) AND CLAMP (3).

REAR SUSPENSION CROSSMEMBER REPLACEMENT (CONT)

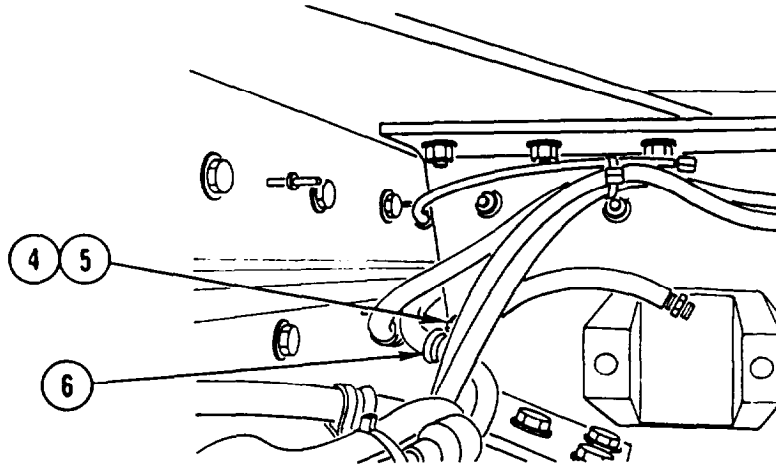

NOTE

Step 2 is for left side only.

2. REMOVE NUT (4), WASHER (5), AND CLAMP (6).

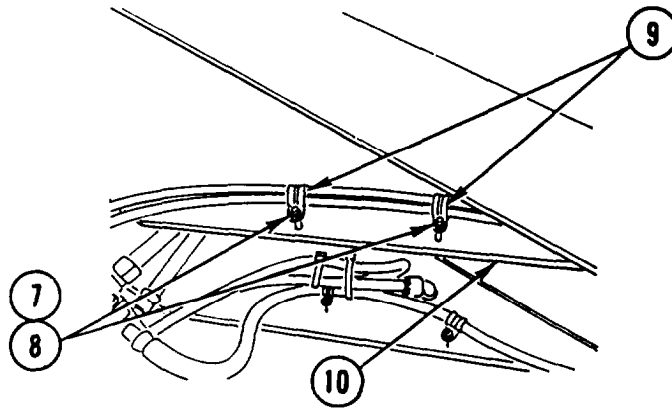

3. REMOVE TWO NUTS (7), TWO WASHERS (8), AND TWO CLAMPS (9) FROM TOP RIGHT GUSSET (10).

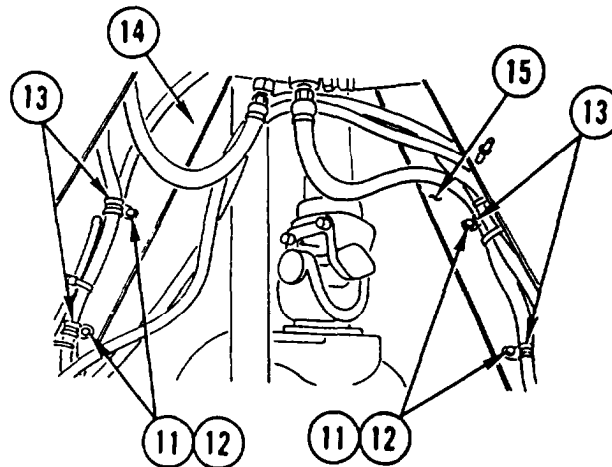

- REMOVE FOUR NUTS (11), FOUR WASHERS (12), AND EIGHT CLAMPS (13), FROM TWO LOWER GUSSETS (14 AND 15).

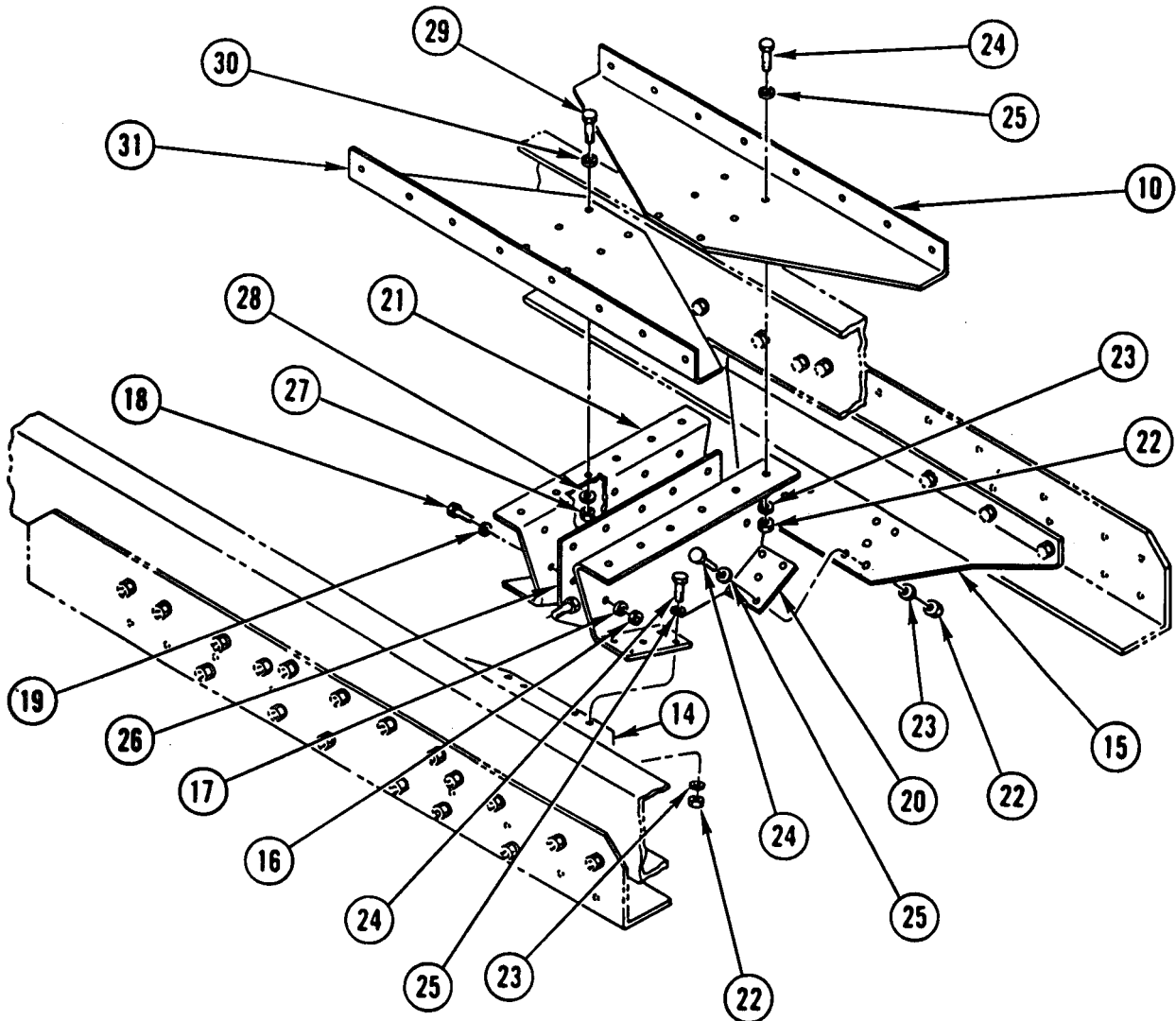

- REMOVE SEVEN NUTS (16), SEVEN WASHERS (17), SEVEN CAPSCREWS (18), AND SEVEN WASHERS (19) FROM REAR SUSPENSION CROSSMEMBERS (20 AND 21).
- REMOVE 16 NUTS (22), 16 WASHERS (23), 16 CAPSCREWS (24), 16 WASHERS (25), REAR SUSPENSION CROSSMEMBER (20), AND CROSSMEMBER BACKING PLATE (26).

NOTE

Mark left and right gussets prior to removal to aid in installation.

- REMOVE 16 NUTS (27), 16 WASHERS (28), 16 CAPSCREWS (29) 16 WASHERS (30), REAR SUSPENSION CROSSMEMBER (21), AND 2 GUSSETS (10 AND 31).

REAR SUSPENSION CROSSMEMBER REPLACEMENT (CONT)

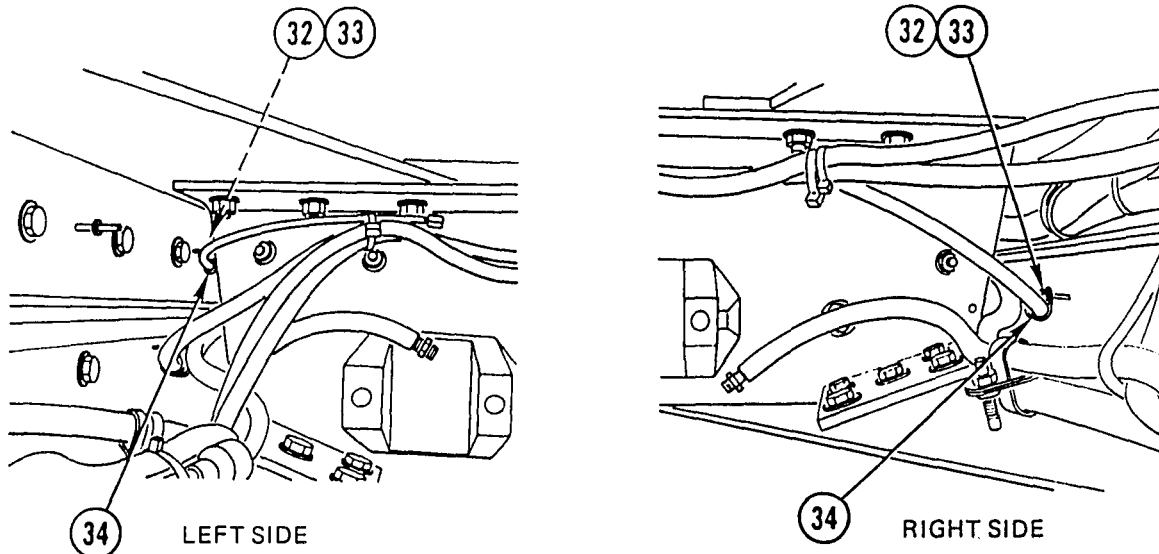

8. REMOVE TWO NUTS (32), TWO WASHERS (33), AND TWO CLAMPS (34).

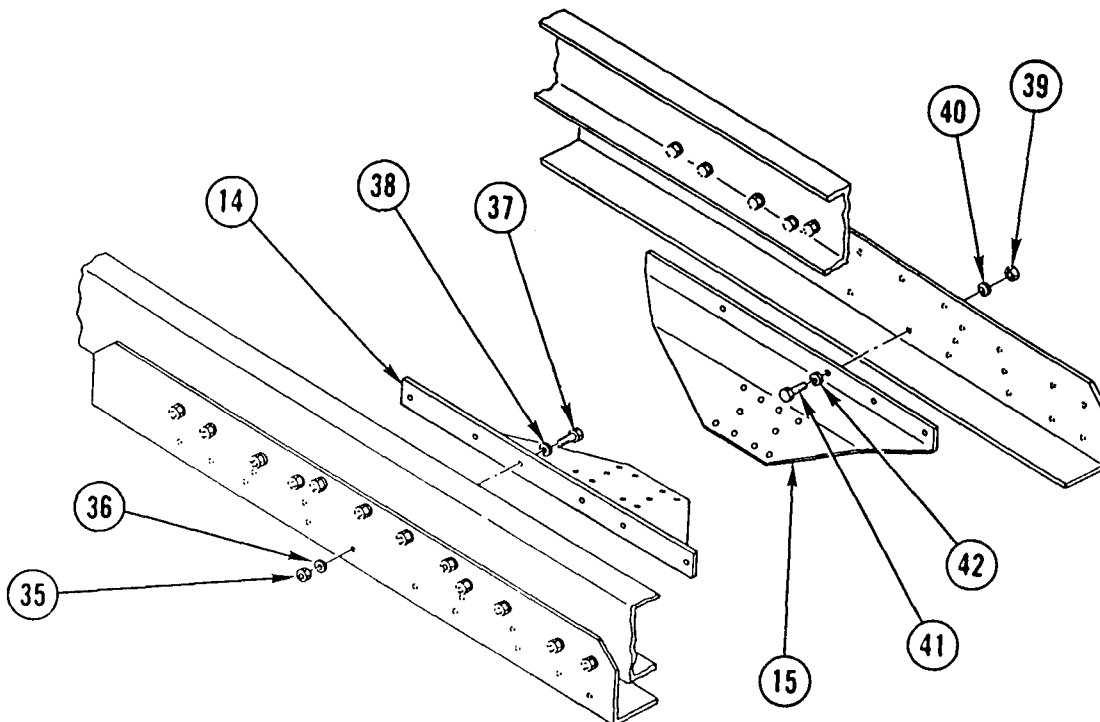

NOTE

Mark left and right gussets prior to removal to aid in installation.

9. REMOVE SIX NUTS (35), SIX WASHERS (36), SIX CAPSCREWS (37), SIX WASHERS (38), AND LOWER LEFT GUSSET (14).
10. REMOVE SIX NUTS (39), SIX WASHERS (40), SIX CAPSCREWS (41), SIX WASHERS (42), AND LOWER RIGHT GUSSET (15).

CLEANING

Use general cleaning methods to clean all parts (page 2-30).

INSPECTION

Inspect all pans for wear or damage.

INSTALLATION

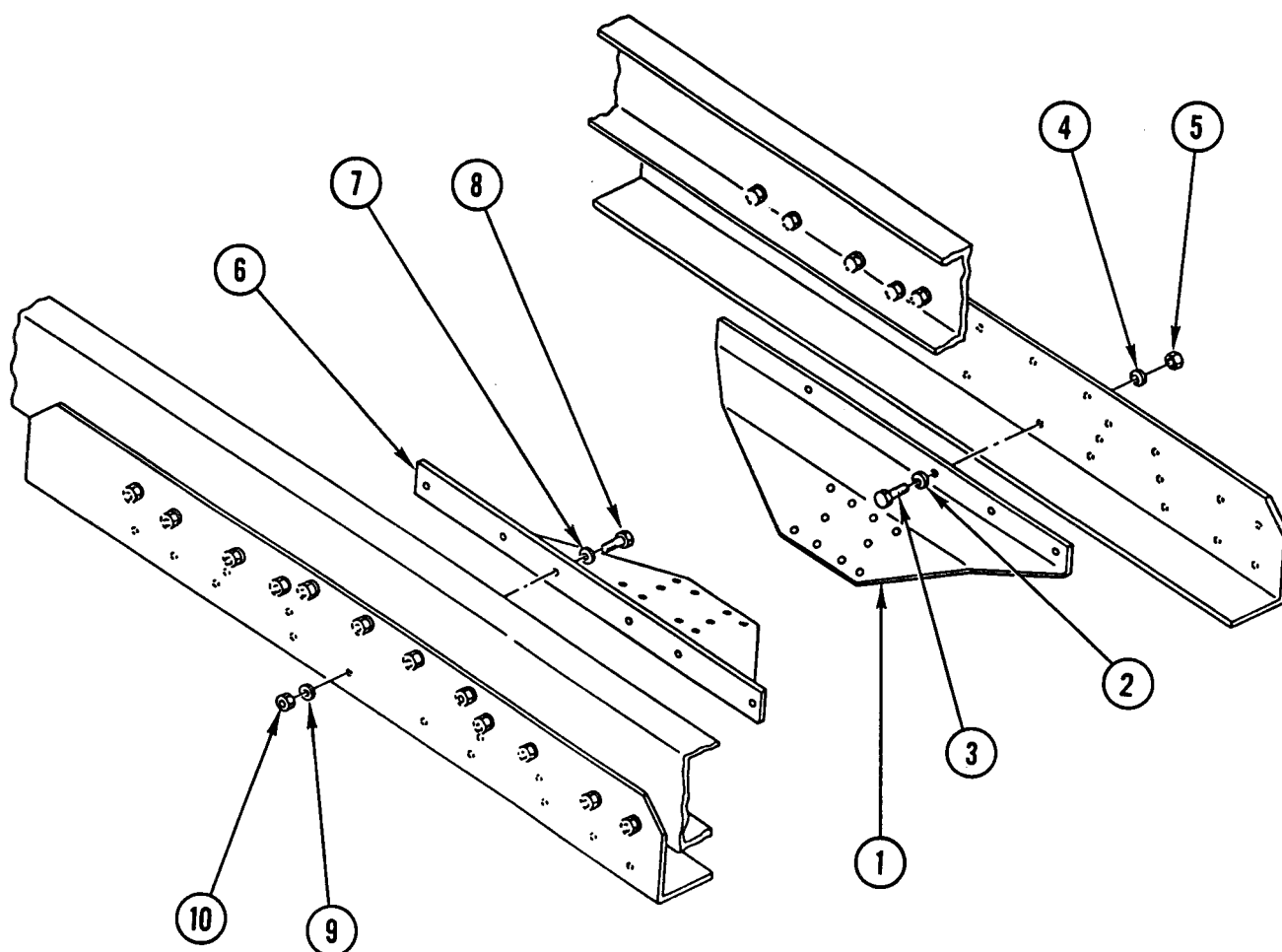

1. INSTALL LOWER RIGHT GUSSET (1), SIX WASHERS (2), SIX CAPSCREWS (3), SIX WASHERS (4), AND SIX NUTS (5).
2. INSTALL LOWER LEFT GUSSET (6), SIX WASHERS (7), SIX CAPSCREWS (8), SIX WASHERS (9), AND SIX NUTS (10).

REAR SUSPENSION CROSSMEMBER REPLACEMENT (CONT)

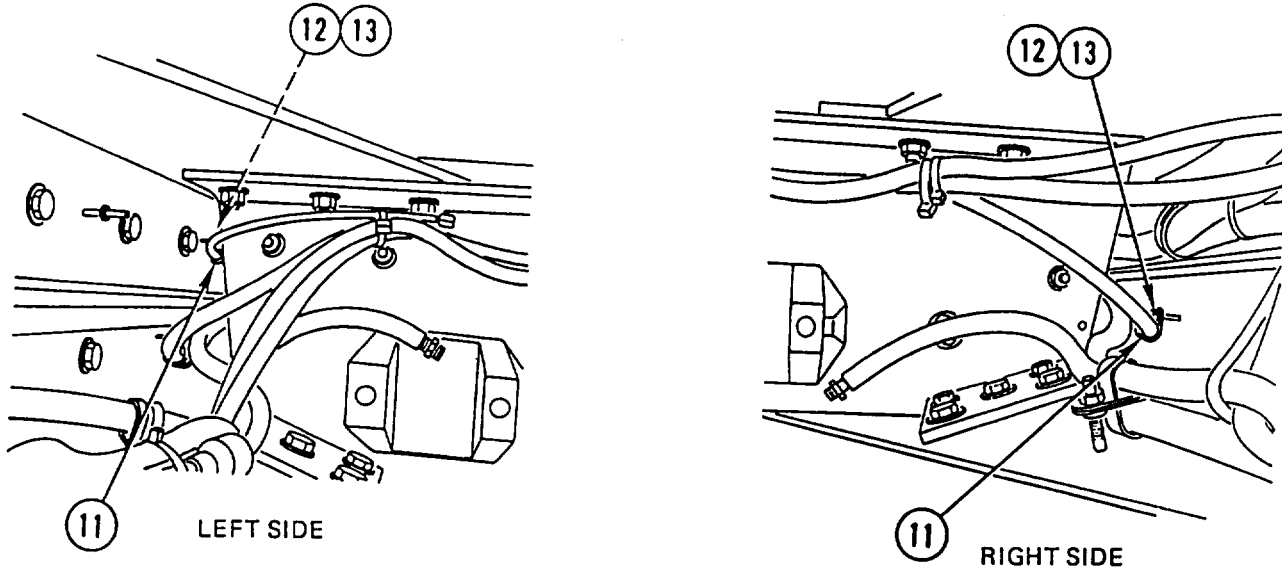

3. INSTALL TWO CLAMPS (11), TWO WASHERS (12), AND TWO NUTS (13).

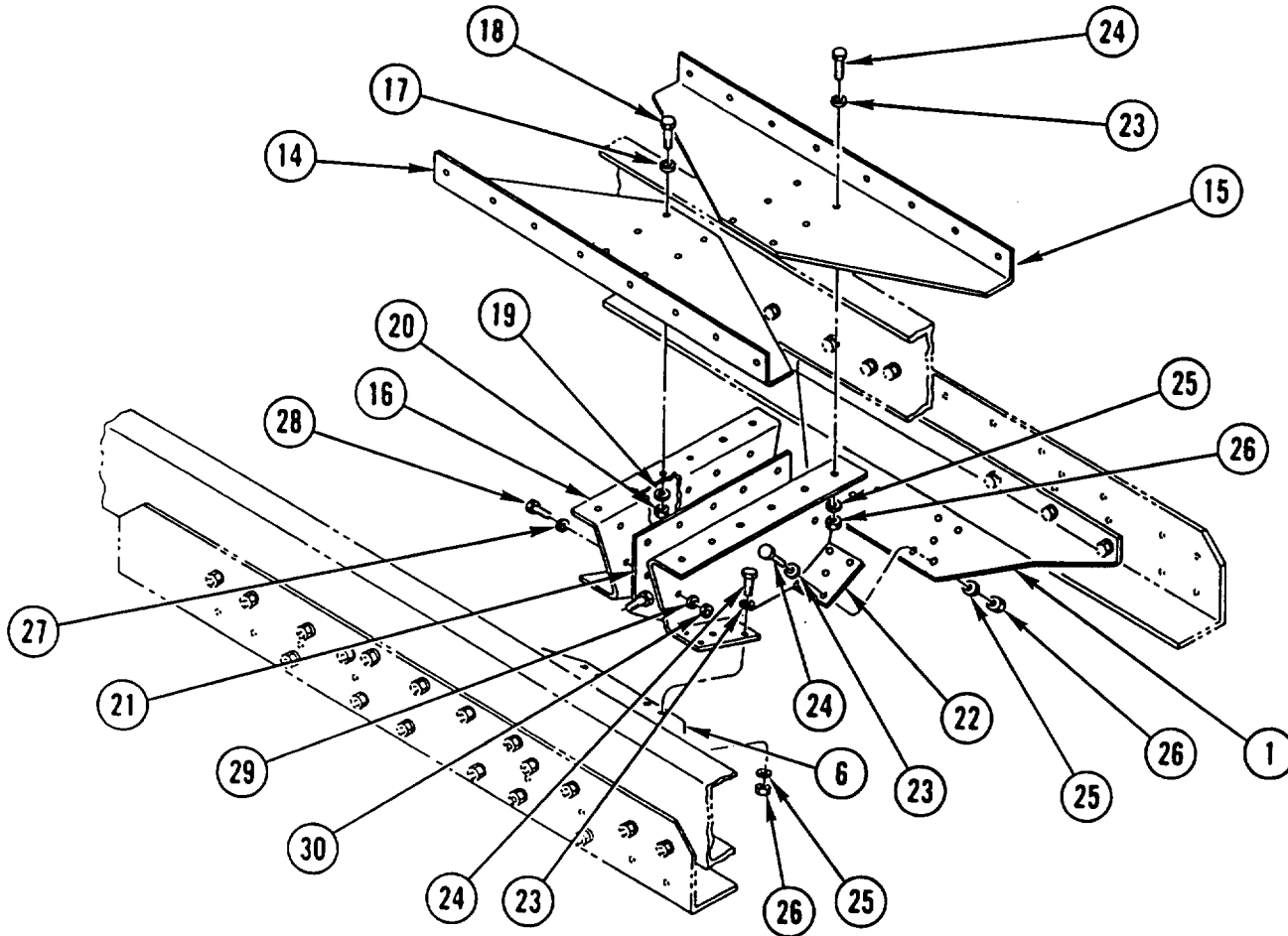

4. INSTALL 2 GUSSETS (14 AND 15), REAR SUSPENSION CROSSMEMBER (16), 16 WASHERS (17), 16 CAPSCREWS (18), 16 WASHERS (19), AND 16 NUTS (20).

5. INSTALL CROSSMEMBER BACKING PLATE (21), REAR SUSPENSION CROSSMEMBER (22), 16 WASHERS (23), 16 CAPSCREWS (24), 16 WASHERS (25), AND 16 NUTS (26).
6. INSTALL SEVEN WASHERS (27), SEVEN CAPSCREWS (28), SEVEN WASHERS (29), AND SEVEN NUTS (30) ON REAR SUSPENSION CROSSMEMBERS (16 AND 22).

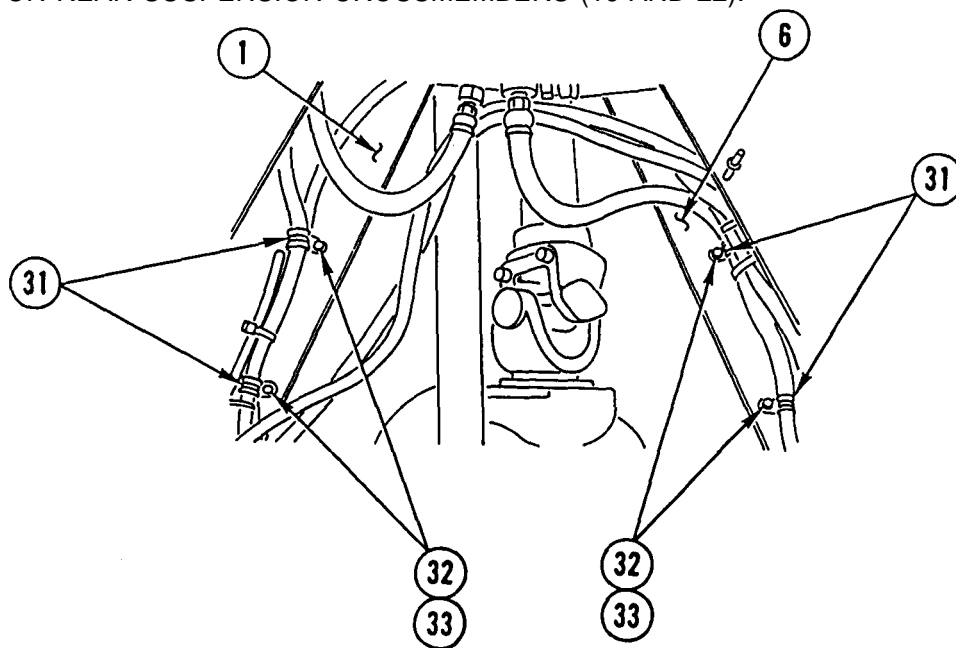

7. INSTALL EIGHT CLAMPS (31), FOUR WASHERS (32), AND FOUR NUTS (33) ON TWO LOWER GUSSETS (1 AND 6).

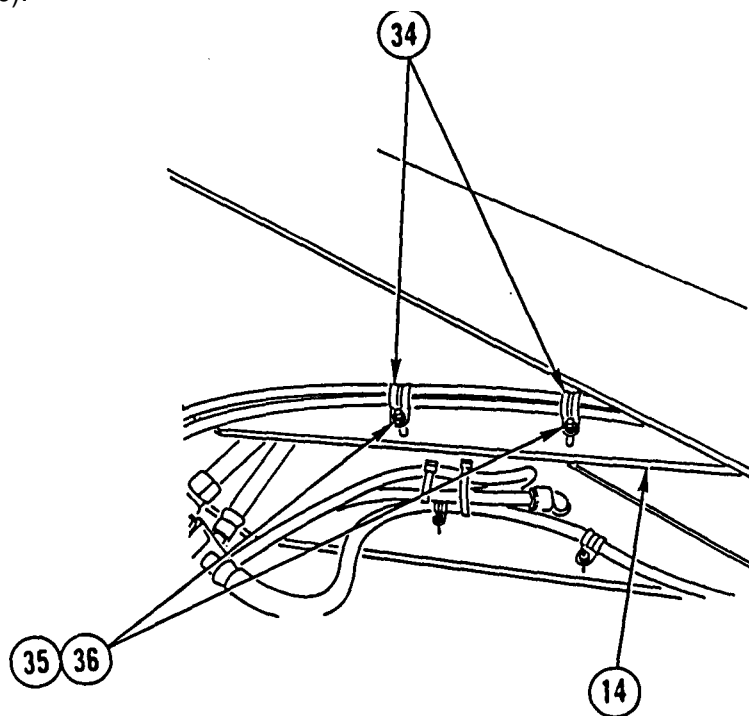

8. INSTALL TWO CLAMPS (34), TWO WASHERS (35), AND TWO NUTS (36) ON TOP RIGHT GUSSET (14).

REAR SUSPENSION CROSSMEMBER REPLACEMENT (CONT)

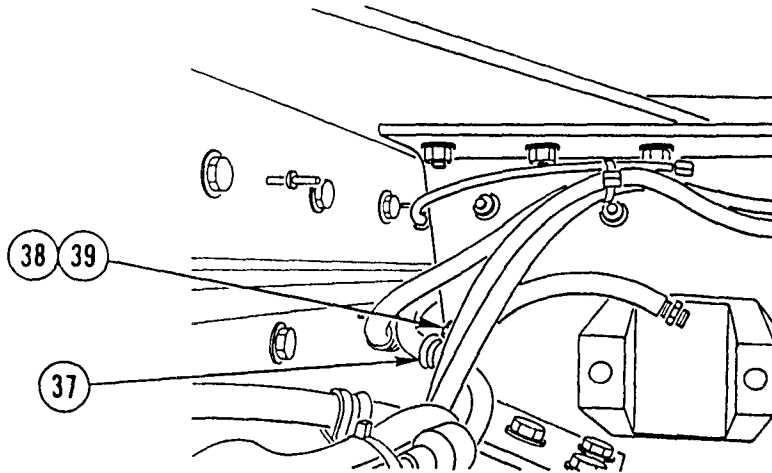

NOTE

Step 9 is for left side only.

9. INSTALL CLAMP (37), WASHER (38), AND NUT (39).

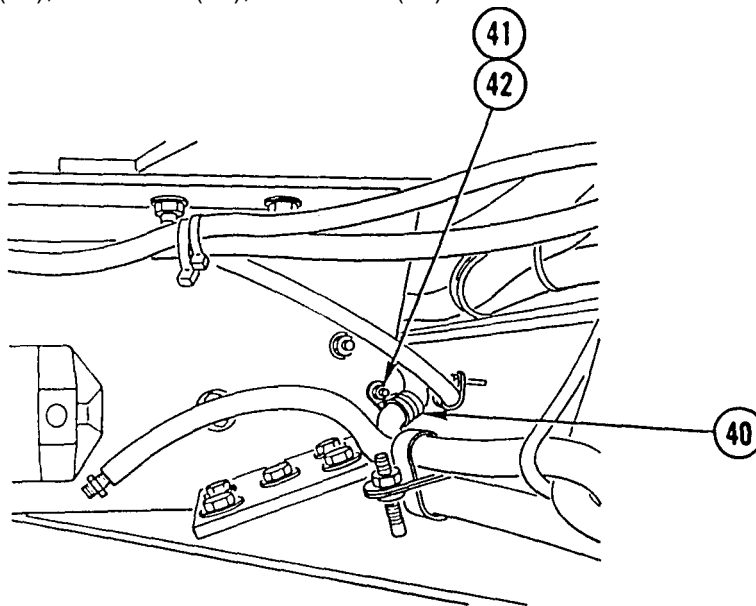

NOTE

Step 10 is for right side only.

10. INSTALL CLAMP (40), WASHER (41), AND NUT (42).

NOTE

Follow-on Maintenance:

- Install rear relay valve (TM 9-2320-363-20).
- Install rear quick-release valve (TM 9-2320-363-20).
- Install fifth wheel (page 20-6).
- Install torque rods (page 9-14).

CHAPTER 9 SUSPENSION MAINTENANCE

OVERVIEW

This chapter illustrates and describes procedures for maintenance of the suspension and related parts. A list of tasks contained in this chapter is shown below.

	Page
Front Spring Replacement	9-2
Front Spring Hangers Replacement	9-8
Rear Spring and Saddle Assembly Replacement	9-12
Torque Rod Replacement	9-14
Rear Spring Hanger Replacement	9-18
Equalizing Beam Replacement (M915A2)	9-22
Equalizing Beam Replacement (All Except M915A2)	9-28

FRONT SPRING REPLACEMENT

This task covers: a. Removal b. Cleaning c. Inspection d. Installation

INITIAL SETUP

Tools and Special Equipment:

Shop Equipment, SC 4910-95-CL-A31
Tool Kit, SC 5180-90-CL-N05

References:

TM 9-2320-363-10

Equipment Condition:

Reference	Condition	Description
TM 9-2320-363-10	Front Wheel	Removed

General Safety Instructions:

WARNING
Shim(s) is used to adjust
caster alignment. Failure to
install shim(s) correctly will
cause hard steering, and could
result in injury to personnel.

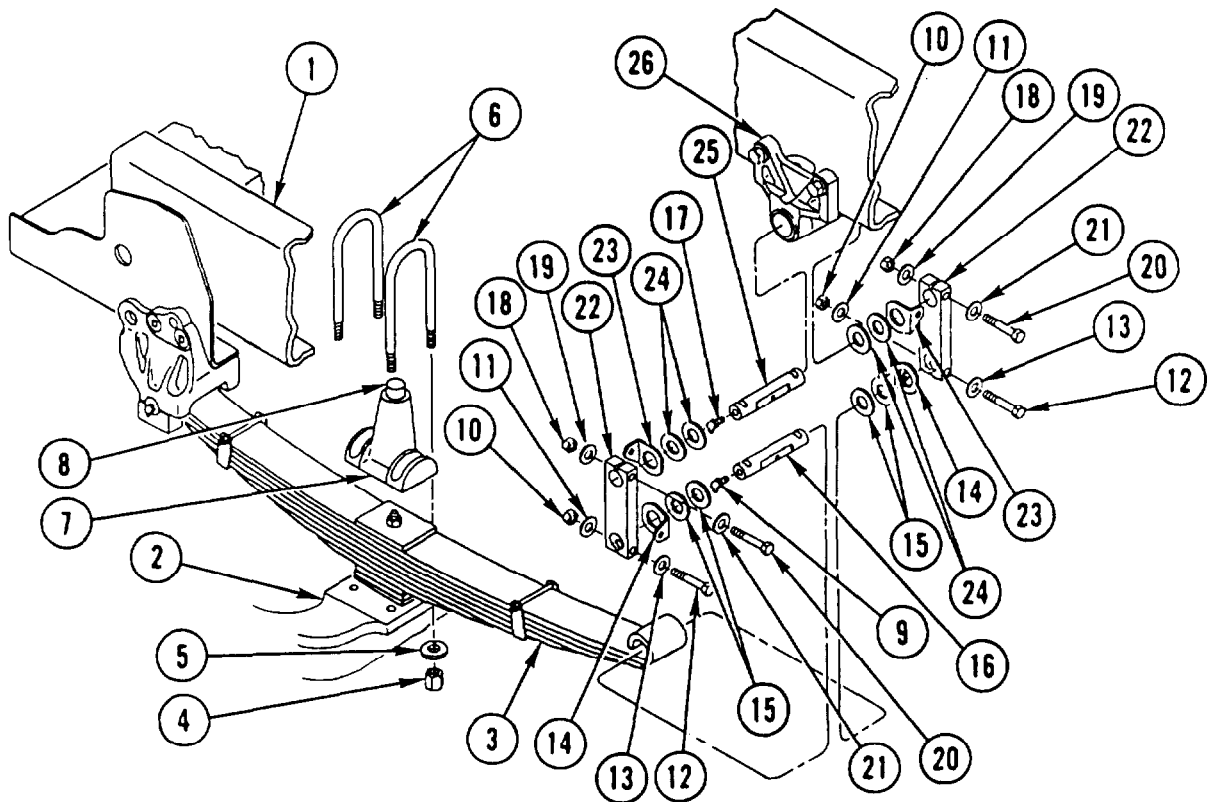
REMOVAL**NOTE**

Procedure is the same for all vehicles except as noted. M915A2 is shown.

1. USING SUITABLE LIFTING DEVICE, LIFT AND SUPPORT FRAME (1) AND FRONT AXLE (2) TO RELIEVE WEIGHT FROM SPRING (3).

NOTE

Axle stop is offset to one side to align with frame. Note position of axle stop prior to removal to aid in installation.

2. REMOVE FOUR NUTS (4), FOUR WASHERS (5), TWO U-BOLTS (6), AND AXLE STOP (7) FROM FRONT AXLE (2) AND SPRING (3).
3. REMOVE STOP CUSHION (8) FROM AXLE STOP (7).
4. REMOVE GREASE FITTING (9), TWO NUTS (10), TWO WASHERS (11), TWO SCREWS (12), TWO WASHERS (13), TWO WEAR PLATES (14), FOUR SHIMS (15), AND PIN (16) FROM REAR END OF SPRING (3).
5. REMOVE GREASE FITTING (17), TWO NUTS (18), TWO WASHERS (19), TWO SCREWS (20), TWO WASHERS (21), TWO SHACKLES (22), TWO WEAR PLATES (23), FOUR SHIMS (24), AND PIN (25) FROM REAR SPRING HANGER (26).

FRONT SPRING REPLACEMENT (CONT)

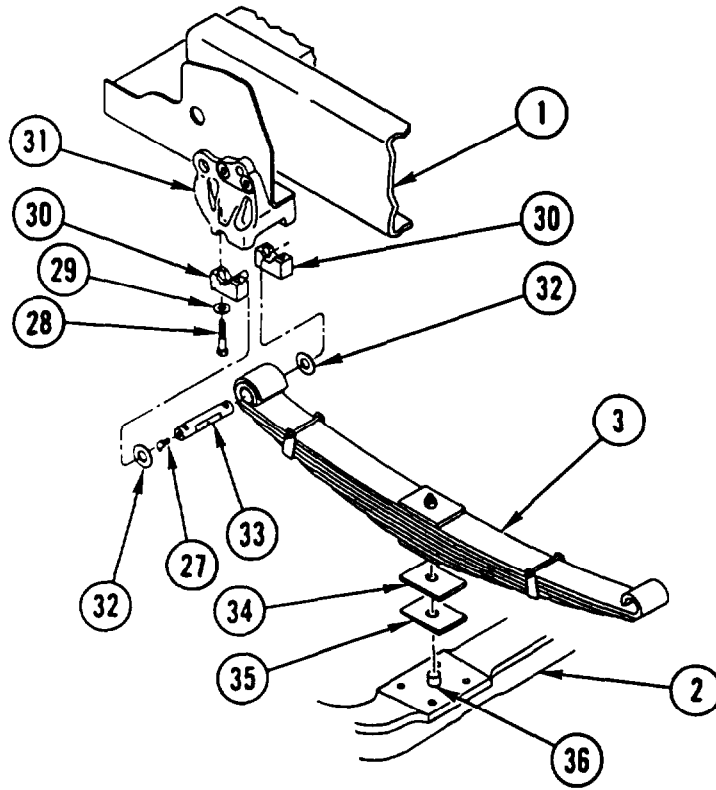

6. REMOVE GREASE FITTING (27), FOUR SCREWS (28), FOUR WASHERS (29), AND TWO SADDLE CAPS (30).
7. LOWER FRONT AXLE (2) TO ALLOW SPRING (3) TO CLEAR FRONT SPRING HANGER (31). REMOVE TWO WASHERS (32) AND PIN (33) FROM FRONT OF SPRING (3).

NOTE

- Note position and number of shim(s) prior to removal to aid in installation.
- Perform step 8 on M915A2 only.

8. REMOVE SPRING (3), SPACER (34), SHIM(S) (35), AND PIN (36).

NOTE

Perform step 9 on all except M915A2.

9. REMOVE SPRING (3) FROM FRONT AXLE (2).

CLEANING

Use general cleaning methods to clean all parts (page 2-30).

INSPECTION

Inspect all parts for wear or damage.

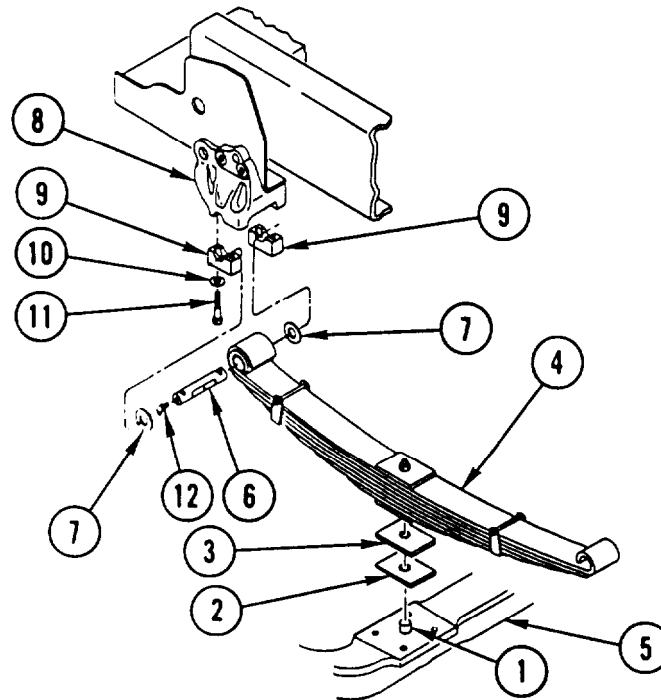
INSTALLATION**WARNING**

Shim(s) is used to adjust caster alignment. Failure to install shim(s) correctly will cause hard steering, and could result in injury to personnel.

NOTE

- Procedure is the same for all vehicles except as noted. M915A2 is shown.
- Perform step 1 on M915A2 only.

1. INSTALL PIN (1), SHIM(S) (2), SPACER (3), AND SPRING (4) ON FRONT AXLE (5).

NOTE

Perform step 2 on all except M915A2.

2. INSTALL SPRING (4) ON FRONT AXLE (5).

NOTE

Install pin so that grooves line up with holes in shackle, allowing screws to be installed.

3. INSTALL PIN (6) AND TWO WASHERS (7) IN SPRING (4).
4. USING SUITABLE LIFTING DEVICE, RAISE FRONT AXLE (5) SO THAT FRONT END OF SPRING (4) IS POSITIONED IN FRONT SPRING HANGER (8). INSTALL TWO SADDLE CAPS (9), FOUR WASHERS (10), FOUR SCREWS (11), AND GREASE FITTING (12). TIGHTEN SCREWS TO 50 LB-FT (68 N.m).

FRONT SPRING REPLACEMENT (CONT)

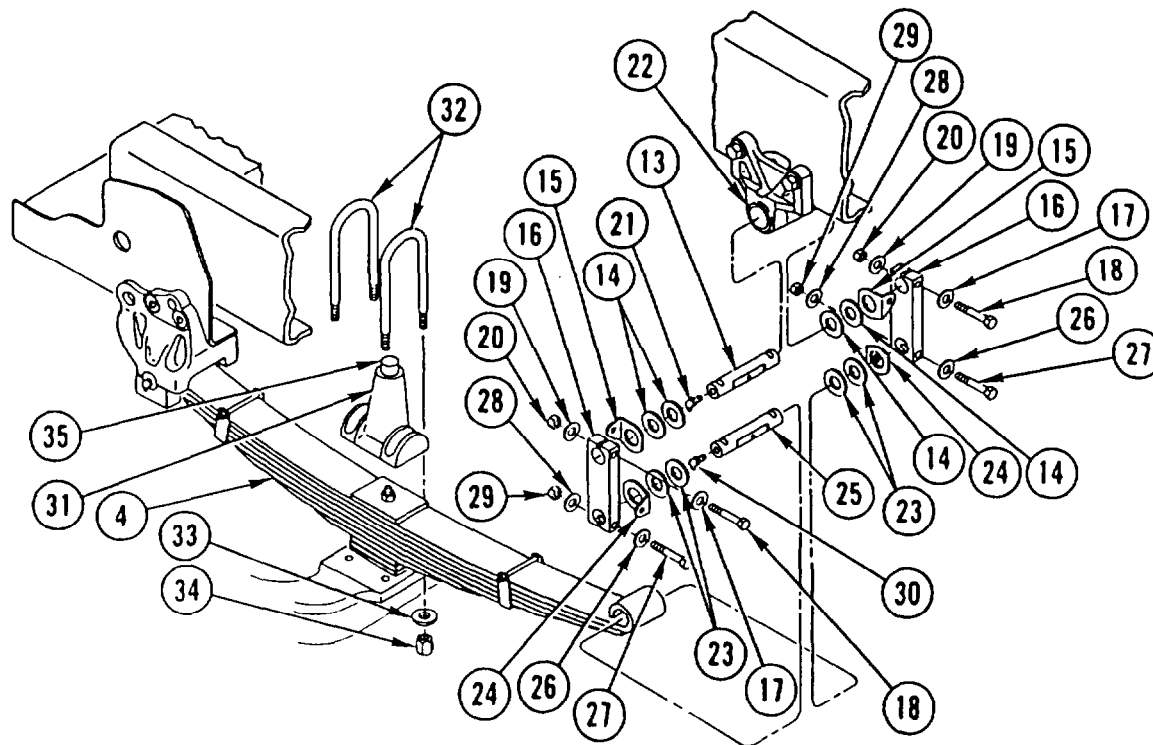

5. INSTALL PIN (13), FOUR SHIMS (14), TWO WEAR PLATES (15), TWO SHACKLES (16), TWO WASHERS (17), TWO SCREWS (18), TWO WASHERS (19), TWO NUTS (20), AND GREASE FITTING (21) IN REAR SPRING HANGER (22).
6. POSITION SPRING (4) IN TWO SHACKLES (16) AND INSTALL FOUR SHIMS (23), TWO WEAR PLATES (24), AND PIN (25).
7. ALINE GROOVES IN PIN (25) WITH HOLES IN TWO SHACKLES (16) AND CHECK END PLAY. END PLAY SHOULD BE NO MORE THAN 1/32 IN. (0.8 mm). ADD SHIMS TO CORRECT END PLAY. IF POSSIBLE, ADD SAME NUMBER OF SHIMS ON EACH SIDE OF PIN (25).
8. INSTALL TWO WASHERS (26), TWO SCREWS (27), TWO WASHERS (28), TWO NUTS (29), AND GREASE FITTING (30).

CAUTION

Incorrect installation of axle stop will cause damage to axle and frame during use.

9. INSTALL AXLE STOP (31) IN POSITION NOTED DURING REMOVAL. INSTALL TWO U-BOLTS (32), FOUR WASHERS (33), AND FOUR NUTS (34). TIGHTEN NUTS TO 380-460 LB-FT (515-624 N.m).
10. INSTALL STOP CUSHION (35) IN AXLE STOP (31).

NOTE

Follow-on Maintenance:
Install front wheel (TM 9-2320-363-10).

FRONT SPRING HANGERS REPLACEMENT

This task covers: a. Removal b. Cleaning c. Inspection d. Installation

INITIAL SETUP

Tools and Special Equipment:

Shop Equipment, SC 4910-95-CL-A31
Tool Kit, SC 5180-90-CL-N05

Equipment Condition:

Reference	Condition Description
Page 9-1	Front Spring Removed
Page 7-4	Steering Gear Removed (Left Spring Only)

REMOVAL

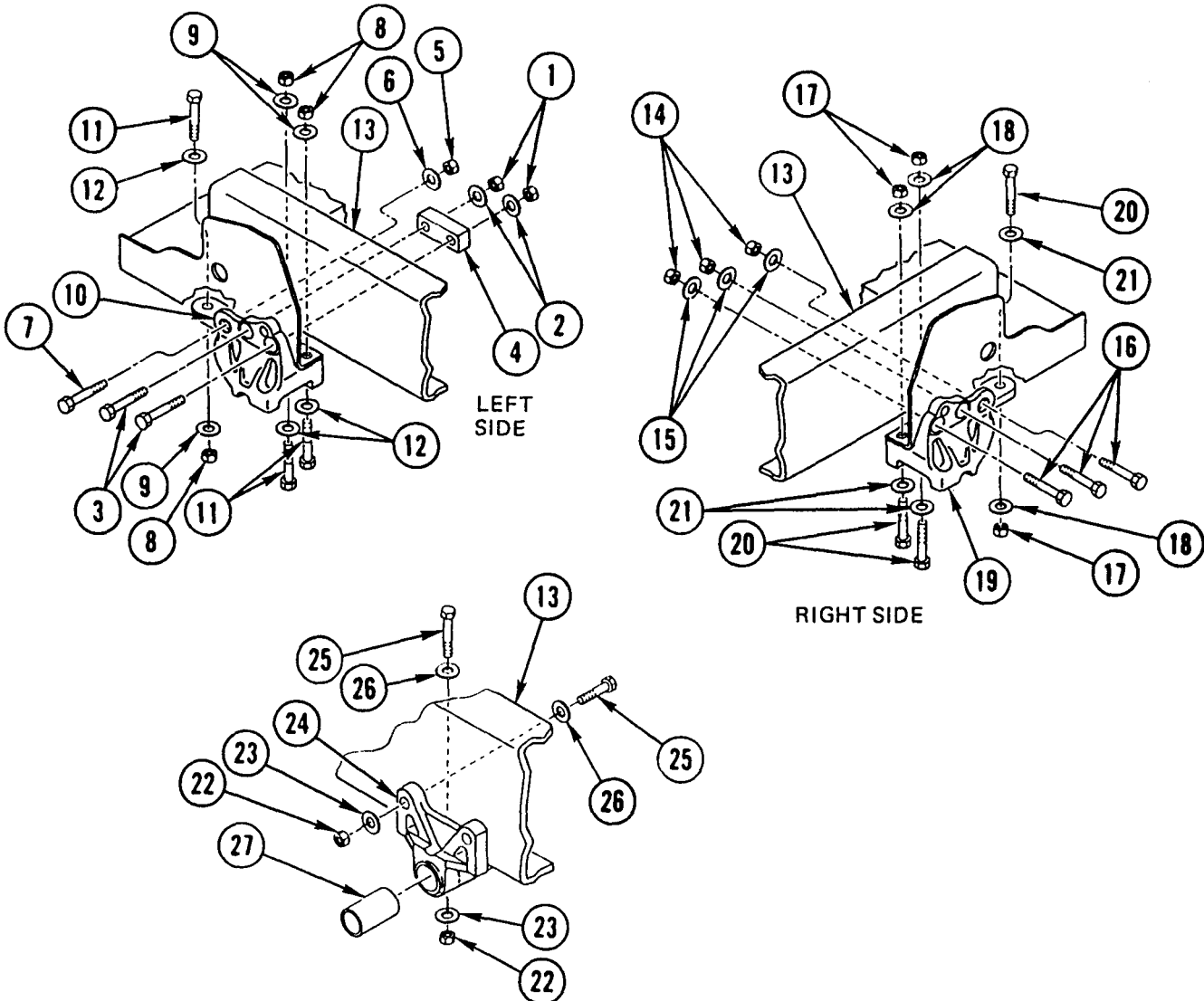

NOTE

Perform steps 1 thru 3 on left side only.

1. REMOVE TWO NUTS (1), TWO WASHERS (2), TWO SCREWS (3), AND THREADED BLOCK (4).
2. REMOVE NUT (5), WASHER (6), AND SCREW (7).
3. REMOVE THREE NUTS (8), THREE WASHERS (9), SPRING HANGER (10), THREE SCREWS (11), AND THREE WASHERS (12) FROM FRAME (13).

NOTE

Perform steps 4 and 5 on right side only.

4. REMOVE THREE NUTS (14), THREE WASHERS (15), AND THREE SCREWS (16),
5. REMOVE THREE NUTS (17), THREE WASHERS (18), SPRING HANGER (19), THREE SCREWS (20), AND THREE WASHERS (21) FROM FRAME (13).

NOTE

Perform steps 6 and 7 on rear spring hangers.

6. REMOVE FOUR NUTS (22), FOUR WASHERS (23), SPRING HANGER (24), FOUR SCREWS (25), AND FOUR WASHERS (26) FROM FRAME (13).
7. IF DAMAGED, REMOVE BUSHING (27) FROM SPRING HANGER (24).

CLEANING

Use general cleaning methods to clean all parts (page 2-30).

INSPECTION

Inspect all parts for wear or damage.

FRONT SPRING HANGERS REPLACEMENT (CONT)

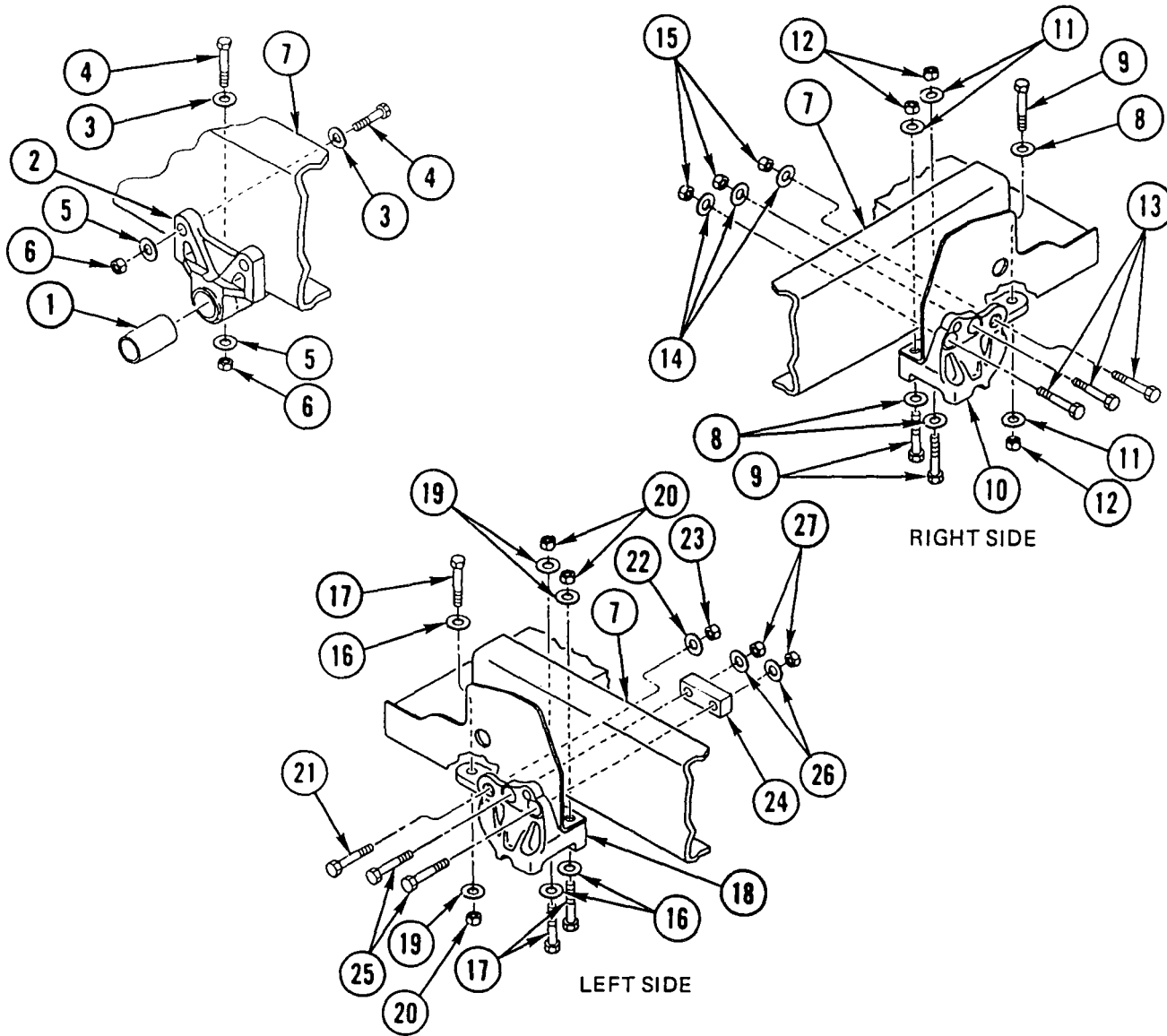

NOTE

Perform steps 1 and 2 on rear spring hangers.

1. IF REMOVED, INSTALL NEW BUSHING (1) IN SPRING HANGER (2).
2. INSTALL FOUR WASHERS (3), FOUR SCREWS (4), SPRING HANGER (2), FOUR WASHERS (5), AND FOUR NUTS (6) ON FRAME (7).

NOTE

Perform steps 3 and 4 on right side only.

3. INSTALL THREE WASHERS (8), THREE SCREWS (9), SPRING HANGER (10), THREE WASHERS (11), AND THREE NUTS (12) ON FRAME (7).
4. INSTALL THREE SCREWS (13), THREE WASHERS (14), AND THREE NUTS (15).

NOTE

Perform steps 5 thru 7 on left side only.

5. INSTALL THREE WASHERS (16), THREE SCREWS (17), SPRING HANGER (18), THREE WASHERS (19), AND THREE NUTS (20).
6. INSTALL SCREW (21), WASHER (22), AND NUT (23).
7. INSTALL THREADED BLOCK (24), TWO SCREWS (25), TWO WASHERS (26), AND TWO NUTS (27).

NOTE

Follow-on Maintenance:

Install front spring (page 9-1).

Install steering gear (left spring only) (page 7-4).

REAR SPRING AND SADDLE ASSEMBLY REPLACEMENT

This task covers: a. Removal b. Cleaning c. Inspection d. Installation

INITIAL SETUP

Tools and Special Equipment:

Shop Equipment, SC 4910-95-CL-A31
Tool Kit, SC 5180-90-CL-N05

General Safety Instructions:

WARNING

Spring and saddle assembly weighs 420 lb (190 kg). Use floor jack to lift and support spring and saddle assembly. Failure to do so could result in injury to personnel.

Equipment Condition:

Reference	Condition Description
Page 9-22 or 9-28	Equalizing Beam Removed

REMOVAL

WARNING

Spring and saddle assembly weighs 420 lb (190 kg). Use floor jack to lift and support spring and saddle assembly. Failure to do so could result in injury to personnel.

1. USING FLOOR JACK, SUPPORT SPRING AND SADDLE ASSEMBLY (1).
2. REMOVE TWO NUTS (2), TWO WASHERS (3), TWO SCREWS (4), TWO WASHERS (5), AND PIN (6) FROM FORWARD MOUNTING BRACKET (7).
3. REMOVE FITTING (8) FROM PIN (6),
4. REMOVE NUT (9), WASHER (10), SCREW (11), WASHER (12), AND SPACER (13) FROM REAR MOUNTING BRACKET (14).
5. LOWER SPRING AND SADDLE ASSEMBLY (1) AND REMOVE SPACER (15).

CLEANING

Use general cleaning methods to clean all park (page 2-30).

INSPECTION

Inspect all parts for wear or damage.

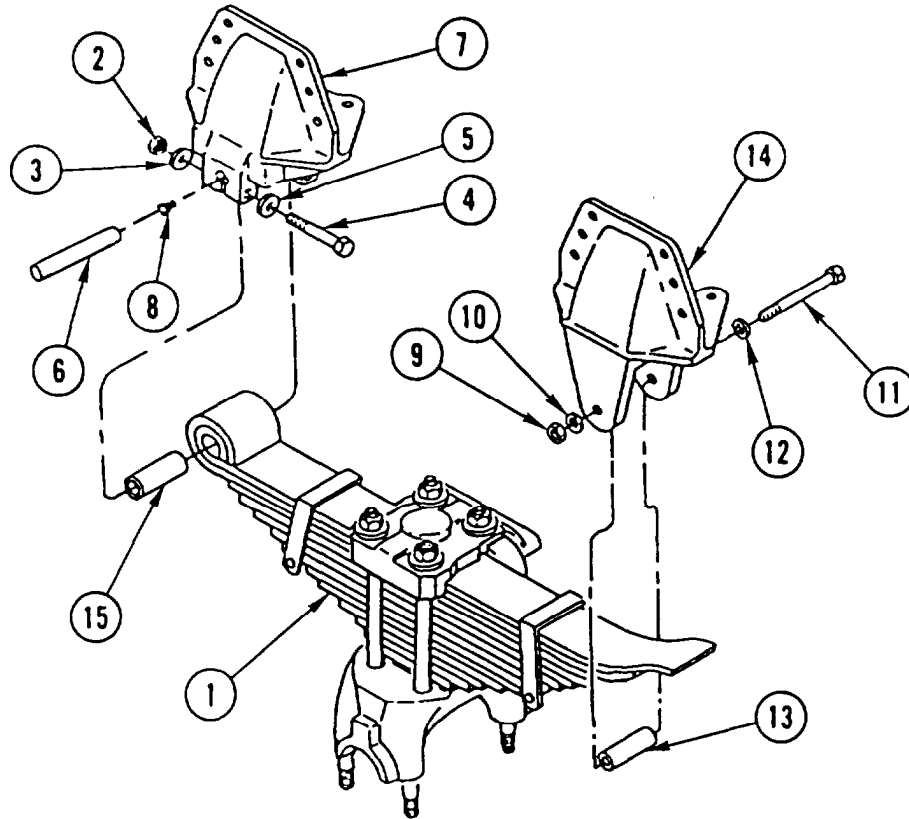

INSTALLATION

1. INSTALL SPACER (15).

WARNING

Spring and saddle assembly weighs 420 lb (190 kg). Use floor jack to lift and support spring and saddle assembly. Failure to do so could result in injury to personnel.

2. USING FLOOR JACK, RAISE SPRING AND SADDLE ASSEMBLY (1) INTO POSITION.
3. INSTALL SPACER (13), WASHER (12), SCREW (11), WASHER (10), AND NUT (9) IN REAR MOUNTING BRACKET (14).
4. INSTALL FITTING (8) IN PIN (6).
5. INSTALL PIN (6), TWO WASHERS (5), TWO SCREWS (4), TWO WASHERS (3), AND TWO NUTS (2) IN FORWARD MOUNTING BRACKET (7).

NOTE

Follow-on Maintenance:
Install equalizing beam (page 9-22 or 9-28).

TORQUE ROD REPLACEMENT

This task covers: a. Removal b. Cleaning c. Inspection d. Installation

INITIAL SETUP

Tools and Special Equipment:

Shop Equipment, SC 4910-95-CL-A31
Tool Kit, SC 5180-90-CL-N05

References:

TM 9-2320-363-20

Equipment Condition:

Reference

TM 9-2320-363-20

Condition Description

Vehicle Blocked

REMOVAL

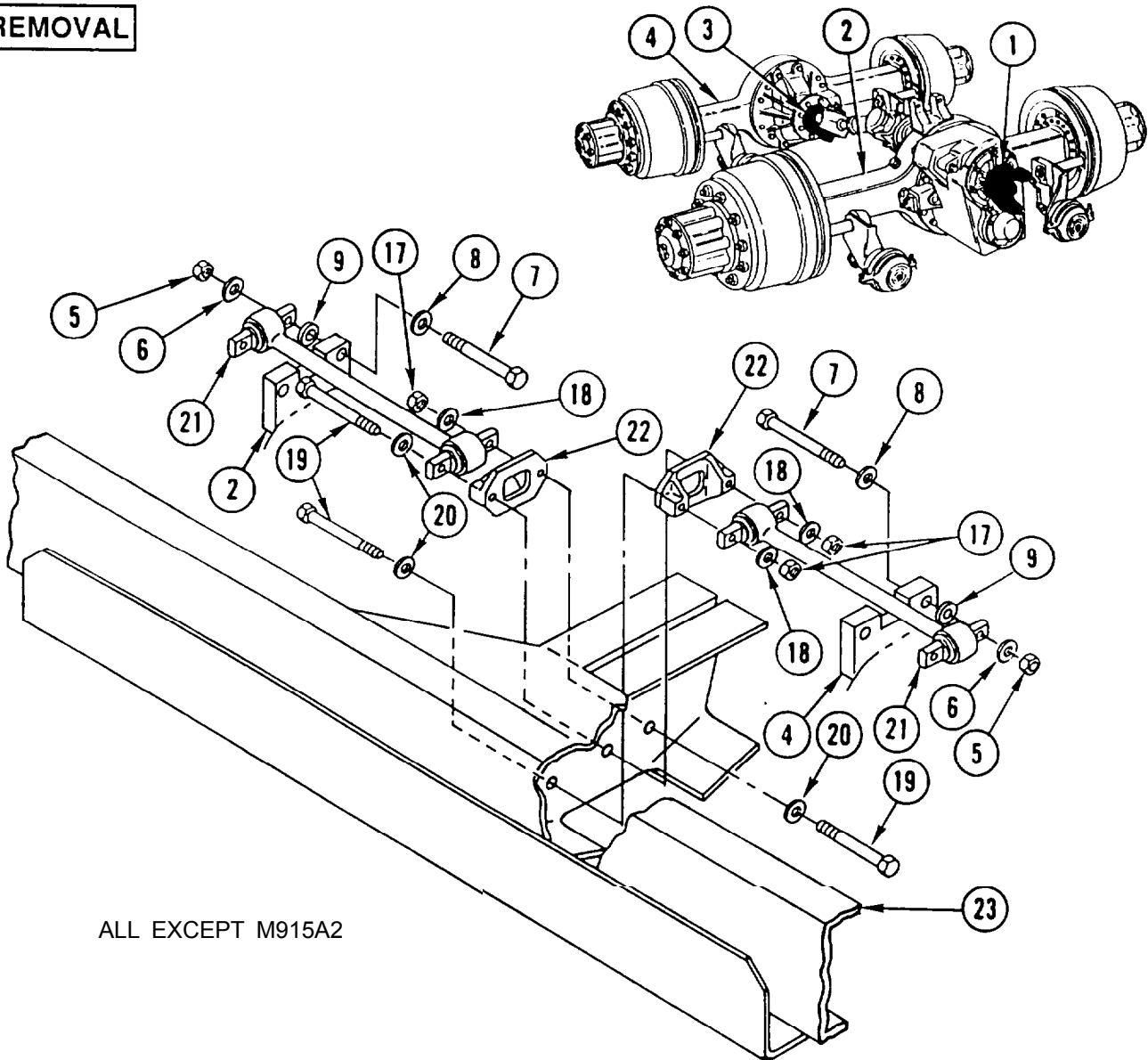

ALL EXCEPT M915A2

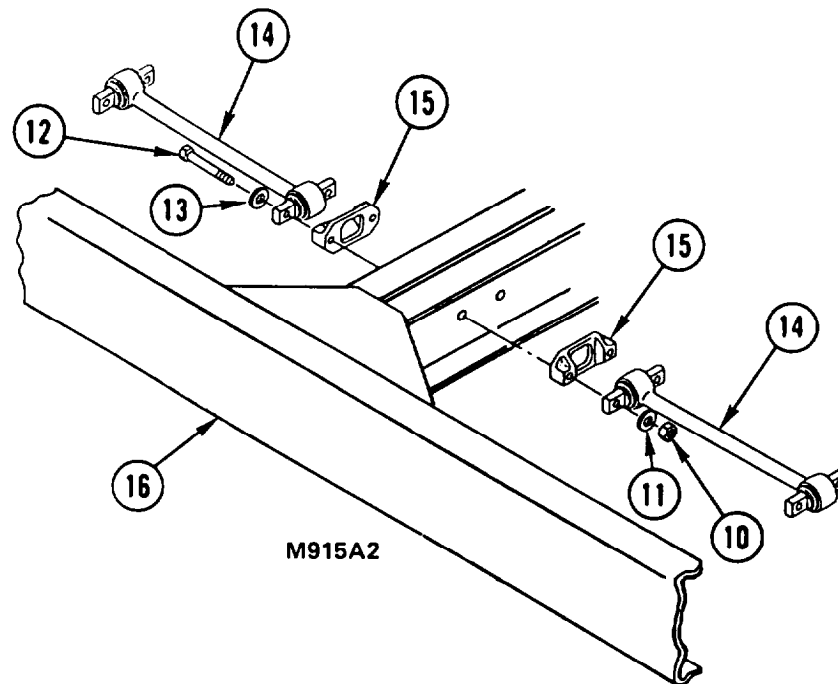

NOTE

Steps 1 thru 3 are the same for all vehicles.

1. USING SUITABLE JACK STANDS, SUPPORT INPUT YOKE (1) OF FORWARD-REAR AXLE (2) AND INPUT YOKE (3) OF REAR AXLE (4).

NOTE

Tag spacer washers prior to removal to aid in installation.

2. REMOVE TWO NUTS (5), TWO WASHERS (6), TWO SCREWS (7), TWO WASHERS (8), AND TWO SPACER WASHERS (9) FROM FORWARD-REAR AXLE (2).
3. REPEAT STEP 2 TO DISCONNECT TORQUE ROD FROM REAR AXLE (4).

NOTE

Perform step 4 for M915A2. Perform step 5 for all except M915A2.

4. REMOVE TWO NUTS (10), TWO WASHERS (11), TWO SCREWS (12), TWO WASHERS (13), TWO TORQUE RODS (14), AND TWO MOUNTING BRACKETS (15) FROM FRAME (16).
5. REMOVE THREE NUTS (17), THREE WASHERS (18), THREE SCREWS (19), THREE WASHERS (20), TWO TORQUE RODS (21), AND TWO MOUNTING BRACKETS (22) FROM FRAME (23).

CLEANING

Use general cleaning methods to clean all parts (page 2-30).

INSPECTION

Inspect all pans for wear or damage.

TORQUE ROD REPLACEMENT (CONT)

INSTALLATION

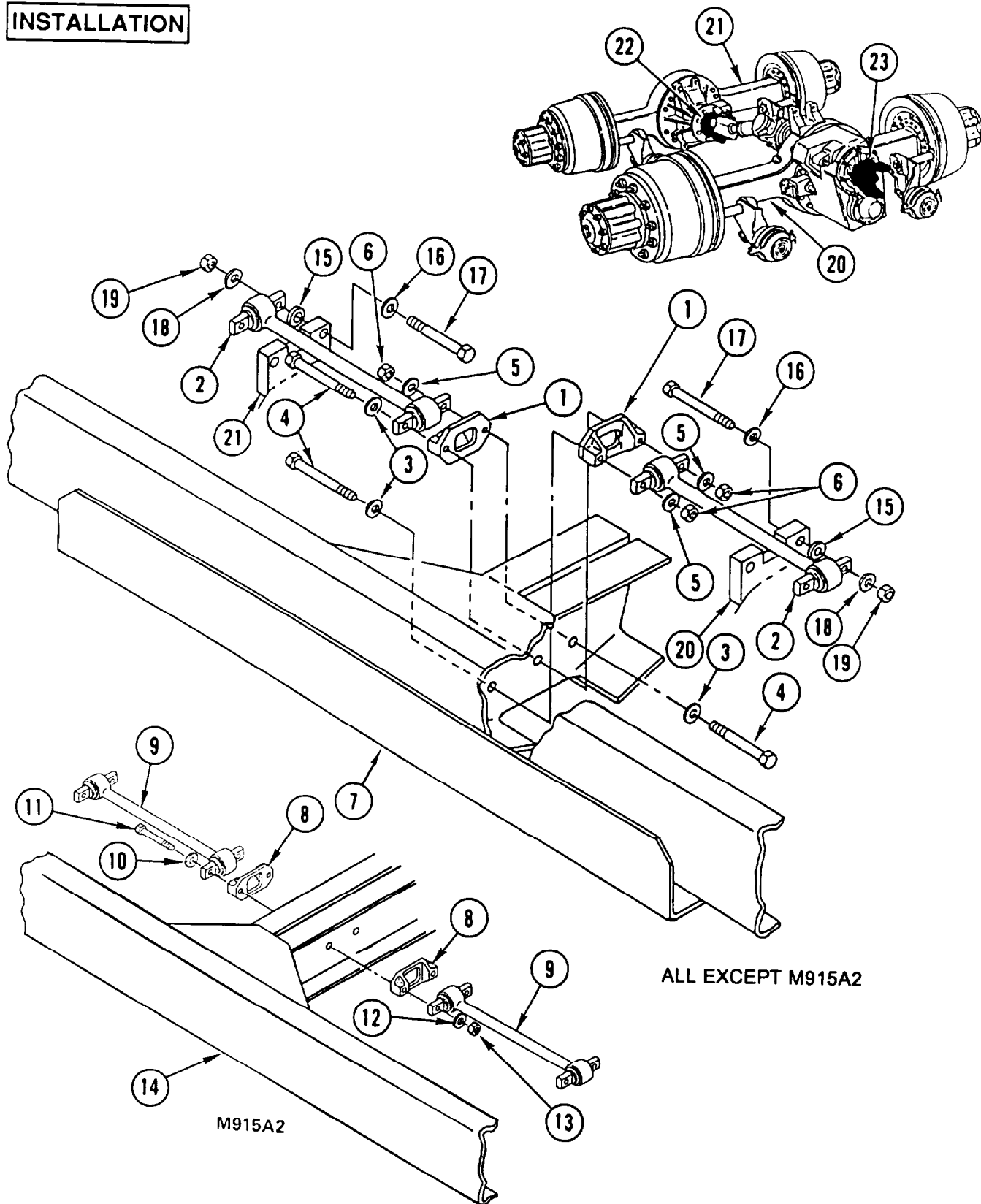

NOTE

Perform step 1 for all except M915A2. Perform step 2 for M915A2.

1. INSTALL TWO MOUNTING BRACKETS (1), TWO TORQUE RODS (2), THREE WASHERS (3), THREE SCREWS (4), THREE WASHERS (5), AND THREE NUTS (6) ON FRAME (7).
2. INSTALL TWO MOUNTING BRACKETS (8), TWO TORQUE RODS (9), TWO WASHERS (10), TWO SCREWS (11), TWO WASHERS (12), AND TWO NUTS (13) ON FRAME (14).

NOTE

Steps 3 thru 5 are the same for all vehicles.

3. INSTALL TWO SPACER WASHERS (15), TWO WASHERS (16), TWO SCREWS (17), TWO WASHERS (18), AND TWO NUTS (19) IN FORWARD-REAR AXLE (20).
4. REPEAT STEP 3 TO CONNECT TORQUE ROD TO REAR AXLE (21)
5. REMOVE JACKSTANDS FROM UNDER INPUT YOKE (22) OF REAR AXLE (21) AND FROM UNDER INPUT YOKE (23) OF FORWARD-REAR AXLE (20).

REAR SPRING HANGER REPLACEMENT

This task covers: a. Removal b. Cleaning c. Inspection d. Installation

INITIAL SETUP

Tools and Special Equipment:

Shop Equipment, SC 4910-95-CL-A31
Tool Kit, SC 5180-90-CL-N05

Equipment Condition:

Reference
Page 9-12

Condition Description
Rear Spring and Saddle
Assembly Removed

REMOVAL

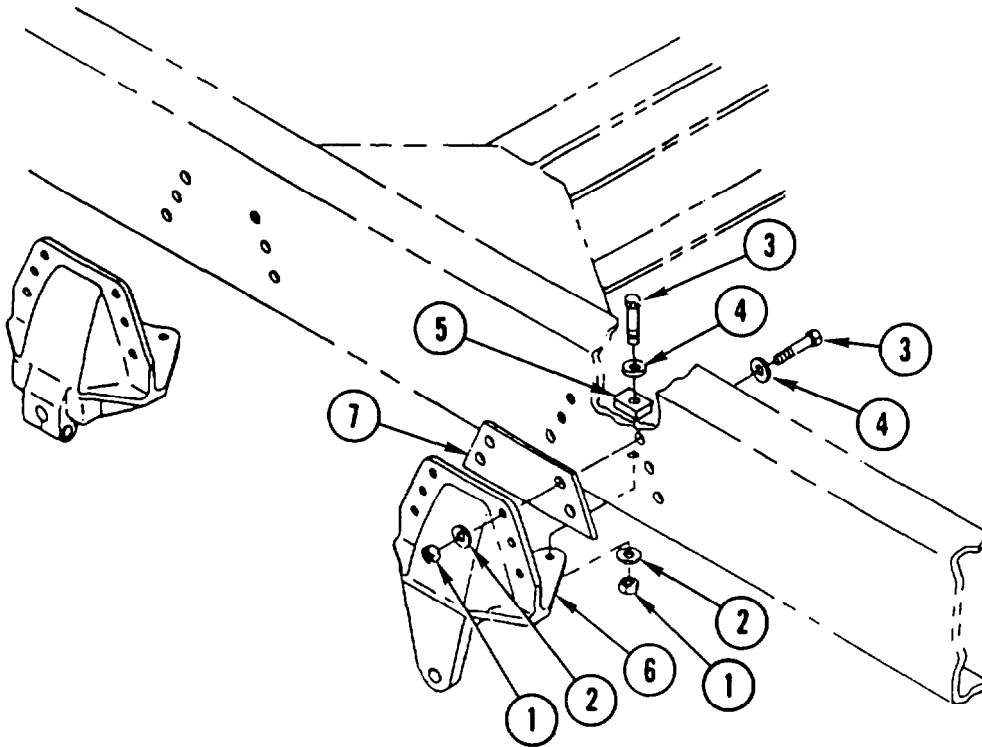

NOTE

- Procedure is the same for both front and rear spring hangers.
- Step 1 is for M915A2 only.

1. REMOVE EIGHT NUTS (1), EIGHT WASHERS (2), EIGHT SCREWS (3), EIGHT WASHERS (4), TWO SPACERS (5), SPRING HANGER (6), AND SPACER (7).

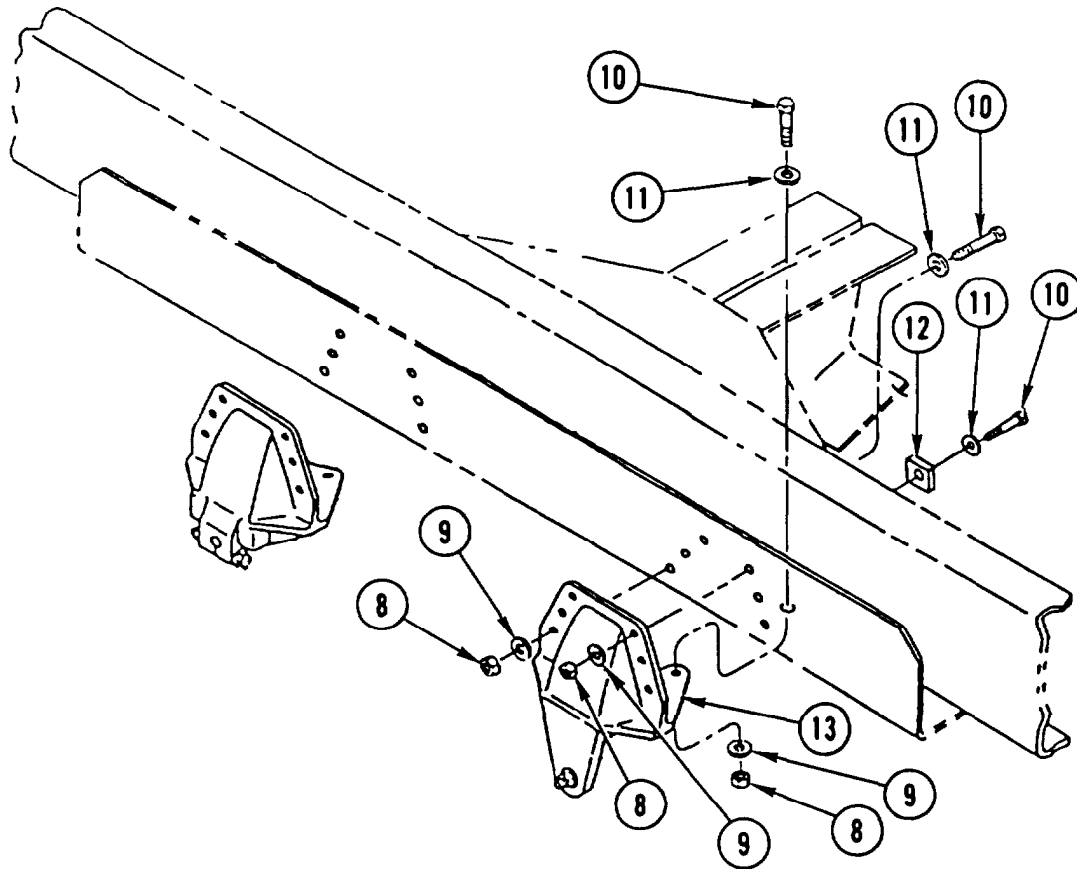

NOTE

Step 2 is for all except M915A2.

2. REMOVE EIGHT NUTS (8), EIGHT WASHERS (9), EIGHT SCREWS (10), EIGHT WASHERS (11), TWO SPACERS (12), AND SPRING HANGER (13).

CLEANING

Use general cleaning methods to clean all parts (page 2-30).

INSPECTION

Inspect all parts for wear or damage.

REAR SPRING HANGER REPLACEMENT (CONT)

INSTALLATION

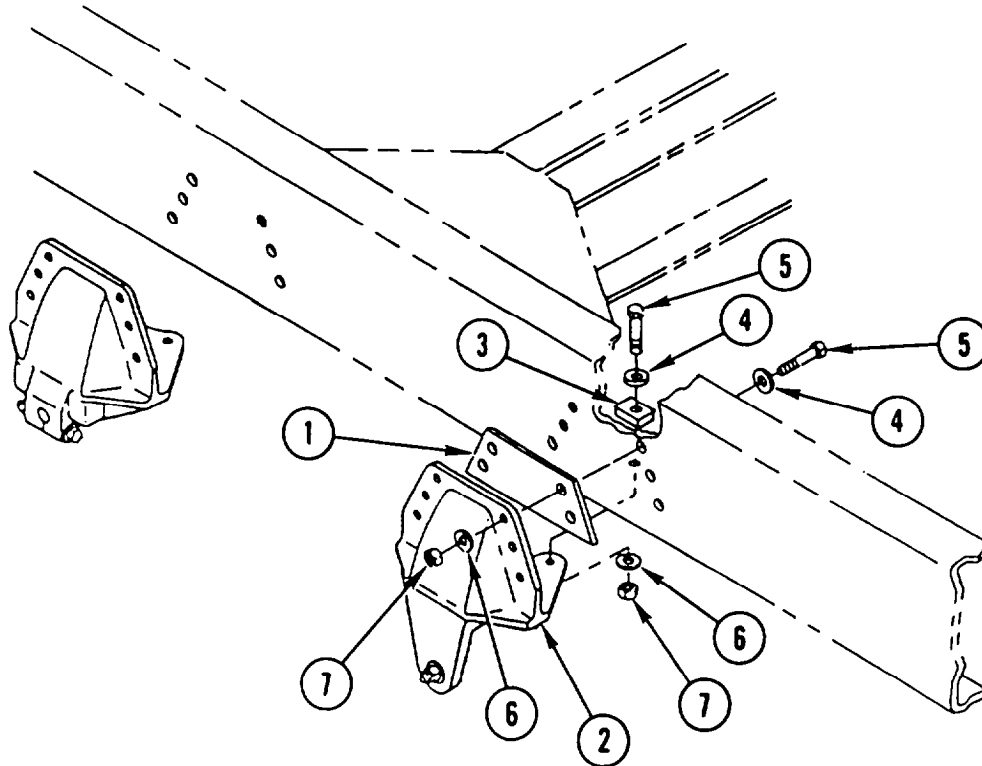

NOTE

- Procedure is the same for both front and rear spring hangers.
- Step 1 is for M915A2 only.

1. INSTALL SPACER (1), SPRING HANGER (2), TWO SPACERS (3), EIGHT WASHERS (4), EIGHT SCREWS (5), EIGHT WASHERS (6), AND EIGHT NUTS (7). TIGHTEN NUTS TO 62-84 LB-FT (84-114 N.m).

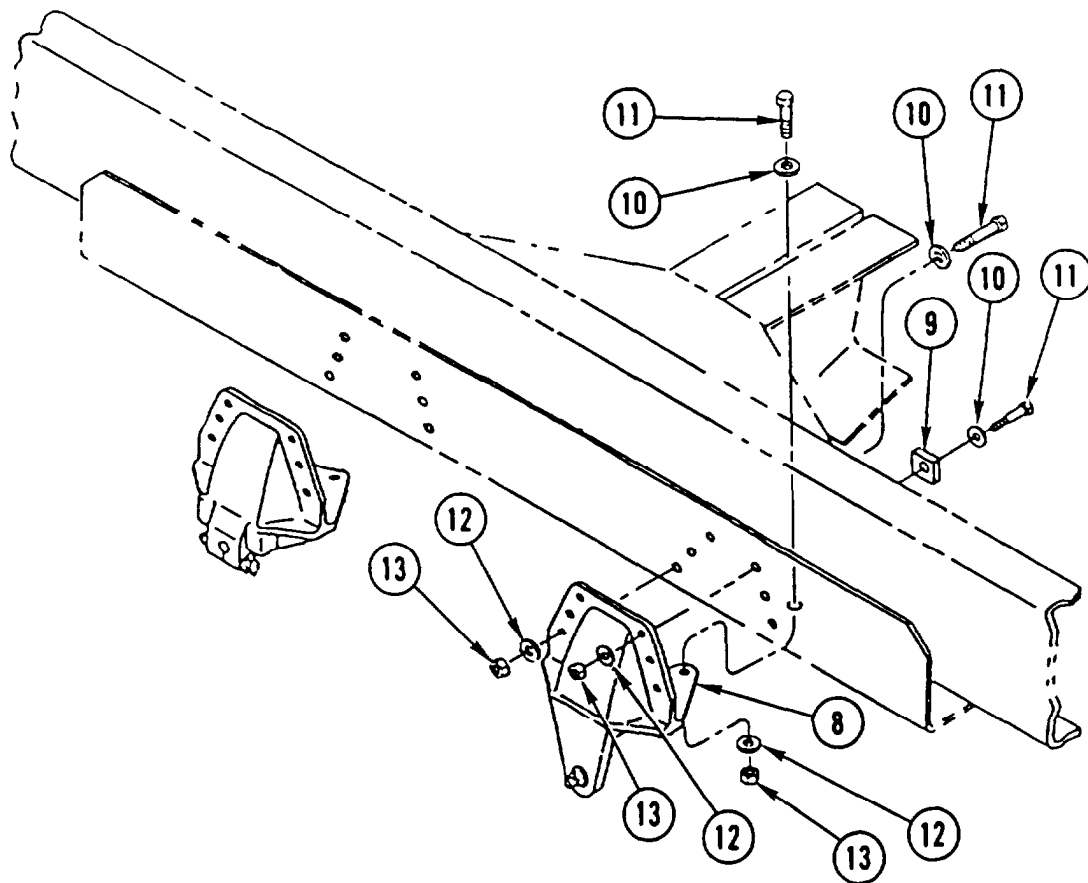

NOTE

Step 2 is for all except M915A2.

2. INSTALL SPRING HANGER (8), TWO SPACERS (9), EIGHT WASHERS (10), EIGHT SCREWS (11), EIGHT WASHERS (12), AND EIGHT NUTS (13).

NOTE

Follow-on Maintenance:
Install rear spring and saddle assembly (page 9-12).

EQUALIZING BEAM REPLACEMENT

This task covers: a. Removal b. Cleaning c. Inspection d. Installation

INITIAL SETUP

Applicable Configuration:

M915A2

Tools and Special Equipment:

Shop Equipment, SC 4910-95-CL-A31
Tool Kit, SC 5180-90-CL-N05

Materials/Parts:

Adapter (8) P/N 45163

References:

TM 9-2320-363-20

Equipment Condition:

Reference	Condition Description
TM 9-2320-363-20	Air System Drained
TM 9-2320-363-20	Rear Brakeshoe and Linings Removed

General Safety Instructions:

<p style="text-align: center;">WARNING</p> <p>Make sure all air lines and fittings are clear of debris. Failure to do so could result in equipment failure and/or injury to personnel.</p>

REMOVAL

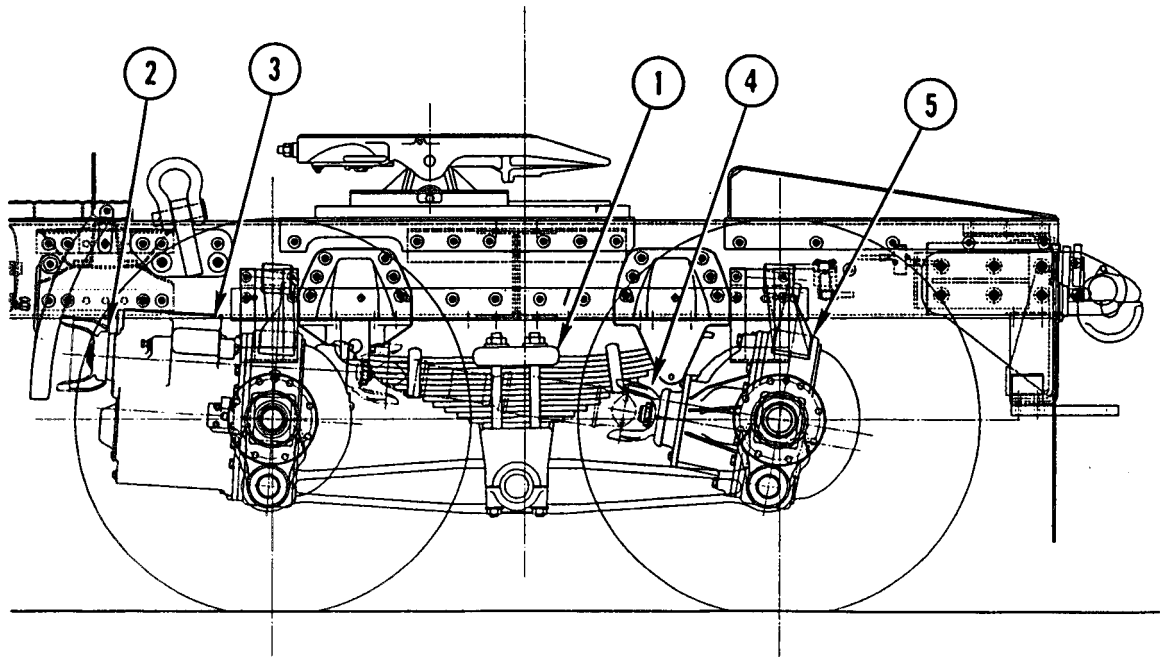

1. USING SUITABLE LIFTING DEVICE AND JACK STANDS, LIFT AND SUPPORT REAR OF VEHICLE SO THAT WEIGHT IS RELIEVED FROM BOTH REAR SPRINGS (1).
2. POSITION JACK STAND TO SUPPORT INPUT YOKE (2) OF FORWARD-REAR AXLE (3). POSITION JACK STAND TO SUPPORT INPUT YOKE (4) OF REAR AXLE (5).

EQUALIZING BEAM REPLACEMENT (CONT)

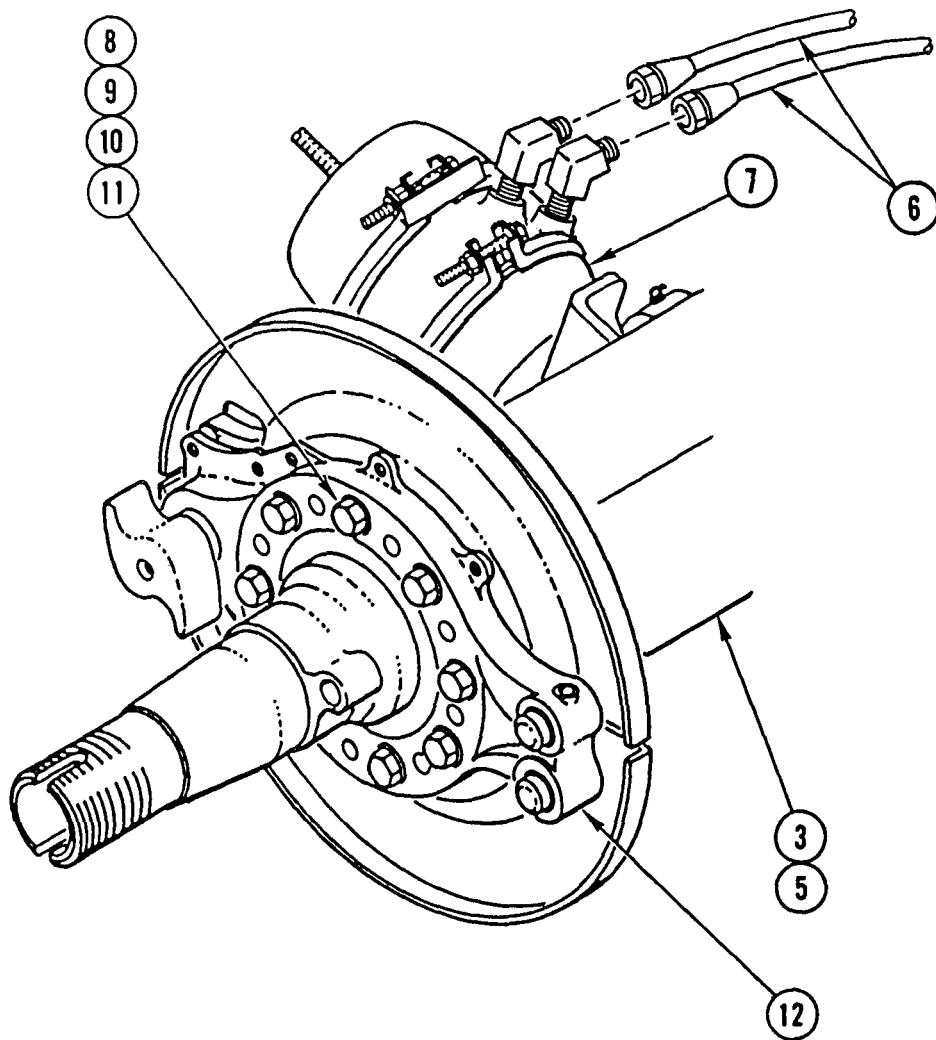

NOTE

Steps 3 thru 5 are for rear axle.

3. REMOVE FOUR AIR HOSES (6) FROM REAR BRAKE CHAMBERS (7).

NOTE

Spider assembly consists of air brake chamber, S-cam, and slack adjuster.

4. REMOVE 16 NUTS (8), 16 WASHERS (9), 16 SCREWS (10), 16 WASHERS (11), AND 2 SPIDER ASSEMBLIES (12) FROM BOTH SIDES OF REAR AXLE (5).
5. USING SUITABLE FLOOR JACK, SUPPORT REAR AXLE (5).
6. REPEAT STEPS 3 THRU 5 FOR FORWARD-REAR AXLE (3).

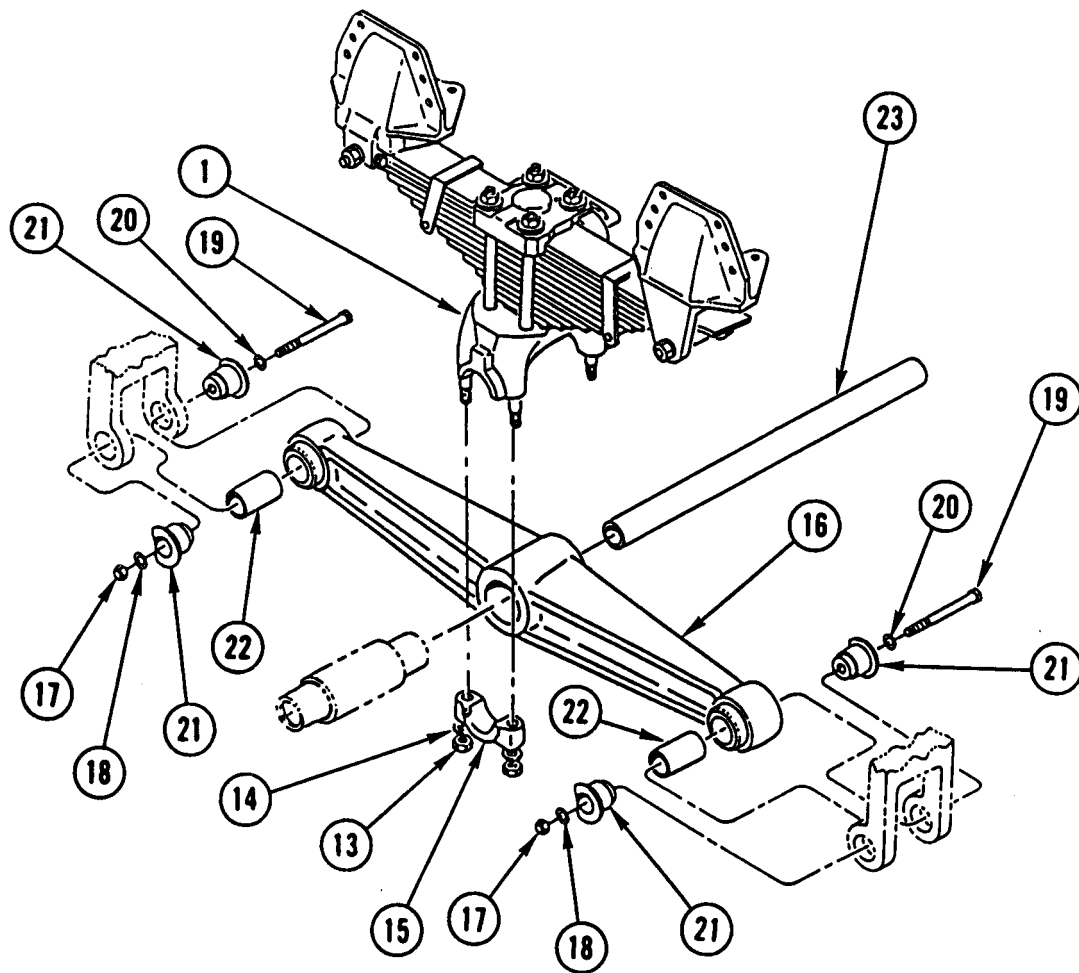

7. REMOVE EIGHT NUTS (13), EIGHT WASHERS (14), AND FOUR SADDLE CAPS (15) FROM TWO SPRING ASSEMBLIES (1).
8. USING BLOCK OF WOOD AND JACK STAND, SUPPORT REAR ENDS OF TWO EQUALIZING BEAMS (16). REMOVE TWO NUTS (17), TWO WASHERS (18), TWO SCREWS (19), TWO WASHERS (20), AND FOUR ADAPTERS (21) FROM REAR END OF TWO EQUALIZING BEAMS (16). DISCARD ADAPTERS.
9. LOWER REAR ENDS OF TWO EQUALIZING BEAMS (16) ONTO BLOCKS.
10. REPEAT STEPS 8 AND 9 FOR FRONT END OF TWO EQUALIZING BEAMS (16).
11. REMOVE FOUR INTERMEDIATE TUBES (22) FROM TWO EQUALIZING BEAMS (16).
12. REMOVE ONE EQUALIZING BEAM (16) FROM BLOCKS AND REMOVE CROSSTUBE (23) FROM OTHER EQUALIZING BEAM (16).

CLEANING

Use general cleaning methods to clean all parts (page 2-30).

EQUALIZING BEAM REPLACEMENT (CONT)

INSPECTION

Inspect all parts for wear or damage.

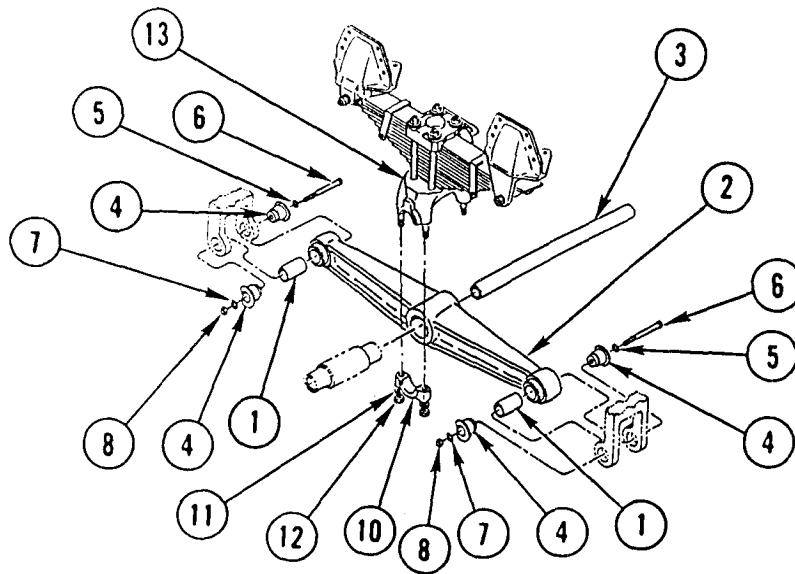

WARNING

Make sure all air lines and fittings are clear of debris. Failure to do so could result in equipment failure and/or injury to personnel.

1. INSTALL FOUR INTERMEDIATE TUBES (1) IN TWO EQUALIZING BEAMS (2).
2. POSITION ONE EQUALIZING BEAM (2) ON BLOCKS UNDER VEHICLE AND INSTALL CROSSTUBE (3).
3. INSTALL SECOND EQUALIZING BEAM (2) ON CROSSTUBE (3) AND BLOCKS UNDER VEHICLE.

NOTE

Rotate adapters so flat side is vertical. Do not tighten adapters until both ends are installed.

4. USING BLOCK OF WOOD AND JACK STAND, RAISE REAR ENDS OF TWO EQUALIZING BEAMS (2). INSTALL FOUR NEW ADAPTERS (4), TWO WASHERS (5), TWO SCREWS (6), TWO WASHERS (7), AND TWO NUTS (8) HAND-TIGHT.

5. REPEAT STEP 4 FOR FRONT END OF TWO EQUALIZING BEAMS (2) IN FORWARD-REAR AXLE (9).
6. TIGHTEN FOUR NUTS (8) TO 210-240 LB-FT (285-325 N.m).
7. INSTALL FOUR SADDLE CAPS (10), EIGHT WASHERS (11), AND EIGHT NUTS (12) ON TWO SPRING ASSEMBLIES (13). TIGHTEN NUTS TO 225-275 LB-FT (305-373 N.m).

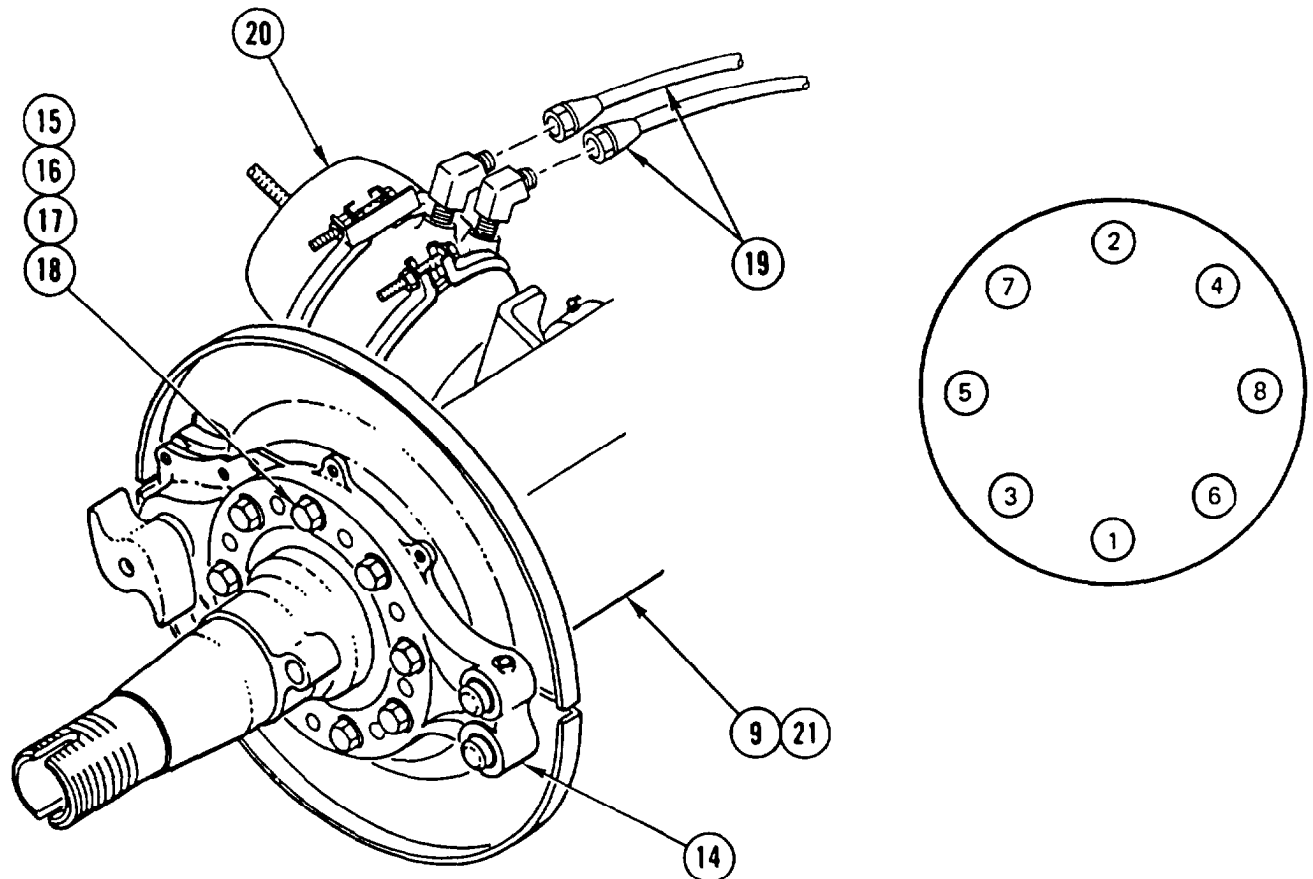

NOTE

Steps 8 and 9 are for forward-rear axle.

8. REPOSITION FLOOR JACK FROM STEP 5 OF REMOVAL AND INSTALL 2 SPIDER ASSEMBLIES (14), 16 WASHERS (15), 16 SCREWS (16), 16 WASHERS (17), AND 16 NUTS (18) ON BOTH SIDES OF FORWARD-REAR AXLE (9). TIGHTEN NUTS TO 150-175 LB-FT (203.4-237.3 N.m) IN SEQUENCE SHOWN.
9. INSTALL FOUR AIR HOSES (19) IN BRAKE CHAMBERS (20).
10. REPEAT STEPS 8 AND 9 FOR REAR AXLE (21).

NOTE

Follow-on Maintenance:
Install rear brakeshoe and linings (TM 9-2320-363-20).

EQUALIZING BEAM REPLACEMENT

This task covers: a. Removal b. Cleaning c. Inspection d. Installation

INITIAL SETUP

Applicable Configuration:

■ All except M915A2

Tools and Special Equipment:

Shop Equipment, SC 4910-95-CL-A31

Tool Kit, SC 5180-90-CL-N05

Materials/Parts:

Adapter (4) P/N 45871

■ Mounting Hardware PIN 56659-001
Set

References:

TM 9-2320-363-20

Equipment Condition:

Reference	Condition	Description
TM 9-2320-363-20	Air System	Drained
TM 9-2320-363-20	Rear Brakeshoe and Linings	Removed

General Safety Instructions:

WARNING

Make sure all air lines and fittings are clear of debris. Failure to do so could result in equipment failure and/or injury to personnel.

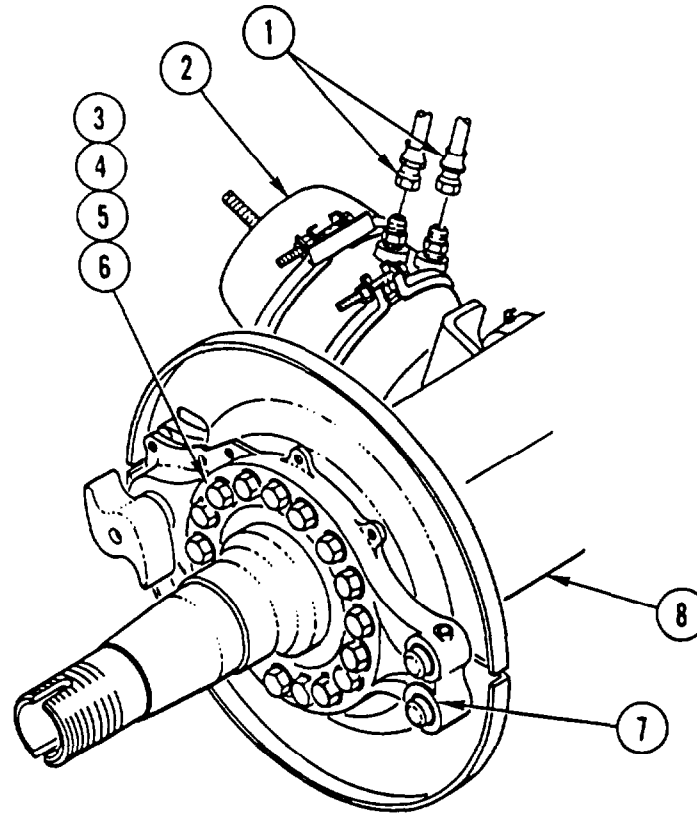
REMOVAL**NOTE**

Procedure is the same for both sides and both ends of equalizing beam

1. USING SUITABLE LIFTING DEVICE AND JACK STANDS, LIFT AND SUPPORT REAR OF VEHICLE SO THAT WEIGHT IS RELIEVED FROM BOTH REAR SPRINGS
2. REMOVE TWO AIR HOSES (1) FROM REAR BRAKE (2).

NOTE

Spider assembly consists of air brake chamber, S-cam, and slack adjuster.

3. REMOVE 16 NUTS (3), 16 WASHERS (4), 16 SCREWS (5), 16 WASHERS (6), AND SPIDER ASSEMBLY (7) FROM REAR AXLE (8).

CAUTION

Place jack stand on nonbearing surface of axle. Failure to do so could result in damage to axle bearing surface.

4. USING SUITABLE JACK STAND, SUPPORT REAR AXLE (8).

EQUALIZING BEAM REPLACEMENT (CONT)

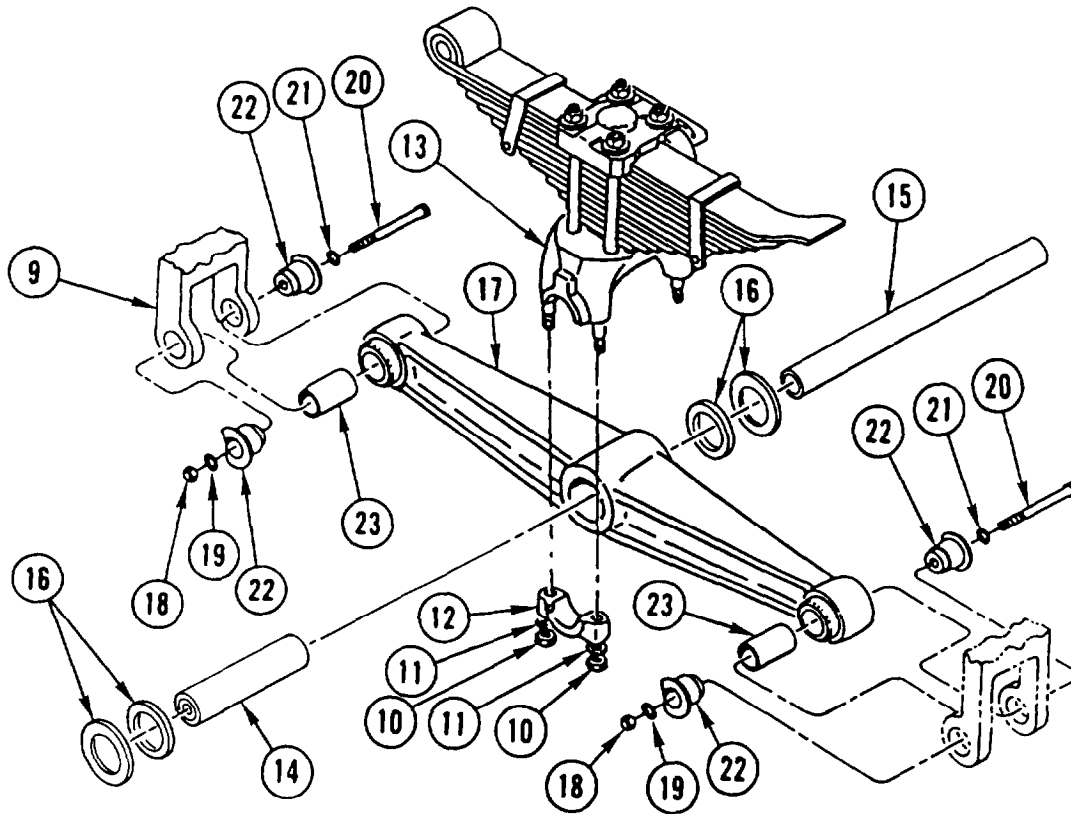

5. REPEAT STEPS 2 THRU 4 FOR FORWARD-REAR AXLE (9).
6. REMOVE FOUR NUTS (10), FOUR WASHERS (11), AND TWO SADDLE CAPS (12) FROM SPRING ASSEMBLY (13).

NOTE

When saddle caps are removed, spring assembly should raise enough to allow removal of sleeve and crosstube. If spring assembly does not raise far enough, lift vehicle enough to remove sleeve and crosstube.

7. REMOVE SLEEVE (14), CROSS TUBE (15), AND FOUR WASHERS (16) FROM EQUALIZING BEAM (17).

NOTE

Perform steps 8 through 10 for M916A1 only.

8. USING FLOOR JACK, SUPPORT REAR END OF EQUALIZING BEAM (17). REMOVE NUT (18), WASHER (19), SCREW (20), WASHER (21), AND TWO ADAPTERS (22). DISCARD ADAPTERS.
9. LOWER END OF EQUALIZING BEAM (17) ONTO BLOCKS AND REMOVE INTERMEDIATE TUBE (23).
10. REPEAT STEPS 8 AND 9 FOR FRONT END OF EQUALIZING BEAM (17).

NOTE

Perform steps 11 through 13 for M916A2, M917A1, and M917A1 w/MCS only.

11. USING FLOOR JACK, SUPPORT REAR END OF EQUALIZING BEAM (17). REMOVE TWO NUTS (24), WASHERS (25), AND BOLTS (26). DISCARD ALL MOUNTING HARDWARE.

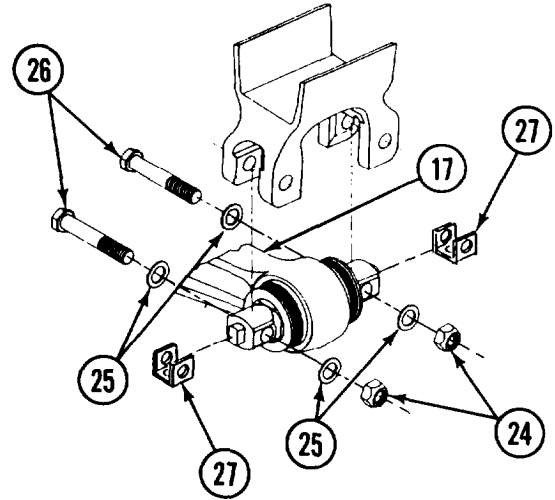
**NOTE**

Note position of shims, while lowering equalizing beam, to aid in installation.

12. LOWER REAR END OF EQUALIZING BEAM (17) AND REMOVE SHIMS (27). TAG SHIMS FOR INSTALLATION.
13. LOWER FRONT END OF EQUALIZING BEAM (17) AND REMOVE SHIMS (27). TAG SHIMS FOR INSTALLATION.

CLEANING

Use general cleaning methods to clean all parts (page 2-30).

INSPECTION

Inspect all parts for wear or damage.

EQUALIZING BEAM REPLACEMENT (CONT)

INSTALLATION

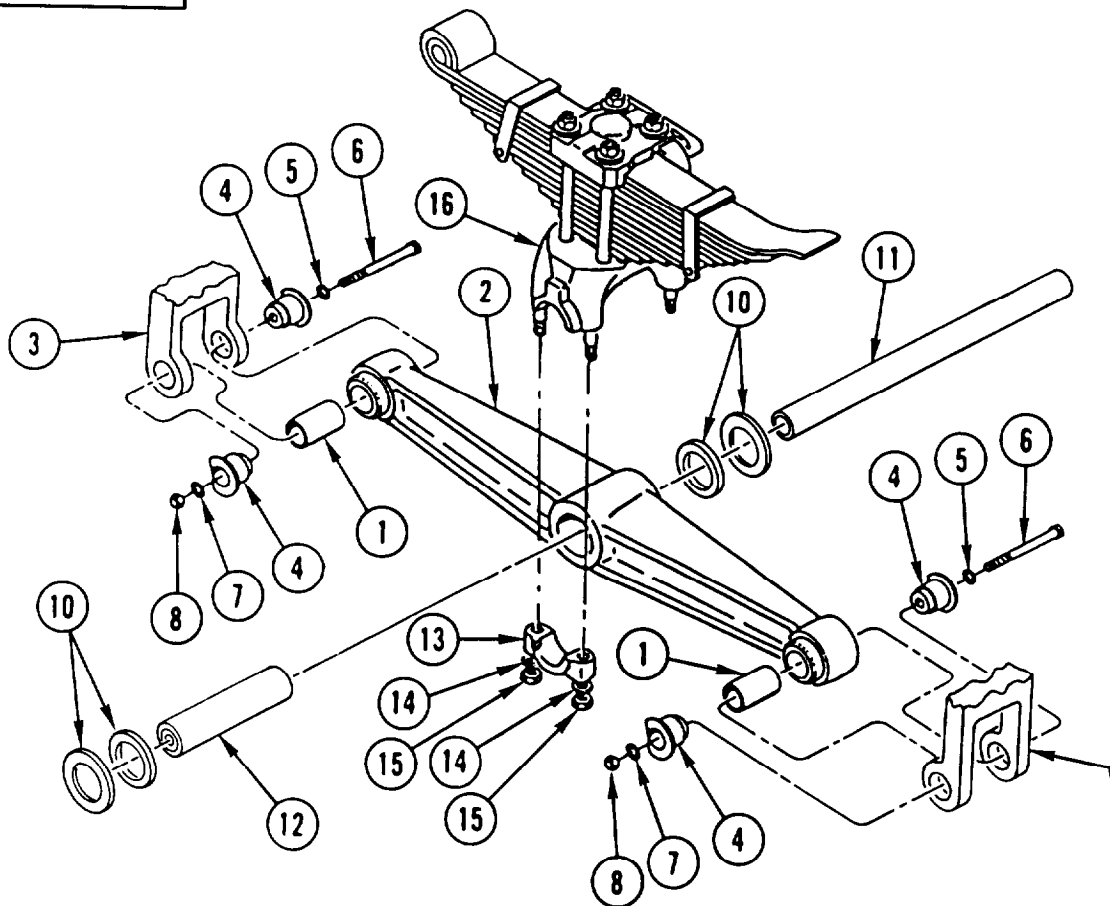

NOTE

Procedure is the same for both sides and both ends of equalizing beam.

1. INSTALL INTERMEDIATE TUBE (1).

NOTE

Perform steps 2 through 5 on M916A1 only.

2. USING SUITABLE LIFTING DEVICE, POSITION FRONT END OF EQUALIZING BEAM (2) IN MOUNTING BRACKET OF FORWARD-REAR AXLE (3).

NOTE

Rotate adapters so flat side is vertical. Do not tighten adapters until both ends are installed.

3. INSTALL TWO NEW ADAPTERS (4), WASHER (5), SCREW (6), WASHER (7), AND NUT (8).
4. REPEAT STEPS 1 THRU 3 FOR REAR END OF EQUALIZING BEAM (2) IN REAR AXLE (9).
5. TIGHTEN TWO NUTS (8) ON BOTH ENDS OF EQUALIZING BEAM (2) TO 210-240 LB-FT (285-325 N.m).

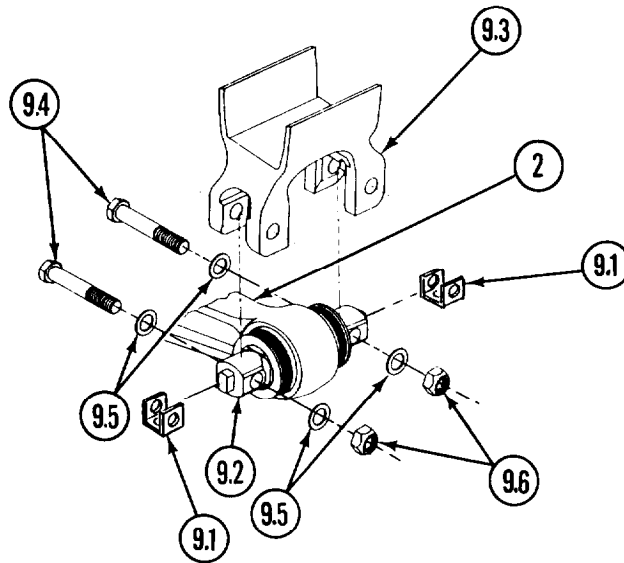

NOTE

- Perform steps 5.1 through 5.6 for M916A2, M917A1, and M917A1 w/MCS only.
- Same number of shims as removed must be installed, in the same location as removed from.

- 5.1. POSITION SHIMS (9.1) ON BAR PINS (9.2).
- 5.2. USING FLOOR JACK, SUPPORT AND RAISE FRONT OF EQUALIZING BEAM (2) INTO AXLE MOUNTING BRACKET (9.3).
- 5.3. INSTALL TWO NEW BOLTS (9.4), WASHERS (9.5), AND NUTS (9.6).
- 5.4. USING FLOOR JACK, SUPPORT AND RAISE REAR OF EQUALIZING BEAM (2) INTO AXLE MOUNTING BRACKET (9.3).
- 5.5. INSTALL TWO NEW BOLTS (9.4), WASHERS (9.5), AND NUTS (9.6).
- 5.6. TIGHTEN TWO FRONT AND TWO REAR NUTS (9.6) TO 450-600 LB-FT (610-814 N.m).
6. INSTALL FOUR WASHERS (10), CROSSTUBE (11), AND SLEEVE (12).
7. INSTALL TWO SADDLE CAPS (13), FOUR WASHERS (14), AND FOUR NUTS (15) ON SPRING ASSEMBLY (16). TIGHTEN NUTS TO 225-275 LB-FT (305-373 N.m).

EQUALIZING BEAM REPLACEMENT (CONT)

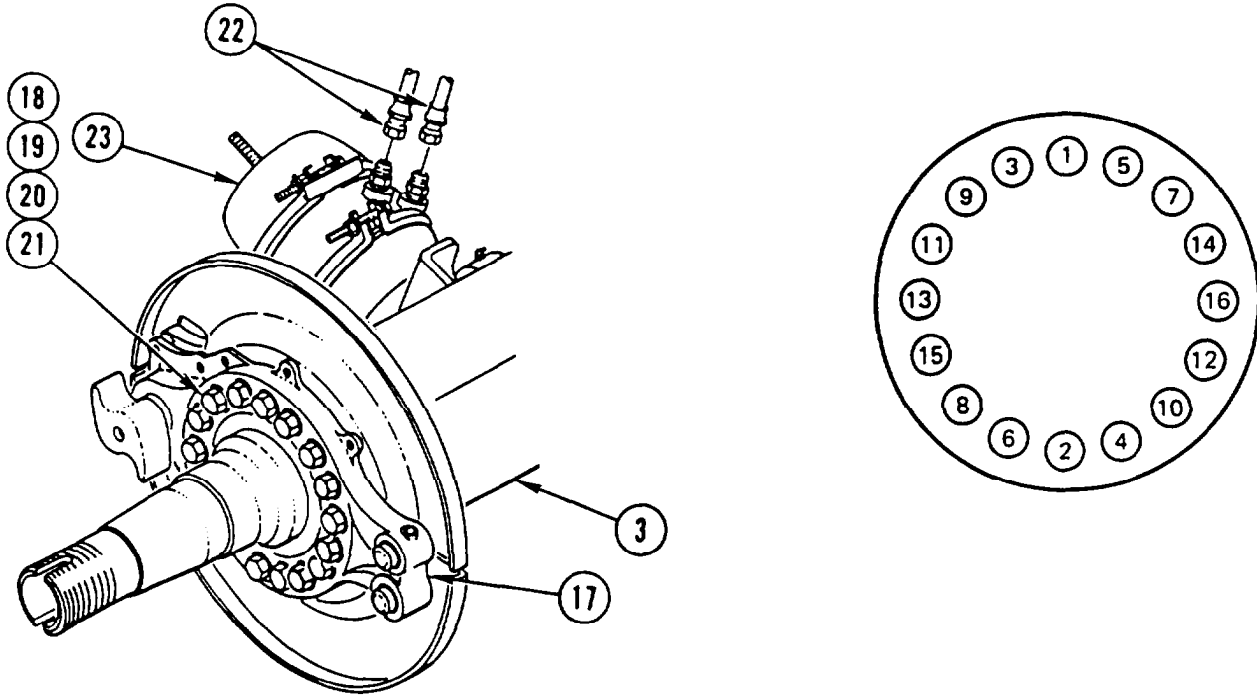

8. REPOSITION JACK STAND FROM STEP 4 OF REMOVAL AND INSTALL SPIDER ASSEMBLY (17), 16 WASHERS (18), 16 SCREWS (19), 16 WASHERS (20), AND 16 NUTS (21) ON FORWARD-REAR AXLE (3). TIGHTEN NUTS TO 150-175 LB-FT (203.4-237.3 N.m) IN SEQUENCE SHOWN.

WARNING

Make sure all air lines and fittings are clear of debris. Failure to do so could result in equipment failure and/or injury to personnel.

9. INSTALL TWO AIR HOSES (22) IN FORWARD-REAR BRAKE CHAMBER (23).
10. REPEAT STEPS 8 AND 9 FOR REAR AXLE.

NOTE

Follow-on Maintenance:
Install rear brakeshoe and linings (TM 9-2320-363-20).

CHAPTER 10
 BODY, CAB, HOOD, AND HULL MAINTENANCE

OVERVIEW

This chapter illustrates and describes procedures for maintenance of the body, cab, hood, and hull and related parts. A list of tasks contained in this chapter is shown below.

	Page
Seat Cover and Pad Repair	10-2
Dashboard Replacement	10-3
Air Ducts Replacement (M915A2 and M916A1)	10-36
Air Ducts Replacement (All Except M915A2 and M916A1)	10-39.0
Front Cab Mounts Replacement	10-40
Rear Cab Mounts Replacement	10-49
Windshield Replacement	10-52
Cab Replacement (M915A2)	10-64
Cab Replacement (All Except M915A2)	10-75
Rear Window Replacement	10-84
Cab Door Replacement	10-89

SEAT COVER AND PAD REPAIR

This task covers: Repair

INITIAL SETUP

Tools and Special Equipment:

Shop Equipment, SC 4910-95-CL-A31
Tool Kit, SC 5180-90-CL-N05

References:

FM 10-16
TM 9-2320-363-20

Equipment Condition:

Reference

TM 9-2320-363-20

Condition Description

Seat Cover and Pad
Removed

REPAIR

REPAIR SEAT COVER AND PAD IN ACCORDANCE WITH FM 10-16.

NOTE

Follow-on Maintenance:

Install seat cover and pad (TM 9-2320-363-20).

DASHBOARD REPLACEMENT

This task covers: a. Removal b. Cleaning c. Inspection d. Installation

INITIAL SETUP

Tools and Special Equipment:

Shop Equipment, SC 4910-95-CL-A31
 Tool Kit, SC 5180-90-CL-N05

Materials/Parts:

Nut, Lock (2) P/N 420Z
 Washer, Lock (4)
 Compound, Sealing Appendix B, Item 16
 Nut, Lock (13)

Personnel Required: (2)

References:

TM 9-2320-363-20

Equipment Condition:

Reference	Condition	Description
TM 9-2320-363-20	Batteries	Disconnected
TM 9-2320-363-20	Air System	Drained
TM 9-2320-363-20	Tachometer Cable	Removed
TM 9-2320-363-20	Speedometer Drive Shaft and Cable	Removed
TM 9-2320-363-20	Steering Wheel and Column	Removed
TM 9-2320-363-20	Air Cleaner, Pre-Cleaner, and Duct Assembly	Removed

DASHBOARD REPLACEMENT (CONT)

REMOVAL

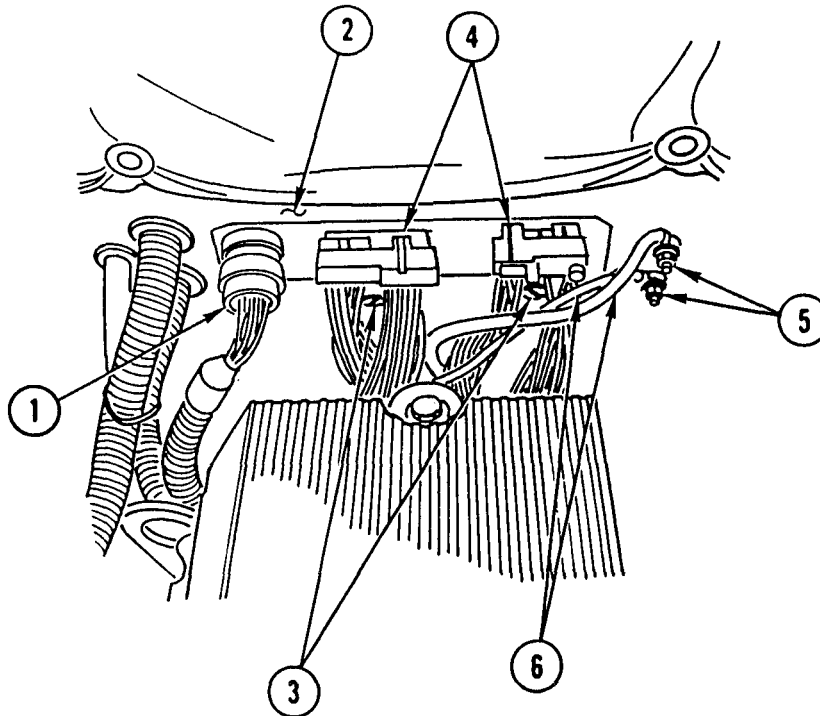

CAUTION

Make sure all connectors are properly tagged. Failure to do so could result in electrical damage to equipment.

NOTE

- Procedure is the same for both vehicles except as noted.
- Tag all connectors, cables, and air lines prior to removal to aid in installation.
- Quantity of tie wraps may vary from zero to several. Remove as necessary.

1. DISCONNECT CONNECTOR (1) FROM FIREWALL (2).
2. LOOSEN TWO SCREWS (3) AND DISCONNECT TWO CONNECTORS (4) FROM FIREWALL (2).
3. REMOVE TWO NUTS (5) AND DISCONNECT TWO CABLES (6).

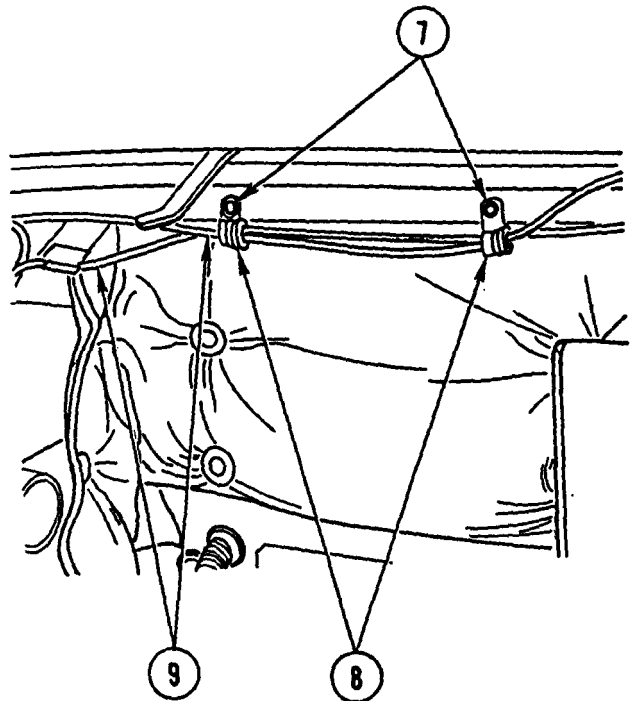

4. REMOVE TWO SCREWS (7) AND TWO CLAMPS (8) FROM TWO AIR LINES (9).

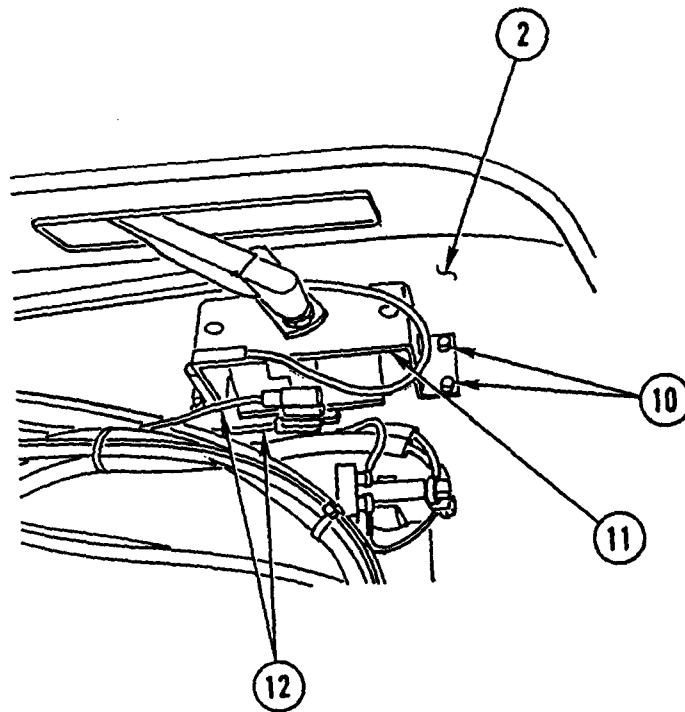

5. REMOVE FOUR SCREWS (10) AND PULL WINDSHIELD WIPER MOTOR (11) FAR ENOUGH AWAY FROM FIREWALL (2) TO REMOVE TWO AIR LINES (12).
6. INSTALL WINDSHIELD WIPER MOTOR (11) AND FOUR SCREWS (10) HAND-TIGHT.

DASHBOARD REPLACEMENT (CONT)

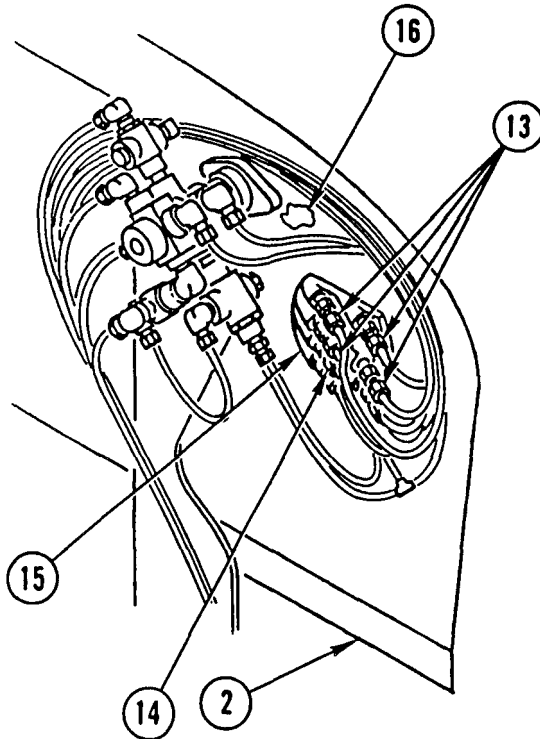

7. DISCONNECT SIX AIR LINES (13) AND OIL LINE (14) FROM JUNCTION BLOCK (15).
8. REMOVE SEALING COMPOUND (16) FROM FIREWALL (2).

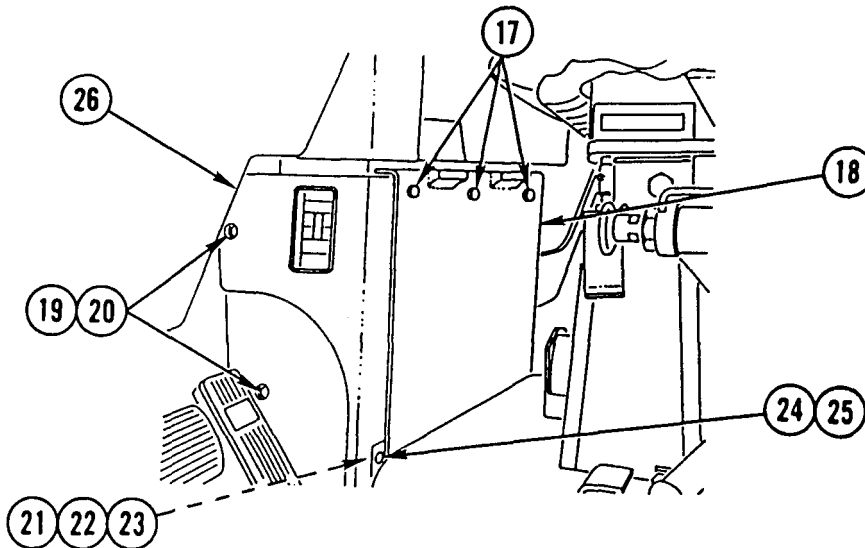

9. ROTATE THREE FASTENERS (17) TO LEFT AND REMOVE COVER (18).
10. REMOVE TWO SCREWS (19) AND TWO WASHERS (20).
11. REMOVE LOCK NUT (21), WASHER (22), SPACER (23), SCREW (24), WASHER (25), AND COVER (26). DISCARD LOCK NUT.

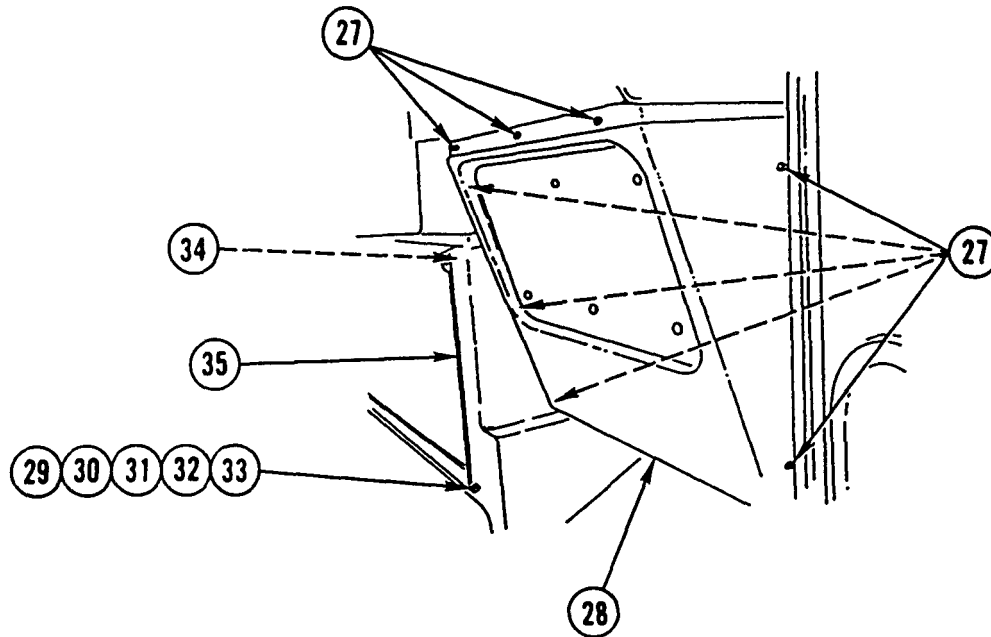

12. REMOVE NINE SELF-TAPPING SCREWS (27) AND COVER (28).

13. REMOVE LOCK NUT (29), WASHER (30), SCREW (31), WASHER (32), AND SPACER (33). DISCARD LOCK NUT.

14. REMOVE SCREW (34) AND COVER (35).

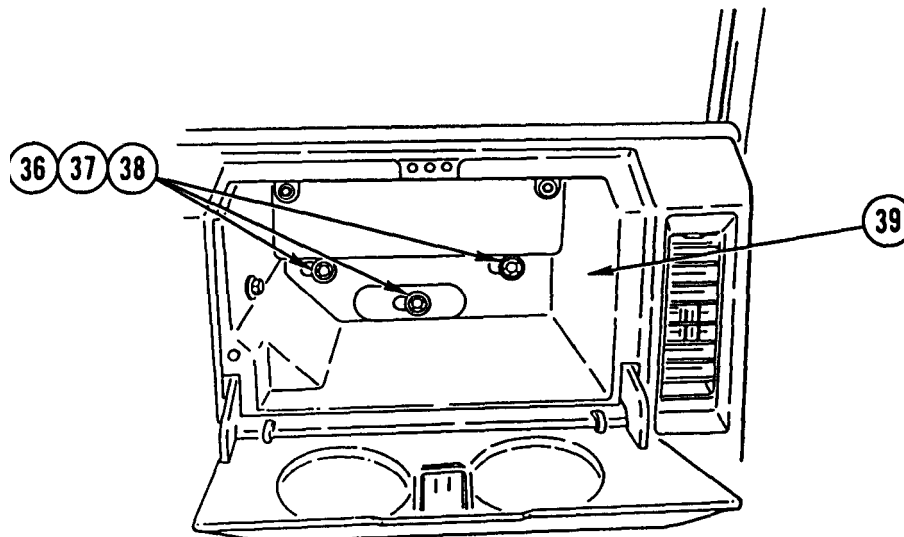

15. REMOVE THREE LOCK NUTS (36), THREE WASHERS (37), THREE INSERTS (38), AND COMPARTMENT (39). DISCARD LOCK NUTS.

DASHBOARD REPLACEMENT (CONT)

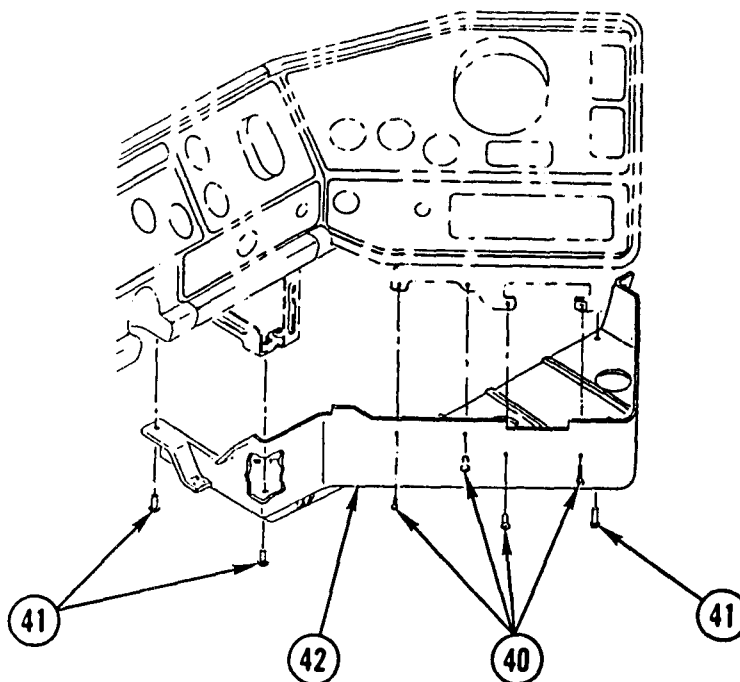

16. REMOVE FOUR SCREWS (40), THREE TORX SCREWS (41), AND LOWER PANEL (42).

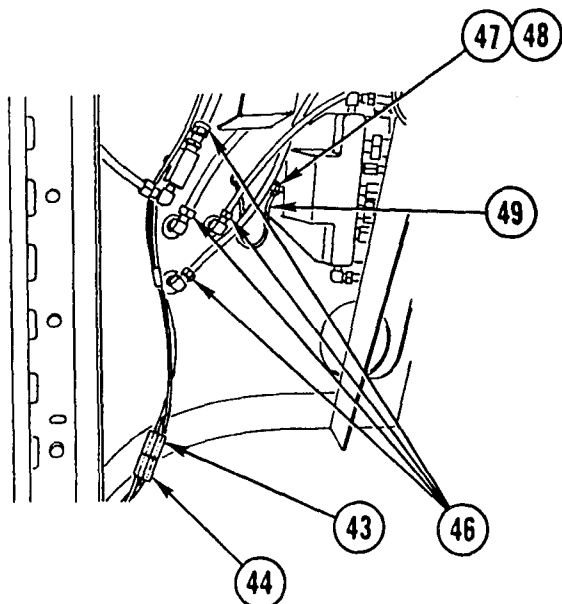

M915A2

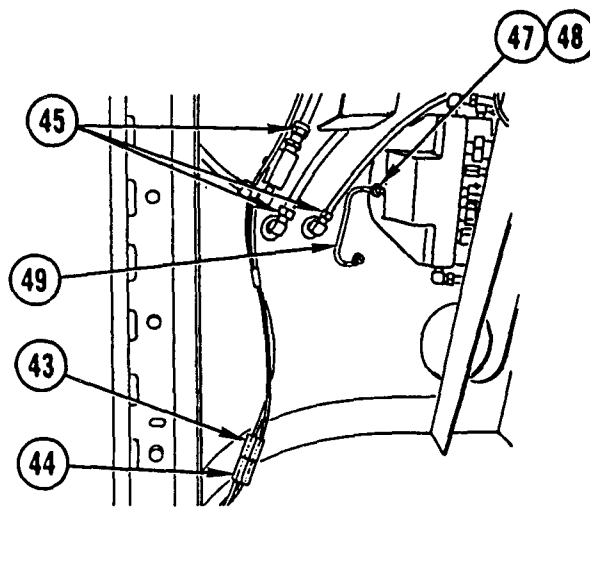

M916A1

17. DISCONNECT CONNECTOR (43) FROM SIDE MARKER LIGHT CONNECTOR (44).

NOTE

Perform step 18 on M916A1 only.

18. DISCONNECT THREE AIR LINES (45).

NOTE

Perform step 19 on M915A2 only.

19. DISCONNECT FOUR AIR LINES (46).
20. REMOVE LOCK NUT (47) AND WASHER (46) AND DISCONNECT GROUND CABLE (49). DISCARD LOCK NUT.

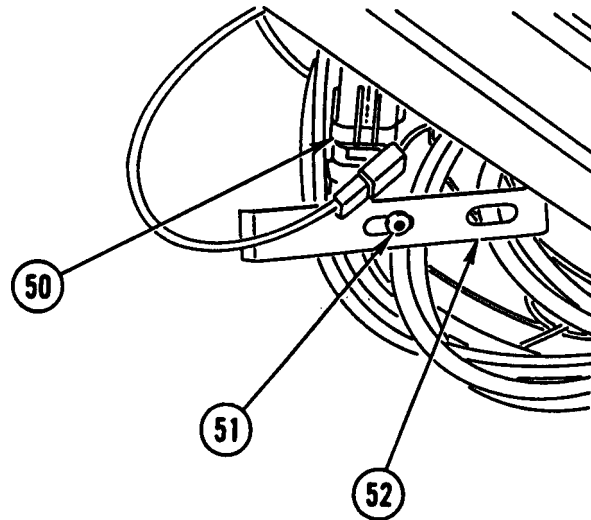

21. DISCONNECT ACCELERATOR CONNECTOR (50).
22. REMOVE TORX SCREW (51) AND RETAINER (52).

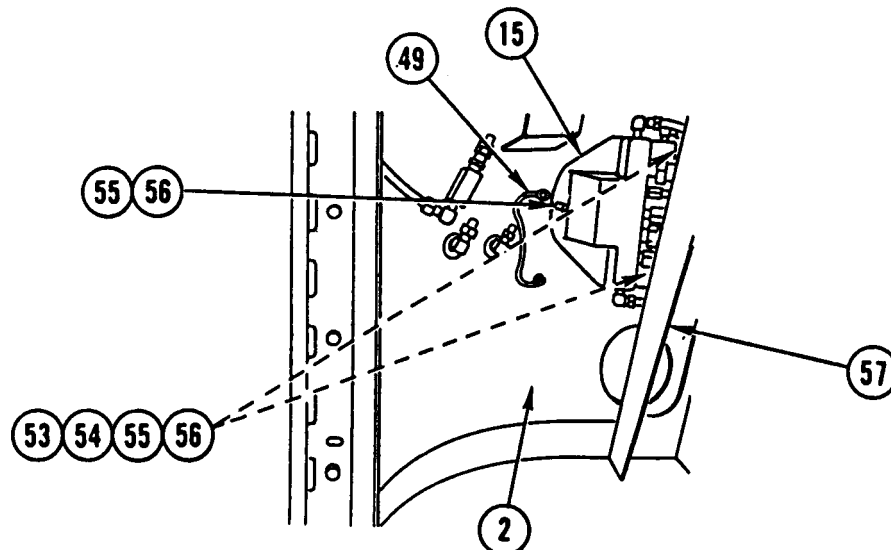

23. REMOVE TWO LOCK NUTS (53), TWO WASHERS (54), THREE CAPSCREWS (55), GROUND CABLE (49), THREE WASHERS (56), AND JUNCTION BLOCK (15) FROM FIREWALL (2). DISCARD LOCK NUTS.
24. CAREFULLY MOVE JUNCTION BLOCK (15) FROM BEHIND STEERING COLUMN BRACKET (57).

DASHBOARD REPLACEMENT (CONT)

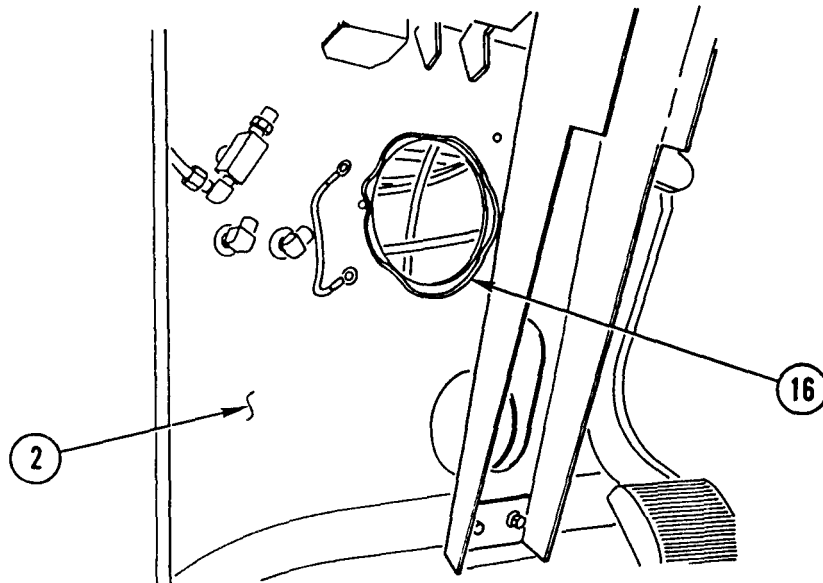

25. REMOVE SEALING COMPOUND (16) FROM FIREWALL (2).

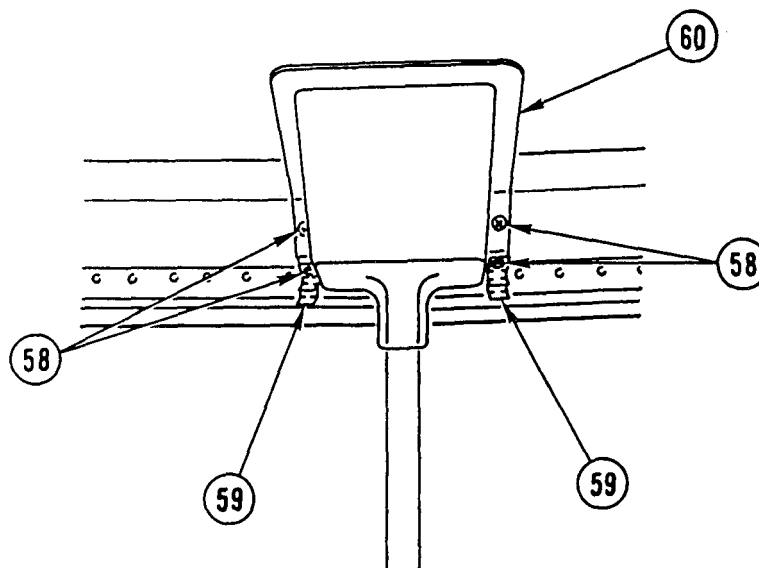

26. REMOVE FOUR TORX SCREWS (58), TWO BRACKETS (59), AND COVER (60).

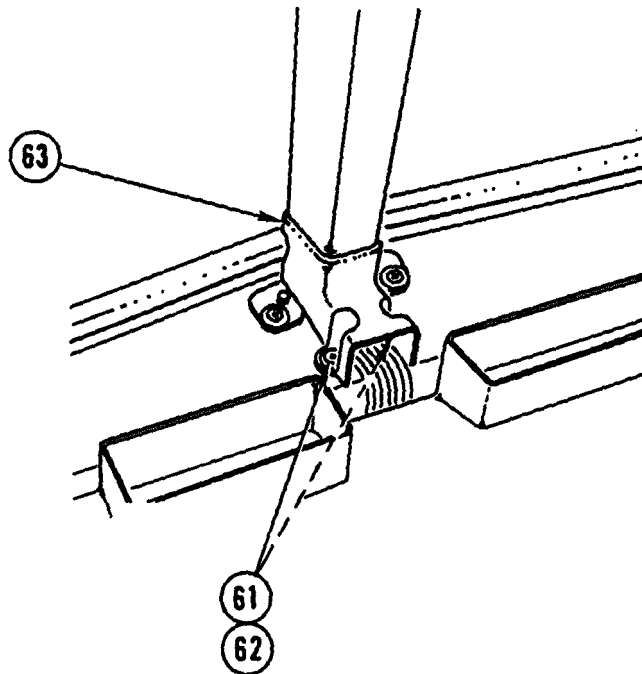

27. REMOVE TWO TORX SCREWS (61), TWO WASHERS (62), AND COVER (63).

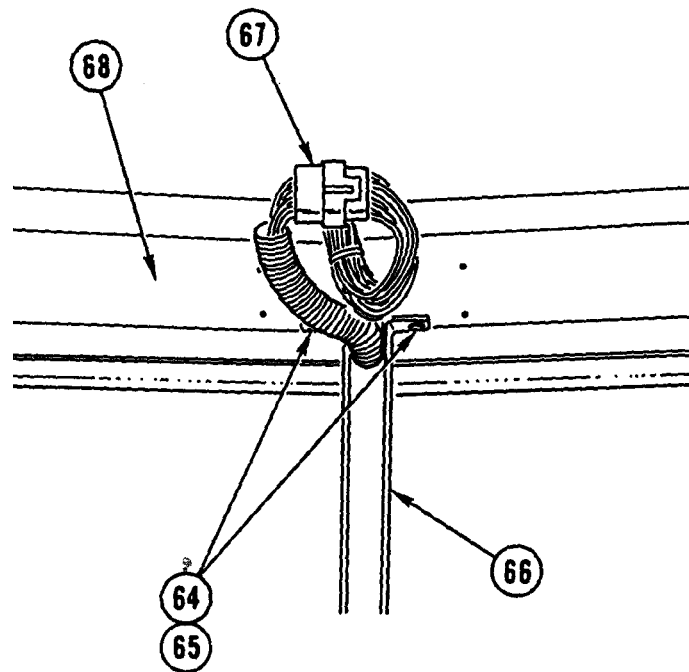

28. REMOVE FOUR SCREWS (64), FOUR WASHERS (65), AND WINDSHIELD SUPPORT (66).

29. DISCONNECT CONNECTOR (67) FROM CEILING (66).

DASHBOARD REPLACEMENT (CONT)

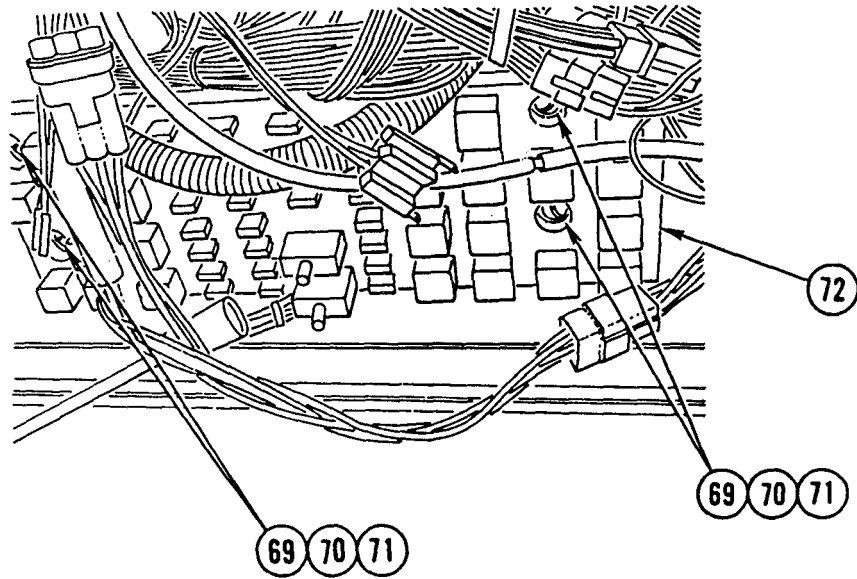

- 30. REMOVE FOUR CAPSCREWS (69), FOUR WASHERS (70), FOUR LOCK WASHERS (71), AND FUSE, RELAY, AND CIRCUIT BREAKER PANEL (72). SET FUSE, RELAY, AND CIRCUIT BREAKER PANEL (72) ASIDE. DISCARD LOCK WASHERS.

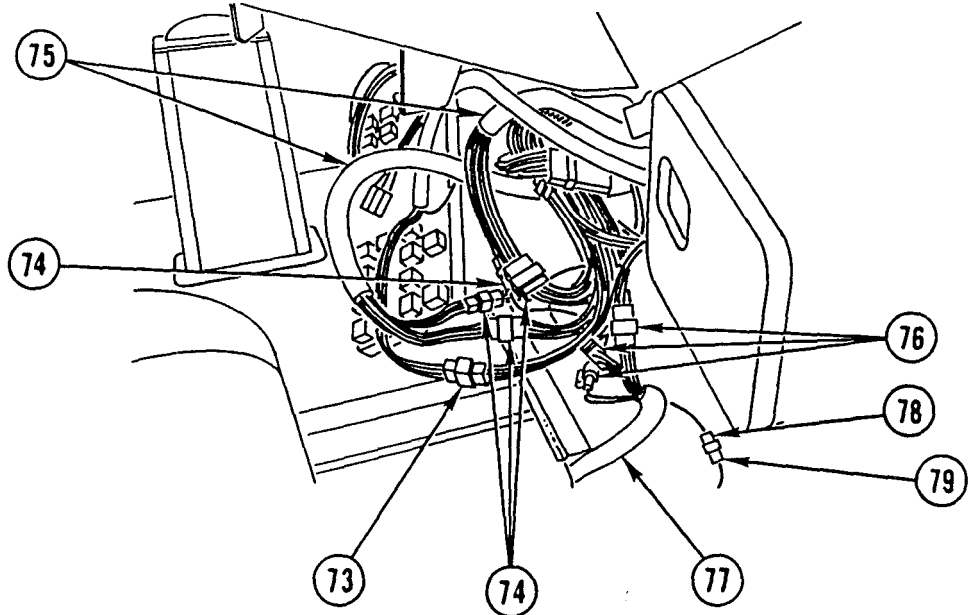

- 31. DISCONNECT TRAILER CONNECTOR (73).
- 32. DISCONNECT FOUR CONNECTORS (74) FROM CHASSIS WIRING HARNESS (75).
- 33. DISCONNECT THREE CONNECTORS (76) FROM ABS WIRING HARNESS (77).
- 34. DISCONNECT CONNECTOR (78) FROM TRANSMISSION SELECTOR LAMP CONNECTOR (79).

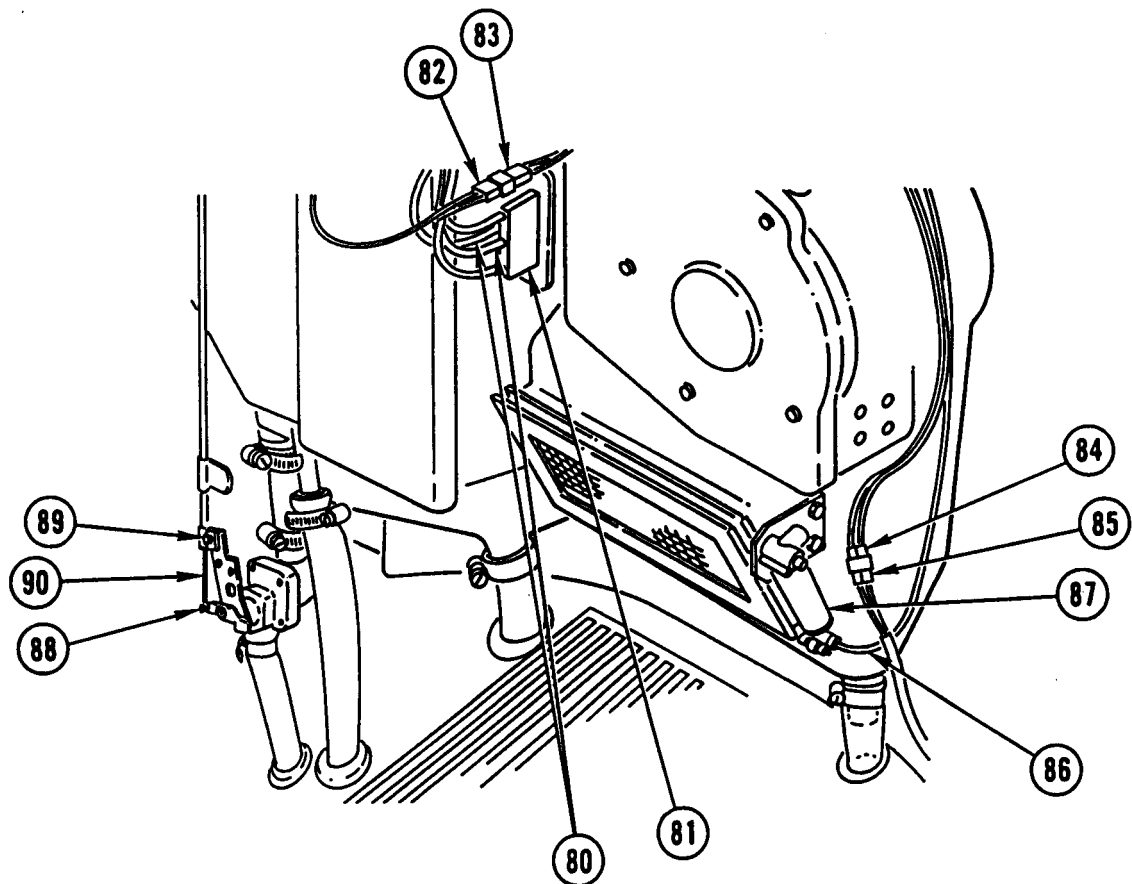

35. DISCONNECT TWO CONNECTORS (80) FROM HEATER RESISTOR BLOCK (81).
36. DISCONNECT CONNECTOR (82) FROM HEATER FAN MOTOR CONNECTOR (83).
37. DISCONNECT CONNECTOR (84) FROM SIDE MARKER LIGHT CONNECTOR (85).
38. DISCONNECT AIR LINE (86) FROM AIR CYLINDER (87).
39. REMOVE RETAINER (88) AND SCREW (89) AND DISCONNECT HEATER CONTROL CABLE (90).

DASHBOARD REPLACEMENT (CONT)

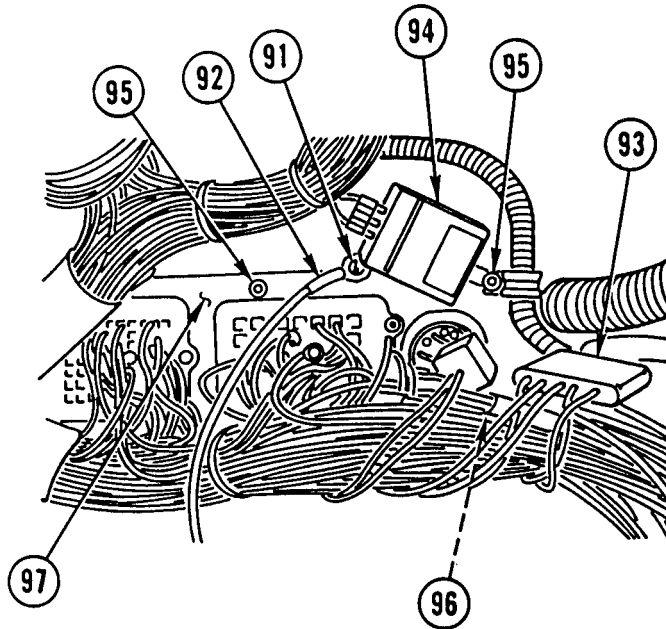

- 40. REMOVE SCREW (91) AND DISCONNECT GROUND CABLE (92).
- 41. DISCONNECT CONNECTOR (93) FROM LOW COOLANT MODULE (94).
- 42. REMOVE SIX TORX SCREWS (95), LOW COOLANT MODULE (94), THREE GROUND CABLES (96), AND CONNECTOR PANEL (97). SET CONNECTOR PANEL (97) ASIDE.

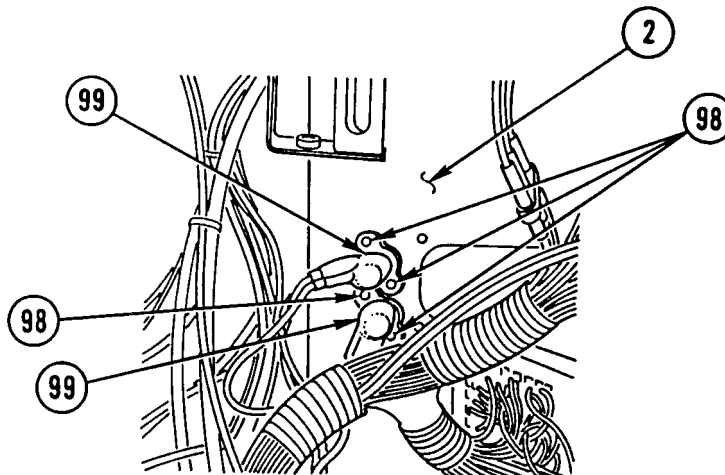

- 43. REMOVE FOUR SCREWS (98) AND TWO STUDS (99) FROM FIREWALL (2). SET STUDS (99) ASIDE.

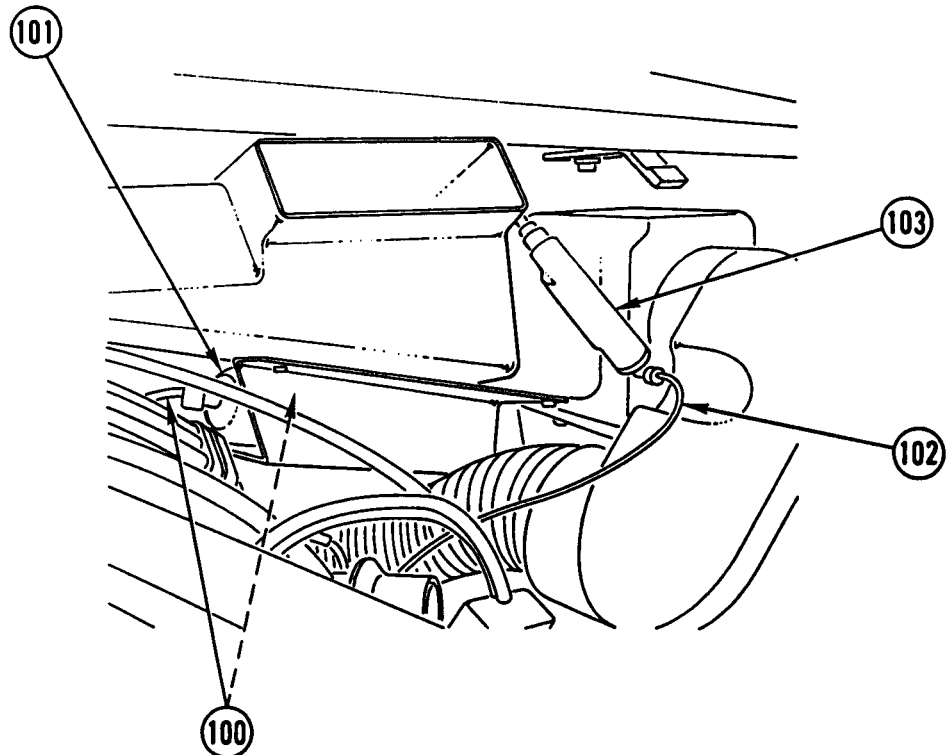

- 44. DISCONNECT TWO AIR LINES (100) FROM AIR CYLINDER (101).
- 45. DISCONNECT AIR LINE (102) FROM AIR CYLINDER (103).

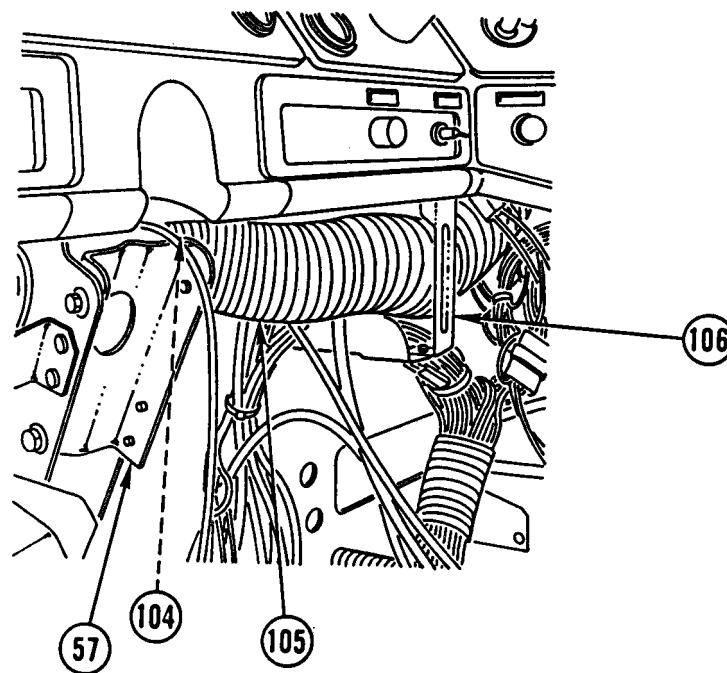

- 46. REMOVE TIE WRAP (104) AND DISCONNECT FLEX TUBE (105) FROM STEERING COLUMN BRACKET (57).
- 47. CAREFULLY REMOVE FLEX TUBE (105) FROM BRACKET (106).

DASHBOARD REPLACEMENT (CONT)

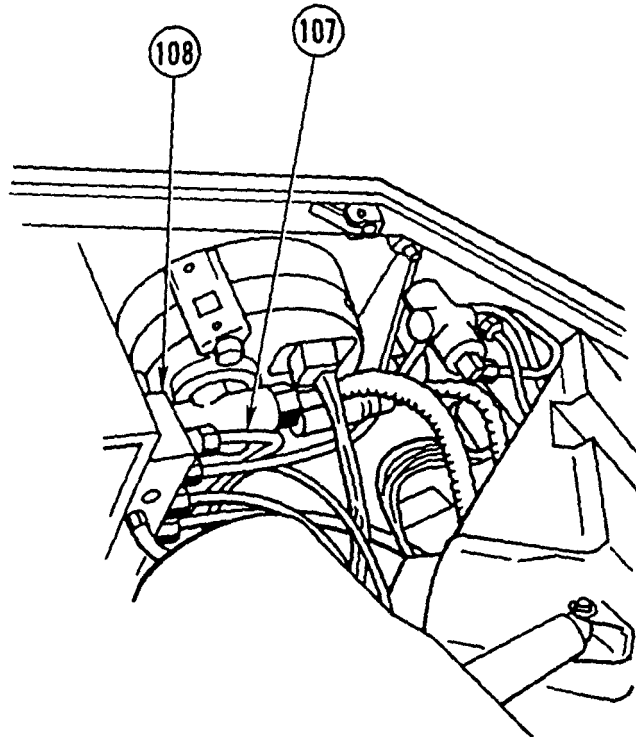

NOTE

Perform step 48 on M916A1 only.

48. DISCONNECT AIR LINE (107) FROM AIR JUNCTION BLOCK (108).

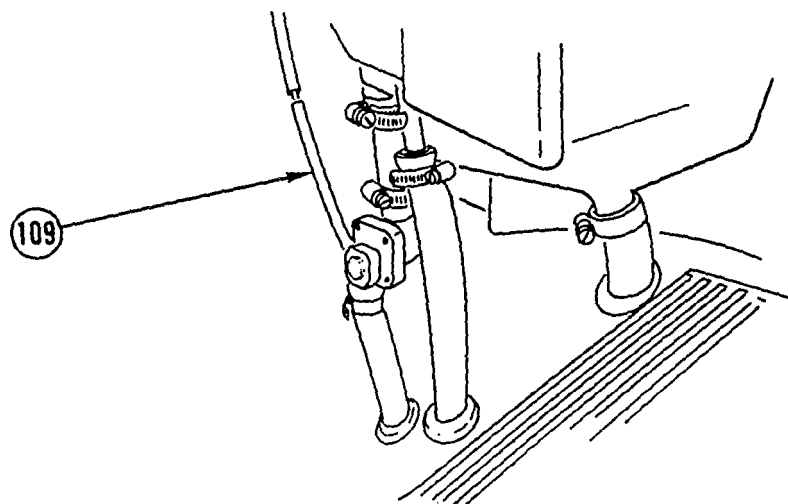

49. DISCONNECT WINDSHIELD WASHER AIR PRESSURE LINE (109).

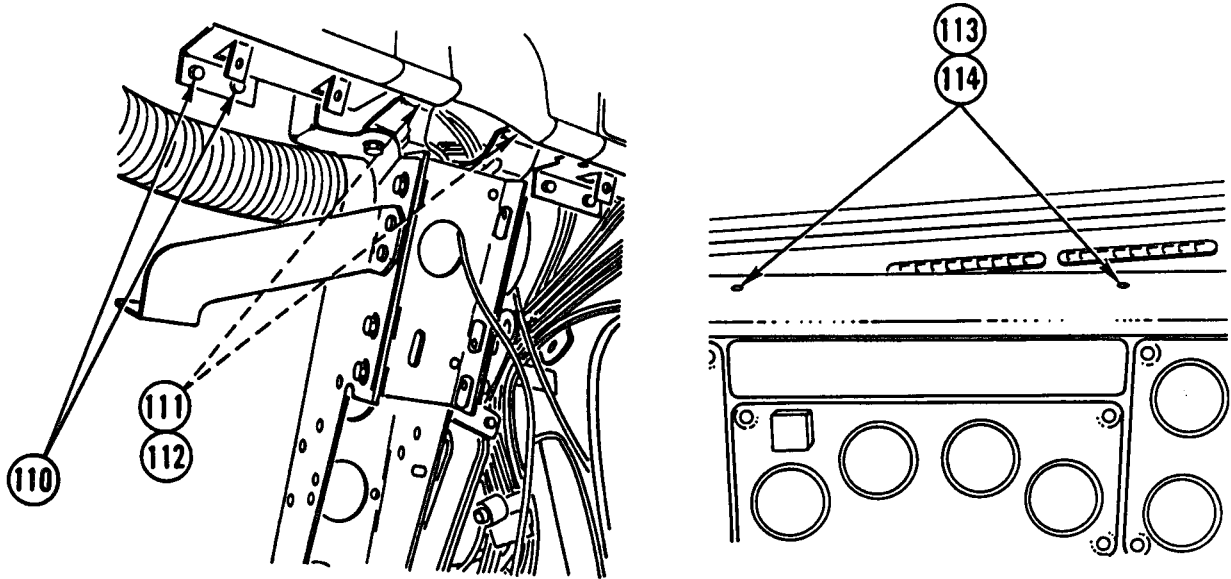

50. REMOVE TWO SCREWS (110).

51. REMOVE TWO NUTS (111), TWO WASHERS (112), TWO TORX SCREWS (113), AND TWO WASHERS (114).

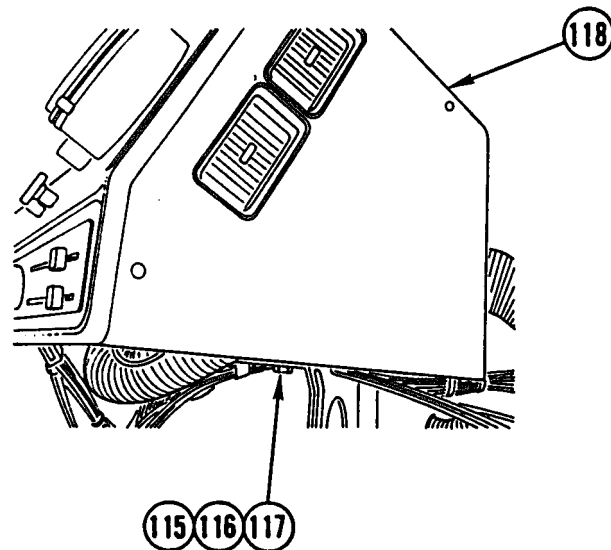

CAUTION

When performing step 52, use extreme caution to prevent damaging wiring harnesses and/or other items in dashboard assembly.

NOTE

Tag location of all lines removed thru firewall with dashboard assembly to aid in installation.

52. REMOVE NUT (115), TWO WASHERS (116), SCREW (117), AND DASHBOARD ASSEMBLY (118).

DASHBOARD REPLACEMENT (CONT)

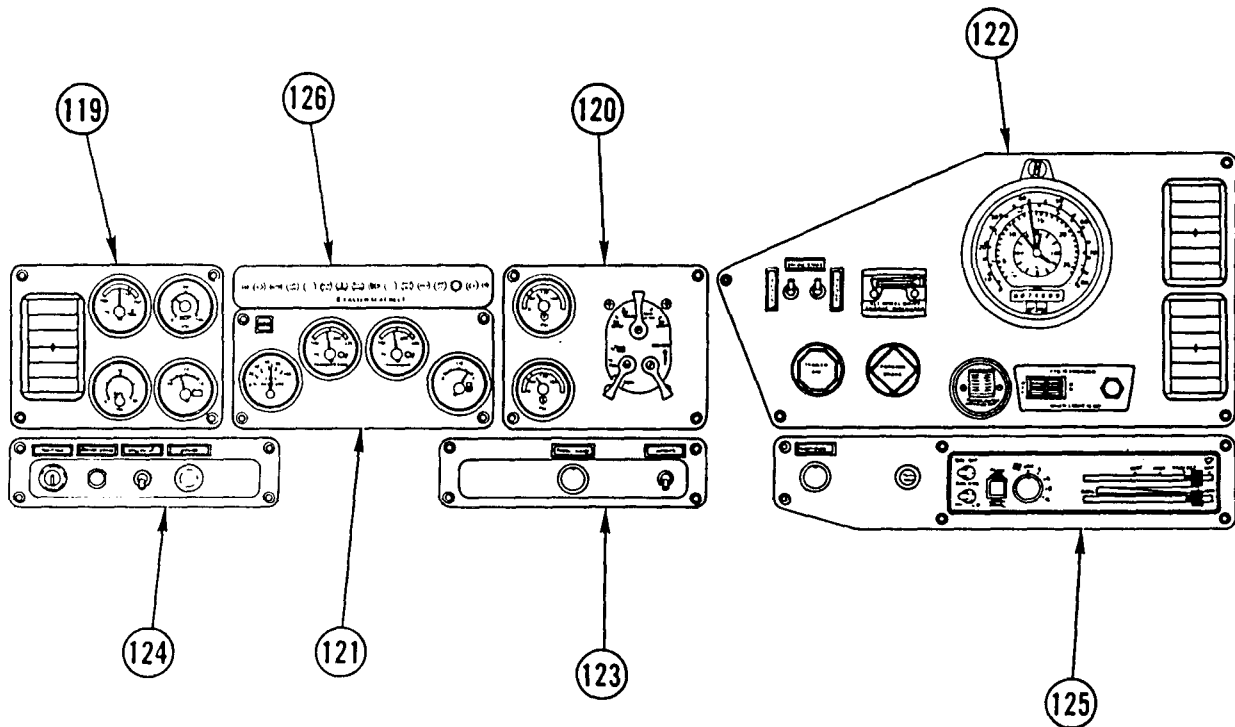

53. REMOVE LEFT GAGE PANEL (119) IN ACCORDANCE WITH REMOVAL, LEFT GAGE PANEL REPLACEMENT, TM 9-2320-363-20.
54. REMOVE RIGHT GAGE PANEL (120) IN ACCORDANCE WITH REMOVAL, RIGHT GAGE PANEL REPLACEMENT, TM 9-2320-363-20.
55. REMOVE CENTER GAGE PANEL (121) IN ACCORDANCE WITH REMOVAL, CENTER GAGE PANEL REPLACEMENT, TM 9-2320-363-20.
56. REMOVE TACHOGRAPH PANEL (122) IN ACCORDANCE WITH REMOVAL, TACHOGRAPH PANEL, REPLACEMENT, TM 9-2320-363-20.
57. REMOVE RIGHT-HAND SWITCH PANEL (123) IN ACCORDANCE WITH REMOVAL, RIGHT-HAND SWITCH PANEL REPLACEMENT, TM 9-2320-363-20.
58. REMOVE LEFT-HAND SWITCH PANEL (124) IN ACCORDANCE WITH REMOVAL, LEFT-HAND SWITCH PANEL REPLACEMENT, TM 9-2320-363-20.
59. REMOVE HEATER CONTROL PANEL (125) IN ACCORDANCE WITH REMOVAL, HEATER CONTROL PANEL REPLACEMENT, TM 9-2320-363-20.
60. REMOVE CONTROL MODULE (126) IN ACCORDANCE WITH REMOVAL, CONTROL MODULE REPLACEMENT, TM 9-2320-363-20.

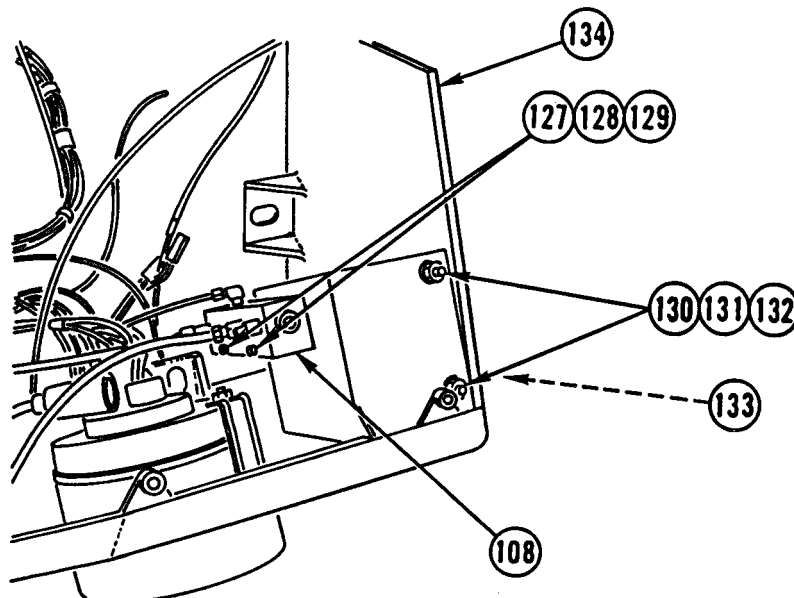

61. REMOVE TWO LOCK NUTS (127), TWO SCREWS (128), TWO WASHERS (129), AND AIR JUNCTION BLOCK (108). DISCARD LOCK NUTS.
62. REMOVE TWO LOCK NUTS (130), TWO SCREWS (131), TWO WASHERS (132), SCREW (133), AND RIGHT END PANEL (134). DISCARD LOCK NUTS.

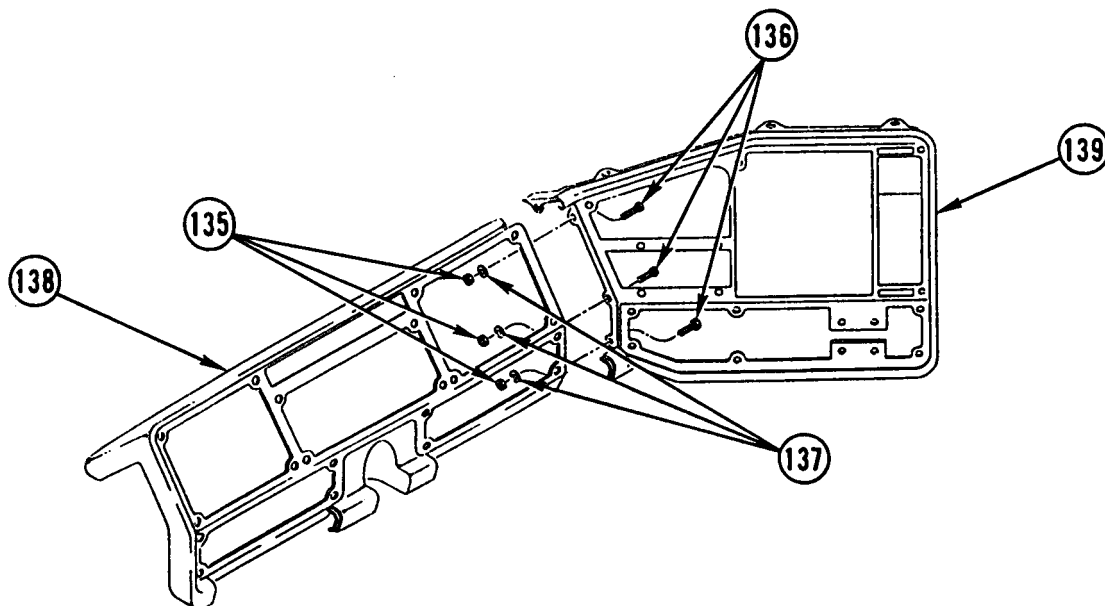

63. REMOVE THREE LOCK NUTS (135), THREE SCREWS (136), AND THREE WASHERS (137) THAT JOIN LEFT DASHBOARD (138) TO RIGHT DASHBOARD (139). DISCARD LOCK NUTS.

CLEANING

Use general cleaning methods to clean all parts (page 2-30).

DASHBOARD REPLACEMENT (CONT)

INSPECTION

Inspect all parts for wear or damage.

INSTALLATION

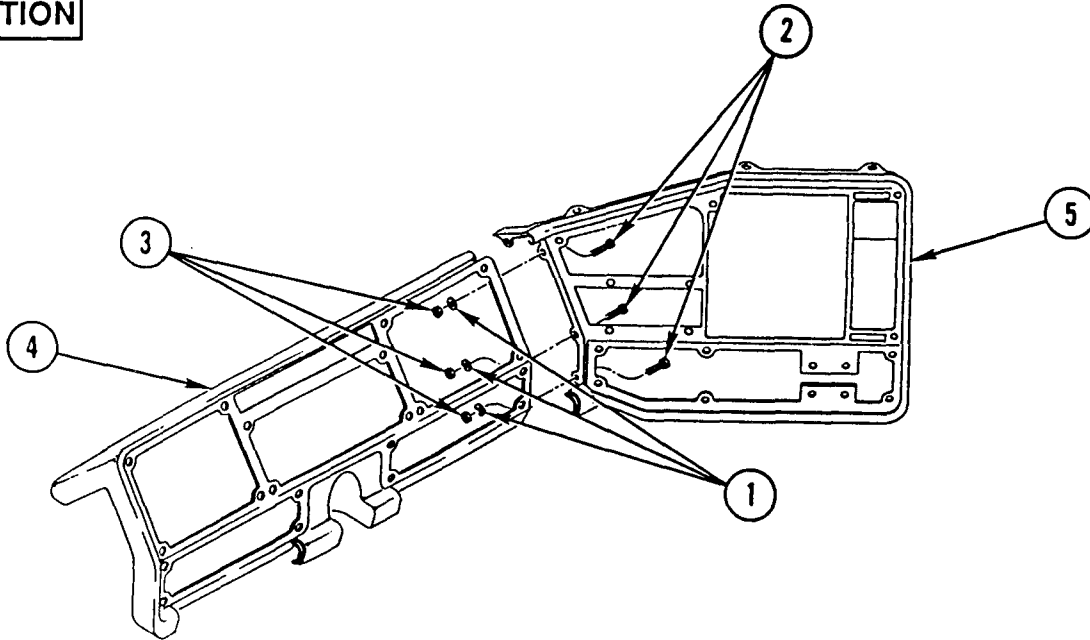

NOTE

- Procedure is the same for both vehicles except as noted.
- Quantity of tie wraps may vary from zero to several. Install as necessary.

1. INSTALL THREE WASHERS (1), THREE SCREWS (2), AND THREE NEW LOCK NUTS (3) THAT JOIN LEFT DASHBOARD (4) TO RIGHT DASHBOARD (5).

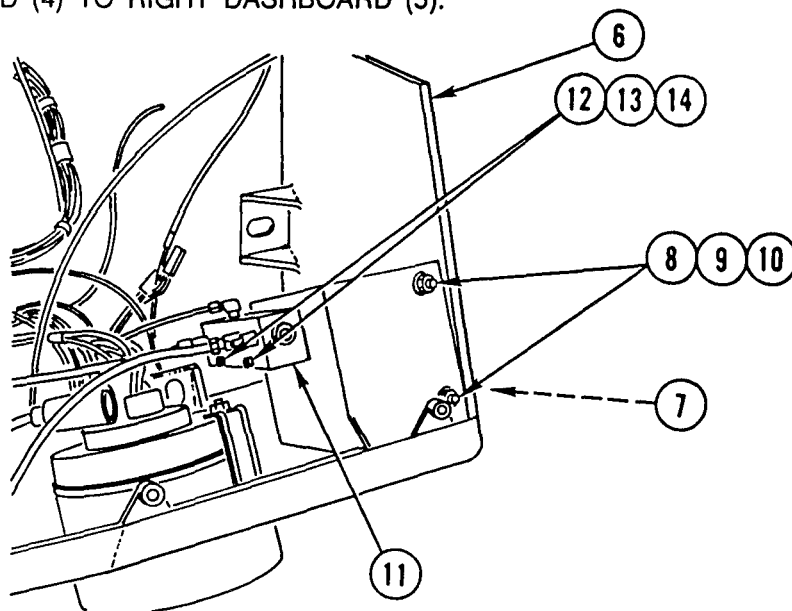

2. INSTALL RIGHT END PANEL (6), SCREW (7), TWO WASHERS (8), TWO SCREWS (9), AND TWO NEW LOCK NUTS (10).
3. INSTALL AIR JUNCTION BLOCK (11), TWO WASHERS (12), TWO SCREWS (13), AND TWO NEW LOCK NUTS (14).

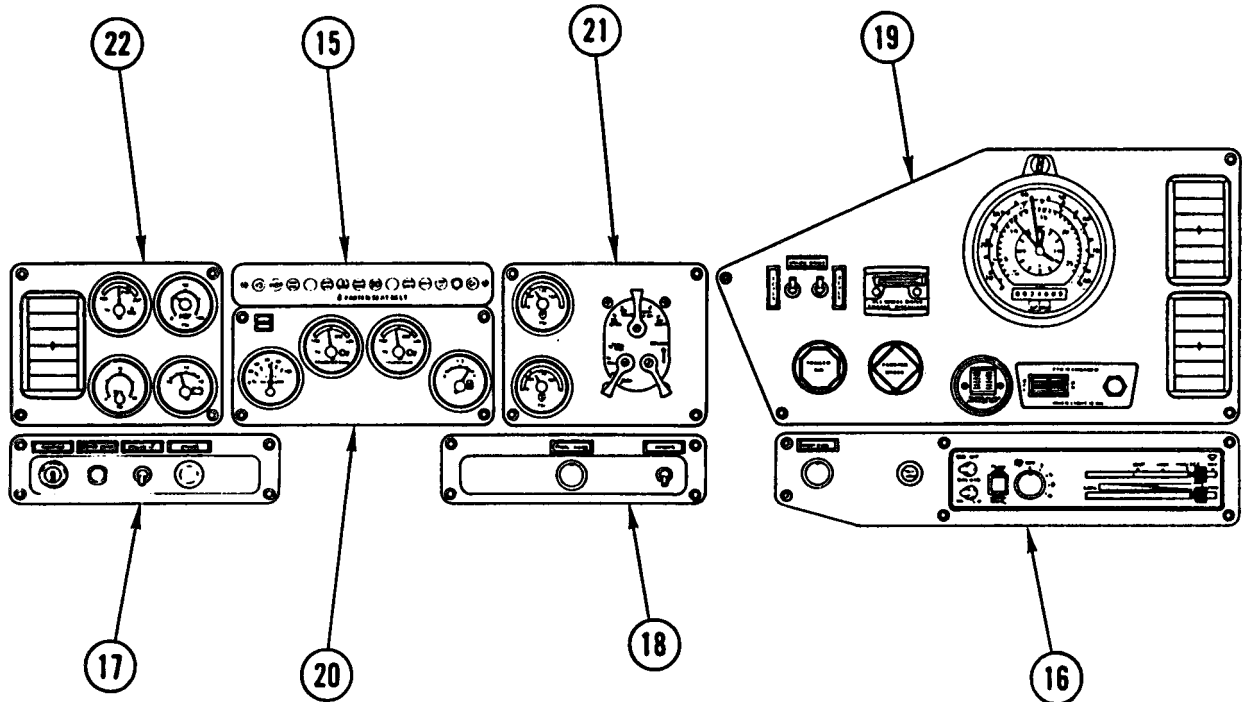

4. INSTALL CONTROL MODULE (15) IN ACCORDANCE WITH INSTALLATION, CONTROL MODULE REPLACEMENT, TM 9-2320-363-20.
5. INSTALL HEATER CONTROL PANEL (16) IN ACCORDANCE WITH INSTALLATION, HEATER CONTROL PANEL REPLACEMENT, TM 9-2320-363-20.
6. INSTALL LEFT-HAND SWITCH PANEL (17) IN ACCORDANCE WITH INSTALLATION, LEFT-HAND SWITCH PANEL REPLACEMENT, TM 9-2320-363-20.
7. INSTALL RIGHT-HAND SWITCH PANEL (18) IN ACCORDANCE WITH INSTALLATION, RIGHT-HAND SWITCH PANEL REPLACEMENT, TM 9-2320-363-20.
8. INSTALL TACHOGRAPH PANEL (19) IN ACCORDANCE WITH INSTALLATION, TACHOGRAPH PANEL REPLACEMENT, TM 9-2320-363-20.
9. INSTALL CENTER GAGE PANEL (20) IN ACCORDANCE WITH INSTALLATION, CENTER GAGE PANEL REPLACEMENT, TM 9-2320-363-20.
10. INSTALL RIGHT GAGE PANEL (21) IN ACCORDANCE WITH INSTALLATION, RIGHT GAGE PANEL REPLACEMENT, TM 9-2320-363-20.
11. INSTALL LEFT GAGE PANEL (22) IN ACCORDANCE WITH INSTALLATION, LEFT GAGE PANEL REPLACEMENT, TM 9-2320-363-20.

DASHBOARD REPLACEMENT (CONT)

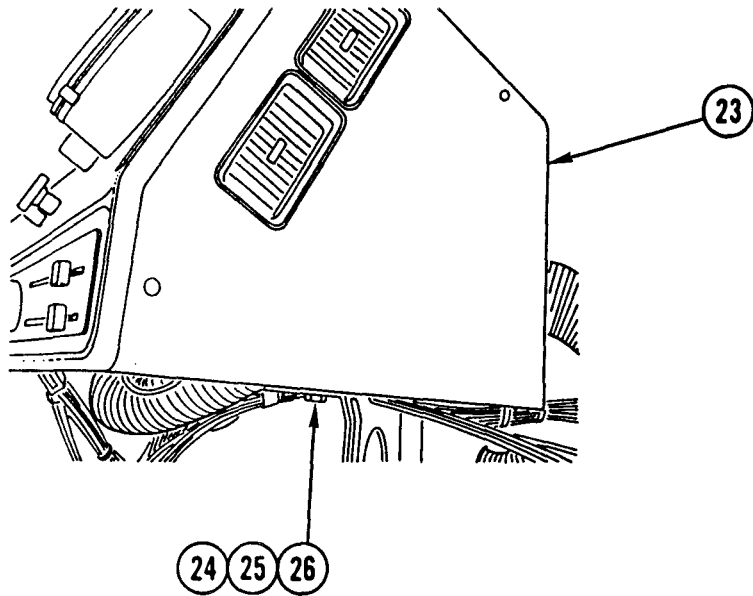

CAUTION

When performing step 12, use extreme caution to prevent damaging wiring harnesses and/or other items in dashboard assembly.

12. INSTALL DASHBOARD ASSEMBLY (23), SCREW (24), TWO WASHERS (25), AND NUT (26).

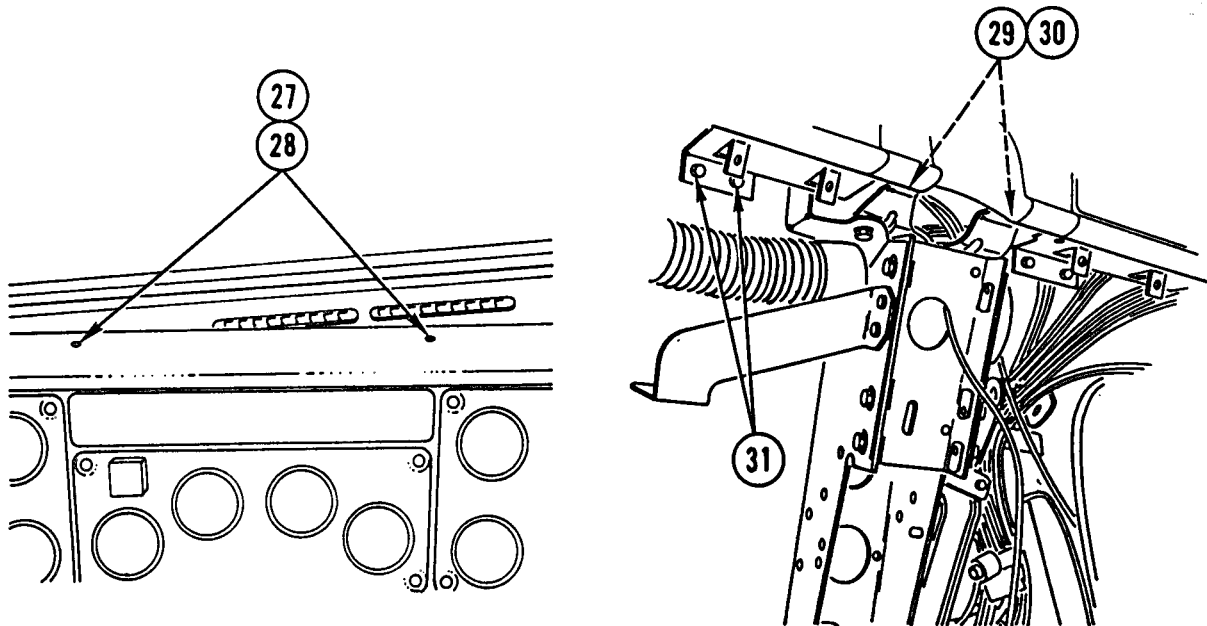

13. INSTALL TWO WASHERS (27), TWO TORX SCREWS (23), TWO WASHERS (29), AND TWO NUTS (30).

14. INSTALL TWO SCREWS (31).

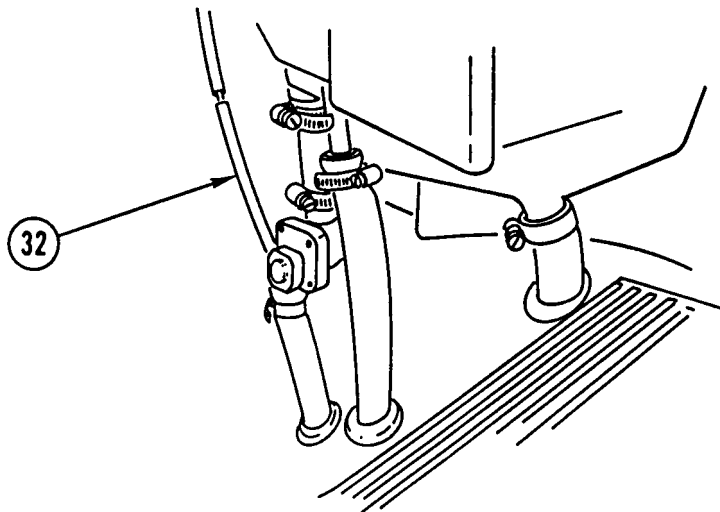

15. CONNECT WINDSHIELD WASHER AIR PRESSURE LINE (32).

DASHBOARD REPLACEMENT (CONT)

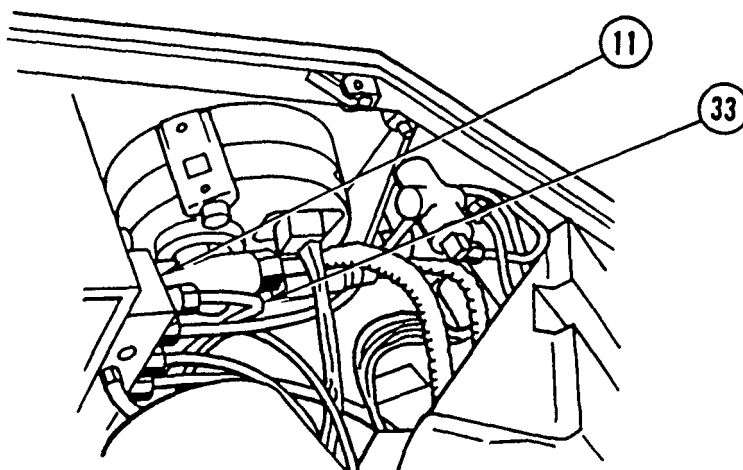

NOTE

Perform step 16 on M916A1 only.

16. CONNECT AIR LINE (33) TO AIR JUNCTION BLOCK (11).

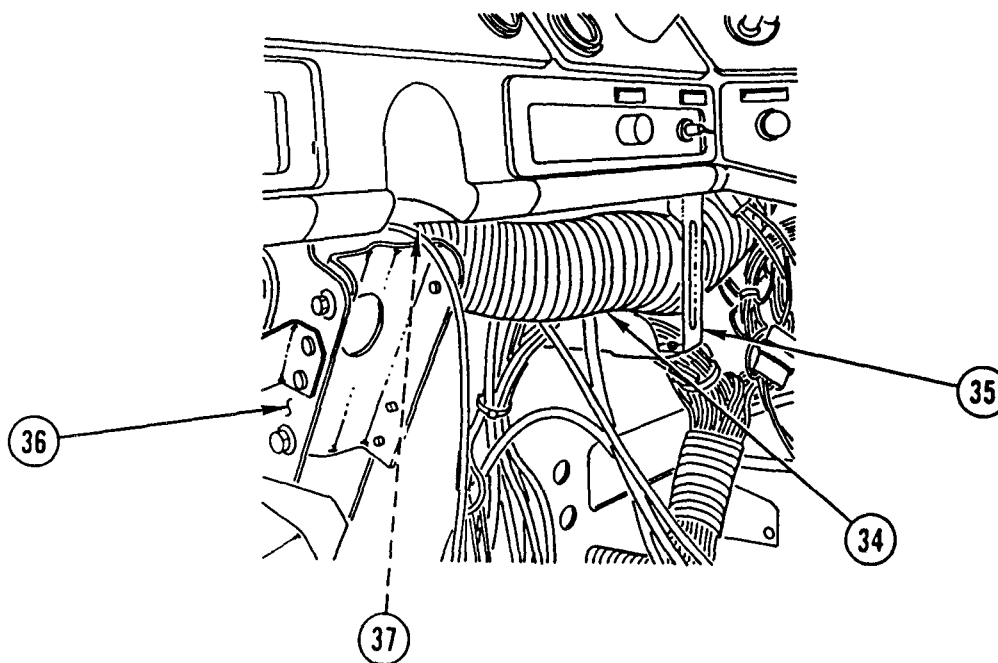

17. CAREFULLY INSTALL FLEX TUBE (34) THRU BRACKET (35).
18. CONNECT FLEX TUBE (34) TO STEERING COLUMN BRACKET (36) AND INSTALL TIE WRAP (37).

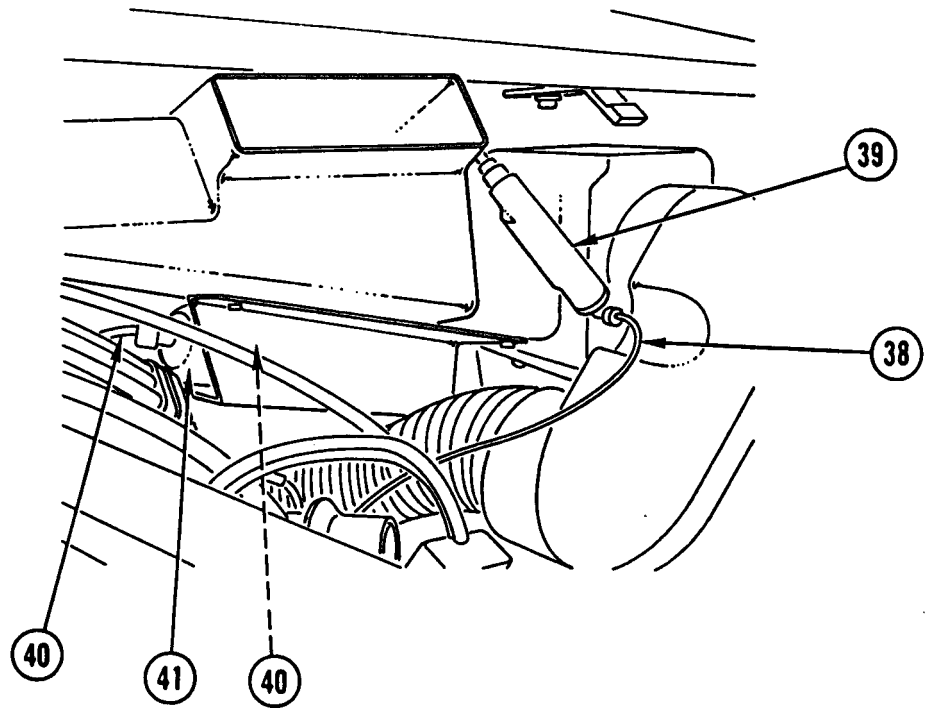

19. CONNECT AIR LINE (38) TO AIR CYLINDER (39).

20. CONNECT TWO AIR LINES (40) TO AIR CYLINDER (41).

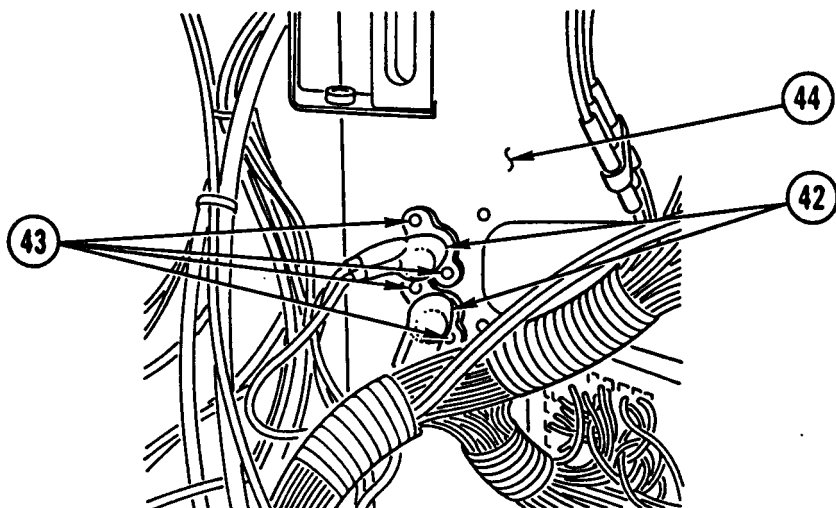

21. INSTALL TWO STUDS (42) AND FOUR SCREWS (43) IN FIREWALL (44).

DASHBOARD REPLACEMENT (CONT)

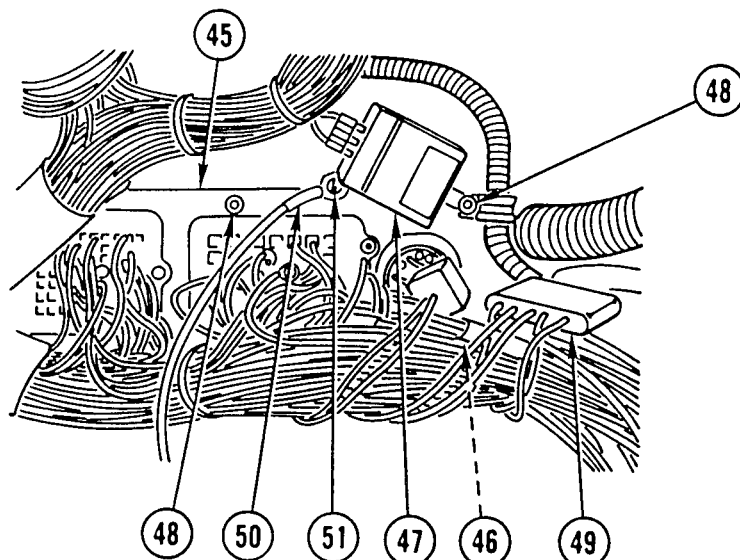

- 22. INSTALL CONNECTOR PANEL (45), THREE GROUND CABLES (46), LOW COOLANT MODULE (47), AND SIX TORX SCREWS (48).
- 23. CONNECT CONNECTOR (49) TO LOW COOLANT MODULE (47).
- 24. CONNECT GROUND CABLE (50) AND INSTALL SCREW (51).

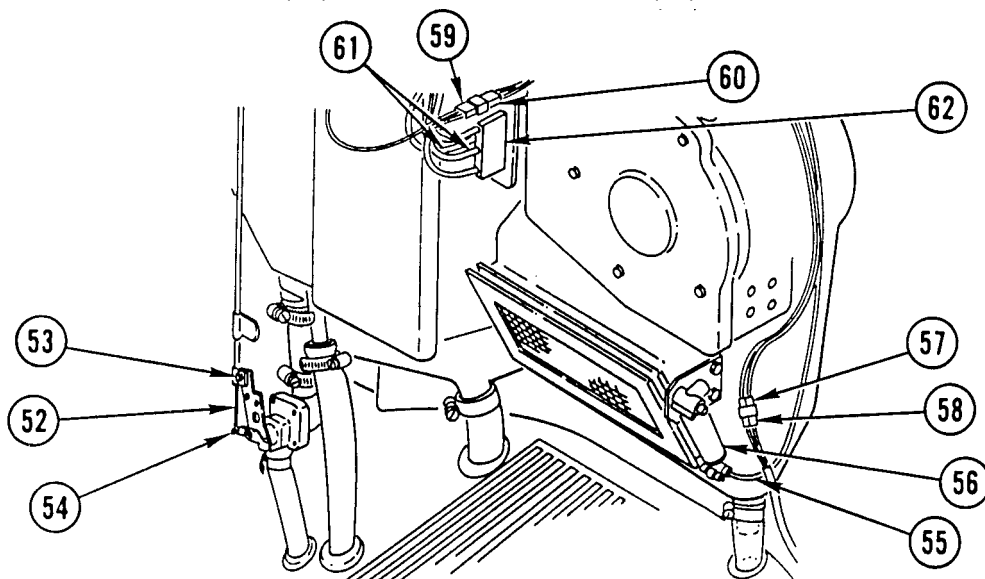

- 25. CONNECT HEATER CONTROL CABLE (52) AND INSTALL SCREW (53) AND RETAINER (54).
- 26. CONNECT AIR LINE (55) TO AIR CYLINDER (56).
- 27. CONNECT CONNECTOR (57) TO SIDE MARKER LIGHT CONNECTOR (58).
- 28. CONNECT CONNECTOR (59) TO HEATER FAN MOTOR CONNECTOR (60).
- 29. CONNECT TWO CONNECTORS (61) TO HEATER RESISTOR BLOCK (62).

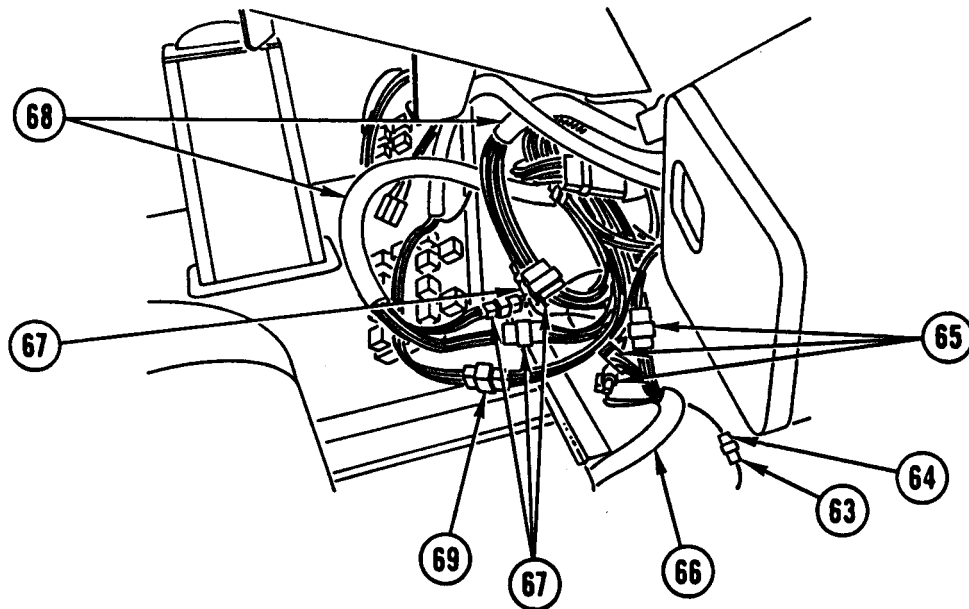

30. CONNECT TRANSMISSION SELECTOR LAMP CONNECTOR (63) TO LAMP CONNECTOR (64).
31. CONNECT THREE CONNECTORS (65) TO ABS WIRING HARNESS (66).
32. CONNECT FOUR CONNECTORS (67) TO CHASSIS WIRING HARNESS (66).
33. CONNECT TRAILER CONNECTOR (69).

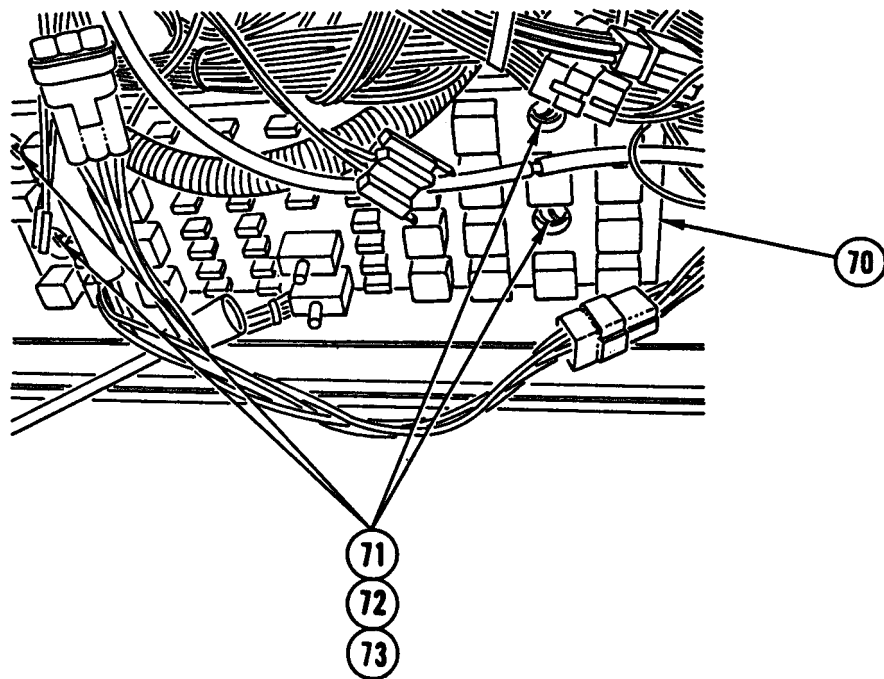

34. INSTALL FUSE, RELAY, AND CIRCUIT BREAKER PANEL (70), FOUR NEW LOCK WASHERS (71), FOUR WASHERS (72), AND FOUR CAPSCREWS (73).

DASHBOARD REPLACEMENT (CONT)

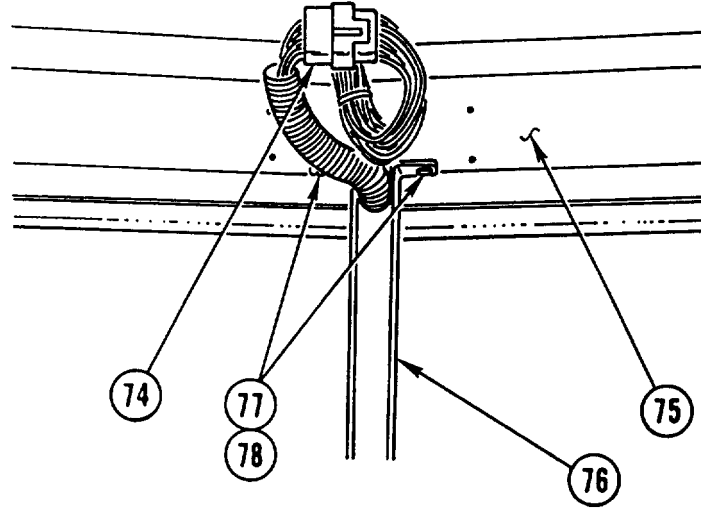

35. CONNECT CONNECTOR (74) TO CEILING (75).
36. INSTALL WINDSHIELD SUPPORT (76), FOUR WASHERS (77), AND FOUR SCREWS (78).

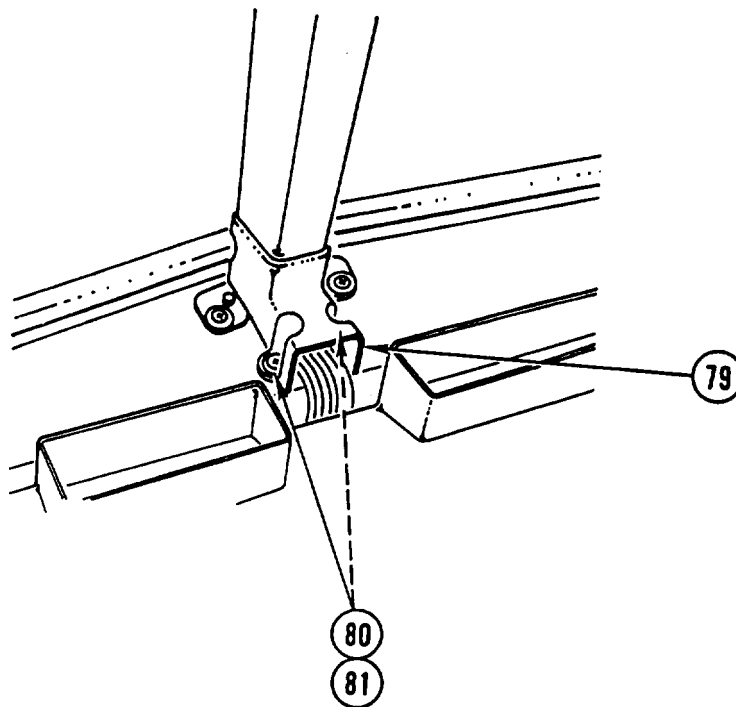

37. INSTALL COVER (79), TWO WASHERS (80), AND TWO TORX SCREWS (81).

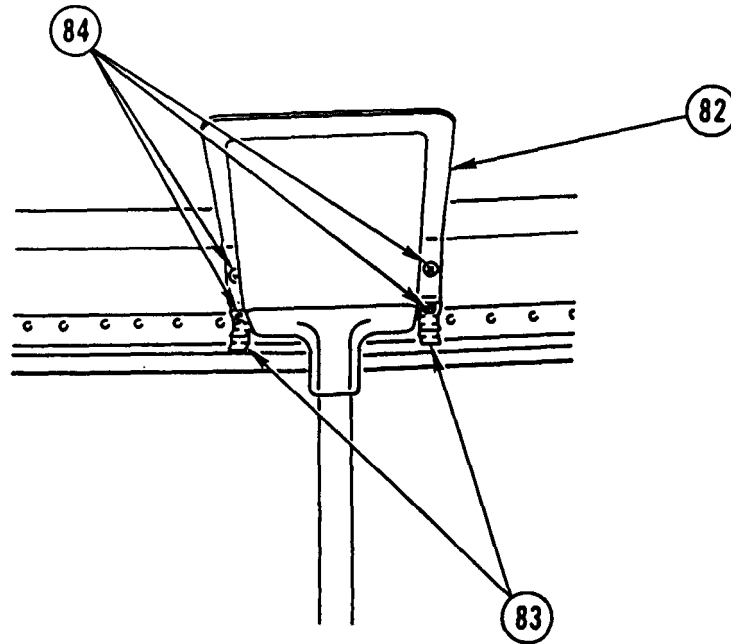

38. INSTALL COVER (82), TWO BRACKETS (83), AND FOUR TORX SCREWS (84).

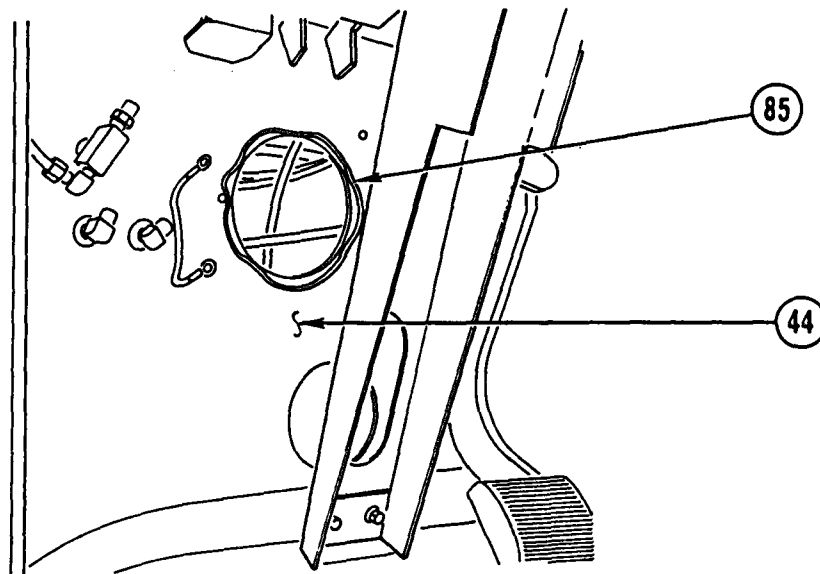

NOTE

Make sure all old sealing compound has been removed from firewall before applying new sealing compound.

39. APPLY NEW SEALING COMPOUND (85) ON FIREWALL (44).

DASHBOARD REPLACEMENT (CONT)

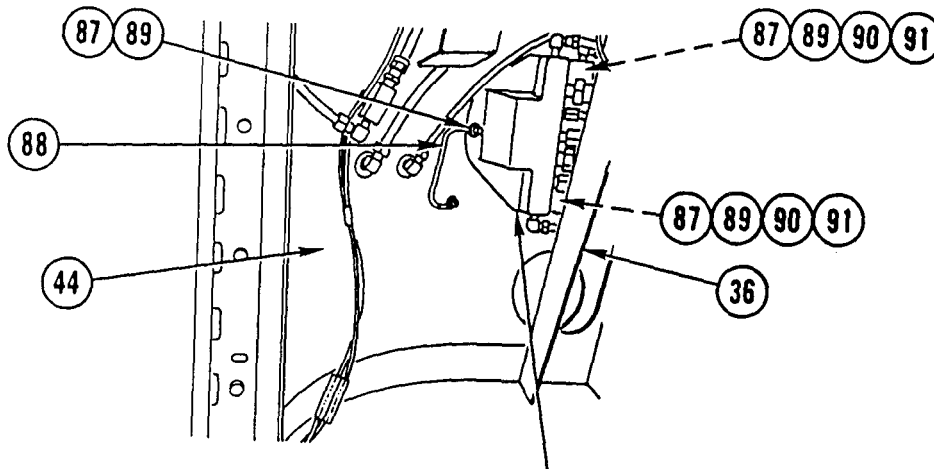

40. CAREFULLY MOVE JUNCTION BLOCK (86) INTO POSITION BEHIND STEERING COLUMN BRACKET (36).
41. INSTALL JUNCTION BLOCK (86), THREE WASHERS (87), GROUND CABLE (88), THREE CAPSCREWS (89), TWO WASHERS (90), AND TWO NEW LOCK NUTS (91) IN FIREWALL (44).

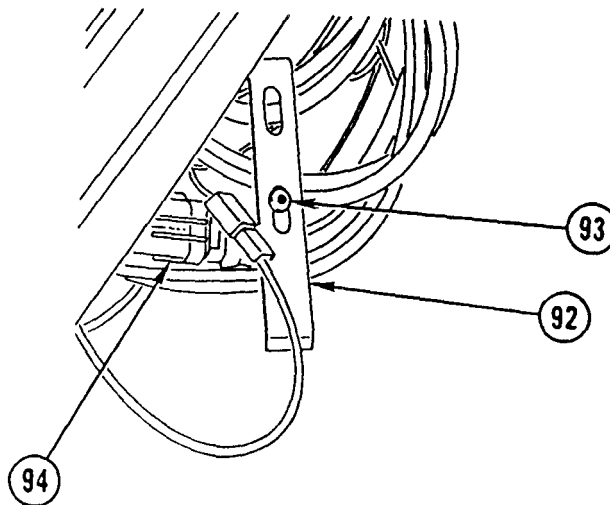

42. INSTALL RETAINER (92) AND TORX SCREW (93).
43. CONNECT ACCELERATOR CONNECTOR (94).

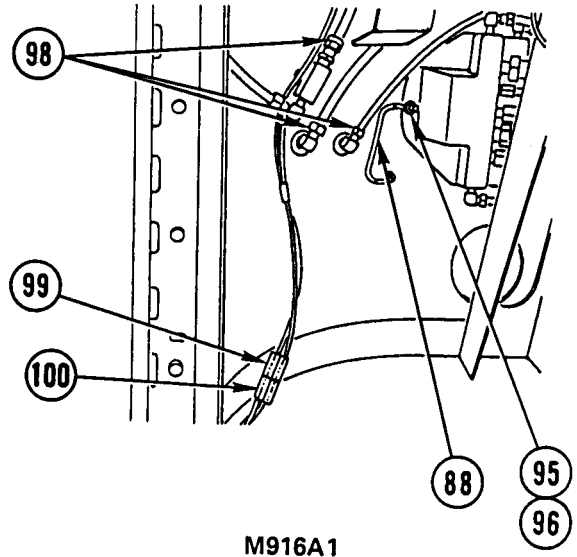
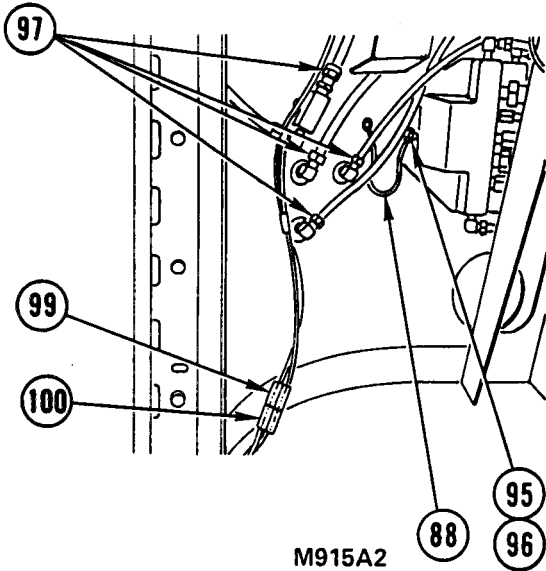

44. CONNECT GROUND CABLE (88) AND INSTALL WASHER (95) AND NEW LOCK NUT (96).

NOTE

Perform step 45 on M915A2 only.

45. CONNECT FOUR AIR LINES (97).

NOTE

Perform step 46 on M916A1 only.

46. CONNECT THREE AIR LINES (98).

47. CONNECT CONNECTOR (99) TO SIDE MARKER LIGHT CONNECTOR (100).

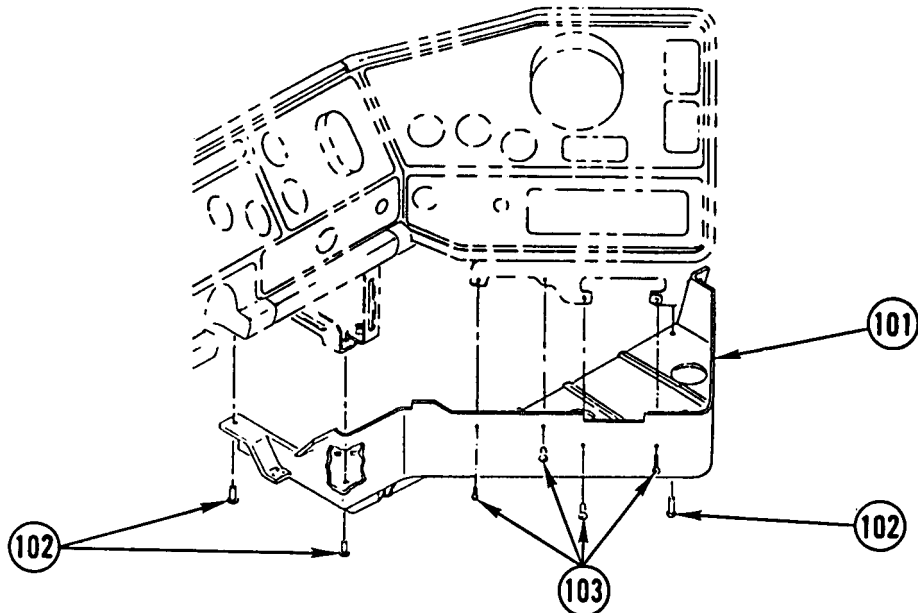

48. INSTALL LOWER PANEL (101), THREE TORX SCREWS (102), AND FOUR SCREWS (103).

DASHBOARD REPLACEMENT (CONT)

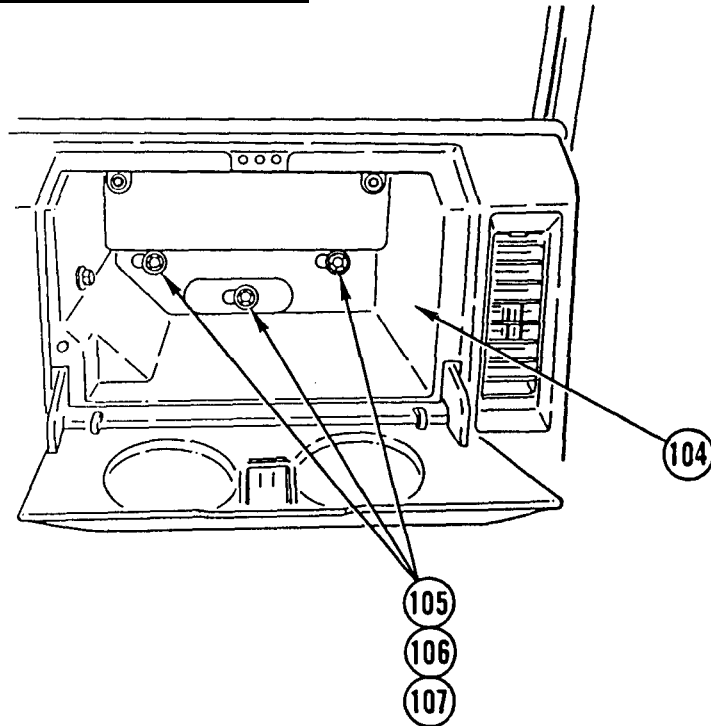

49. INSTALL COMPARTMENT (104), THREE INSERTS (105), THREE WASHERS (106), AND THREE NEW LOCK NUTS (107).

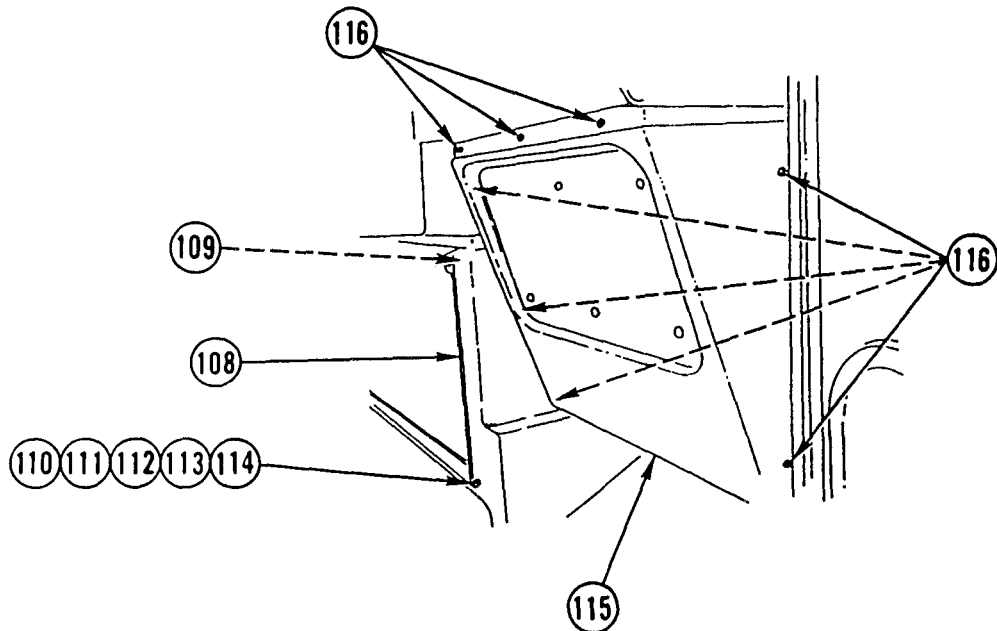

50. INSTALL COVER (108) AND SCREW (109).

51. INSTALL SPACER (110), WASHER (111), SCREW (112), WASHER (113), AND NEW LOCK NUT (114).

52. INSTALL COVER (115) AND NINE SELF-TAPPING SCREWS (116).

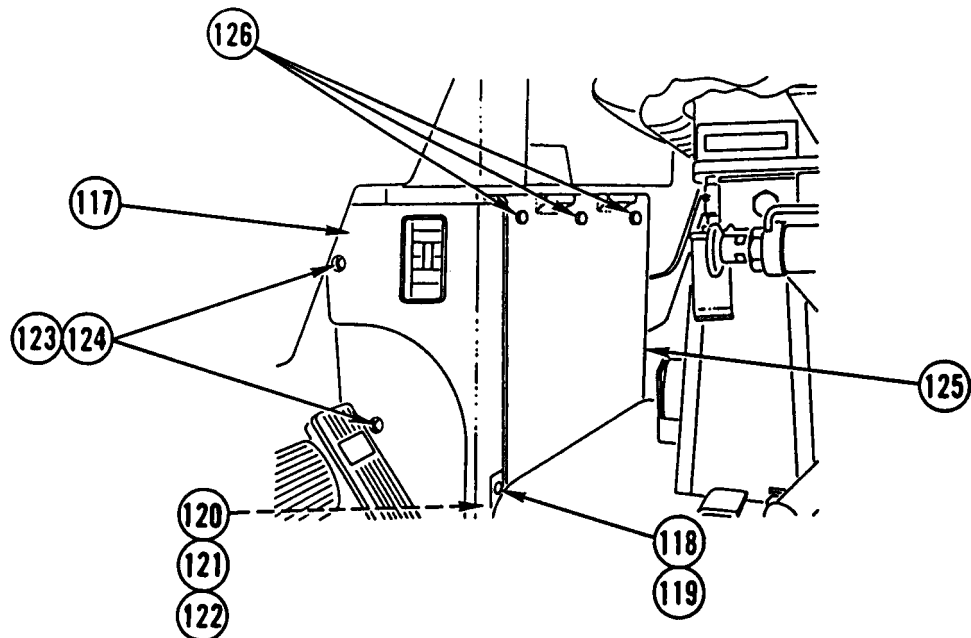

53. INSTALL COVER (117), WASHER (118), SCREW (119), SPACER (120), WASHER (121), AND NEW LOCK NUT (122).
54. INSTALL TWO WASHERS (1 23) AND TWO SCREWS (1 24).
55. INSTALL COVER (125) AND ROTATE THREE FASTENERS (126) TO RIGHT.

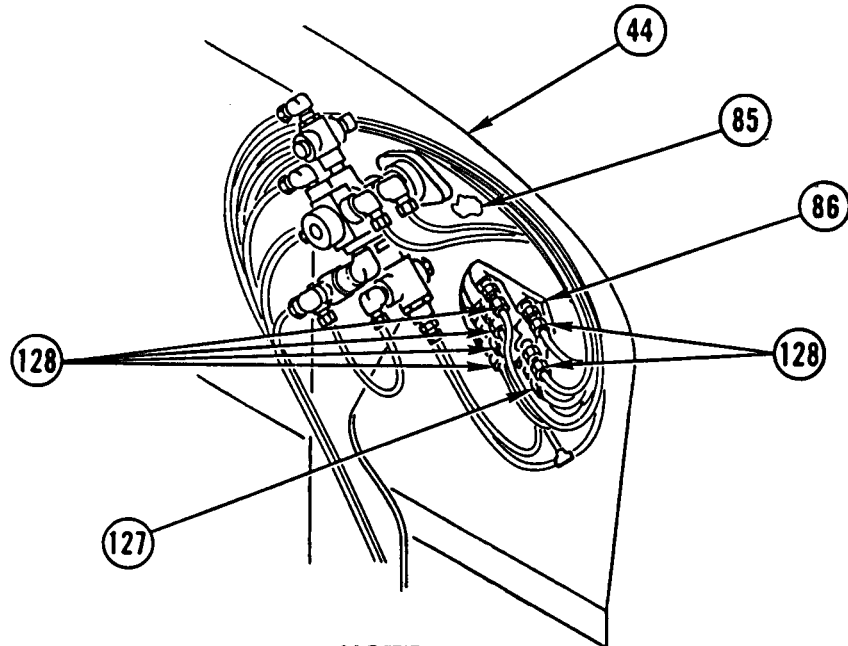

NOTE

Make sure all old sealing compound has been removed from fire wall before applying new sealing compound.

56. APPLY NEW SEALING COMPOUND (85) ON FIR EWALL (44).
57. CONNECT OIL LINE (127) AND SIX AIR LINES (128) TO JUNCTION BLOCK (86).

DASHBOARD REPLACEMENT (CONT)

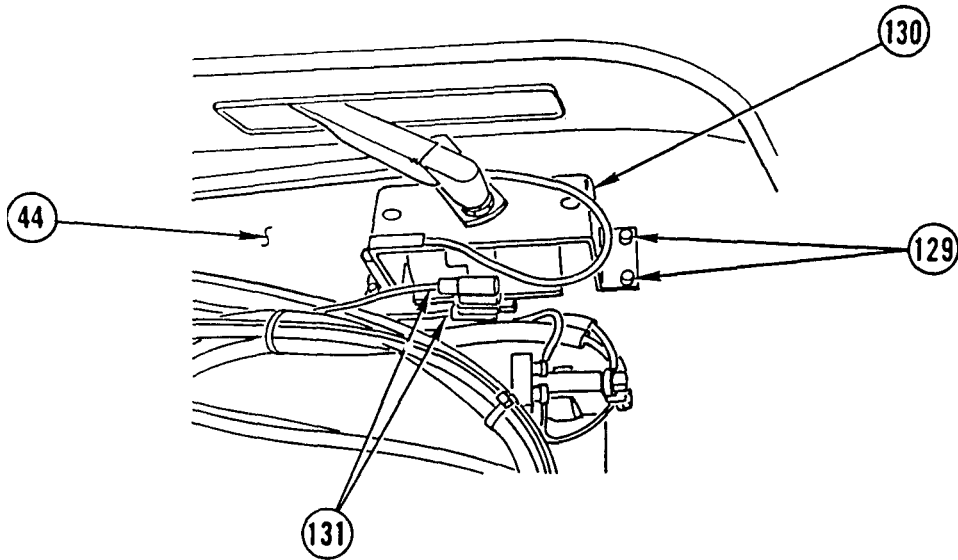

58. REMOVE FOUR SCREWS (129) AND PULL WINDSHIELD WIPER MOTOR (130) FAR ENOUGH AWAY FROM FIREWALL (44) TO CONNECT TWO AIR LINES (131).

59. INSTALL WINDSHIELD WIPER MOTOR (130) AND FOUR SCREWS (129).

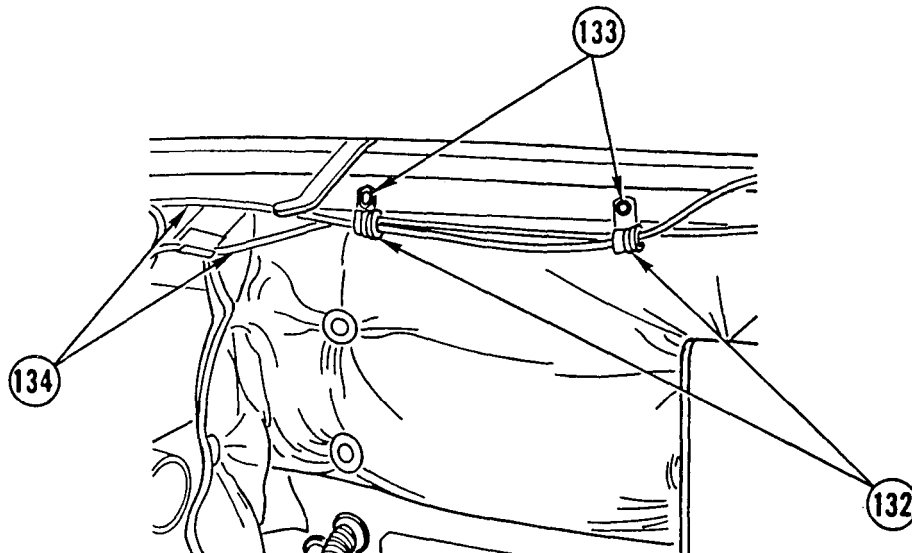

60. INSTALL TWO CLAMPS (132) AND TWO SCREWS (133) ON TWO AIR LINES (134).

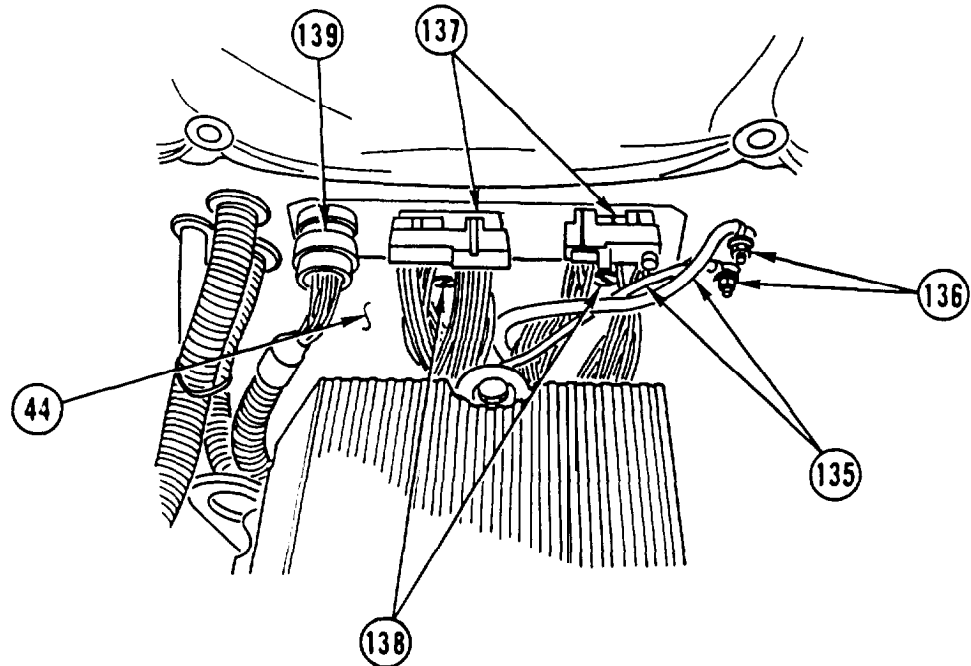

61. CONNECT TWO CABLES (135) AND INSTALL TWO NUTS (136).
62. CONNECT TWO CONNECTORS (137) AND TIGHTEN TWO SCREWS (138) TO FIREWALL (44).
63. CONNECT CONNECTOR (139) TO FIREWALL (44).

NOTE

Follow-on Maintenance:

- Install speedometer drive shaft and cable (TM 9-2320-363-20).
- Install tachometer cable (TM 9-2320-363-20).
- Install steering wheel and column (TM 9-2320-363-20).
- Connect batteries (TM 9-2320-363-20).
- Install air cleaner, pre-cleaner, and duct assembly (TM 9-2320-363-20).

AIR DUCTS REPLACEMENT

This task covers: a. Removal b. Cleaning c. Inspection d. Installation

INITIAL SETUP

Applicable Configuration:

M915A2 and M916A1

Tools and Special Equipment:

Tool Kit, SC 5180-90-CL-N05

Equipment Condition:

Reference

Page 10-3

Condition Description

Dashboard Removed

REMOVAL

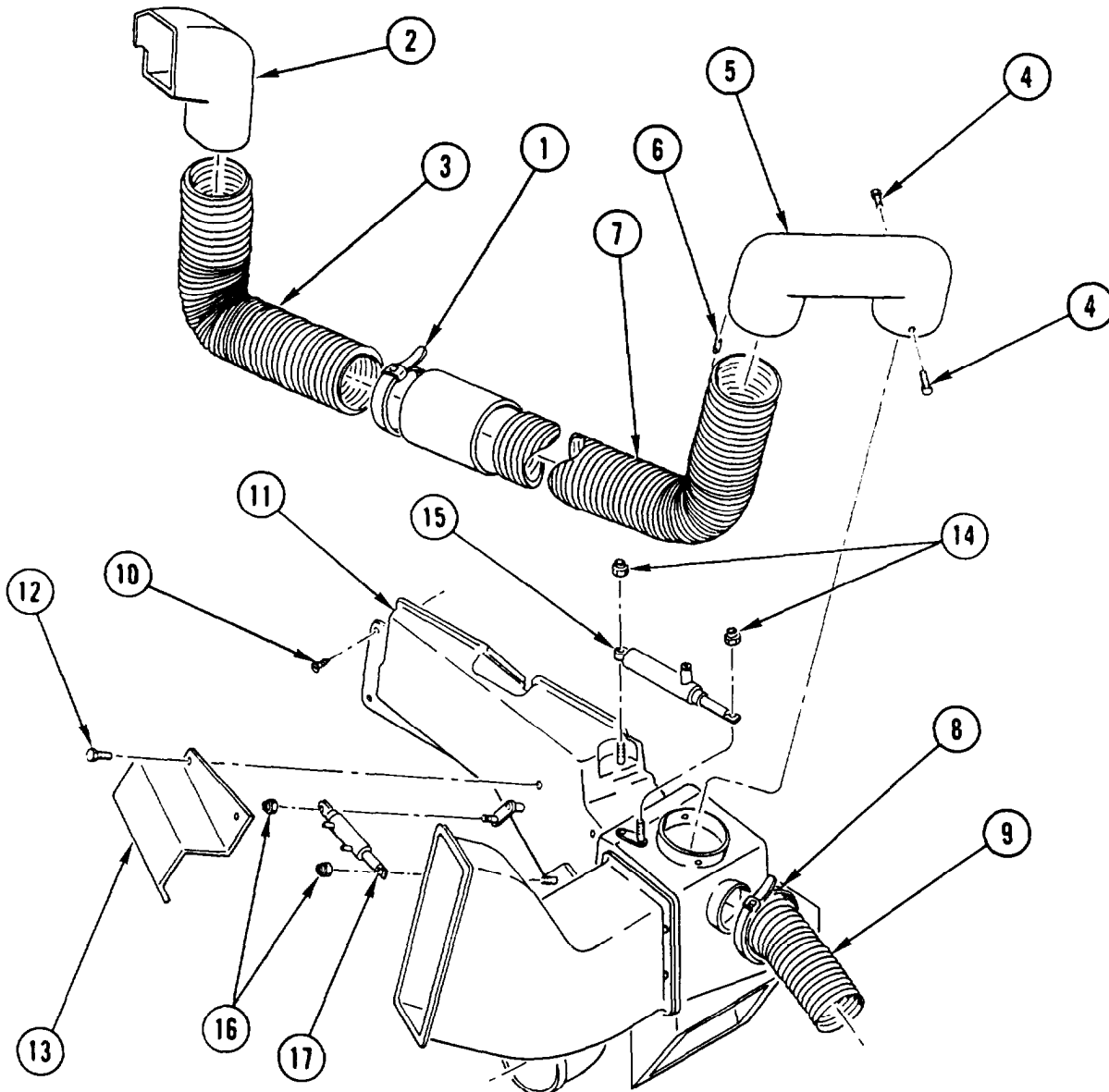

1. REMOVE TIE WRAP (1), DUCT (2), AND FLEX HOSE (3).
2. REMOVE TWO SELF-TAPPING SCREWS (4) AND DUCT (5).
3. REMOVE FIVE CLIPS (6) AND FLEX HOSE (7) FROM DUCT (5).
4. REMOVE TIE WRAP (8) AND FLEX HOSE (9).
5. REMOVE THREE SELF-TAPPING SCREWS (10) AND MAIN DUCT ASSEMBLY (11).
6. REMOVE TWO SCREWS (12) AND COVER (13).
7. REMOVE TWO RETAINERS (14) AND AIR CYLINDER (15).
8. REMOVE TWO RETAINERS (16) AND AIR CYLINDER (17).

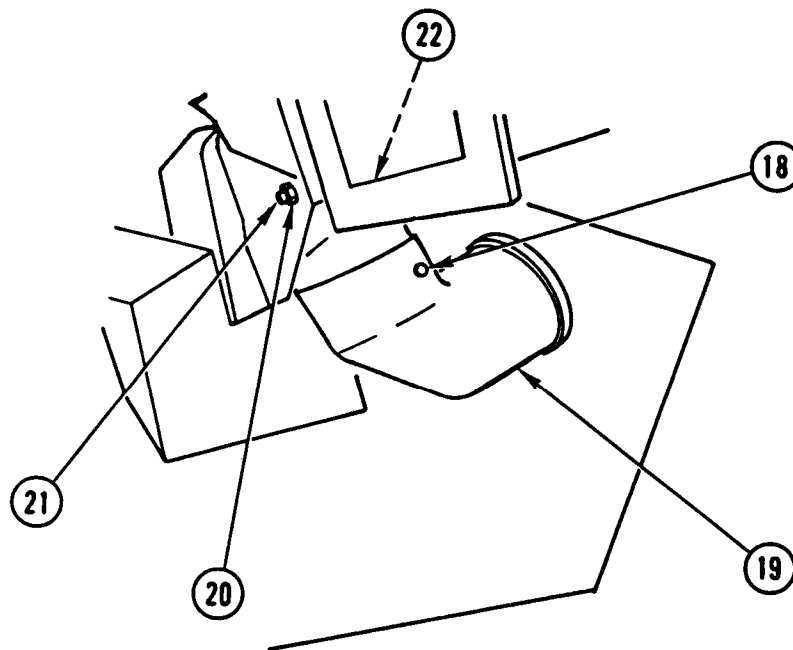

9. REMOVE TWO SCREWS (18) AND DUCT (19).
10. REMOVE RETAINER (20), SHAFT (21), AND DOOR (22).

CLEANING

Use general cleaning methods to clean all parts (page 2-30).

INSPECTION

Inspect all parts for wear or damage.

AIR DUCTS REPLACEMENT (CONT)

INSTALLATION

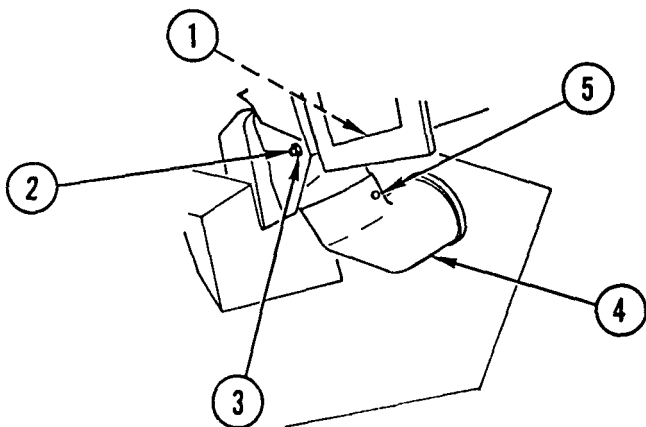

1. INSTALL DOOR (1), SHAFT (2), AND RETAINER (3).
2. INSTALL DUCT (4) AND TWO SCREWS (5).

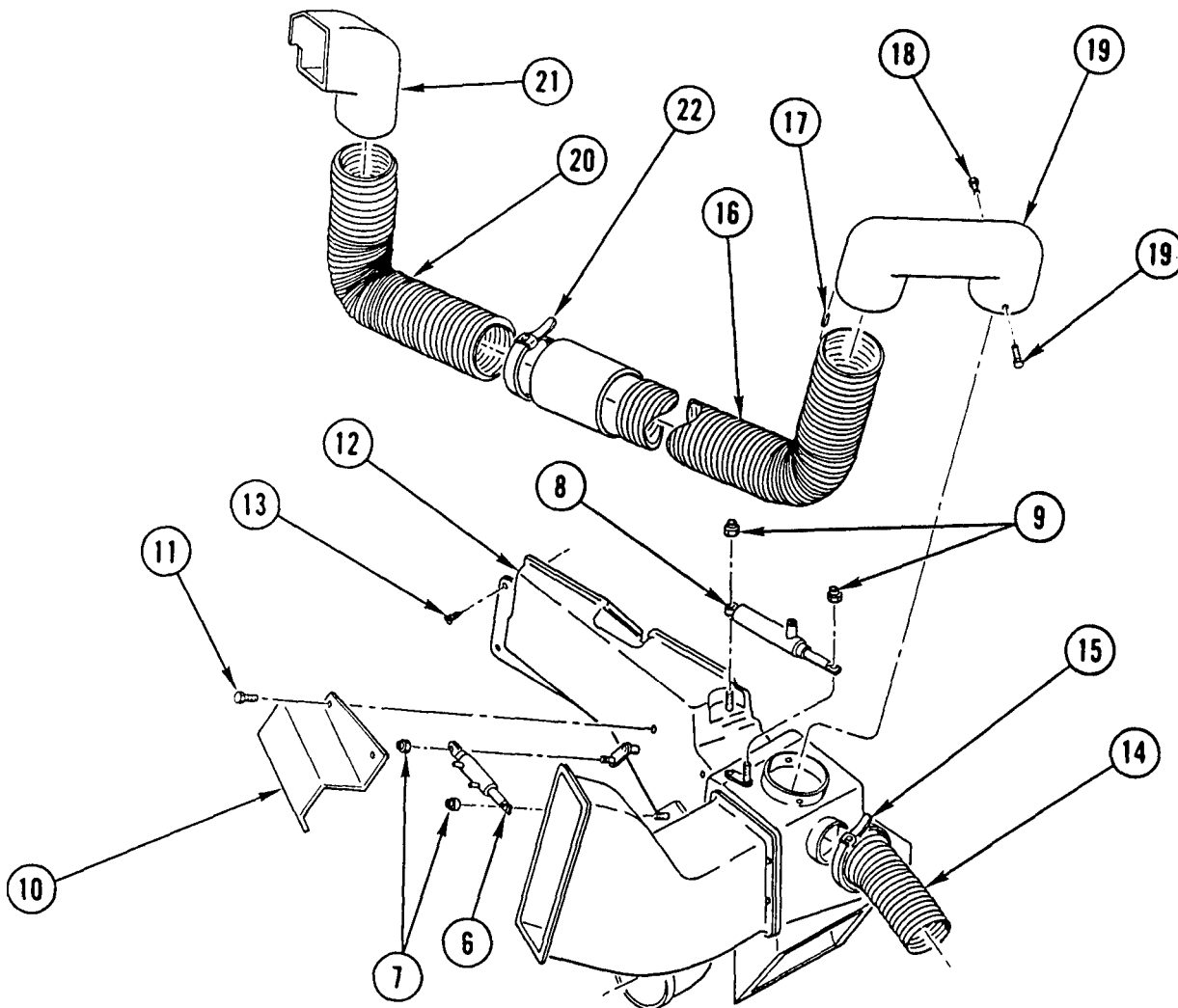

3. INSTALL AIR CYLINDER (6) AND TWO RETAINERS (7).
4. INSTALL AIR CYLINDER (8) AND TWO RETAINERS (9).
5. INSTALL COVER (10) AND TWO SCREWS (11).
6. INSTALL MAIN DUCT ASSEMBLY (12) AND THREE SELF-TAPPING SCREWS (13).
7. INSTALL FLEX HOSE (14) AND TIE WRAP (15).
8. INSTALL FLEX HOSE (16) AND FIVE CLIPS (17) ON DUCT (18).
9. INSTALL DUCT (18) AND TWO SELF-TAPPING SCREWS (19).
10. INSTALL FLEX HOSE (20), DUCT (21), AND TIE WRAP (22).

NOTE

Follow-on Maintenance:
Install dashboard (page 10-3).

AIR DUCTS REPLACEMENT

This task covers: a. Removal b. Cleaning c. Inspection d. Installation

INITIAL SETUP

Applicable Configuration:

All except M915A2 and M916A1

Tools and Special Equipment:

Tool Kit. SC 5180-90-CL-N26

Equipment Condition:

Reference

Page 10-3

Condition Description

Dashboard Removed

REMOVAL

1. REMOVE EIGHT RETAINERS (1) AND FOUR AIR CYLINDERS (2).
2. REMOVE TWO SELF-TAPPING SCREWS (3) AND SEPARATE FLEX TUBING (4) FROM DUCT (5).
3. REMOVE TWO SCREWS (6), DUCT OUTLET (7), AND DUCT (5).
4. REMOVE TWO SELF-TAPPING SCREWS (8), DUCT (9), AND FLEX TUBING (4).
5. REMOVE FIVE CLIPS (10) AND SEPARATE FLEX TUBING (4) FROM DUCT (9).
6. REMOVE HOSE CLAMP (11), FLEX TUBING (12), AND DUCT OUTLET (13).
7. REMOVE TWO SELF-TAPPING SCREWS (14) AND SEPARATE FLEX TUBING (12) FROM DUCT OUTLET (13).
8. REMOVE SELF-TAPPING SCREW (15), SPEED NUT (16), AND OUTLET DUCT (17) FROM DUCT (18).
9. REMOVE SELF-TAPPING SCREW (19), WASHER (20), SPRING NUT (21), AND DUCT (18).
10. REMOVE SCREW (22), VENT (23), AND GASKET (24).
11. REMOVE THREE SELF-TAPPING SCREWS (25) AND FACE DUCT (26).

CLEANING

Use general cleaning methods to clean all parts (page 2-30).

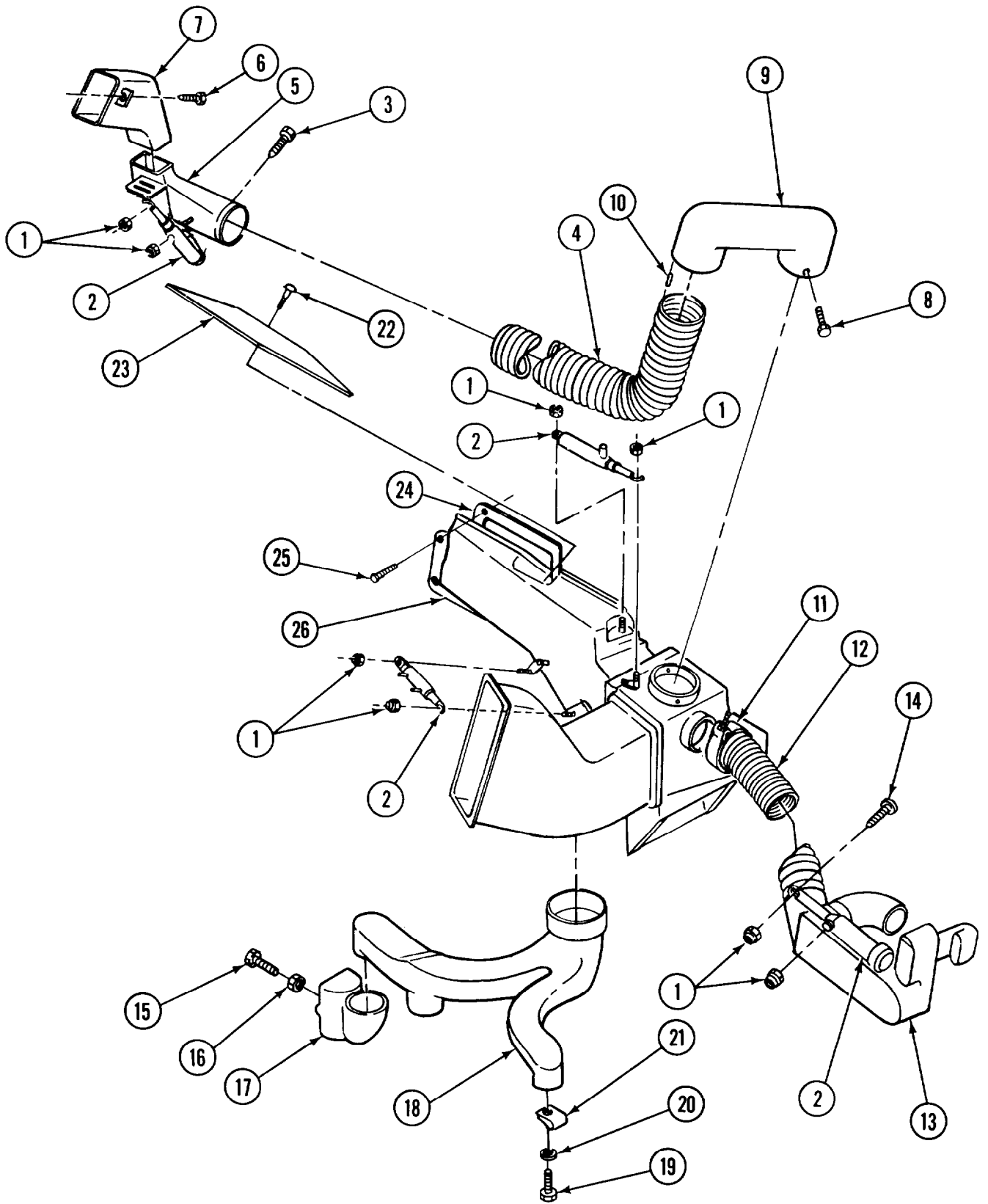

AIR DUCTS REPLACEMENT (CONT)

INSPECTION

Inspect all parts for wear or damage.

INSTALLATION

1. INSTALL FACE DUCT (1) AND SECURE WITH THREE SELF-TAPPING SCREWS (2).
2. INSTALL GASKET (3), VENT (4), AND SECURE WITH SCREW (5).
3. INSTALL DUCT (6) AND SECURE WITH SPRING NUT (7), WASHER (8), AND SELF-TAPPING SCREW (9).
4. INSTALL OUTLET DUCT (10) AND SECURE WITH SPEED NUT (11) AND SELF-TAPPING SCREW (12).
5. CONNECT FLEX TUBING (13) TO DUCT OUTLET (14) AND SECURE WITH TWO SELF-TAPPING SCREWS (15).
6. CONNECT FLEX TUBING (13) TO FACE DUCT (1) AND SECURE WITH HOSE CLAMP (16).
7. CONNECT FLEX TUBING (17) TO DUCT (18) AND SECURE WITH FIVE CLIPS (19).
8. CONNECT DUCT (18) TO FACE DUCT (1) AND SECURE WITH TWO SELF-TAPPING SCREWS (20).
9. CONNECT FLEX TUBING (17) TO DUCT (21) AND SECURE WITH TWO SELF-TAPPING SCREWS (22).
10. INSTALL DUCT (21) TO DUCT OUTLET (23) AND SECURE WITH TWO SCREWS (24).
11. INSTALL FOUR AIR CYLINDERS (25) AND SECURE WITH EIGHT RETAINERS (26).

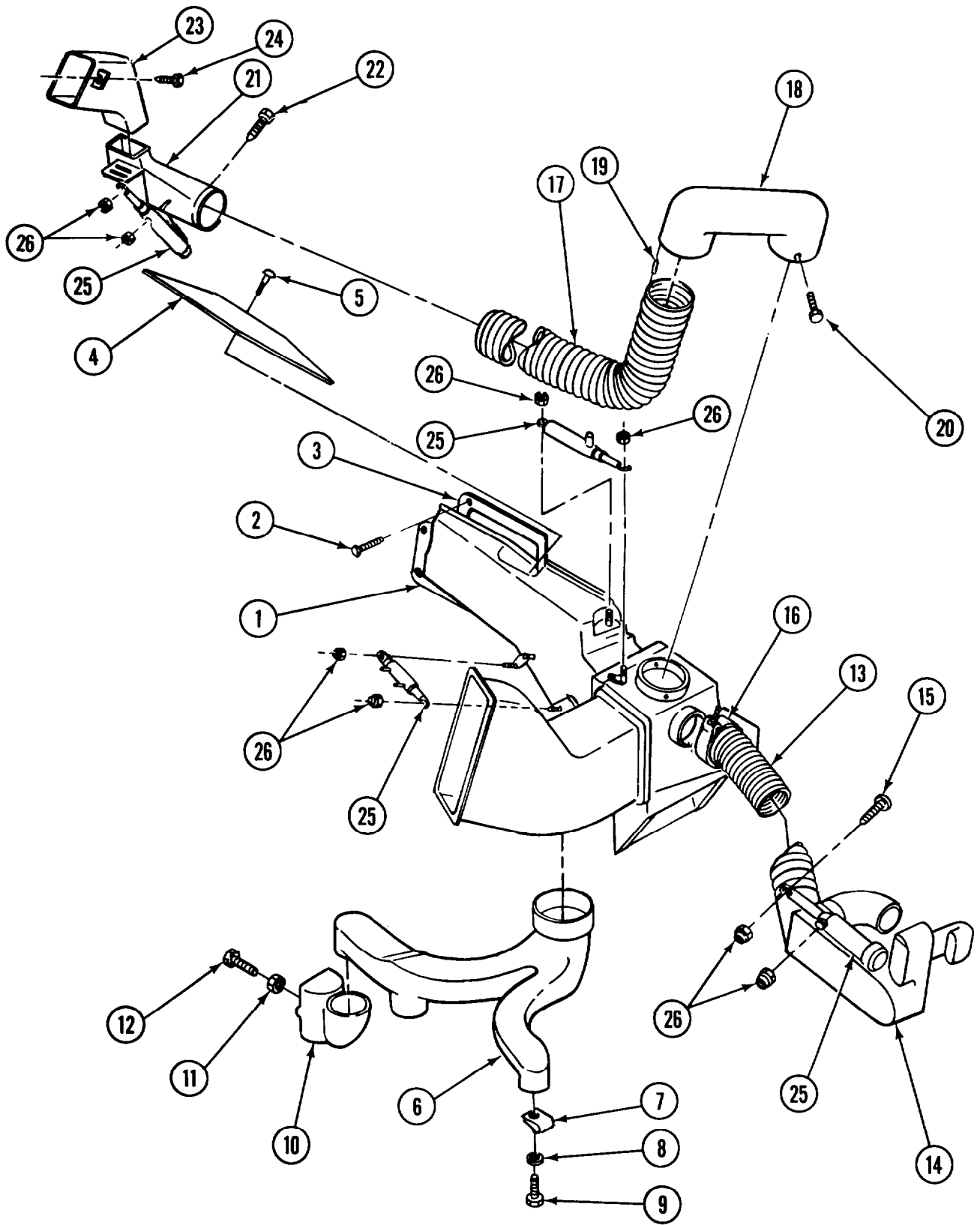

NOTE
Follow-on Maintenance:

Install dashboard (page 10-3).

FRONT CAB MOUNTS REPLACEMENT

This task covers: a. Removal b. Cleaning c. Inspection d. Installation

INITIAL SETUP

Tools and Special Equipment:

Shop Equipment, SC 4910-95-CL-A31
Tool Kit, SC 5180-90-CL-N05
Cab Sling, J39520

Equipment Condition:

Reference	Condition Description
TM 9-2320-363-20	Fender Extension Removed

Materials/Parts:

Clamp, Seal P/N KYX00-5833

Nut, Lock

Personnel Required: (2)

References:

TM 9-2320-363-20

General Safety Instructions:

WARNING
Cab assembly weighs 1,100 lb (499 kg). Use hoist with lifting capacity of 1,400 lb (636 kg) to support cab assembly. Failure to do so could result in injury to personnel and/or damage to cab assembly.

REMOVAL

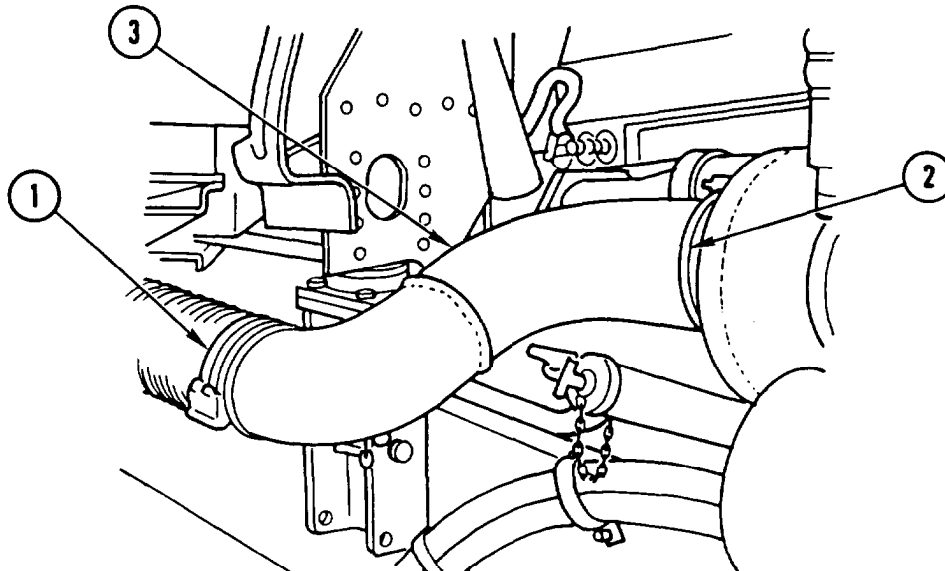

NOTE

- Procedure is the same for both vehicles except as noted.
- Procedure is the same for both sides except as noted.
- Perform step 1 on right side.

1. REMOVE SEAL CLAMP (1), V CLAMP (2), AND OUTLET PIPE (3). DISCARD SEAL CLAMP.

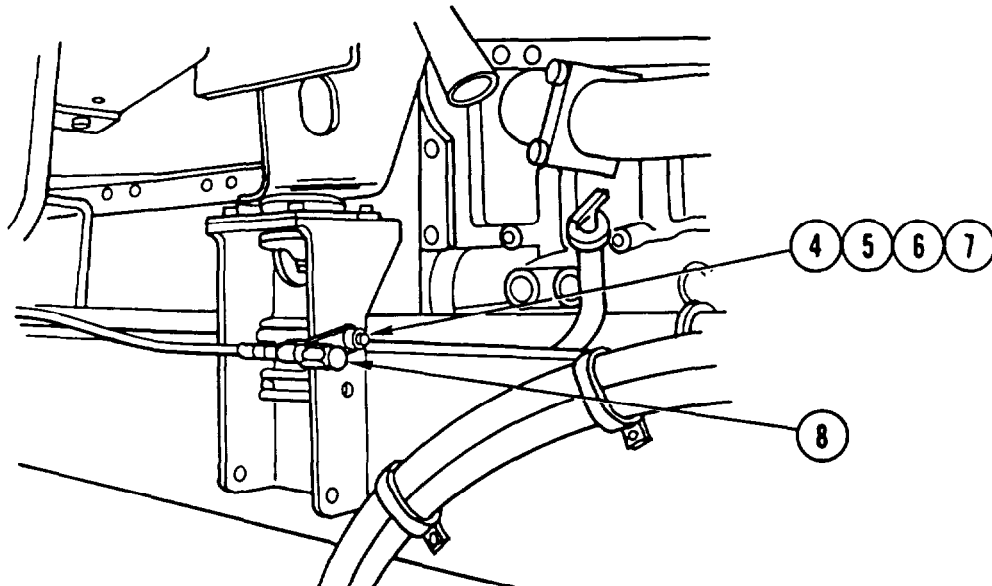

2. REMOVE NUT (4), WASHER (5), BOLT (6), AND WASHER (7).

NOTE

Perform step 3 on right side.

3. REMOVE AOAP SAMPLE VALVE (8) AND SET ASIDE.

FRONT CAB MOUNTS REPLACEMENT (CONT)

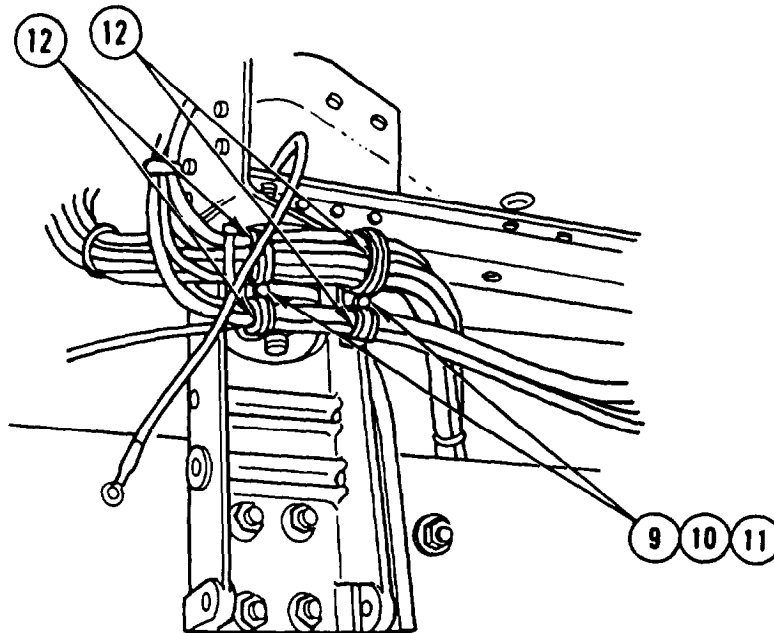

NOTE

Perform step 4 on left side of M915A2.

4. REMOVE TWO NUTS (9), TWO WASHERS (10), TWO SCREWS (11), AND FOUR CLAMPS (12).

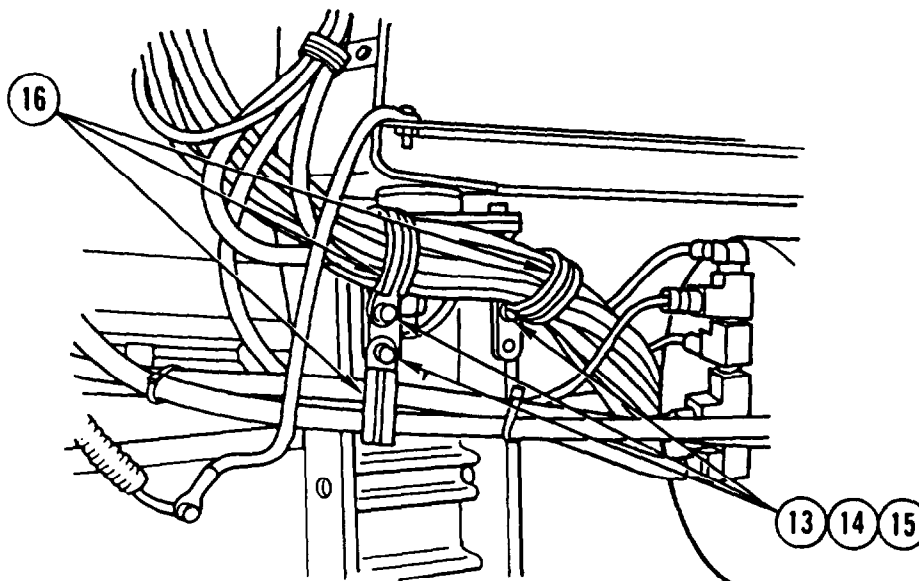

NOTE

Perform step 5 on left side of all except M915A2.

5. REMOVE THREE NUTS (13), THREE WASHERS (14), THREE SCREWS (15), AND THREE CLAMPS (16).

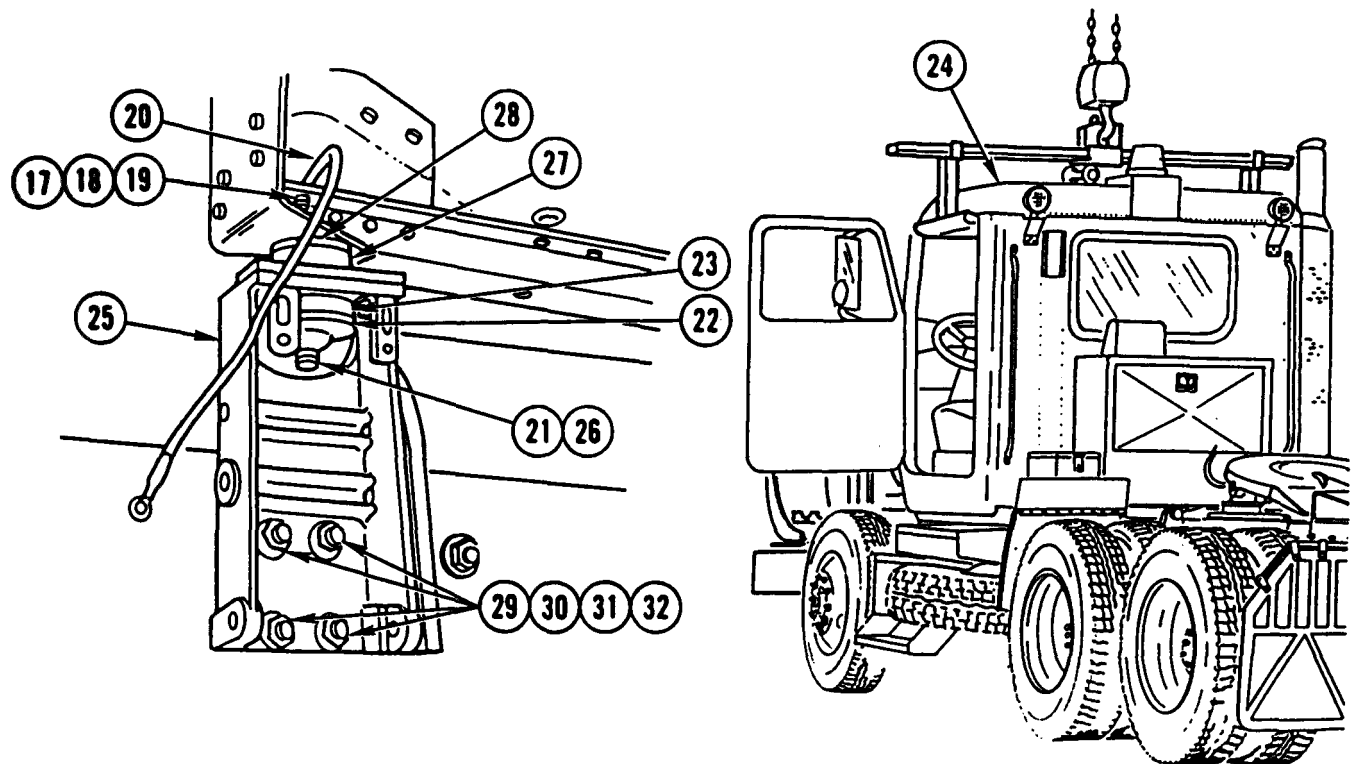

NOTE

Perform step 6 on left side.

6. REMOVE LOCK NUT (17), WASHER (18), AND SCREW (19), DISCONNECT CABLE (20) AND SET ASIDE. DISCARD LOCK NUT.
7. REMOVE NUT (21), WASHER (22), AND BUSHING (23).

WARNING

Cab assembly weighs 1,100 lb (499 kg). Use hoist with lifting capacity of 1,400 lb (636 kg) to support cab assembly. Failure to do so could result in injury to personnel and/or damage to cab assembly.

8. USING CAB SLING AND HOIST, LIFT CAB ASSEMBLY (24) JUST ENOUGH TO REMOVE ALL SLACK AND NOT ALLOW CAB ASSEMBLY (24) TO DROP WHEN FRONT CAB MOUNTS (25) ARE REMOVED.
9. REMOVE SCREW (26), BUSHING (27), AND WASHER (28).
10. REMOVE FOUR NUTS (29), FOUR WASHERS (30), FOUR SCREWS (31), FOUR WASHERS (32), AND FRONT CAB MOUNT (25).

FRONT CAB MOUNTS REPLACEMENT (CONT)

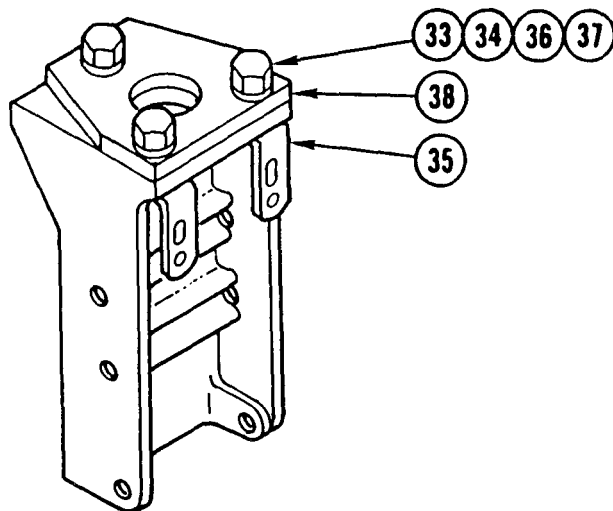

NOTE

Perform step 11 on left side.

11. REMOVE THREE NUTS (33), THREE WASHERS (34), TWO BRACKETS (35), THREE SCREWS (36), THREE WASHERS (37), AND PLATE (38).

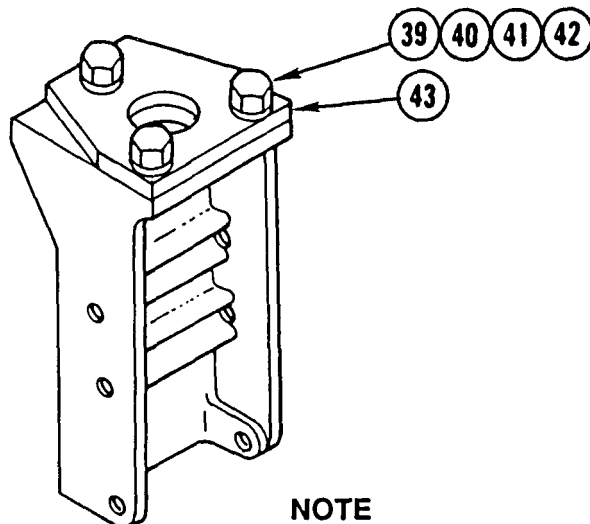

NOTE

Perform step 12 on right side.

12. REMOVE THREE NUTS (39), THREE WASHERS (40), THREE SCREWS (41), THREE WASHERS (42), AND PLATE (43).

CLEANING

Use general cleaning methods to clean all parts (page 2-30).

INSPECTION

Inspect all parts for wear or damage.

INSTALLATION

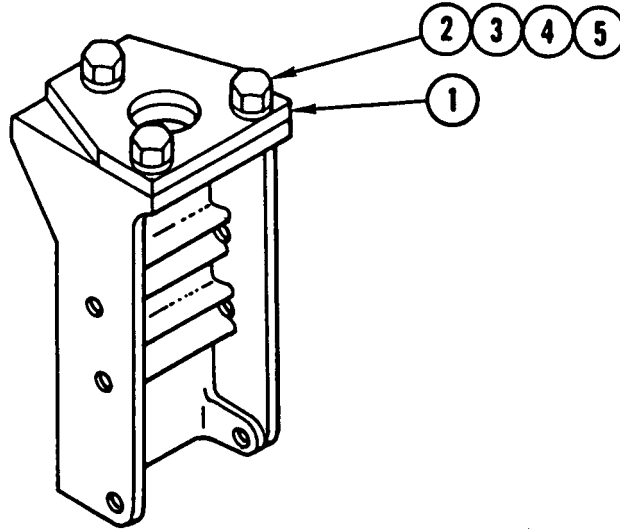

WARNING

Cab assembly weighs 1,100 lb (499 kg). Use hoist with lifting capacity of 1,400 lb (636 kg) to support cab assembly. Failure to do so could result in injury to personnel and/or damage to cab assembly.

NOTE

- Procedure is the same for both vehicles except as noted.
- Procedure is the same for both sides except as noted.
- Perform step 1 on right side.

1. INSTALL PLATE (1), THREE WASHERS (2), THREE SCREWS (3), THREE WASHERS (4), AND THREE NUTS (5).

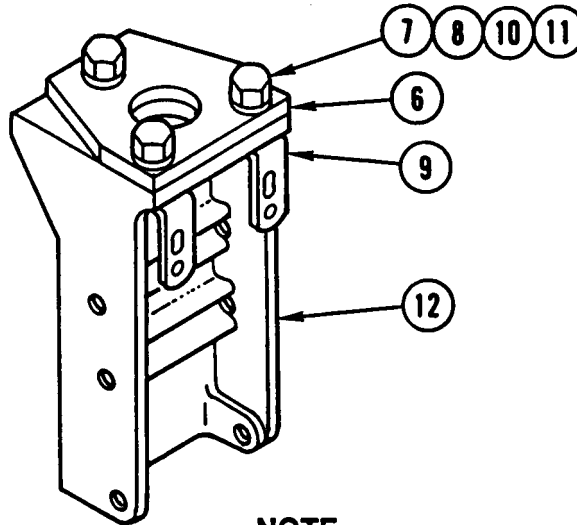

NOTE

Perform step 2 on left side.

2. INSTALL PLATE (6), THREE WASHERS (7), THREE SCREWS (8), TWO BRACKETS (9), THREE WASHERS (10), AND THREE NUTS (11).

FRONT CAB MOUNTS REPLACEMENT (CONT)

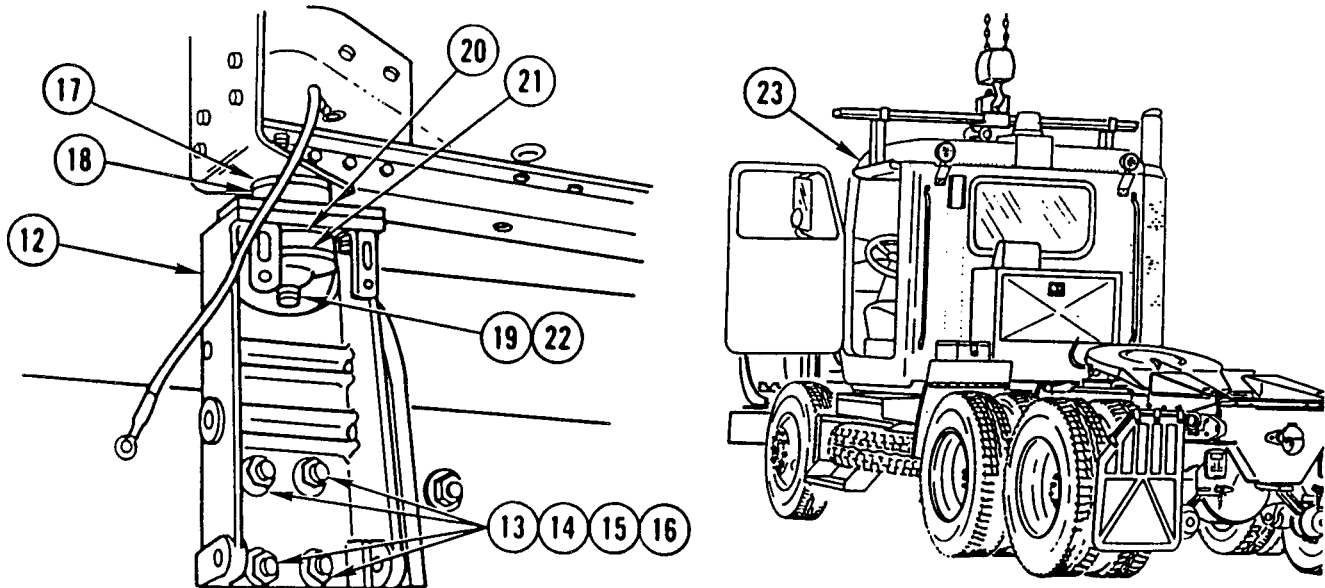

3. INSTALL FRONT CAB MOUNT (12), FOUR WASHERS (13), FOUR SCREWS (14), FOUR WASHERS (15), AND FOUR NUTS (16).
4. INSTALL WASHER (17), BUSHING (18), AND SCREW (19).
5. INSTALL BUSHING (20), WASHER (21), AND NUT (22).
6. REMOVE CAB SLING AND HOIST FROM CAB ASSEMBLY.

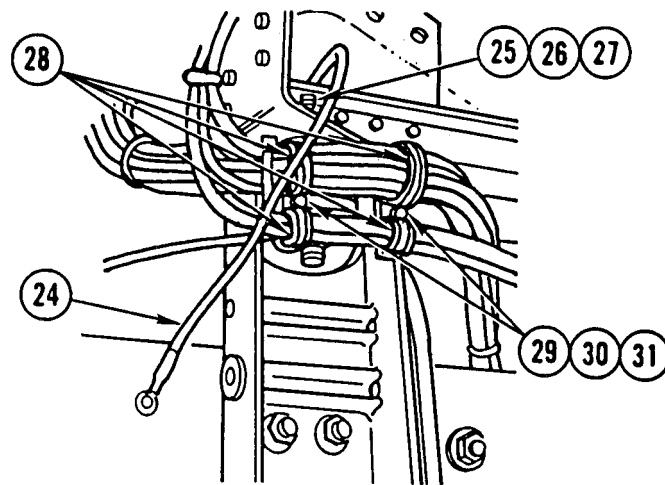

NOTE

Perform step 7 on left side.

7. CONNECT CABLE (24) AND INSTALL SCREW (25), WASHER (26), AND NEW LOCK NUT (27).

NOTE

Perform step 8 on left side of M915A2.

8. INSTALL FOUR CLAMPS (28), TWO SCREWS (29), TWO WASHERS (30), AND TWO NUTS (31).

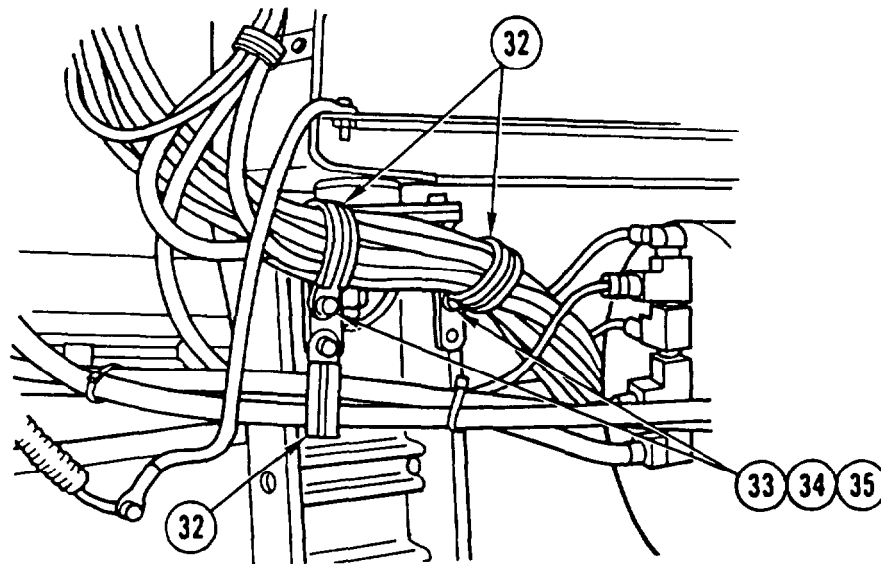

NOTE

Perform step 9 on left side of all except M915A2

9. INSTALL THREE CLAMPS (32), THREE SCREWS (33), THREE WASHERS (34), AND THREE NUTS (35).

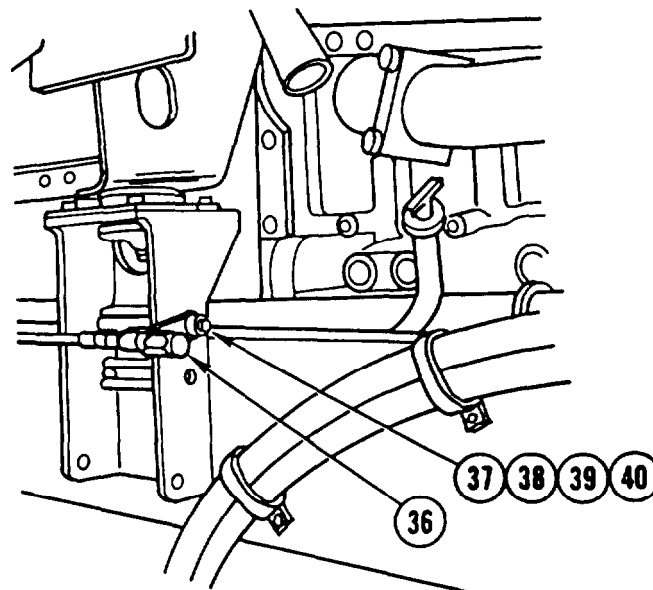

NOTE

Perform step 10 on right side.

10. INSTALL AOAP SAMPLE VALVE (36).
11. INSTALL WASHER (37), BOLT (38), WASHER (39), AND NUT (40).

FRONT CAB MOUNTS REPLACEMENT (CONT)

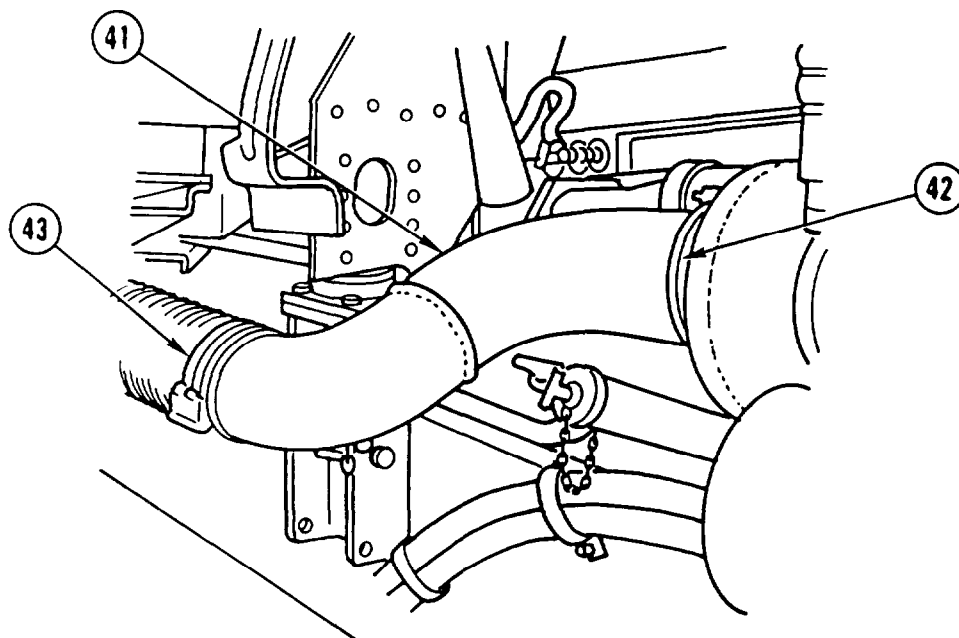

NOTE

Perform step 12 on right side.

12. INSTALL OUTLET PIPE (41), V CLAMP (42), AND NEW SEAL CLAMP (43).

NOTE

Follow-on maintenance:
Install fender extension (TM 9-2320-363-20).

REAR CAB MOUNTS REPLACEMENT

This task covers: a. Removal b. Cleaning c. Inspection d. Installation

INITIAL SETUP

Tools and Special Equipment:

Tool Kit, SC 5180-90-CL-N05

Materials/Parts:

Nut, Lock (8)

Personnel Required: (2)

Equipment Condition:

Reference

Page 10-40

Condition Description

Front Cab Mounts
Removed

REMOVAL

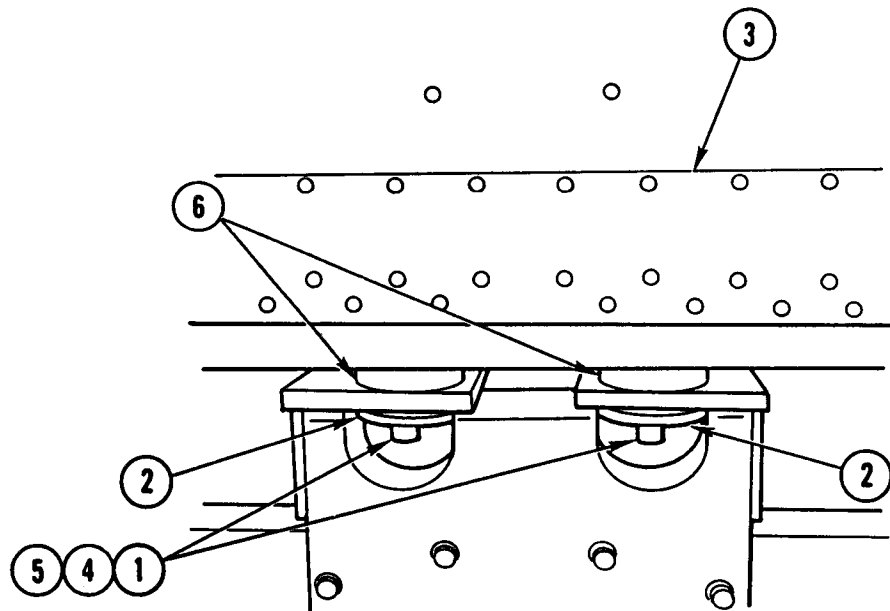

1. REMOVE TWO NUTS (1) AND TWO WASHERS (2).
2. LIFT CAB ASSEMBLY (3) APPROXIMATELY 5 IN. (127 mm).
3. REMOVE TWO BOLTS (4), TWO WASHERS (5), AND TWO BUSHINGS (6).

REAR CAB MOUNTS REPLACEMENT (CONT)

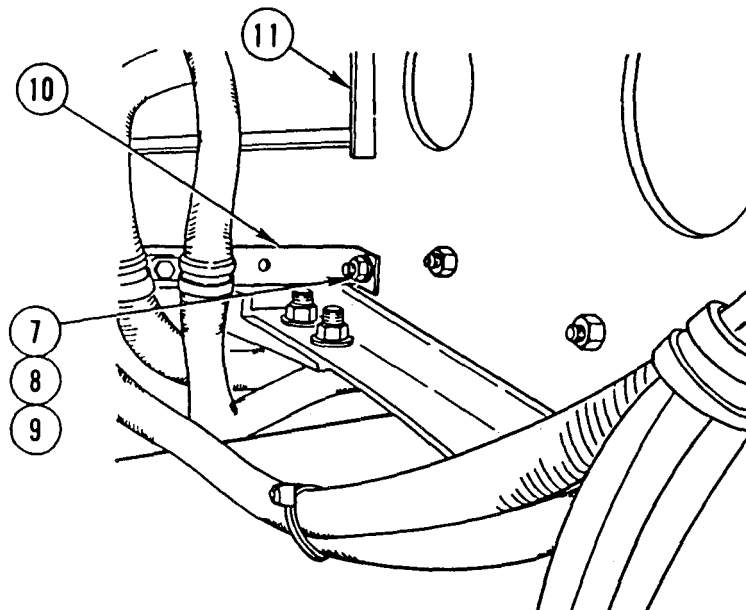

4. REMOVE EIGHT LOCK NUTS (7), EIGHT SCREWS (8), EIGHT WASHERS (9), AND BRACKET (10) DISCARD LOCK NUTS.
5. REMOVE BRACKET (11).

CLEANING

Use general cleaning methods to clean all parts (page 2-30).

INSPECTION

Inspect all parts for wear or damage.

INSTALLATION

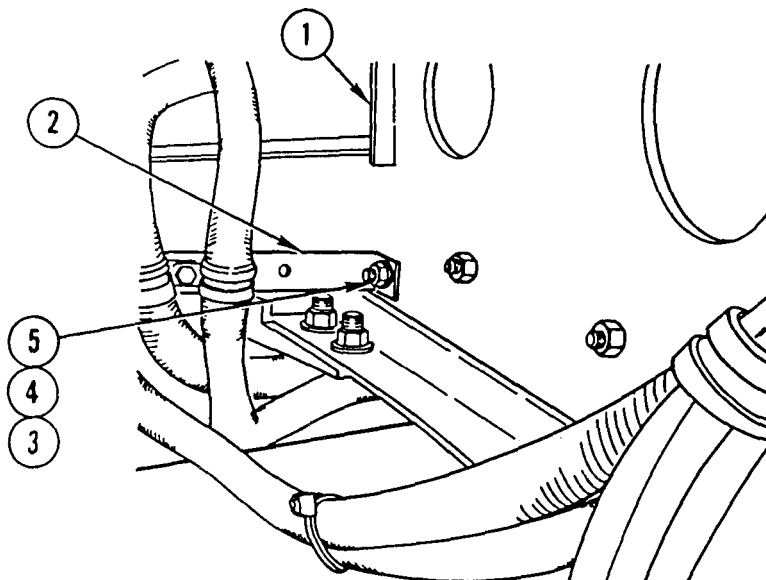

1. INSTALL BRACKET (1).
2. INSTALL BRACKET (2), EIGHT WASHERS (3), EIGHT SCREWS (4), AND EIGHT NEW LOCK NUTS (5).

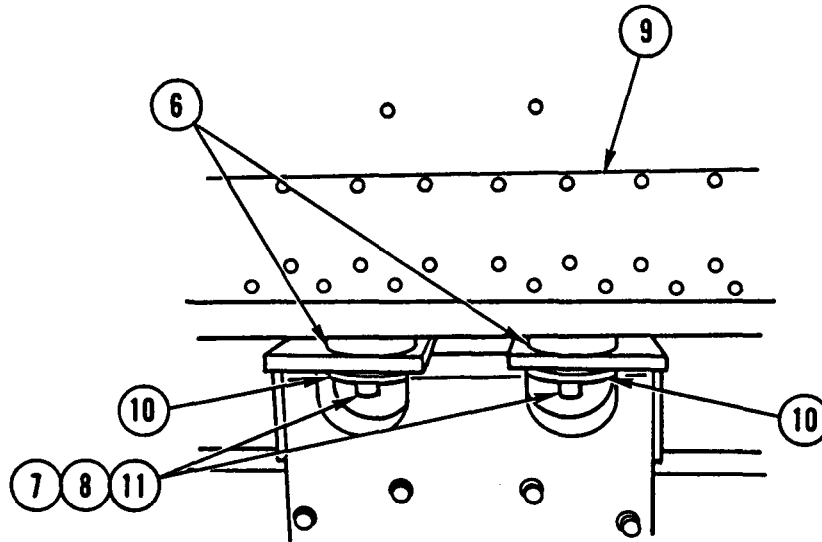

3. INSTALL TWO BUSHINGS (6), TWO WASHERS (7), AND TWO BOLTS (8).
4. LOWER CAB ASSEMBLY (9) AND MAINTAIN JUST ENOUGH SUPPORT TO KEEP SLACK OUT OF CHAIN.
5. INSTALL TWO WASHERS (10) AND TWO NUTS (11).

NOTE

Follow-on maintenance:
Install front cab mounts (page 10-40).

WINDSHIELD REPLACEMENT

This task covers: a. Removal b. Cleaning c. Inspection d. Installation

INITIAL SETUP

Tools and Special Equipment:

Tool Kit, SC 5180-90-CL-N05
Tool Kit, SC 4940-95-CL-A18

Materials/Parts:

Lockstrip P/N 18-23531-000

Personnel Required: (3)

References:

TM 9-2320-363-20

Equipment Condition:

Reference	Condition Description
TM 9-2320-363-20	Windshield Wiper and Wiper Arms Removed

General Safety Instructions:

WARNING

Wear protective gloves when handling glass. Failure to do so could result in injury to personnel.

REMOVAL

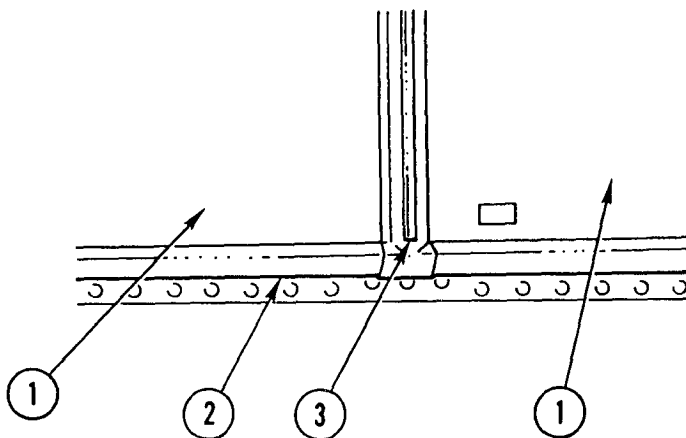

NOTE

Steps 1 thru 3 are the same for each windshield glass.

1. IF WINDSHIELD GLASS (1) IS CRACKED DUE TO ANY CAUSE OTHER THAN BEING HIT BY A FLYING OBJECT, MARK SEAL (2) AT LOCATION OF CRACK.
2. USING WINDSHIELD PICK, REMOVE AND DISCARD LOCKSTRIP (3).

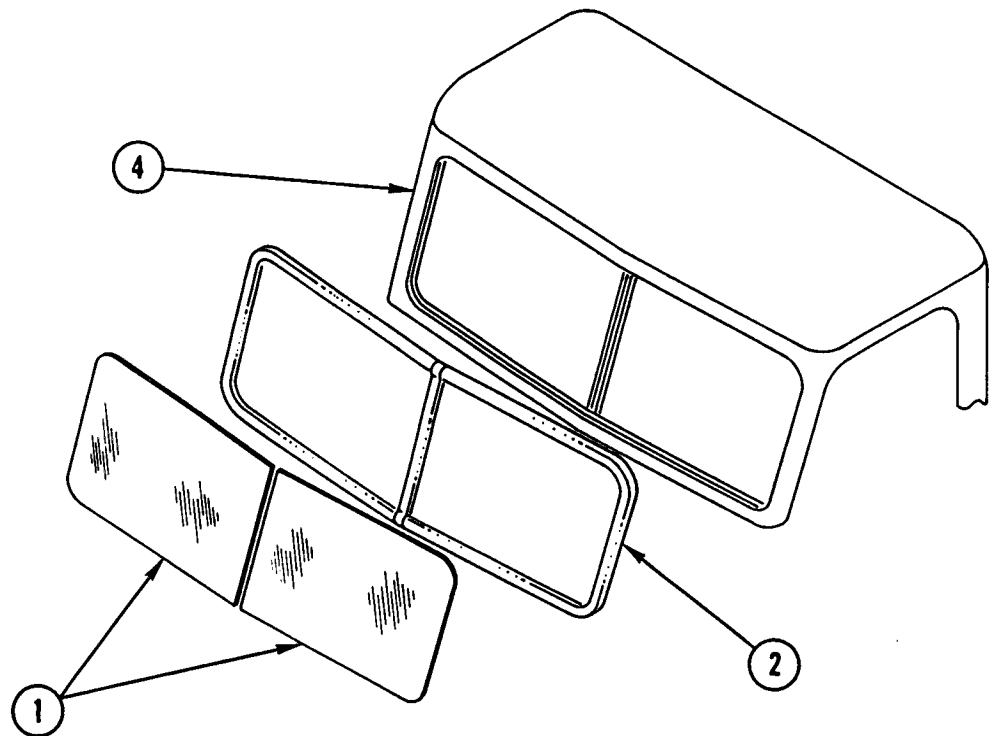

WARNING

Wear protective gloves when handling glass. Failure to do so could result in injury to personnel.

CAUTION

When handling windshield glass, be careful not to nick or splinter edges of glass. Chipped edges could cause cracking later.

NOTE

If removing windshield glass only, perform step 3. If removing seal or windshield glass and seal, perform steps 3 thru 11.

3. APPLY PRESSURE TO EDGE OF WINDSHIELD GLASS (1) FROM INSIDE CAB (4). USING WINDSHIELD PICK, LIFT WINDSHIELD GLASS(1) OUTOF SEAL (2) AND REMOVE.
4. REMOVE SEAL (2) FROM MOUNTING FLANGE OF CAB (4).

WINDSHIELD REPLACEMENT (CONT)

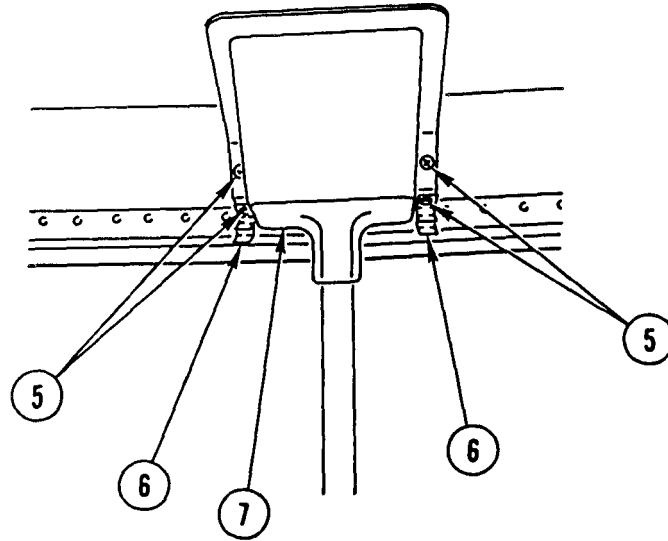

5. REMOVE FOUR TORX SCREWS (5), TWO BRACKETS (6), AND COVER (7).

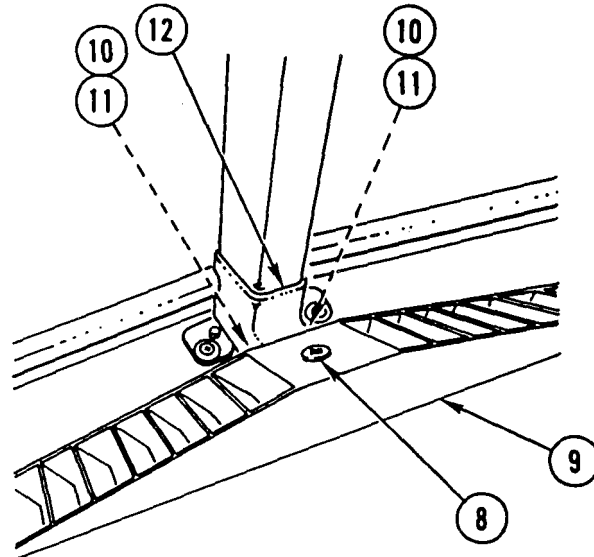

6. REMOVE TORX SCREW (8) AND DEFROSTER VENT (9).
7. REMOVE TWO TORX SCREWS (10), TWO WASHERS (11), AND COVER (12).

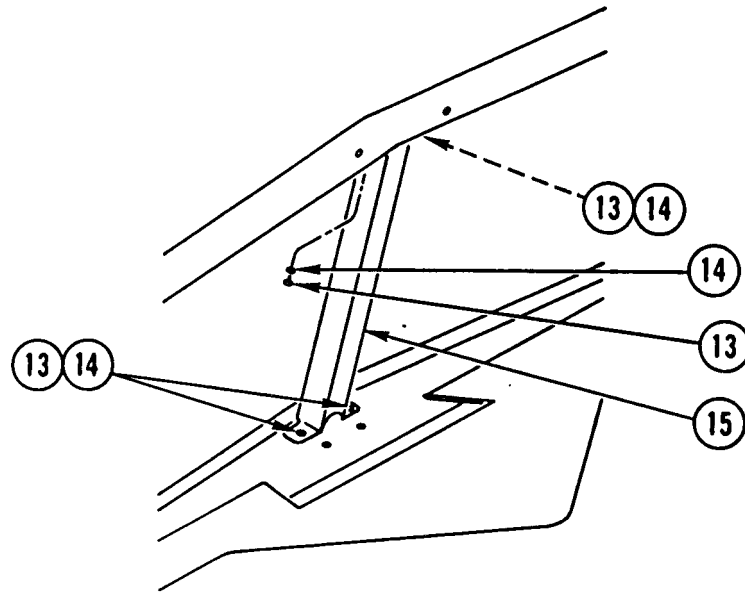

8. REMOVE FOUR SCREWS (13), FOUR WASHERS (14), AND WINDSHIELD SUPPORT (15).

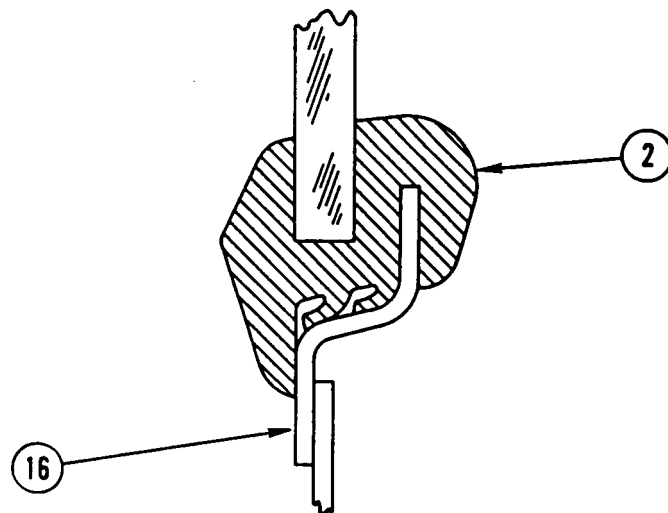

9. CUTAWAY PORTION OF SEAL (2) MOLDED AROUND CAB FLANGE (16).

WINDSHIELD REPLACEMENT (CONT)

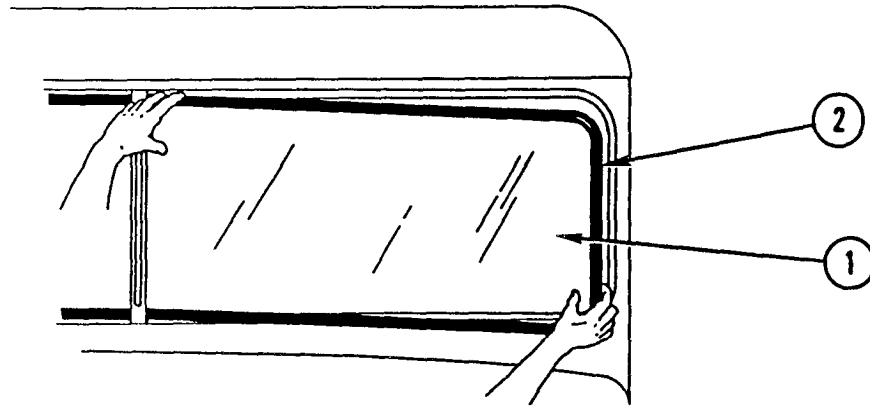

10. REMOVE EACH WINDSHIELD GLASS (1) AND SEAL (2) AS AN ASSEMBLY.
11. REMOVE SEAL (2) FROM EACH WINDSHIELD GLASS (1).

CLEANING

Use general cleaning methods to clean all parts (page 2-30).

INSPECTION

1. IF WINDSHIELD IS REMOVED DUE TO CRITERIA OUTLINED IN REMOVAL STEP 1, INSPECT CHANNEL OF SEAL (WHERE MARKED) FOR FOREIGN OBJECTS, AND INSPECT MOUNTING FLANGE OF CAB FOR IRREGULARITIES.
2. INSPECT ALL PARTS FOR WEAR OR DAMAGE.

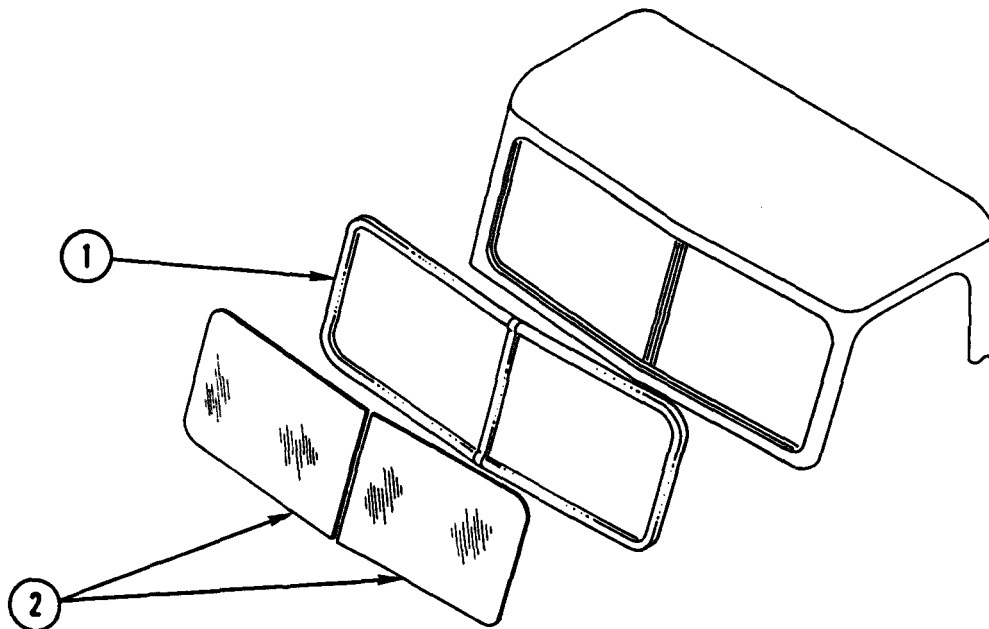
INSTALLATION**WARNING**

Wear protective gloves when handling glass. Failure to do so could result in injury to personnel.

CAUTION

- When handling windshield glass, be careful not to nick or splinter edges of glass. Chipped edges could cause cracking later.
- Do not use windshield sealant. Windshield sealant compounds are not needed and, if applied unevenly, can cause leaks resulting in water damage.

NOTE

- Manufacturer's ID number must be at lower center corner of windshield glass when installed.
 - If installing windshield glass only, perform steps 1 thru 7. If installing seal or windshield glass and seal, perform steps 8 thru 23.
 - Steps 1 thru 7 are the same for each windshield glass.
1. LUBRICATE WINDOW CHANNEL OF SEAL (1) WITH SOAP AND WATER SOLUTION.
 2. SLIDE WINDSHIELD GLASS (2) INTO WINDOW CHANNEL OF SEAL (1) AS FAR AS IT WILL GO WITHOUT FORCING.

WINDSHIELD REPLACEMENT (CONT)

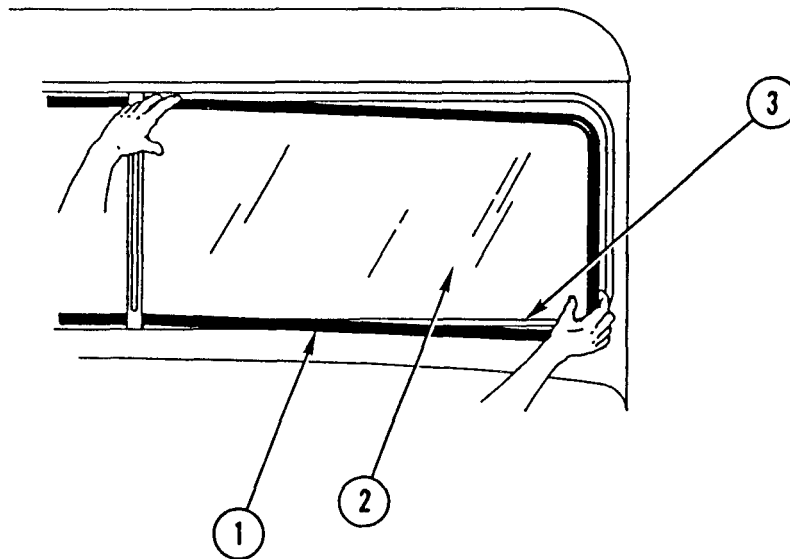

3. STRETCH SEAL (1) AROUND OUTSIDE OF WINDSHIELD GLASS (2) AND INSTALL WINDSHIELD GLASS (2) IN WINDOW CHANNEL OF SEAL (1).
4. USING WINDSHIELD PICK, ALTERNATE BETWEEN TOP AND BOTTOM OF MOUNTING FLANGES OF CAB (3) TO WORK SEAL (1) OVER MOUNTING FLANGE.
5. WITH ASSISTANT PUSHING LIGHTLY ON OUTSIDE OF WINDSHIELD GLASS (2), FINISH WORKING SEAL (1) OVER MOUNTING FLANGE OF CAB (3).

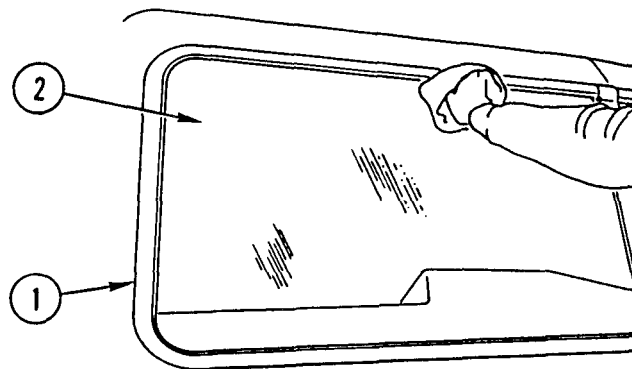

6. FINISH SEATING WINDSHIELD GLASS (2) AND SEAL (1) BY GENTLY PUSHING ALL THE WAY AROUND OUTSIDE EDGE.

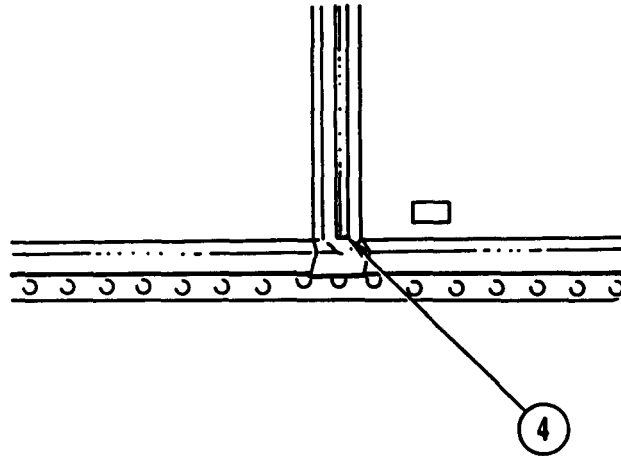

7. INSTALL NEW LOCKSTRIP (4).

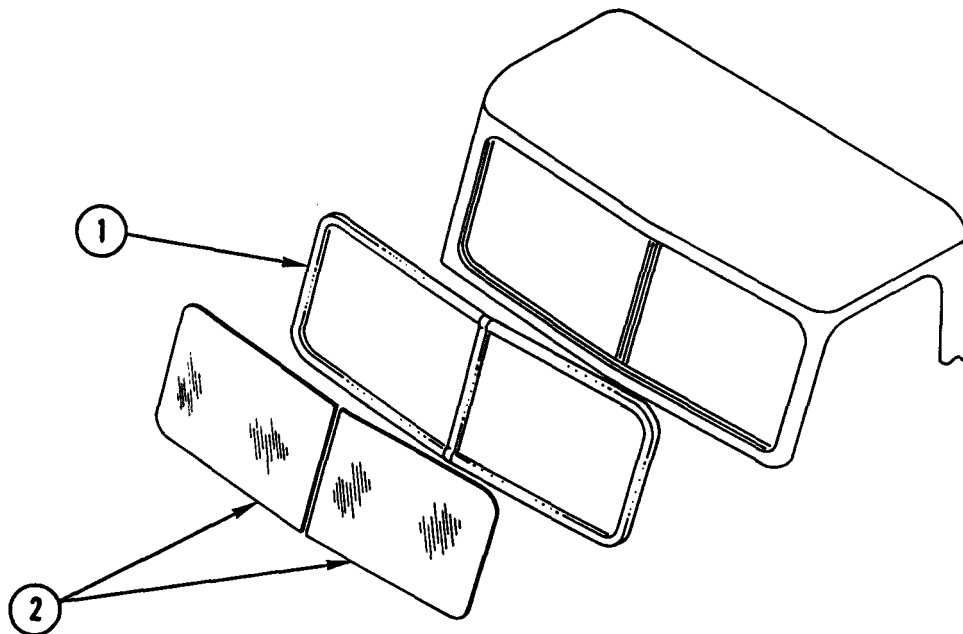

8. INSTALL EACH WINDSHIELD GLASS (2) IN CENTER STRIP OF SEAL (1) UNTIL WINDSHIELD GLASS (2) BOTTOMS OUT IN CHANNEL OF SEAL (1).
9. INSTALL OUTSIDE EDGE OF SEAL (1) ON OUTSIDE EDGE OF EACH WINDSHIELD GLASS (2) UNTIL WINDSHIELD GLASS (2) BOTTOMS OUT IN CHANNEL OF SEAL (1).
10. INSTALL REMAINDER OF SEAL (1) ON EACH WINDSHIELD GLASS (2) UNTIL WINDSHIELD GLASS (2) BOTTOMS OUT IN CHANNEL OF SEAL (1).

WINDSHIELD REPLACEMENT (CONT)

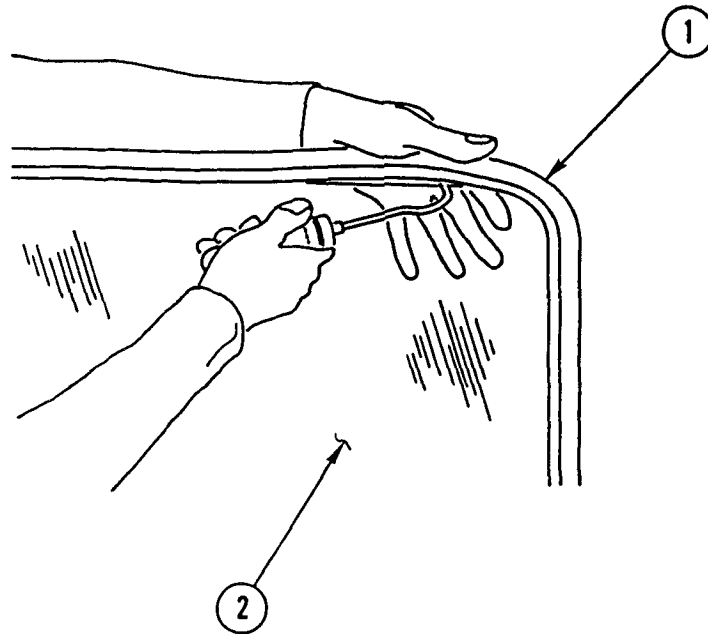

11. USING WINDSHIELD PICK, GO ALL THE WAY AROUND BETWEEN EACH WINDSHIELD GLASS (2) AND SEAL (1) TO MAKE SURE SEAL (1) IS PROPERLY SEATED.

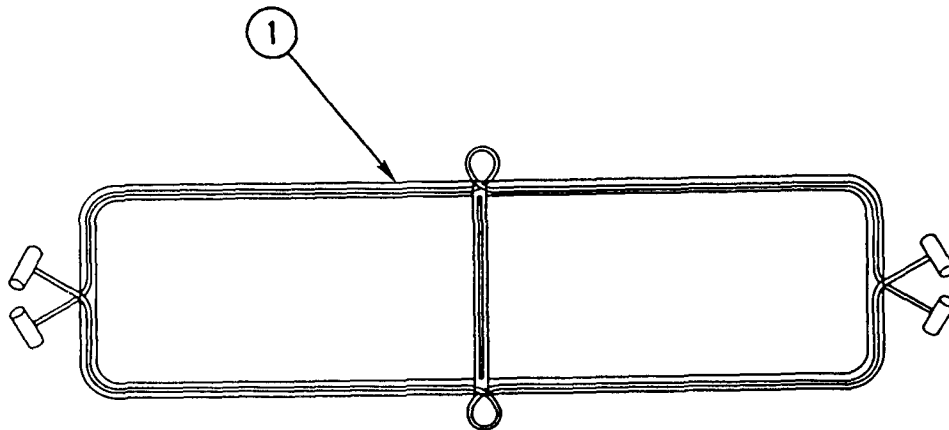

12. INSTALL TWO CORDS IN OUTSIDE GROOVE OF SEAL (1) AND LEAVE SAFETY LOOPS IN CENTER.
13. USING SOAP AND WATER SOLUTION, LUBRICATE CORD CHANNEL OF SEAL (1).

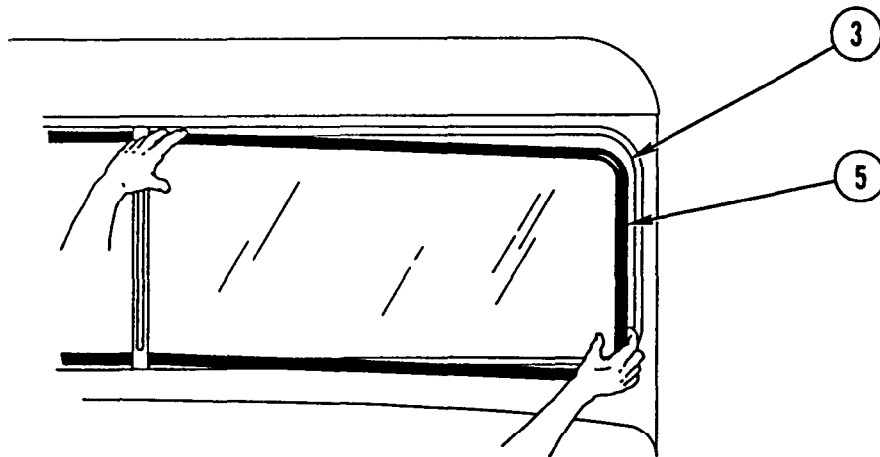

14. WET MOUNTING FLANGE OF CAB (3) WITH CLEAR WATER.
15. PLACE WINDSHIELD ASSEMBLY (5) INTO WINDSHIELD OPENING OF CAB (3).
16. WITH ASSISTANT PUSHING LIGHTLY ON BOTTOM CENTER OF WINDSHIELD ASSEMBLY (5), PULL ONE END OF LOWER CORD AROUND CORNER OF WINDSHIELD ASSEMBLY (5); GO TO OTHER SIDE AND PULL LOWER CORD AROUND OTHER CORNER OF WINDSHIELD ASSEMBLY. HAVE ASSISTANT PUSH LIGHTLY AT TOP CENTER OF WINDSHIELD ASSEMBLY. REPEAT FOR TOP CORD.

NOTE

- If cord binds or starts to tear seal, use safety loop at center and pull back toward point where cord is bound.
 - If safety loop is not needed, it will pull out when cord is pulled to seat final portion of seal.
17. WITH ASSISTANT APPLYING LIGHT PRESSURE TO CENTER OF WINDSHIELD ASSEMBLY (5), PULL BOTH ENDS OF EITHER TOP OR BOTTOM CORD ALTERNATELY UNTIL ONLY A FEW INCHES FROM CENTER (PULL BOTH ENDS AT SAME TIME). REPEAT FOR OTHER CORD.

WINDSHIELD REPLACEMENT (CONT)

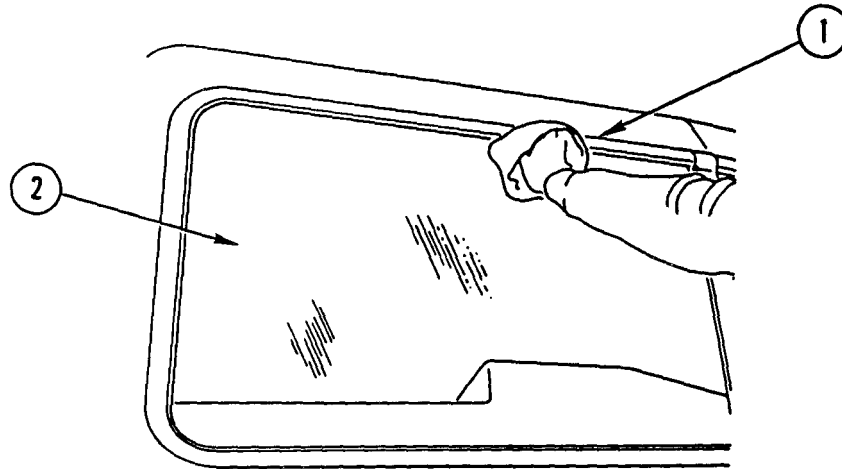

18. FINISH SEATING WINDSHIELD GLASS (2) AND SEAL (1) BY GENTLY PUSHING ALL THE WAY AROUND OUTSIDE EDGE.

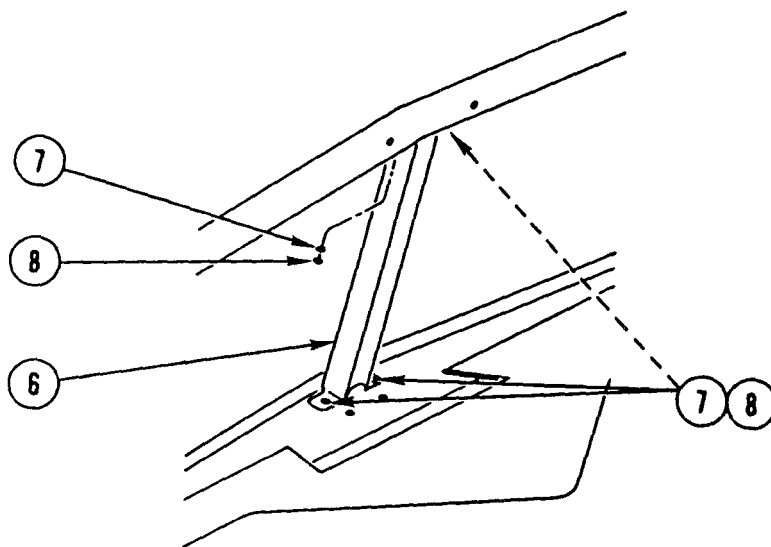

19. INSTALL WINDSHIELD SUPPORT (6), FOUR WASHERS (7), AND FOUR SCREWS (8).

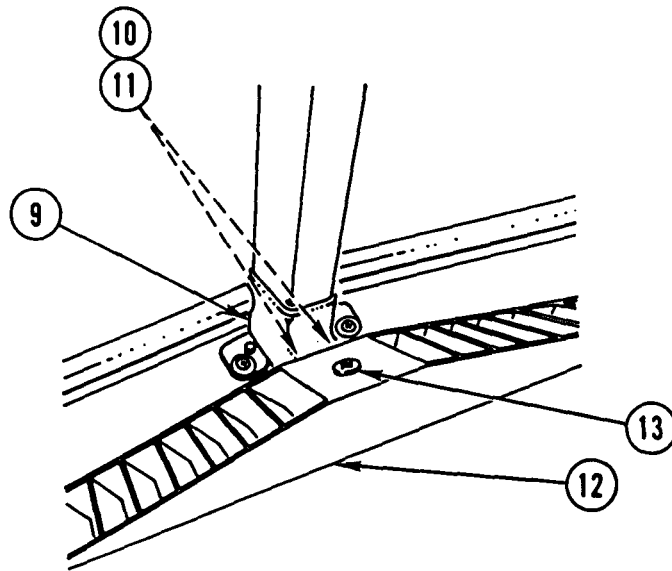

20. INSTALL COVER (9), TWO WASHERS (10), AND TWO TORX SCREWS (11).

21. INSTALL DEFROSTER VENT (12) AND TORX SCREW (13).

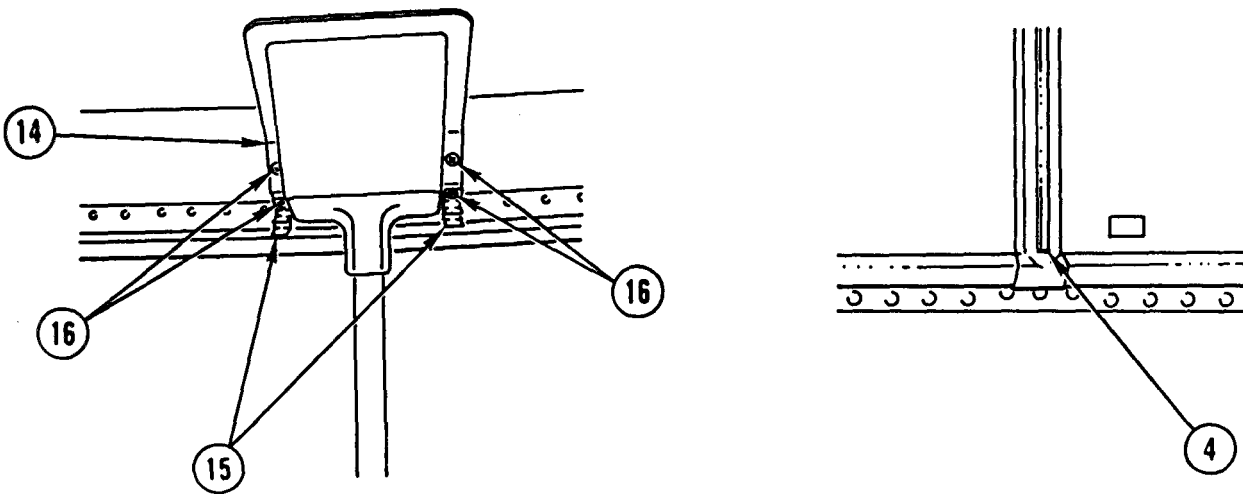

22. INSTALL COVER (14), TWO BRACKETS (15), AND FOUR TORX SCREWS (16).

23. INSTALL LOCKSTRIP (4).

NOTE

Follow-on Maintenance:
Install windshield wiper and wiper arms (TM 9-2320-363-20).

CAB REPLACEMENT

This task covers: a. Removal b. Cleaning c. Inspection d. Installation

INITIAL SETUP

Applicable Configuration:

M915A2

Tools and Special Equipment:

Tool Kit, SC 5180-90-CL-N05
Cab Sling, J39520

Materials/Parts:

Nut, Kep

Personnel Required: (3)

References:

TM 9-2320-363-20

Equipment Condition:

Reference	Condition Description
Page 10-89	Cab Doors Removed
TM 9-2320-363-20	Muffler and Exhaust Stack Removed
TM 9-2320-363-20	Exterior Grabhandles Removed
TM 9-2320-363-20	Fender Extensions Removed
TM 9-2320-363-20	Hood Latches Removed
TM 9-2320-363-20	Utility Lights Removed
TM 9-2320-363-20	Clearance Lights Removed
TM 9-2320-363-20	Windshield Wiper Linkage Removed
TM 9-2320-363-20	Voltage Regulator Removed
TM 9-2320-363-20	Dual Voltage Control Removed
TM 9-2320-363-20	Starter Regulator Removed

Equipment Condition (Cont):

Reference	Condition Description
TM 9-2320-363-20	Foot Brake Valve Removed
Page 10-84	Rear Window Removed
Page 10-52	Windshield Removed
TM 9-2320-363-20	Radio Mounting Bracket Removed
TM 9-2320-363-20	Transmission Shift Control Removed
TM 9-2320-363-20	Floor Mats Removed
TM 9-2320-363-20	Personnel Heater Removed
Page 10-36	Air Ducts Removed
TM 9-2320-363-20	Head Liners Removed
TM 9-2320-363-20	Rotating Warning Light Bracket Removed
TM 9-2320-363-20	Sunvisors Removed
TM 9-2320-363-20	Air Horn and Valve Removed
TM 9-2320-363-20	Interior Grabhandle Removed
TM 9-2320-363-20	Cab Liners Removed
TM 9-2320-363-20	Electronic Throttle Removed
TM 9-2320-363-20	Steering Column Support Bracket Removed
TM 9-2320-363-20	Brake Pedal Removed
Page 4-36	Overhead Cab Wiring Harness Removed
Page 4-6	Chassis Wiring Harness Removed
Page 4-20	STE/ICE Wiring Harness Removed

Equipment Condition (Cont):

Reference	Condition Description
TM 9-2320-363-20	Air Tubes Removed
TM 9-2320-363-20	Anti-Lock Brake System (ABS) Electronic Control Unit Removed
TM 9-2320-363-20	Anti-Lock Brake System (ABS) Fuse and Relay Panel Removed
Page 4-42	Cab Anti-Lock Brake System (ABS) Wiring Harness Removed

General Safety Instructions:

WARNING
 Cab assembly weighs 1,100 lb (499 kg). Use hoist with lifting capacity of 1,400 lb (636 kg) to support cab assembly. Failure to do so could result in injury to personnel and/or damage to cab assembly.

REMOVAL

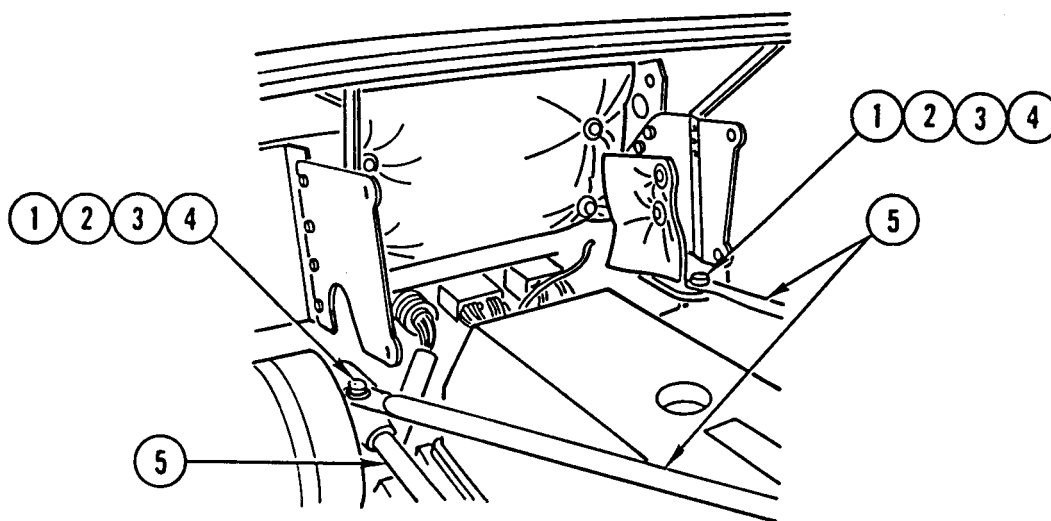

1. REMOVE TWO NUTS (1), TWO WASHERS (2), TWO BOLTS (3), AND TWO WASHERS (4) AND SWING THREE RADIATOR SUPPORT RODS (5) OUT OF THE WAY.

CAB REPLACEMENT (CONT)

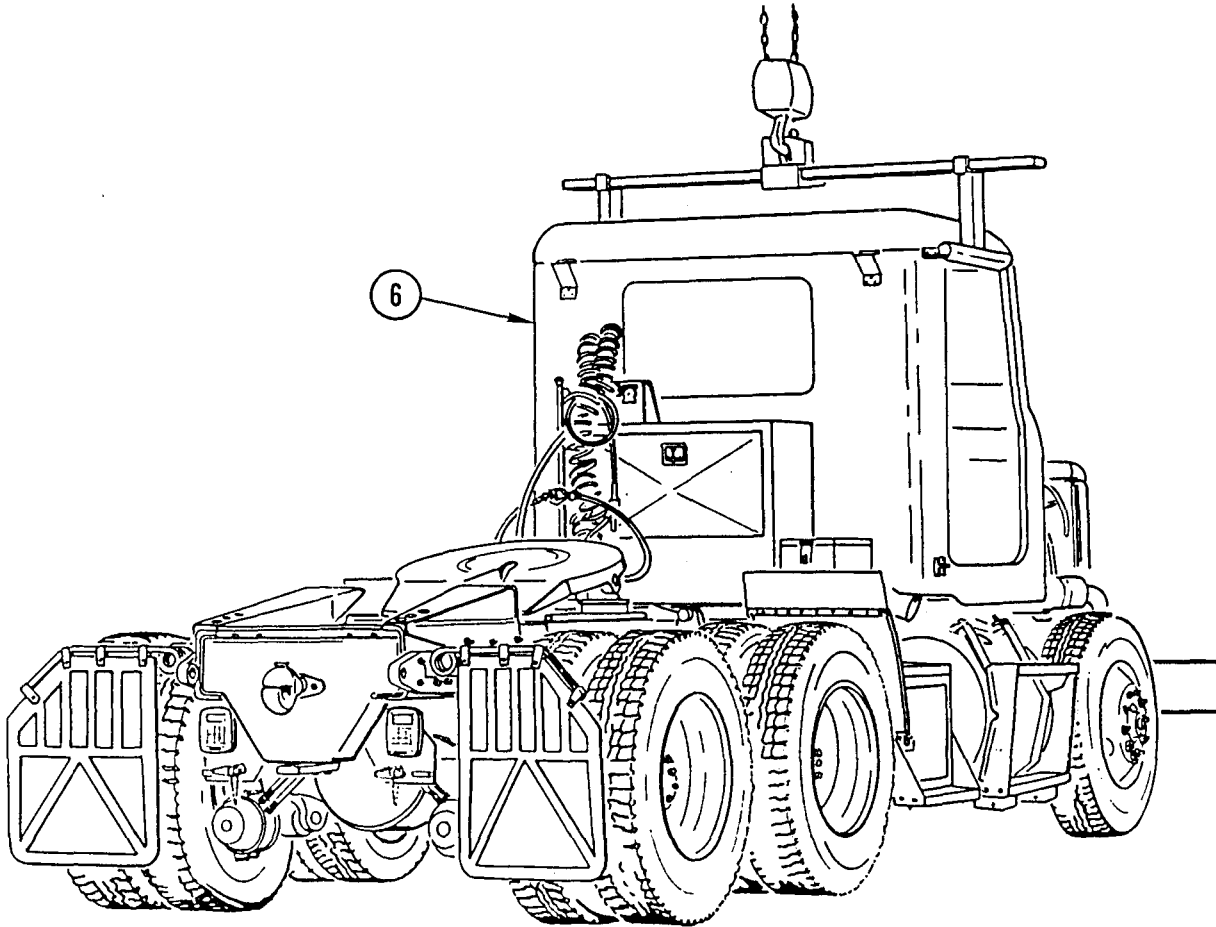

WARNING

Cab assembly weighs 1,100 lb (499 kg). Use hoist with lifting capacity of 1,400 lb (636 kg) to support cab assembly. Failure to do so could result in injury to personnel and/or damage to cab assembly.

2. ATTACH CAB SLING AND HOIST TO CAB ASSEMBLY (6) AND REMOVE ALL SLACK FROM CHAIN.

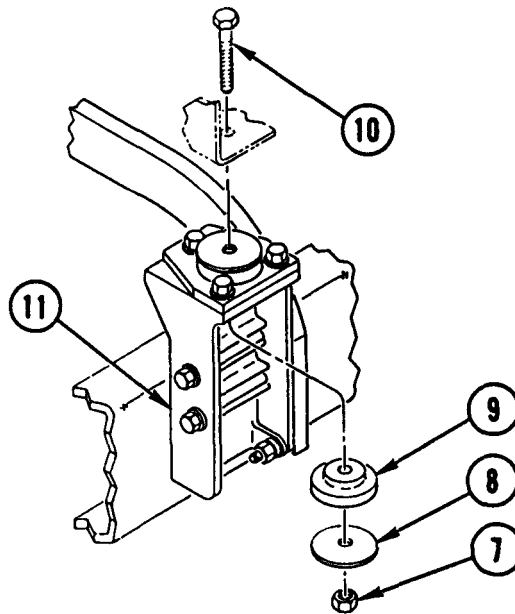

3. REMOVE TWO NUTS (7), TWO WASHERS (8), TWO BUSHINGS (9), AND TWO BOLTS (10) FROM FRONT CAB MOUNT (11).

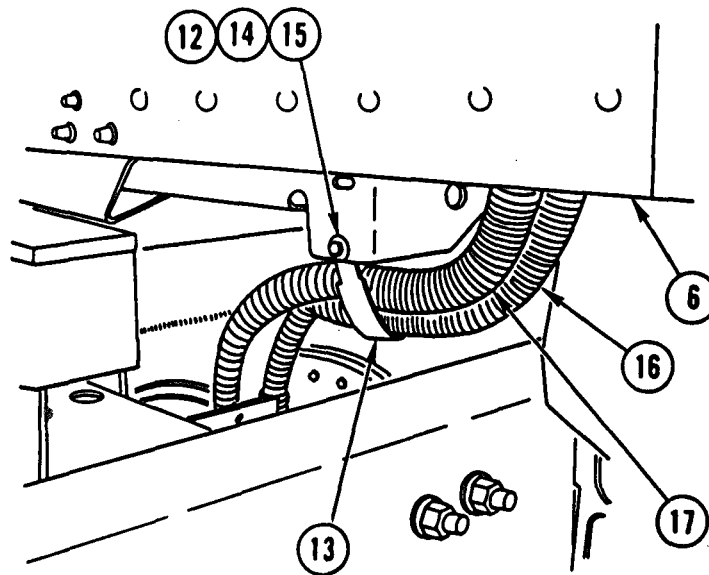

4. REMOVE KEP NUT (12), CLAMPS (13), SCREW (14), AND WASHER (15). DISCARD KEP NUT.
5. CAREFULLY PULL TWO WIRING HARNESSSES (16 AND 17) FROM CAB ASSEMBLY (6).

CAB REPLACEMENT (CONT)

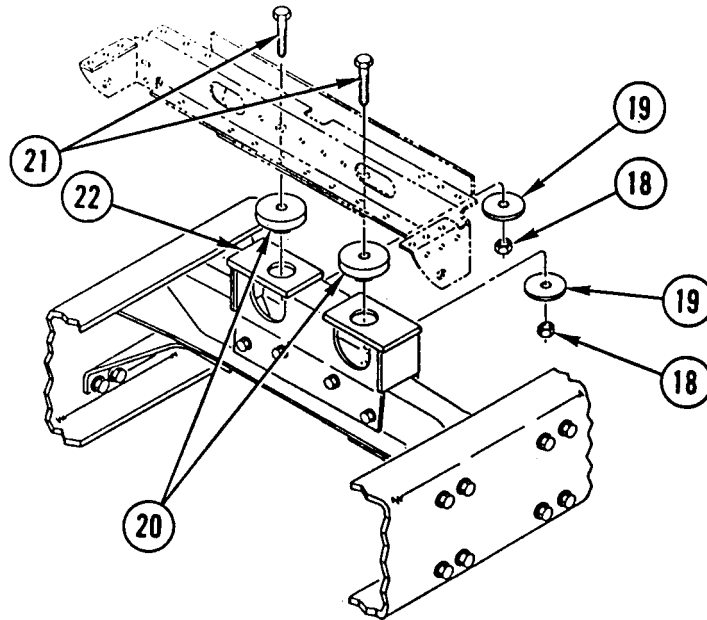

6. REMOVE TWO NUTS (18), TWO WASHERS (19), TWO BUSHINGS (20), AND TWO BOLTS (21) FROM REAR CAB MOUNT (22).

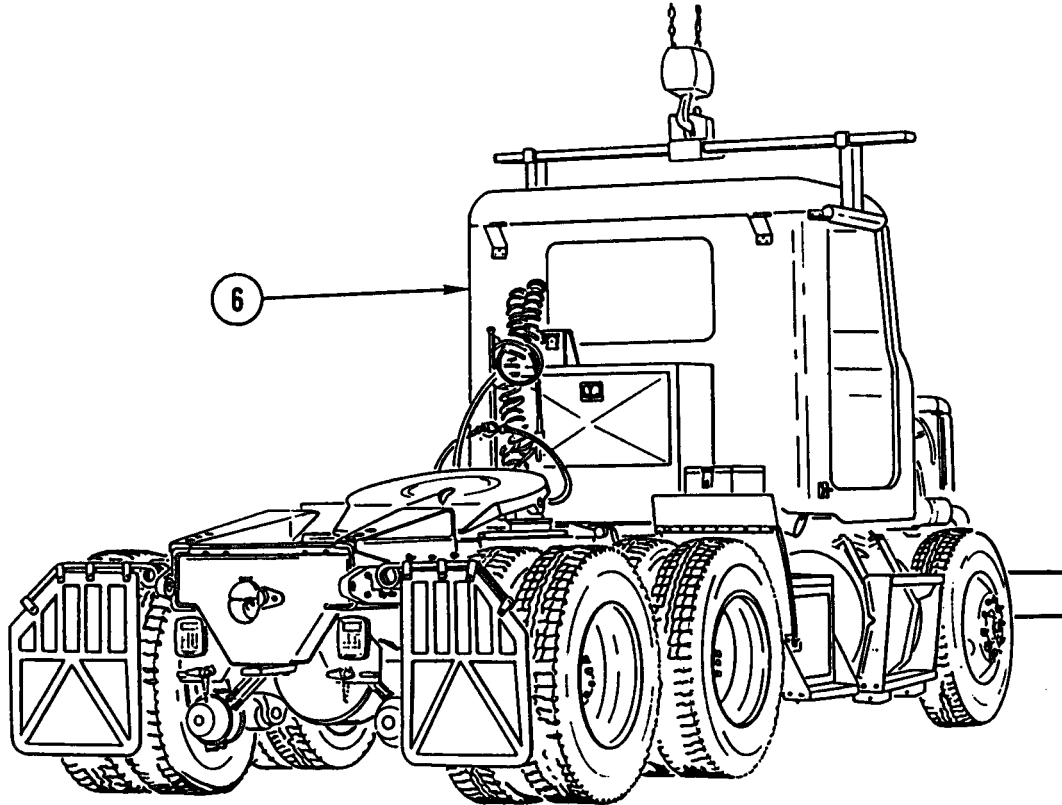

CAUTION

Lift cab slowly and check for parts that may still be connected to cab and vehicle structure. Failure to do so could result in damage to equipment.

7. REMOVE CAB ASSEMBLY (6).

CLEANING

Use general cleaning methods to clean all parts (page 2-30).

INSPECTION

Inspect all parts for wear or damage.

CAB REPLACEMENT (CONT)

INSTALLATION

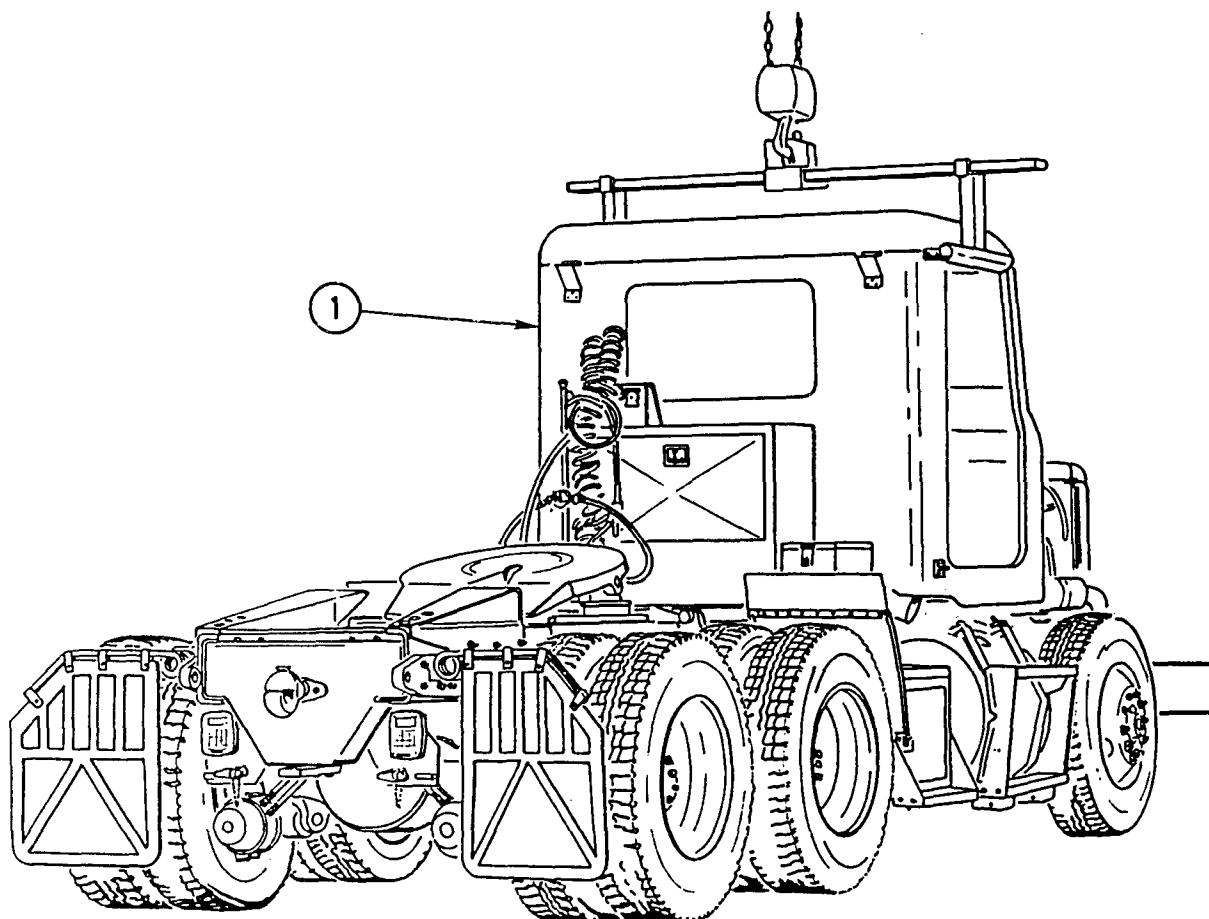

WARNING

Cab assembly weighs 1,100 lb (499 kg), Use hoist with lifting capacity of 1,400 lb (636 kg) to support cab assembly. Failure to do so could result in injury to personnel and/or damage to cab assembly.

CAUTION

Check under side of cab as it is lowered in place. Make sure nothing is between cab and frame structure. Failure to do so could result in damage to equipment.

1. ATTACH CAB SLING AND HOIST TO CAB ASSEMBLY (1) AND INSTALL CAB ASSEMBLY (1).

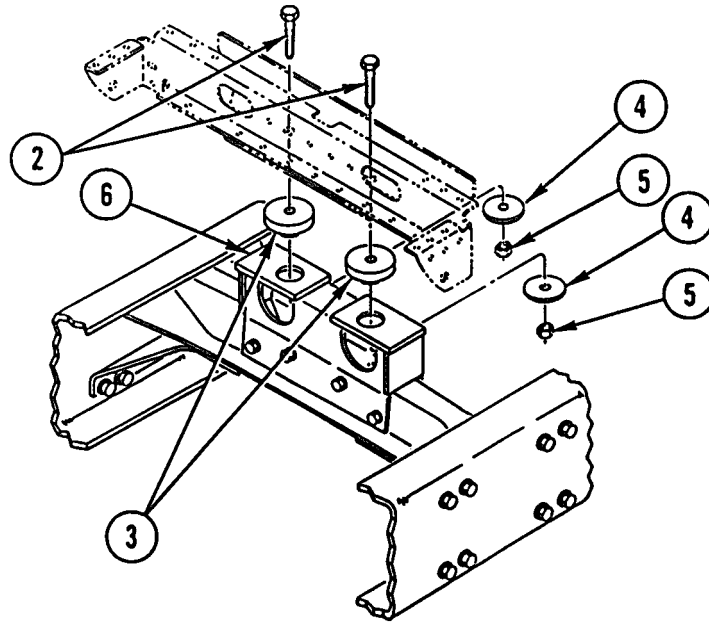

2. INSTALL TWO BOLTS (2), TWO BUSHINGS (3), TWO WASHERS (4), AND TWO NUTS (5) IN REAR CAB MOUNT (6).

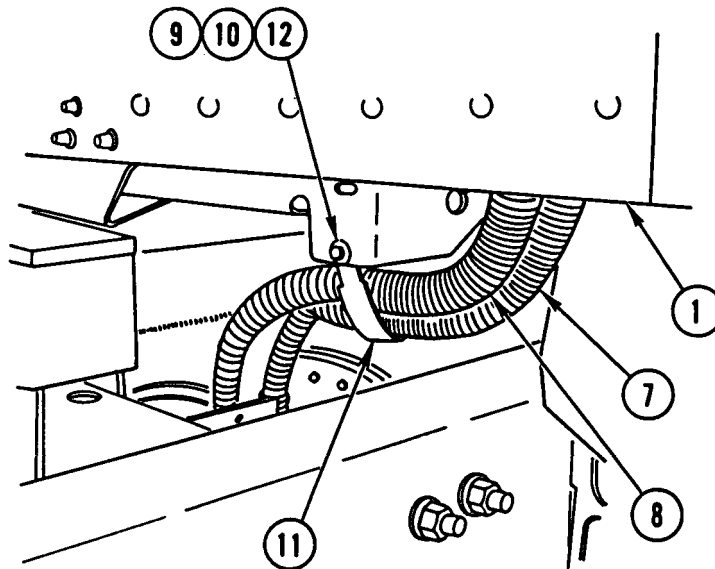

3. CAREFULLY INSTALL TWO WIRING HARNESSSES (7 AND 8) IN CAB ASSEMBLY (1).
4. INSTALL WASHER (9), SCREW (10), CLAMP (11), AND NEW KEP NUT (12).

CAB REPLACEMENT (CONT)

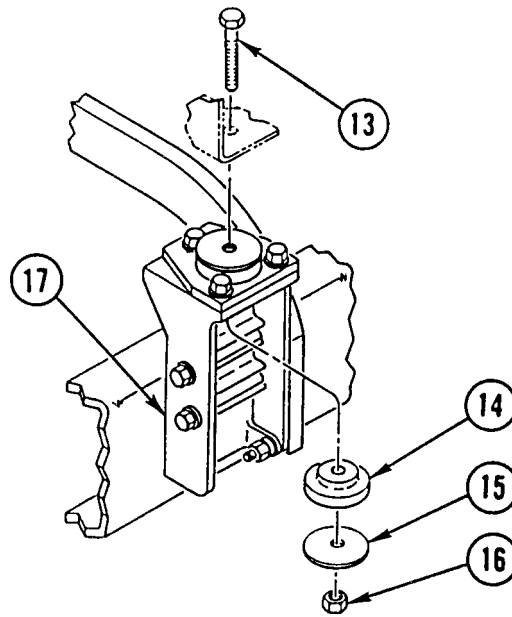

5. INSTALL TWO BOLTS (13), TWO BUSHINGS (14), TWO WASHERS (15), AND TWO NUTS (16) IN FRONT CAB MOUNT (17).

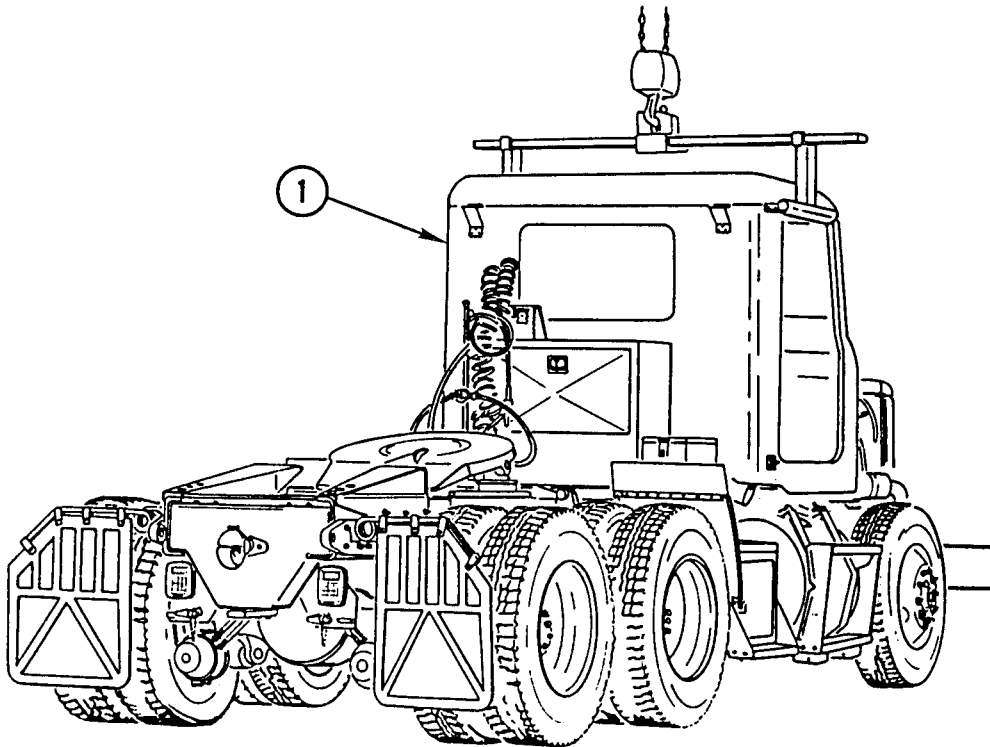

6. REMOVE CAB SLING AND HOIST FROM CAB ASSEMBLY (1).

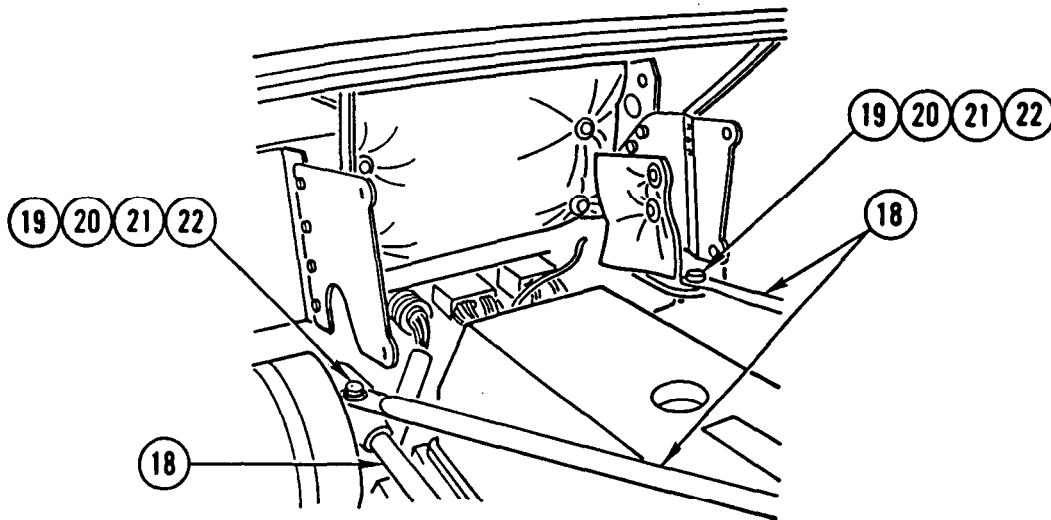

7. SWING THREE RADIATOR SUPPORT RODS (18) INTO PLACE AND INSTALL TWO WASHERS (19), TWO BOLTS (20), TWO WASHERS (21), AND TWO NUTS (22).

NOTE

Follow-on Maintenance:

- Install cab Anti-Lock Brake System (ABS) wiring harness (page 4-42).
- Install Anti-Lock Brake System (ABS) fuse and relay panel (TM 9-2320-363-20).
- Install Anti-Lock Brake System (ABS) electronic control unit (TM 9-2320-363-20).
- install air tubes (TM 9-2320-363-20).
- install STE/ICE wiring harness (page 4-20).
- Install chassis wiring harness (page 4-6).
- Install overhead cab wiring harness (page 4-36).
- Install brake pedal (TM 9-2320-363-20).
- Install steering column support bracket (TM 9-2320-363-20).
- Install electronic throttle (TM 9-2320-363-20).
- Install cab liners (TM 9-2320-363-20).
- Install interior grabhandle (TM 9-2320-363-20).
- Install air horn and valve (TM 9-2320-363-20).
- Install sunvisors (TM 9-2320-363-20).
- Install rotating warning light bracket (TM 9-2320-363-20).
- Install head liners (TM 9-2320-363-20).
- Install air ducts (page 10-36).
- Install personnel heater (TM 9-2320-363-20).
- Install floor mats (TM 9-2320-363-20).
- Install transmission shift control (TM 9-2320-363-20).
- Install radio mounting bracket (M915A2) (TM 9-2320-363-20).
- Install windshield (page 10-52).
- Install rear window (page 10-84).
- Install foot brake valve (TM 9-2320-363-20).
- Install starter regulator (TM 9-2320-363-20).
- Install dual voltage control (TM 9-2320-363-20).
- Install voltage regulator (TM 9-2320-363-20).

TM 9-2320-363-34-1

Install windshield wiper linkage (TM 9-2320-363-20).
Install clearance lights (TM 9-2320-363-20).
Install utility lights (TM 9-2320-363-20).
Install hood latches (TM 9-2320-363-20).
install fender extensions (TM 9-2320-363-20)
Install exterior grabhandles (TM 9-2320-363-20).
Install muffler and exhaust stack (TM 9-2320-363-20).
Install cab doors (page 10-89).

C A B R E P L A C E M E N T

This task covers: a. Removal b. Cleaning c. Inspection d. Installation

INITIAL SETUP

Applicable Configuration:

All except M915A2

Tools and Special Equipment:

Tool Kit, SC 5180-90-CL-N05
Cab Sling, J39520

Personnel Required: (3)

References:

TM 9-2320-363-20

Equipment Condition:

Reference	Condition Description
-----------	-----------------------

Page 10-89

Cab Doors Removed

TM 9-2320-363-20

Muffler and Exhaust Stack Removed

TM 9-2320-363-20

Exterior Grabhandles Removed

TM 9-2320-363-20

Fender Extensions Removed

TM 9-2320-363-20

Hood Latches Removed

TM 9-2320-363-20

Utility Lights Removed

TM 9-2320-363-20

Clearance Lights Removed

TM 9-2320-363-20

Windshield Wiper Linkage Removed

TM 9-2320-363-20

Voltage Regulator Removed

TM 9-2320-363-20

Dual Voltage Control Removed

TM 9-2320-363-20

Starter Regulator Removed

TM 9-2320-363-20

Foot Brake Valve Removed

Page 10-84

Rear Window Removed

Equipment Condition (Cont):

Reference

Condition Description

Page 10-52

Windshield Removed

TM 9-2320-363-20

Transmission Shift Control Removed

TM 9-2320-363-20

Transfer Case Shift Control Removed

TM 9-2320-363-20

Floor Mats Removed

TM 9-2320-363-20

Personnel Heater Removed

Page 10-36

Air Ducts Removed

TM 9-2320-363-20

Head Liners Removed

TM 9-2320-363-20

Rotating Warning Light Bracket Removed

TM 9-2320-363-20

Sunvisors Removed

TM 9-2320-363-20

Air Horn and Valve Removed

TM 9-2320-363-20

Interior Grabhandle Removed

TM 9-2320-363-20

Cab Liners Removed

TM 9-2320-363-20

Electronic Throttle Removed

TM 9-2320-363-20

Steering Column Support Bracket Removed

TM 9-2320-363-20

Brake Pedal Removed

Page 4-36

Overhead Cab Wiring Harness Removed

Page 4-6

Chassis Wiring Harness Removed

Page 4-20

STE/ICE Wiring Harness Removed

TM 9-2320-363-20

Air Tubes Removed

CAB REPLACEMENT (CONT)

General Safety Instructions:

WARNING

Cab assembly weighs 1,100 lb (499 kg). Use hoist with lifting capacity of 1,400 lb (636 kg) to support cab assembly. Failure to do so could result in injury to personnel and/or damage to cab assembly.

REMOVAL

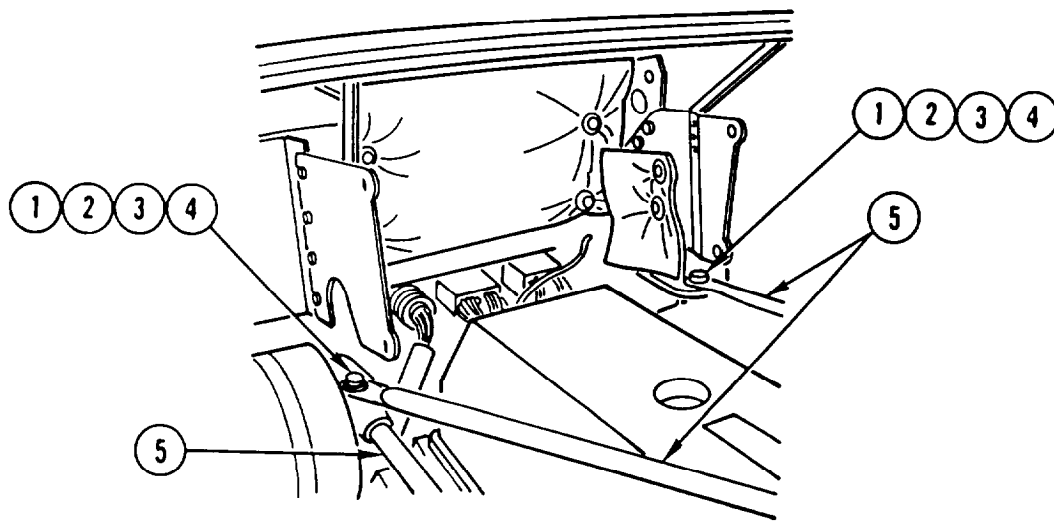

1. REMOVE TWO NUTS (1), TWO WASHERS (2), TWO BOLTS (3), AND TWO WASHERS (4) AND SWING THREE RADIATOR SUPPORT RODS (5) OUT OF THE WAY.

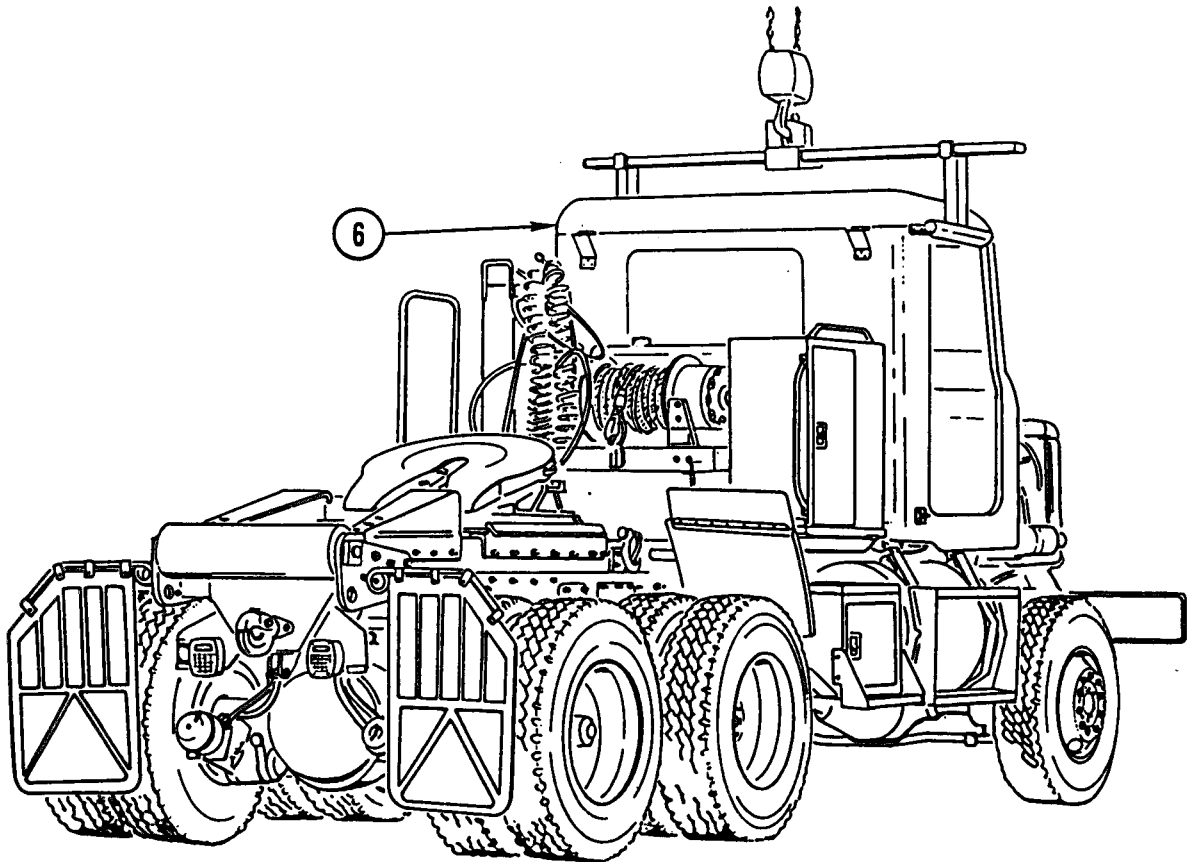

WARNING

Cab assembly weighs 1,100 lb (499 kg). Use hoist with lifting capacity of 1,400 lb (636 kg) to support cab assembly. Failure to do so could result in injury to personnel and/or damage to cab assembly.

2. ATTACH CAB SLING AND HOIST TO CAB ASSEMBLY (6) AND REMOVE ALL SLACK FROM CHAIN.

CAB REPLACEMENT (CONT)

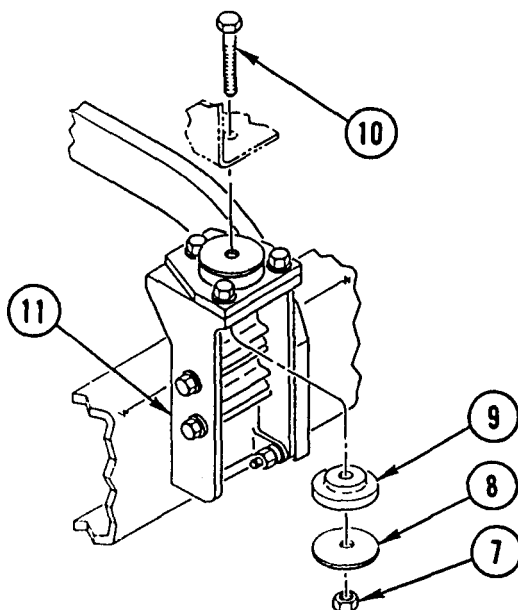

3. REMOVE TWO NUTS (7), TWO WASHERS (8), TWO BUSHINGS (9), AND TWO BOLTS (10) FROM FRONT CAB MOUNT (11).

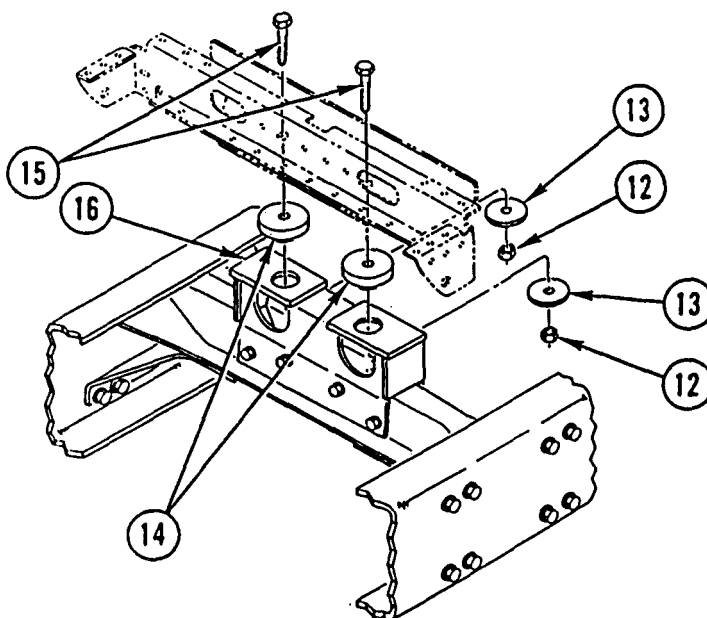

4. REMOVE TWO NUTS (12), TWO WASHERS (13), TWO BUSHINGS (14), AND TWO BOLTS (15) FROM REAR CAB MOUNT (16).

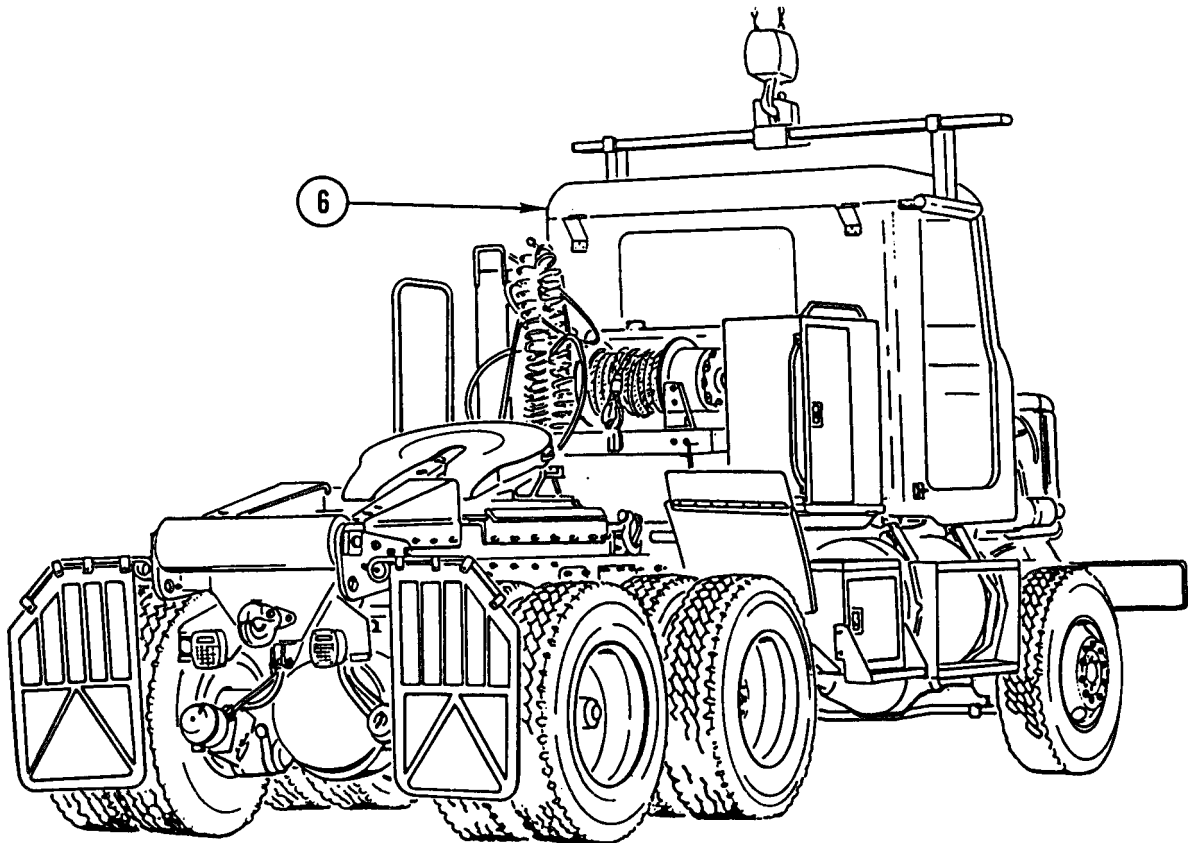

CAUTION

Lift cab slowly and check for parts that may still be connected to cab and vehicle structure. Failure to do so could result in damage to equipment.

5. REMOVE CAB ASSEMBLY (6).

CLEANING

Use general cleaning methods to clean all parts (page 2-30).

INSPECTION

Inspect all parts for wear or damage.

CAB REPLACEMENT (CONT)

INSTALLATION

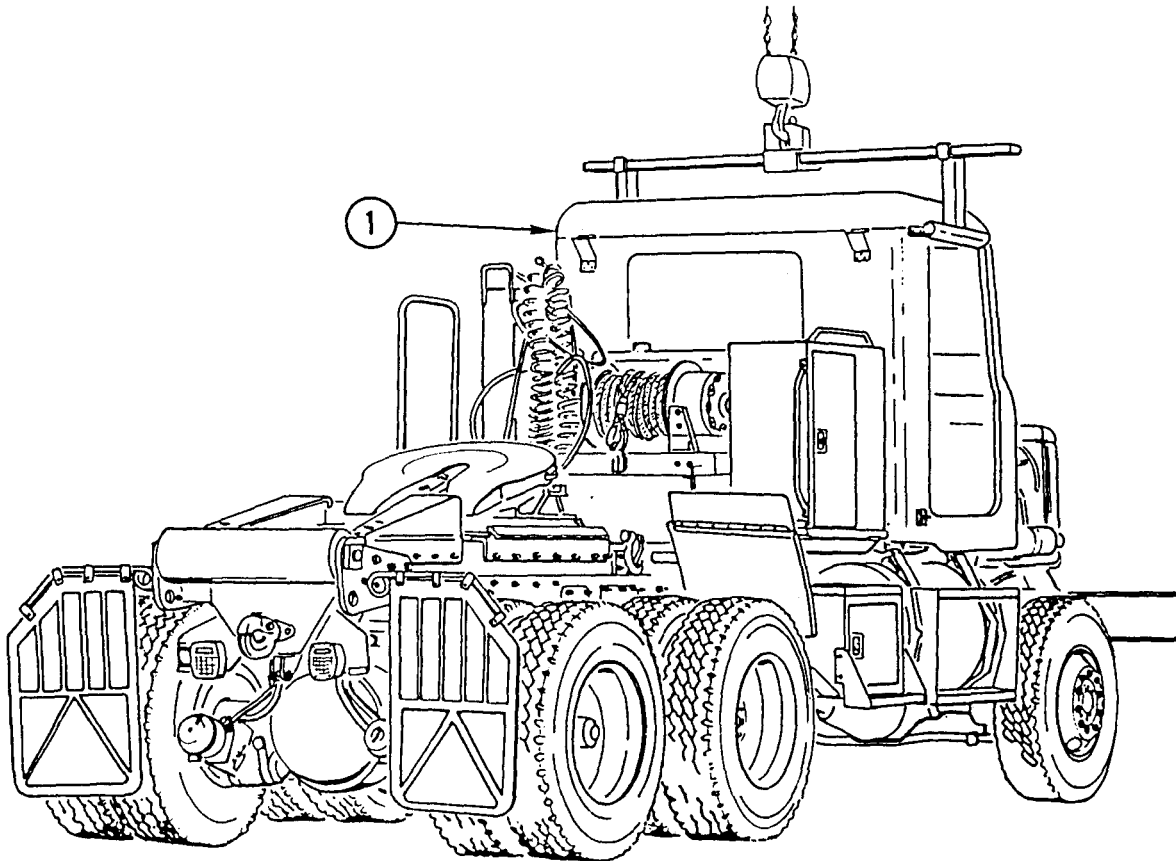

WARNING

Cab assembly weighs 1,100 lb (499 kg). Use hoist with lifting capacity of 1,400 lb (636 kg) to support cab assembly. Failure to do so could result in injury to personnel and/or damage to cab assembly.

CAUTION

Check underside of cab as it is lowered into place. Make sure nothing is between cab and frame structure. Failure to do so could result in damage to equipment.

1. ATTACH CAB SLING AND HOIST TO CAB ASSEMBLY (1) AND INSTALL CAB ASSEMBLY (1).

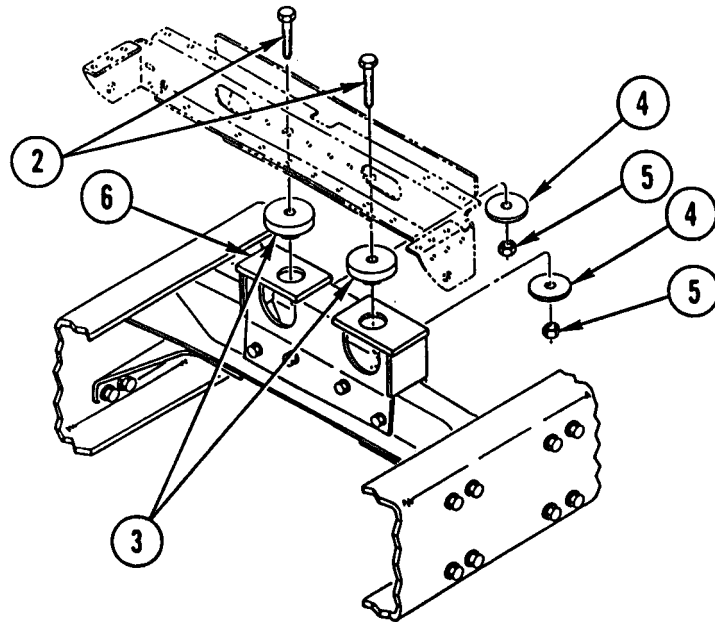

2. INSTALL TWO BOLTS (2), TWO BUSHINGS (3), TWO WASHERS (4), AND TWO NUTS (5) IN REAR CAB MOUNT (6).

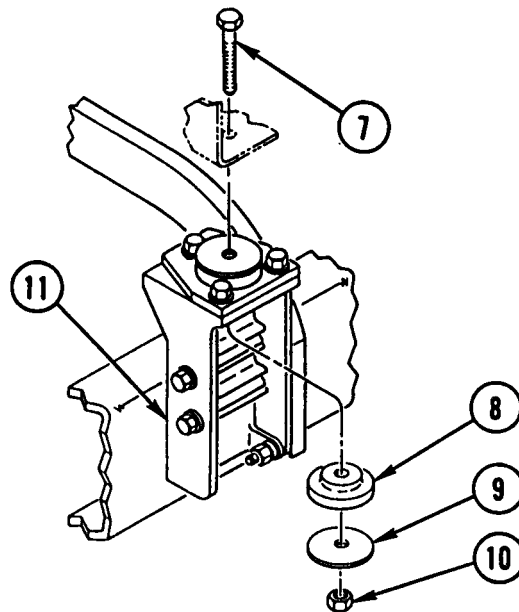

3. INSTALL TWO BOLTS (7), TWO BUSHINGS (6), TWO WASHERS (9), AND TWO NUTS (10) IN FRONT CAB MOUNT (11).

CAB REPLACEMENT (CONT)

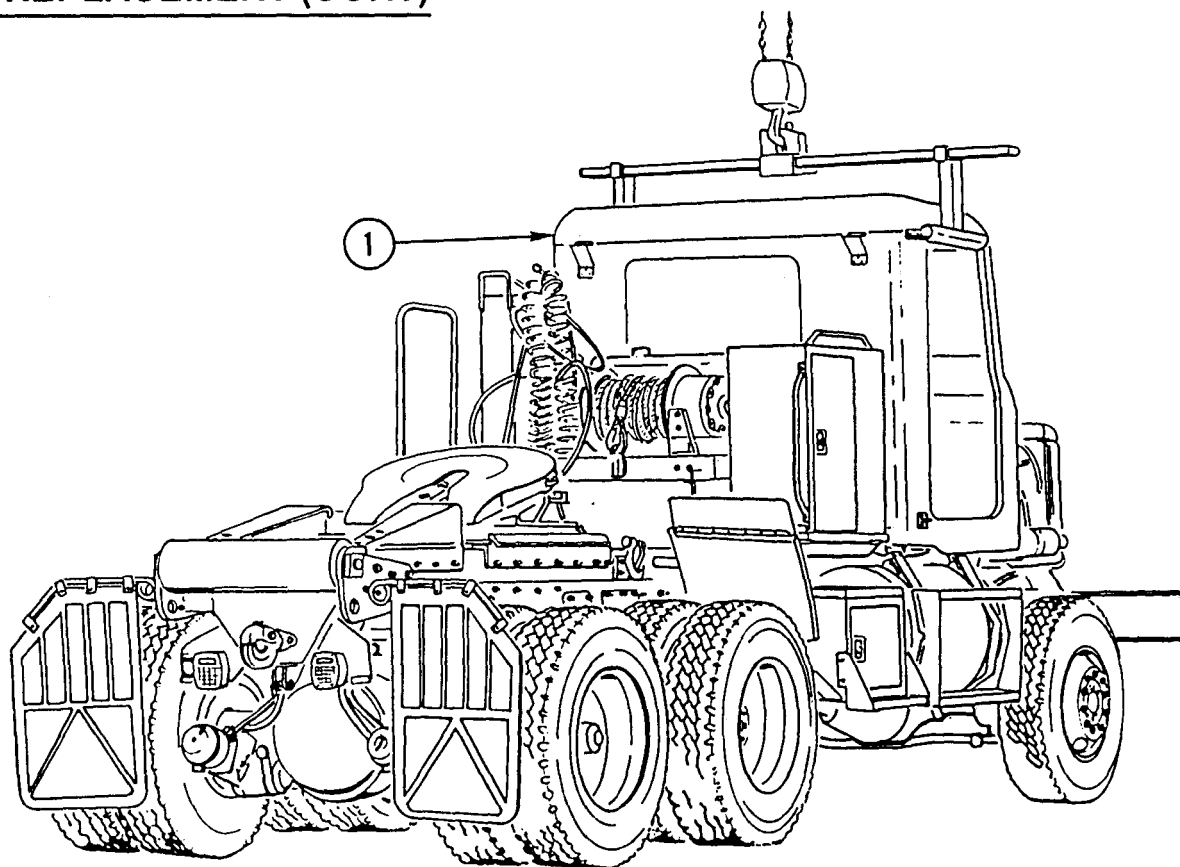

4. REMOVE CAB SLING AND HOIST FROM CAB ASSEMBLY (1).

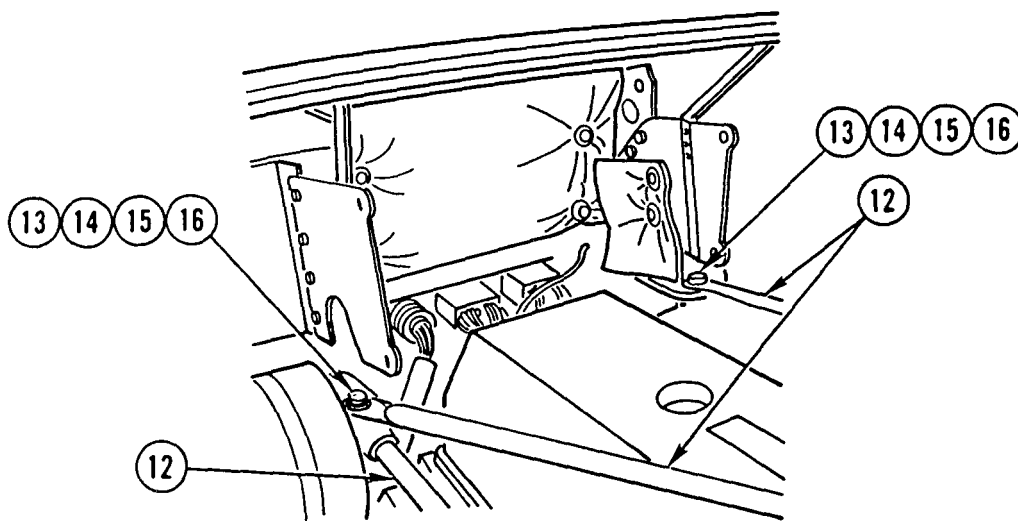

5. SWING THREE RADIATOR SUPPORT RODS (12) INTO PLACE AND INSTALL TWO WASHERS (13), TWO BOLTS (14), TWO WASHERS (15), AND TWO NUTS (16).

NOTE

Follow-on Maintenance:

Install air tubes (TM 9-2320-363-20),
Install STE/ICE wiring harness (page 4-20).
Install chassis wiring harness (page 4-6).
Install overhead cab wiring harness (page 4-36).
Install brake pedal (TM 9-2320-363-20).
Install steering column support bracket (TM 9-2320-363-20).
Install electronic throttle (TM 9-2320-363-20).
Install cab liners (TM 9-2320-363-20).
Install interior grabhandle (TM 9-2320-363-20).
Install air horn and valve (TM 9-2320-363-20).
Install sunvisors (TM 9-2320-363-20).
Install rotating warning light bracket (TM 9-2320-363-20).
Install head liners (TM 9-2320-363-20).
Install air ducts (page 10-36).
Install personnel heater (TM 9-2320-363-20).
Install floor mats (TM 9-2320-363-20).
Install transfer case shift control (TM 9-2320-363-20).
Install transmission shift control (TM 9-2320-363-20).
Install windshield (page 10-52).
Install rear window (page 10-84).
Install foot brake valve (TM 9-2320-363-20).
Install starter regulator (TM 9-2320-363-20).
Install dual voltage control (TM 9-2320-363-20).
Install voltage regulator (TM 9-2320-363-20).
Install windshield wiper linkage (TM 9-2320-363-20).
Install clearance lights (TM 9-2320-363-20).
Install utility lights (TM 9-2320-363-20).
Install hood latches (TM 9-2320-363-20).
Install fender extensions (TM 9-2320-363-20).
Install exterior grabhandles (TM 9-2320-363-20).
Install muffler and exhaust stack (TM 9-2320-363-20).
Install cab doors (page 10-89).

REAR WINDOW REPLACEMENT

This task covers: a. Removal b. Cleaning c. Inspection d. Installation

INITIAL SETUP

Tools and Special Equipment:

Tool Kit, SC 5180-90-CL-N05
Tool Kit, SC 4940-95-CL-A18

Materials/Parts:

Compound, Sealing Appendix B, Item 16

Personnel Required: (2)

General Safety Instructions:

WARNING

Wear protective gloves when handling glass. Failure to do so could result in injury to personnel.

REMOVAL

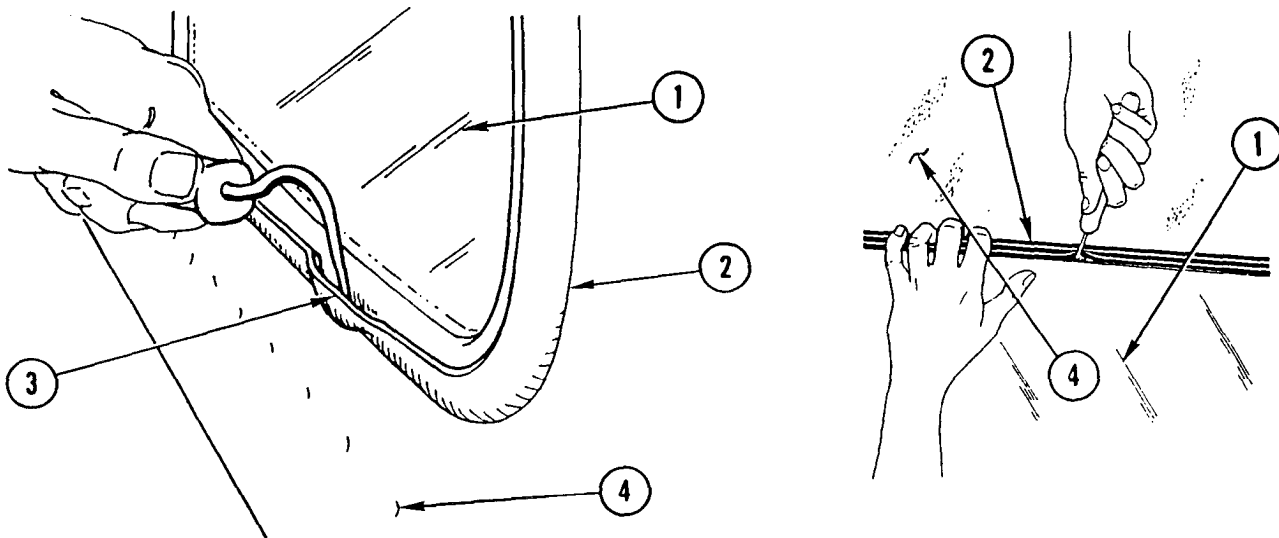

NOTE

If removing rear window glass only, perform steps 1 thru 3. If removing rear window glass and seal, perform steps 1 thru 5.

1. IF REAR WINDOW GLASS (1) IS CRACKED DUE TO ANY CAUSE OTHER THAN BEING HIT BY A FLYING OBJECT, MARK RUBBER EXTRUSION (2) AT LOCATION OF CRACK.
2. USING WINDSHIELD PICK, RELEASE LOCKING STRIP (3) FROM RUBBER EXTRUSION (2).

WARNING

Wear protective gloves when handling glass. Failure to do so could result in injury to personnel.

CAUTION

When handling glass, be careful not to nick or splinter edges. Chipped edges could cause cracking later.

3. APPLY PRESSURE TO ONE EDGE OF REAR WINDOW GLASS (1) FROM INSIDE CAB (4). USING WINDSHIELD PICK, LIFT AND REMOVE REAR WINDOW GLASS (1) OUT OF RUBBER EXTRUSION (2).
4. REMOVE RUBBER EXTRUSION (2) FROM CAB (4).

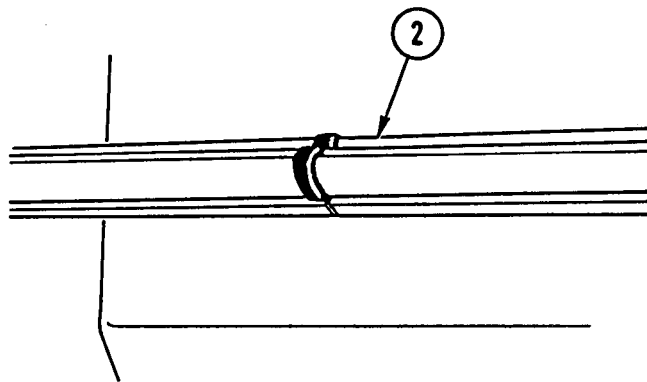

5. REMOVE SEALING COMPOUND FROM BETWEEN ENDS OF RUBBER EXTRUSION (2).

CLEANING

Use general cleaning methods to clean all parts (page 2-30).

INSPECTION

1. IF REAR WINDOW GLASS HAS BEEN REMOVED UNDER CRITERIA OUTLINED IN REMOVAL STEP 1, INSPECT CHANNEL OF RUBBER EXTRUSION WHERE MARKED FOR FOREIGN OBJECTS. INSPECT MOUNTING FLANGE OF CAB FOR IRREGULARITIES.
2. INSPECT ALL PARTS FOR WEAR OR DAMAGE.

REAR WINDOW REPLACEMENT (CONT)

INSTALLATION

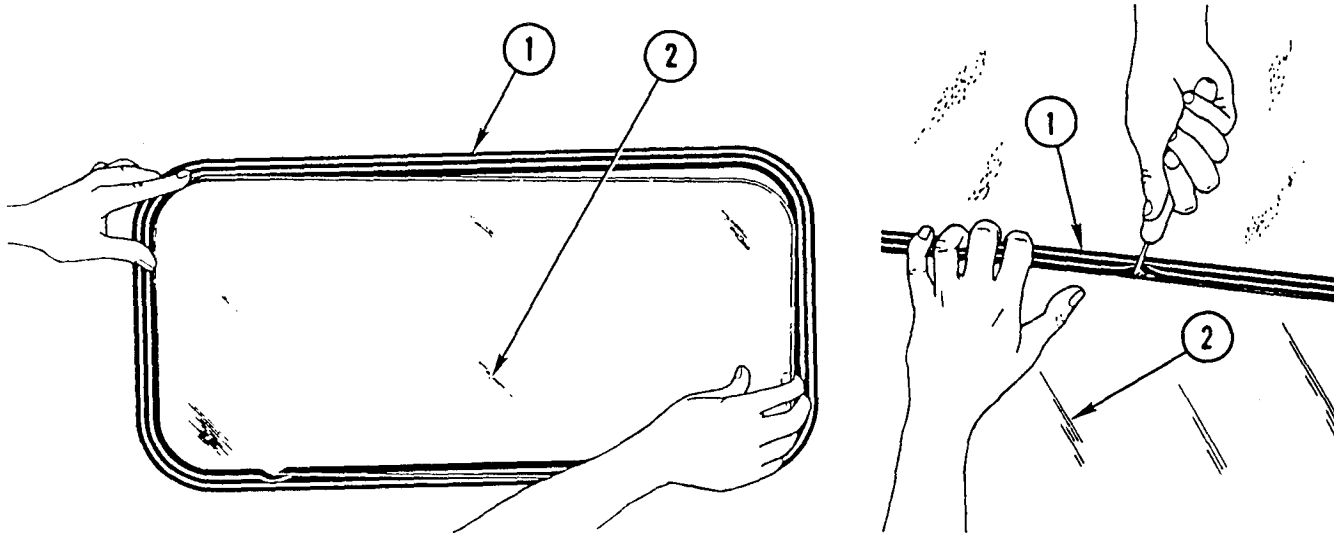

WARNING

Wear protective gloves when handling glass, Failure to do so could result in injury to personnel.

CAUTION

- When handling rear window glass, be careful not to nick or splinter edges. Chipped edges could cause cracking later.
- Do not use sealant around rear window glass. Sealing compounds are not needed and, if applied unevenly, can cause leaks resulting in water damage.

NOTE

If installing rear window glass only, perform steps 1 thru 4. If installing rear window glass and seal, perform steps 5 thru 7.

1. LUBRICATE REAR WINDOW CHANNEL OF RUBBER EXTRUSION (1) WITH SOAP AND WATER SOLUTION.
2. SLIDE REAR WINDOW GLASS (2) INTO WINDOW CHANNEL OF RUBBER EXTRUSION (1) AS FAR AS IT WILL GO WITHOUT FORCING.
3. USING WINDSHIELD PICK, ALTERNATE BETWEEN TOP AND BOTTOM OF REAR WINDOW GLASS (2) AND WORK RUBBER EXTRUSION (1) OVER EDGE OF REAR WINDOW GLASS (2).

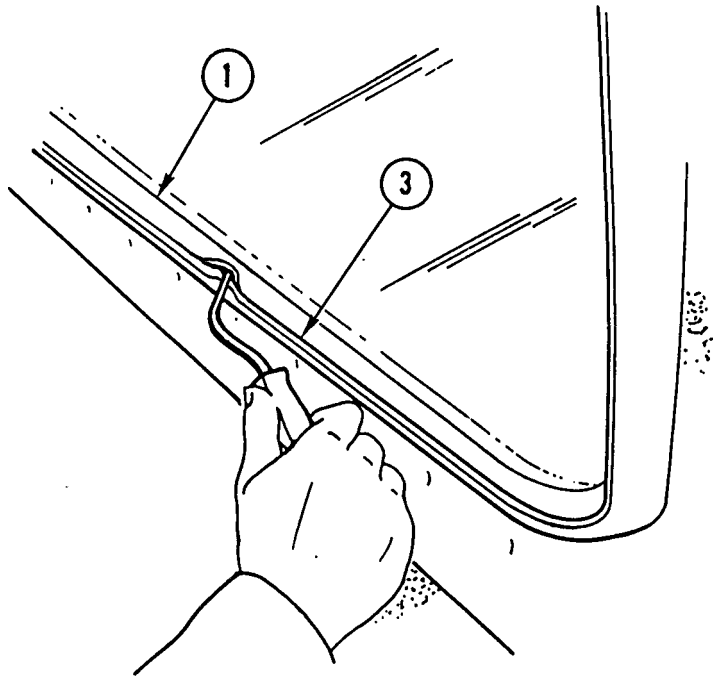

4. USING WINDSHIELD PICK, INSTALL LOCKING STRIP (3) IN RUBBER EXTRUSION (1).

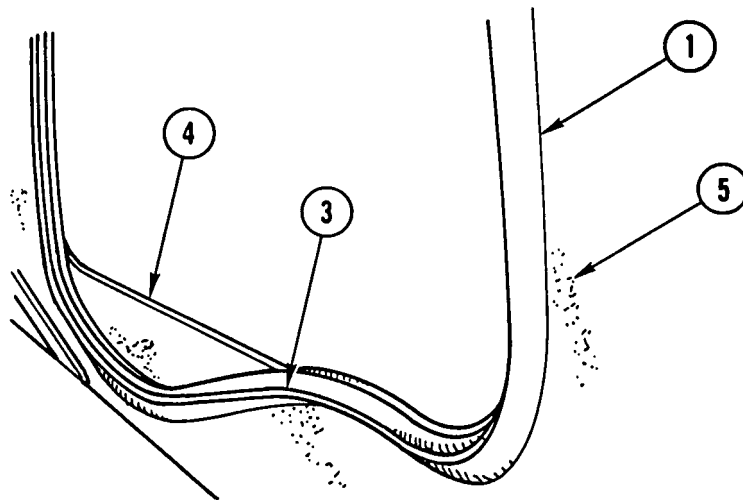

5. WITH LOCKING STRIP (3) FACING OUT, INSTALL RUBBER EXTRUSION (1) OVER MOUNTING FLANGE (4) OF CAB (5).

REAR WINDOW REPLACEMENT (CONT)

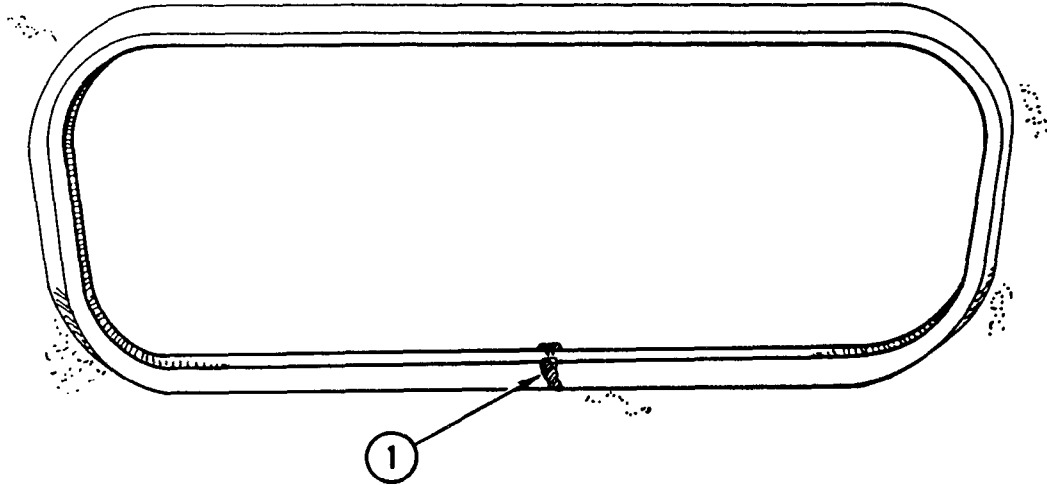

6. INSTALL SEALING COMPOUND ONLY AT POINT WHERE BOTH ENDS OF RUBBER EXTRUSION (1) MEET.
7. PERFORM STEPS 1 THRU 4.

CAB DOOR REPLACEMENT

This task covers: a. Removal b. Cleaning c. Inspection d. Installation

Tools and Special Equipment:

Tool Kit, SC 5180-90-CL-N05

Materials/Parts:

Tape, Foam P/N 4800050208

Personnel Required: (2)

References:

TM 9-2320-363-20

Equipment Condition:

Reference

Condition Description

TM 9-2320-363-20

Rear View Mirror
Removed

General Safety Instructions:

WARNING

Due to size of door and angle for removal or installation, use minimum of two personnel to remove or install door, Failure to do so could result in injury to personnel.

CAB DOOR REPLACEMENT (CONT)

REMOVAL

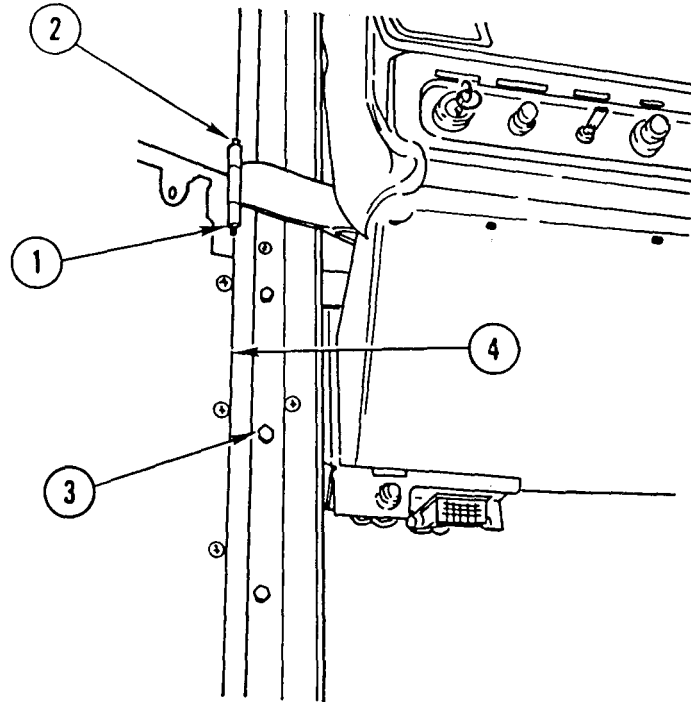

NOTE

Procedure is the same for both doors,

1. REMOVE CAP NUT (1) AND SOCKET HEAD SCREW (2).

WARNING

Due to size of door and angle for removal, use minimum of two personnel to remove door. Failure to do so could result in injury to personnel.

2. REMOVE EIGHT CAPSCREWS (3) AND DOOR (4).

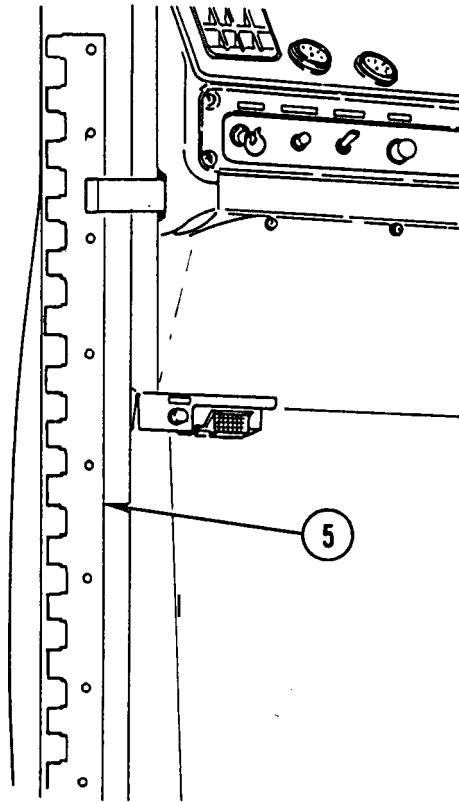

3. REMOVE AND DISCARD FOAM TAPE (5).

CLEANING

Use general cleaning methods to clean all parts (page 2-30).

INSPECTION

1. INSPECT DOOR SEALS AND WINDOW CHANNELS FOR DAMAGE.
2. INSPECT DOOR LOCKS, REGULATORS, AND RELEASE HANDLES FOR PROPER OPERATION. IF DAMAGED, REFER TO DOOR REPAIR (PAGE 22-28).

CAB DOOR REPLACEMENT (CONT)

INSTALLATION

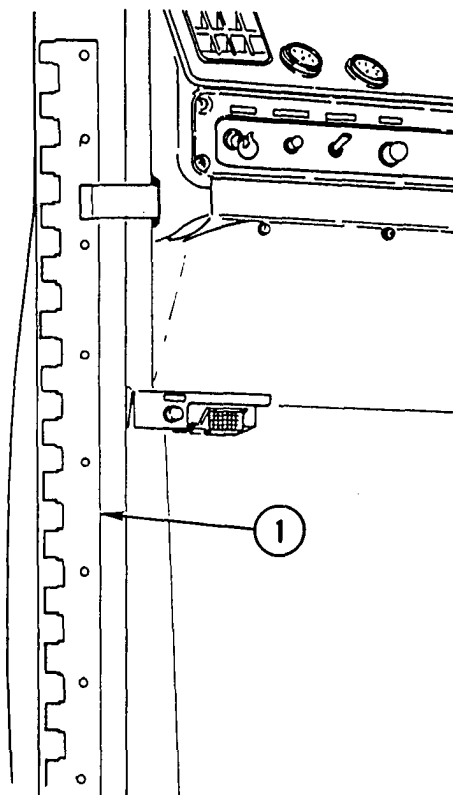

CAUTION

Make sure all old foam tape has been removed. Failure to do so could cause water leakage and damage.

NOTE

Procedure is the same for both doors.

1. INSTALL NEW FOAM TAPE (1) AND, USING SHARP IMPLEMENT, CUT HOLES FOR CAPSCREW INSTALLATION.

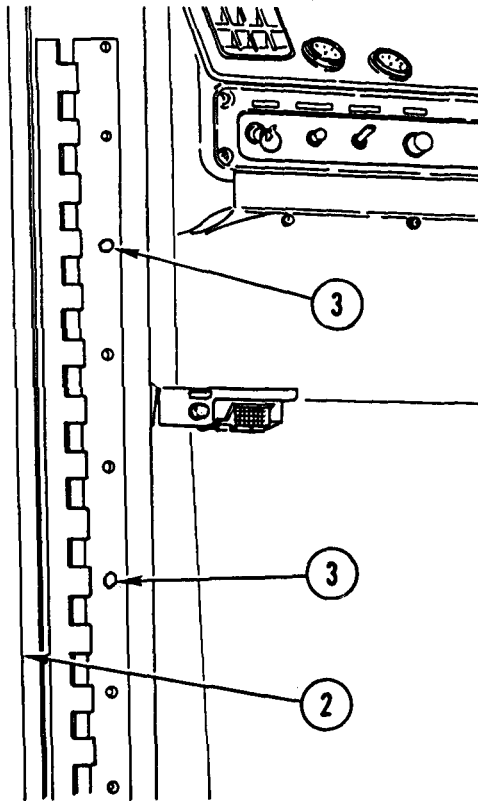

WARNING

Due to size of door and angle for installation, use minimum of two personnel to install door. Failure to do so could result in injury to personnel.

2. INSTALL DOOR (2).
3. INSTALL TWO CAPSCREWS (3) HAND-TIGHT IN LOCATIONS INDICATED.
4. PERFORM DOOR ADJUSTMENT IN ACCORDANCE WITH TM 9-2320-363-20.
5. INSTALL REMAINING SIX CAPSCREWS (3).

CAB DOOR REPLACEMENT (CONT)

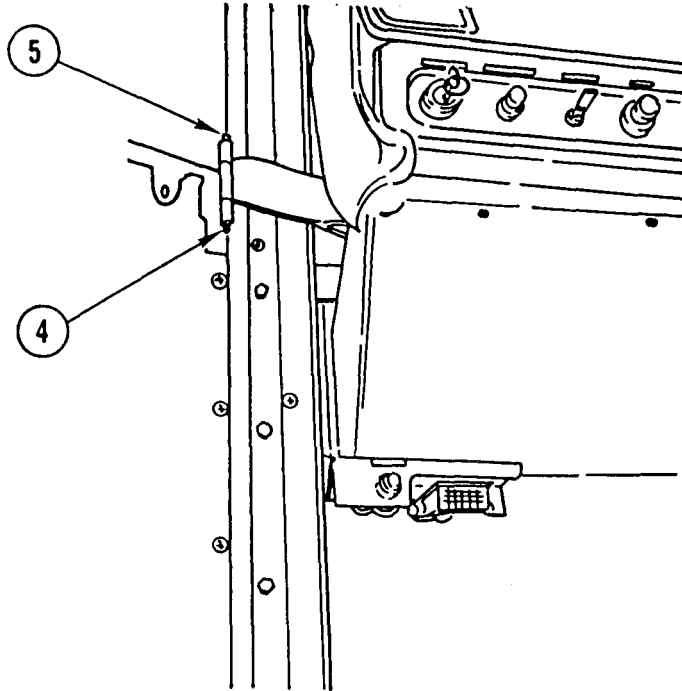

6. INSTALL CAP NUT (4) AND SOCKET HEAD SCREW (5).

NOTE

Follow-on Maintenance.
Install rear view mirror (TM 9-2320-363-20).

CHAPTER 11
WINCH MAINTENANCE

OVERVIEW

This chapter illustrates and describes procedures for maintenance of the winch and related parts. A list of tasks contained in this chapter is shown below.

	Page
Hydraulic Pump Replacement (M916A1 and M916A2)	11-2
Hydraulic Winch Replacement (M916A1 and M916A2)	11-9
Hydraulic Motor Replacement (M916A1 and M916A2)	11-15
Counterbalance Valve Replacement and Repair (M916A1 and M916A2)	11-20
Speed Control Valve Replacement (M916A1 and M916A2)	11-26
Direction Control Valve Replacement (M916A1 and M916A2)	11-30
Hydraulic Winch Frame Replacement (M916A1 and M916A2)	11-34
Winch Hydraulic Oil Filter Adapter Replacement (M916A1 and M916A2)	11-39
Power Take-Off (PTO) Replacement (All Except M915A2)	11-42

HYDRAULIC PUMP REPLACEMENT

This task covers: a. Removal b. Cleaning c. Inspection d. Repair e. Installation

INITIAL SETUP

Applicable Configuration:

M916A1 and M916A2

Tools and Special Equipment:

Shop Equipment, SC 4910-95-CL-A31
Tool Kit, SC 5180-90-CL-N05

Materials/Parts:

Packing (4)	P/N 58864 9961
Nut, Lock (2)	
Washer, Lock (4)	
Washer, Lock (16)	P/N 1123
Compound, Pipe Sealing	Appendix B, Item 15

Personnel Required: (2)

References:

TM 9-2320-363-20

Equipment Condition:

Reference	Condition Description
TM 9-2320-363-20	Winch Hydraulic Oil Tank Drained
TM 9-2320-363-20	Transmission Tunnel Access Cover Removed

General Safety Instructions:

WARNING

- Adhesives, solvents, and sealing compounds can burn easily, can give off harmful vapors, and are harmful to skin and clothing. To avoid injury or death, keep away from open fire and use in well-ventilated area. If adhesive, solvent, or sealing compound gets on skin or clothing, wash immediately with soap and water.
- Hydraulic pump is heavy. Use extreme caution during removal to prevent possible injury to personnel or damage to equipment.

REMOVAL

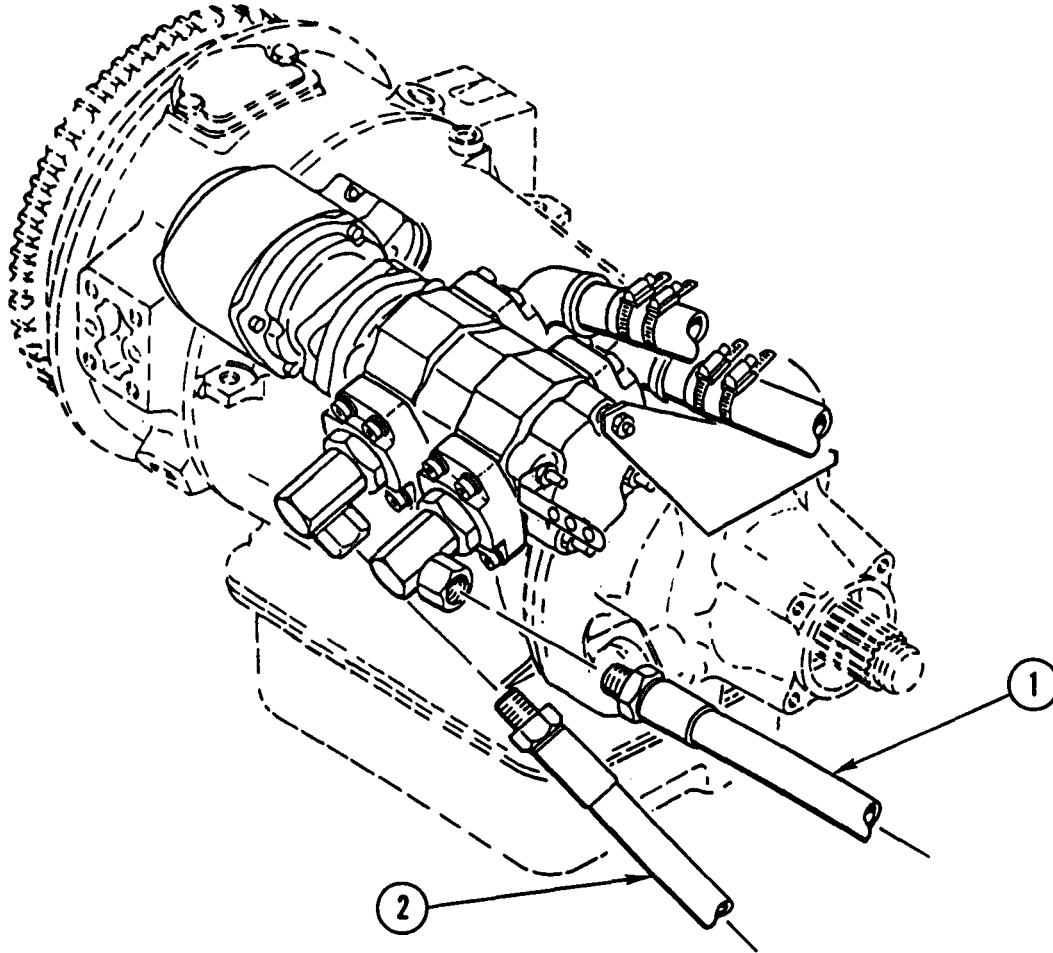

1. DISCONNECT TWO HOSE ASSEMBLIES (1 AND 2).

HYDRAULIC PUMP REPLACEMENT (CONT)

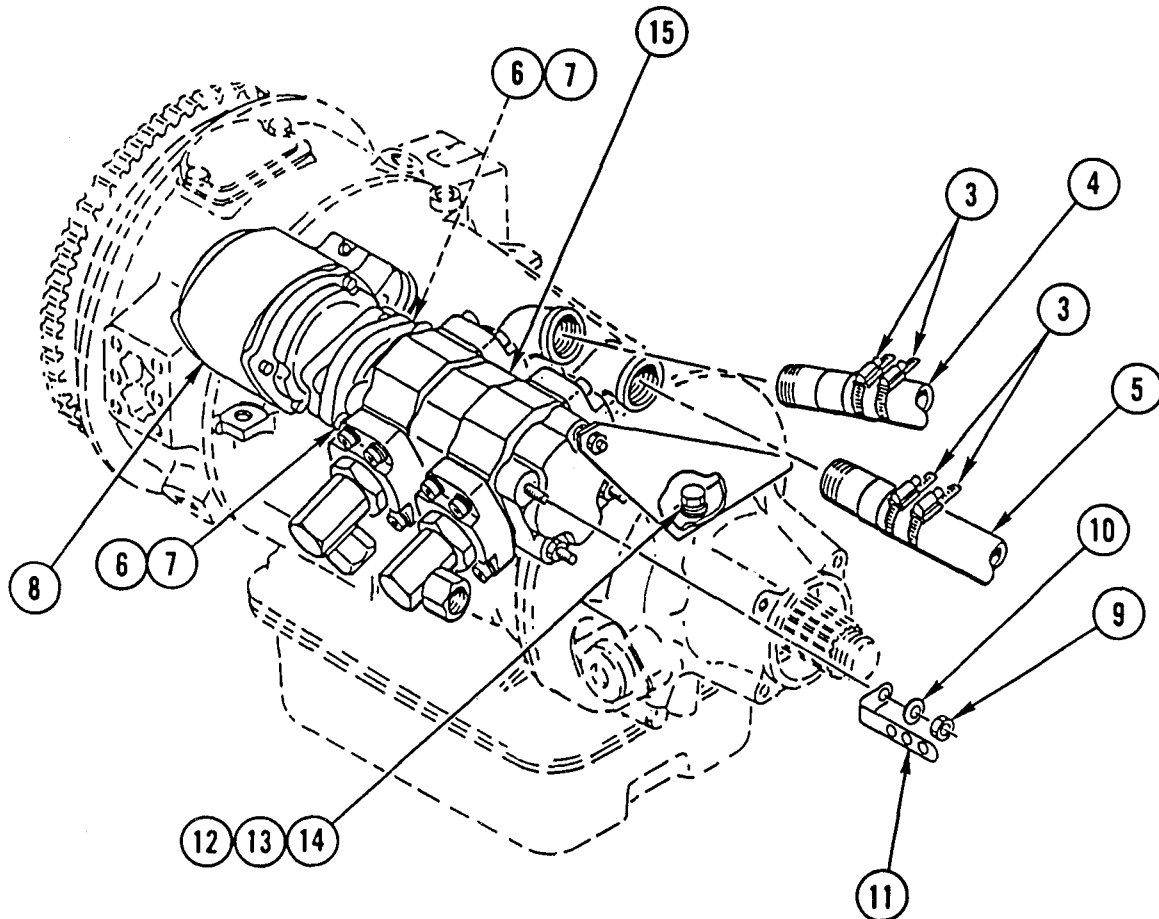

2. LOOSEN FOUR CLAMPS (3) AND DISCONNECT TWO HOSE AND ADAPTER ASSEMBLIES (4 AND 5).
3. REMOVE TWO BOLTS (6) AND TWO LOCK WASHERS (7) FROM PTO (8). DISCARD LOCK WASHERS.
4. REMOVE LOCK NUT (9), WASHER (10), AND BRACKET(11). DISCARD LOCK NUT.

WARNING
Hydraulic pump is heavy. Use extreme caution during removal to prevent possible injury to personnel or damage to equipment.

5. REMOVE TWO BOLTS (12), TWO WASHERS (13), TWO LOCK WASHERS (14), AND HYDRAULIC PUMP (15). DISCARD LOCK WASHERS.

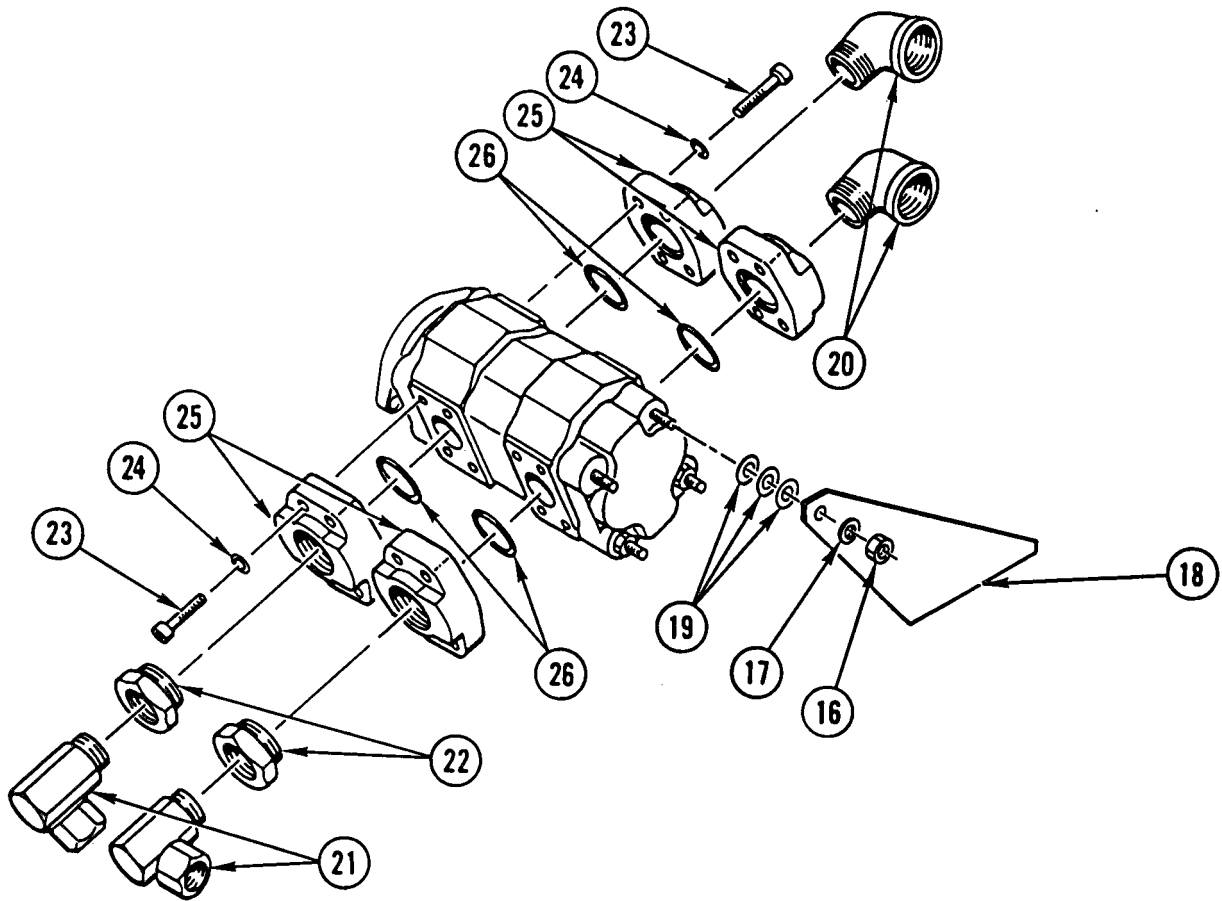

6. REMOVE LOCK NUT (16), WASHER (17), BRACKET (18), AND THREE SPACERS (19). DISCARD LOCK NUT.
7. REMOVE TWO ELBOWS (20).
8. REMOVE TWO ELBOWS (21) AND TWO ADAPTERS (22).
9. REMOVE 16 SOCKET HEAD SCREWS (23), 16 LOCK WASHERS (24), 4 ADAPTERS (25), AND 4 PACKINGS (26). DISCARD PACKINGS AND LOCK WASHERS.

CLEANING

Use general cleaning methods to clean all parts (page 2-30).

INSPECTION

Inspect all parts for wear or damage.

REPAIR

Use general repair methods to repair damaged parts (page 2-33).

HYDRAULIC PUMP REPLACEMENT (CONT)

INSTALLATION

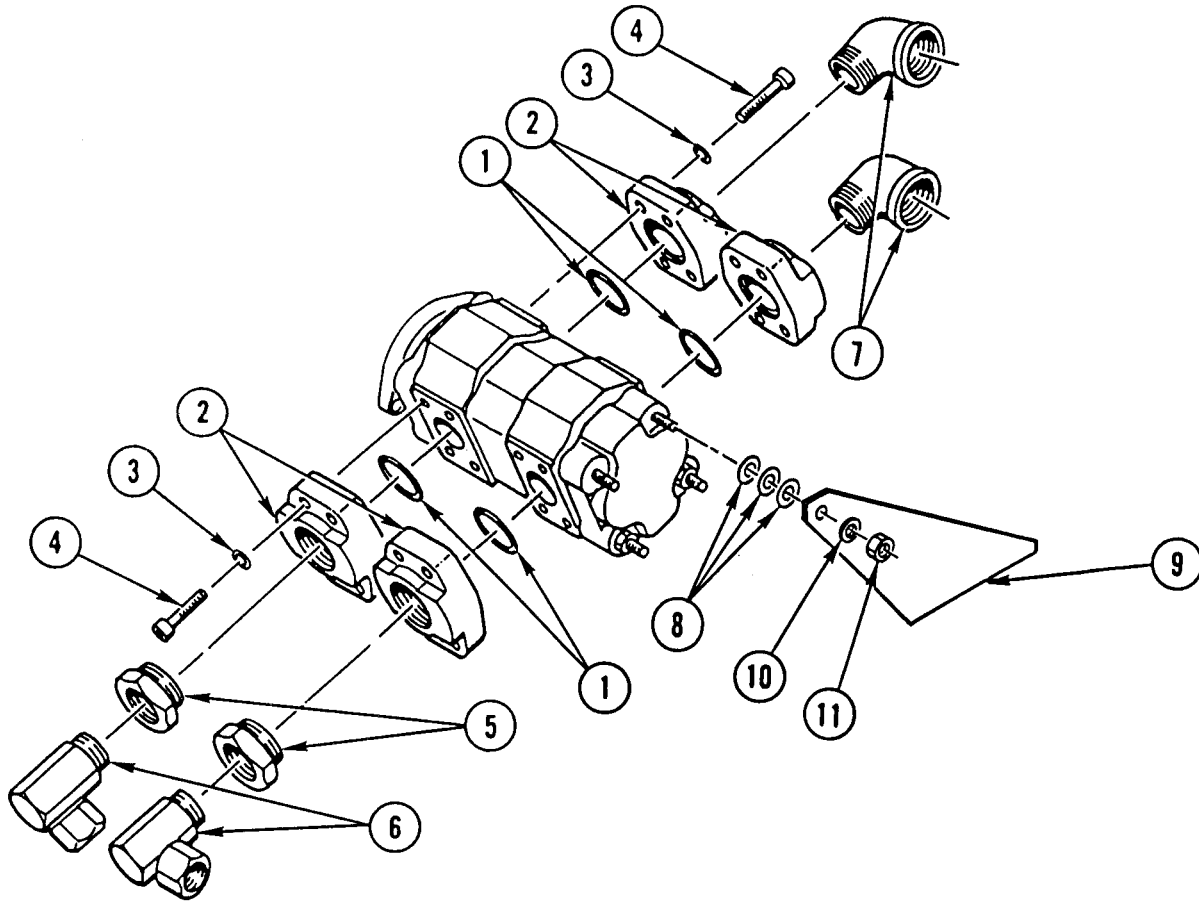

1. INSTALL 4 NEW PACKINGS (1), 4 ADAPTERS (2), 16 NEW LOCK WASHERS (3), AND 16 SOCKET HEAD SCREWS (4).
2. INSTALL TWO ADAPTERS (5) AND TWO ELBOWS (6).

WARNING

Adhesives, solvents, and sealing compounds can burn easily, can give off harmful vapors, and are harmful to skin and clothing. To avoid injury or death, keep away from open fire and use in well-ventilated area. If adhesive, solvent, or sealing compound gets on skin or clothing, wash immediately with soap and water.

3. COAT THREADS OF TWO ELBOWS (7) AND TWO ADAPTERS (8) WITH PIPE SEALING COMPOUND.

4. INSTALL TWO ELBOWS (7).
5. INSTALL THREE SPACERS (8), BRACKET (9), WASHER (10), AND NEW LOCK NUT (11).

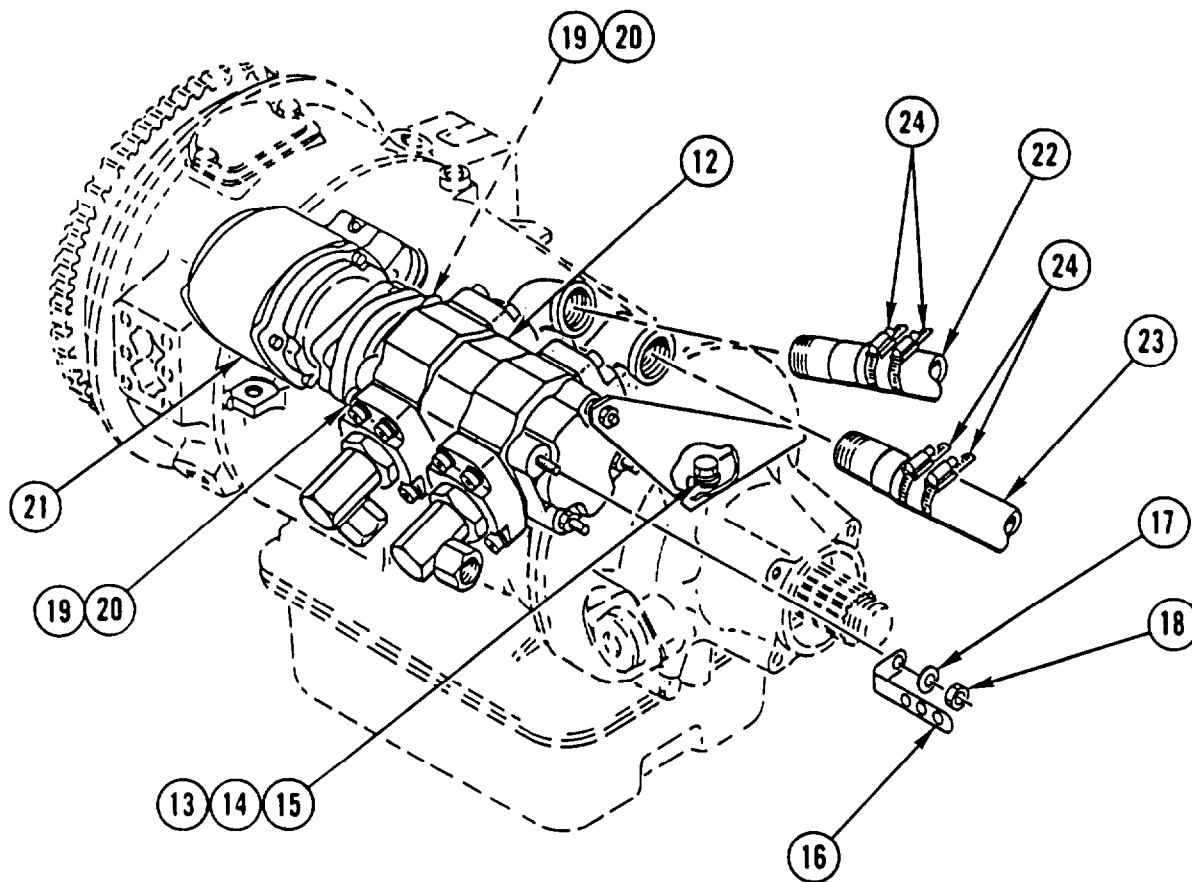

6. INSTALL HYDRAULIC PUMP (12), TWO NEW LOCK WASHERS (13), TWO WASHERS (14), AND TWO BOLTS (15).
7. INSTALL BRACKET (16), WASHER (17), AND NEW LOCK NUT (18).
8. INSTALL TWO NEW LOCK WASHERS (19) AND TWO BOLTS (20) IN PTO (21).
9. CONNECT TWO HOSE AND ADAPTER ASSEMBLIES (22 AND 23) AND TIGHTEN FOUR CLAMPS (24).

HYDRAULIC PUMP REPLACEMENT (CONT)

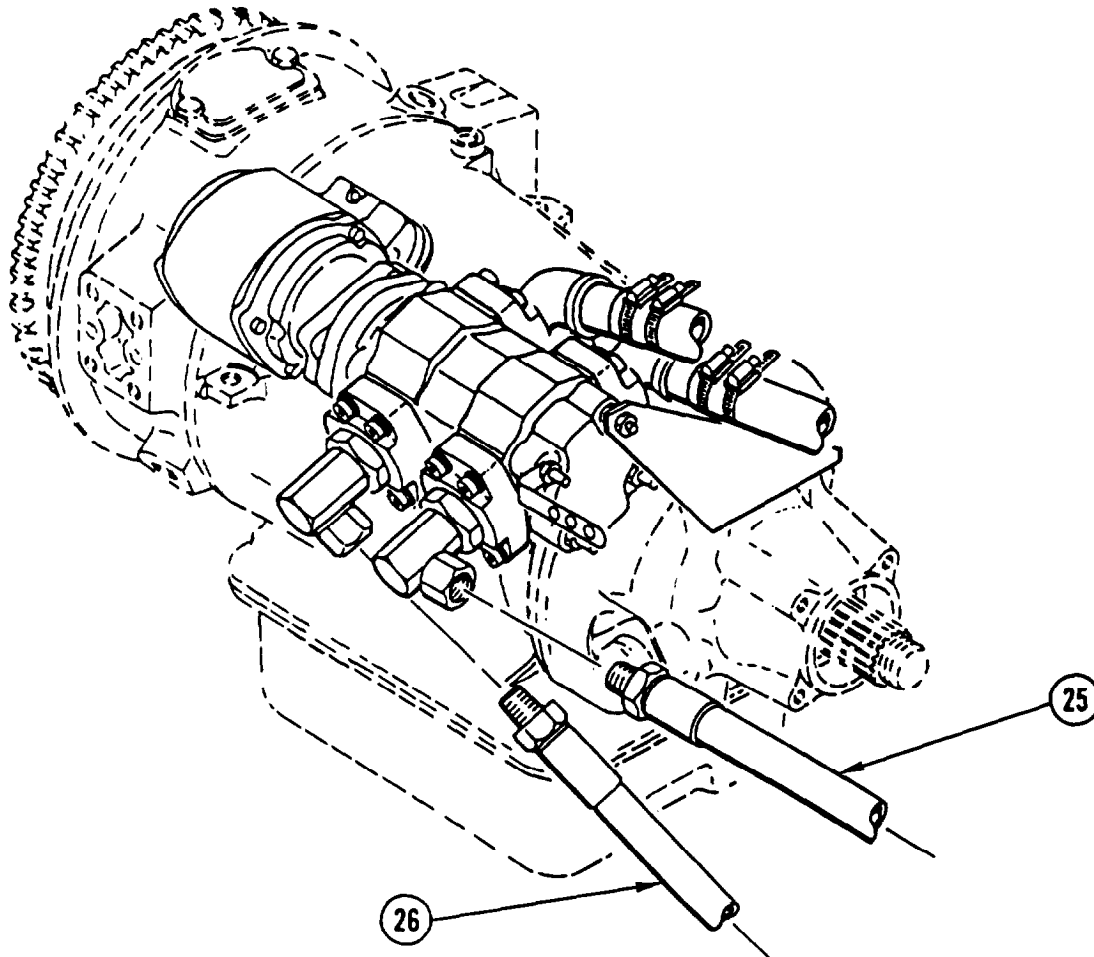

10. CONNECT TWO HOSE ASSEMBLIES (25 AND 26).

NOTE

Follow-on Maintenance:

Fill winch hydraulic oil tank (TM 9-2320-363-20).

Install transmission tunnel access cover (TM 9-2320-363-20).

HYDRAULIC WINCH REPLACEMENT

This task covers: a. Removal b. Cleaning c. Inspection d. Installation

INITIAL SETUP

Applicable Configuration:

M916A1 and M916A2

Tools and Special Equipment:

Tool Kit, SC 5180-90-CL-N05

Materials/Parts:

Washer, Lock (4) P/N 1295

Washer, Lock (14) P/N 1695

References:

TM 9-2320-363-20

Equipment Condition:

Reference	Condition	Description
TM 9-2320-363-20	Winch Wire Rope Removed	
Page 11-15	Hydraulic Motor Removed	
TM 9-2320-363-20	Hosetenna Removed	

General Safety Instructions:

WARNING

Winch weighs 2,460 lb (1116 kg). Support winch with suitable hoist during removal or installation to prevent possible injury to personnel.

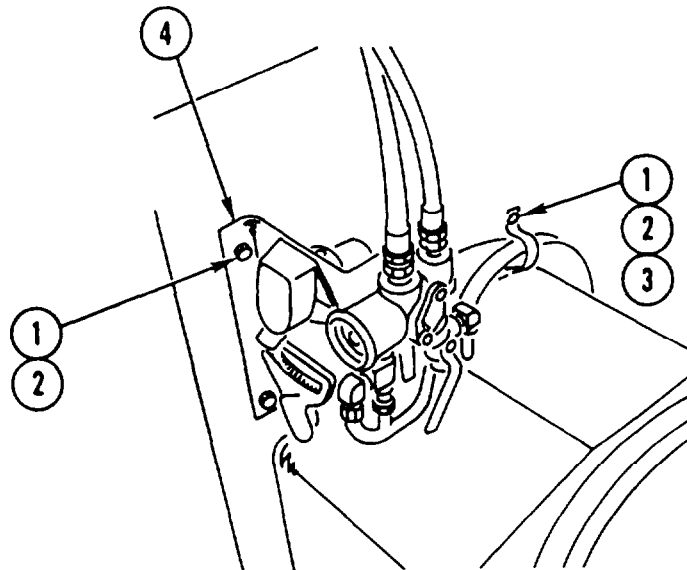

1. REMOVE FOUR SCREWS (1), FOUR WASHERS (2), AND CLAMP (3) AND SET BRACKET ASSEMBLY (4) ASIDE.

HYDRAULIC WINCH REPLACEMENT (CONT)

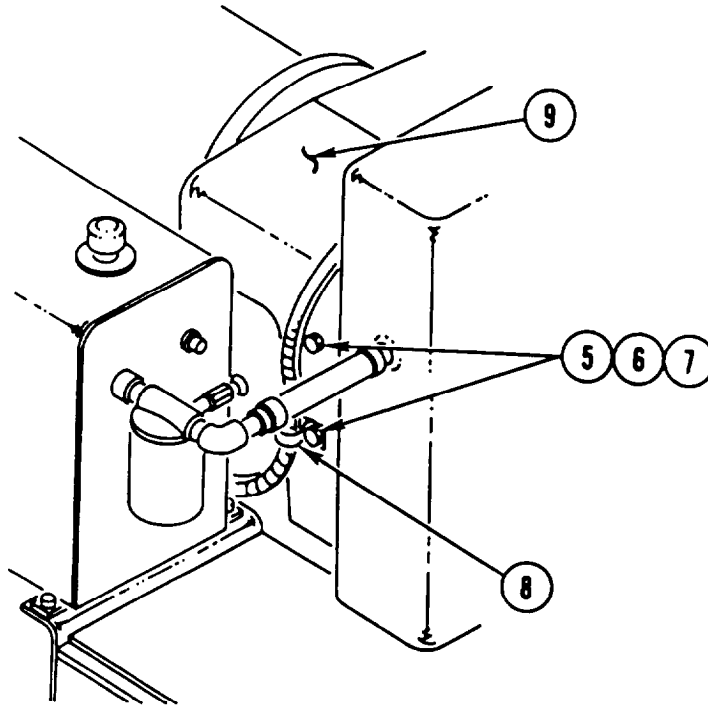

2. REMOVE FOUR NUTS (5), FOUR LOCK WASHERS (6), FOUR SCREWS (7), CLAMP (8), AND COVER (9). DISCARD LOCK WASHERS.

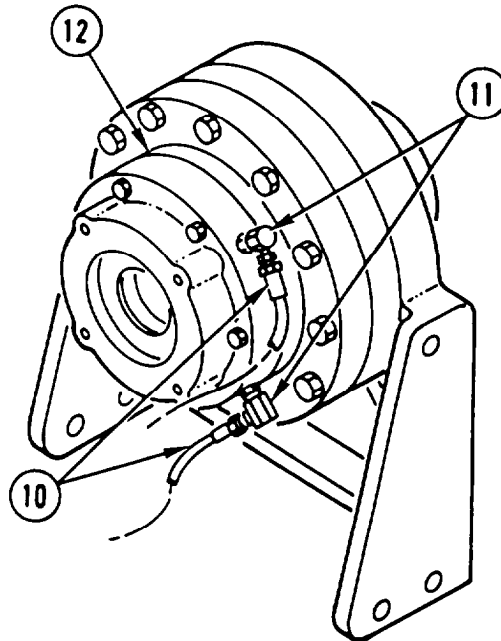

3. REMOVE TWO HOSES (10) AND TWO SWIVELS (11) FROM BRAKE HOUSING (12).

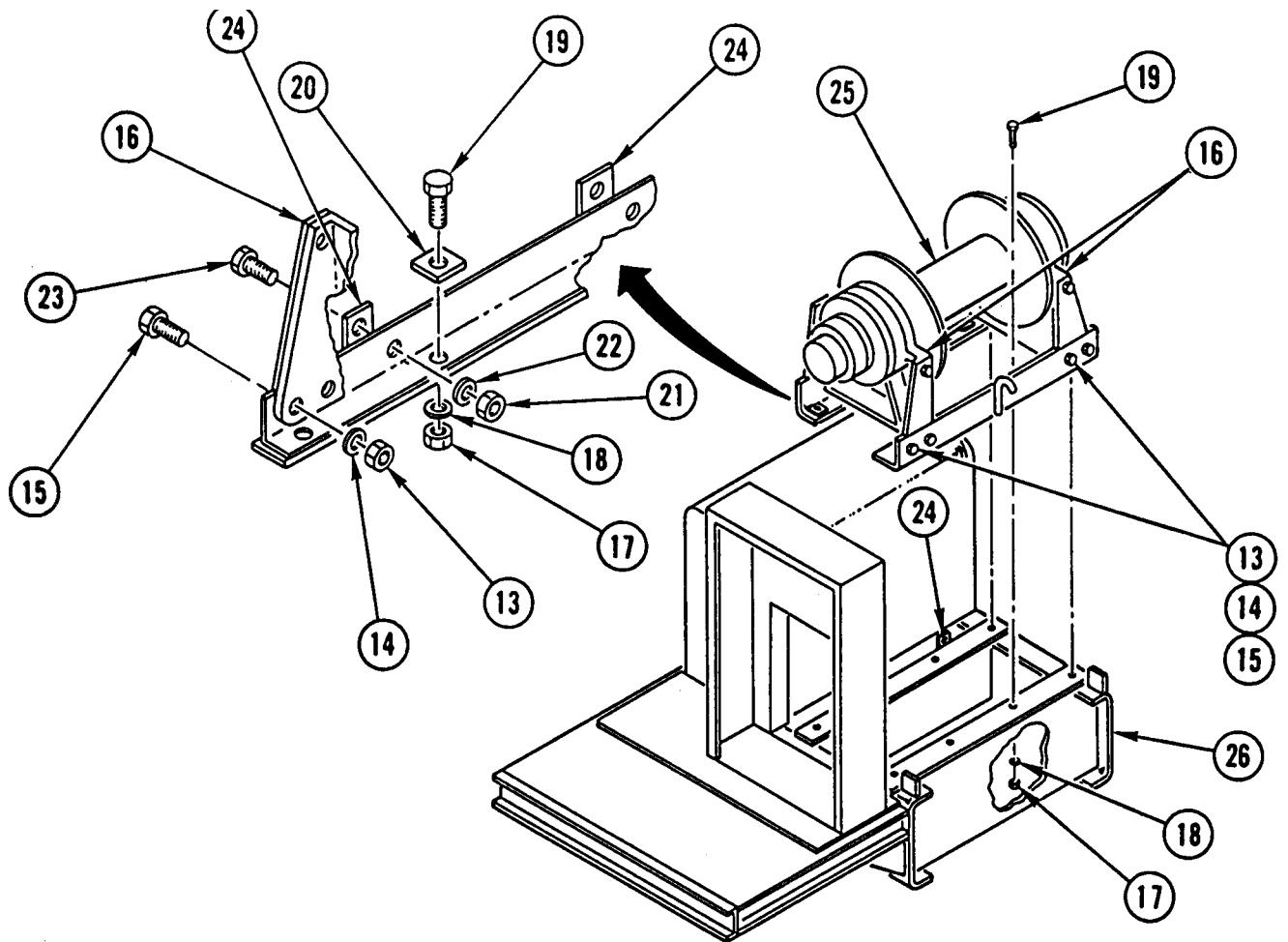

4. REMOVE FOUR NUTS (13), FOUR LOCK WASHERS (14), AND FOUR SCREWS (15) FROM END SUPPORT (16). DISCARD LOCK WASHERS.
5. REMOVE EIGHT NUTS (17), EIGHT LOCK WASHERS (18), EIGHT SCREWS (19), AND FOUR SPACERS (20). DISCARD LOCK WASHERS.
6. REMOVE TWO NUTS (21), TWO LOCK WASHERS (22), AND TWO SCREWS (23) FROM WELD STRAPS (24). DISCARD LOCK WASHERS.

WARNING

Winch weighs 2,460 lb (1116 kg). Support winch with suitable hoist during removal to prevent possible injury to personnel.

7. USING SUITABLE HOIST, REMOVE WINCH (25) FROM FRAME (26).

CLEANING

Use general cleaning methods to clean all parts (page 2-30).

HYDRAULIC WINCH REPLACEMENT (CONT)

INSPECTION

Inspect all parts for wear or damage.

INSTALLATION

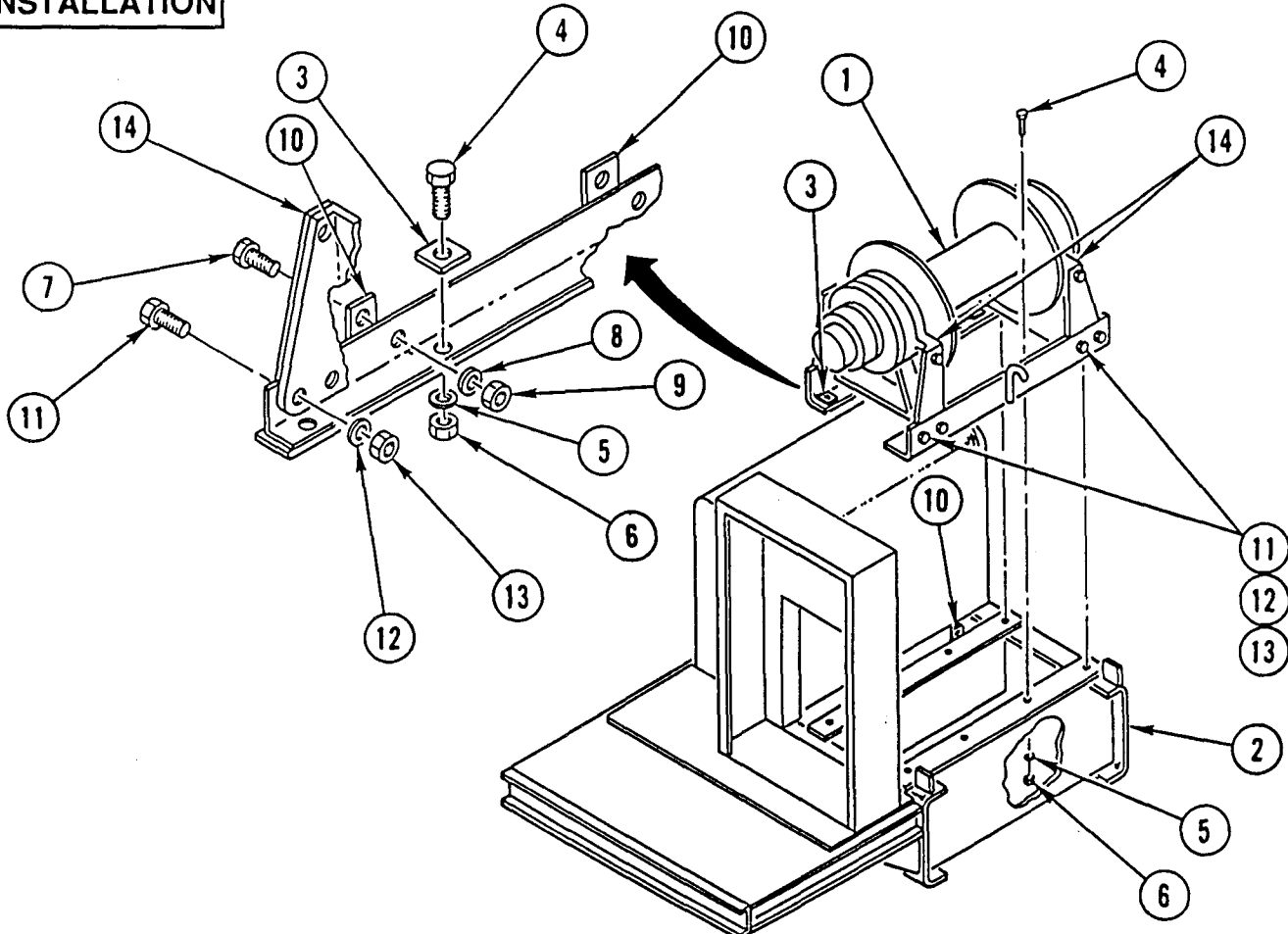

WARNING

Winch weighs 2,460 lb (1116 kg). Support winch with suitable hoist during installation to prevent possible injury to personnel.

CAUTION

Install spacers on side closest to hydraulic reservoir. Failure to do so could result in damage to equipment.

1. USING SUITABLE HOIST, PLACE WINCH (1) ON FRAME (2) AND INSTALL FOUR SPACERS (3), EIGHT SCREWS (4), EIGHT NEW LOCK WASHERS (5), AND EIGHT NUTS (6).

2. INSTALL TWO SCREWS (7), TWO NEW LOCK WASHERS (8), AND TWO NUTS (9) IN WELD STRAPS (10).
3. INSTALL FOUR SCREWS (11), FOUR NEW LOCK WASHERS (12), AND FOUR NUTS (13) IN END SUPPORT (14).

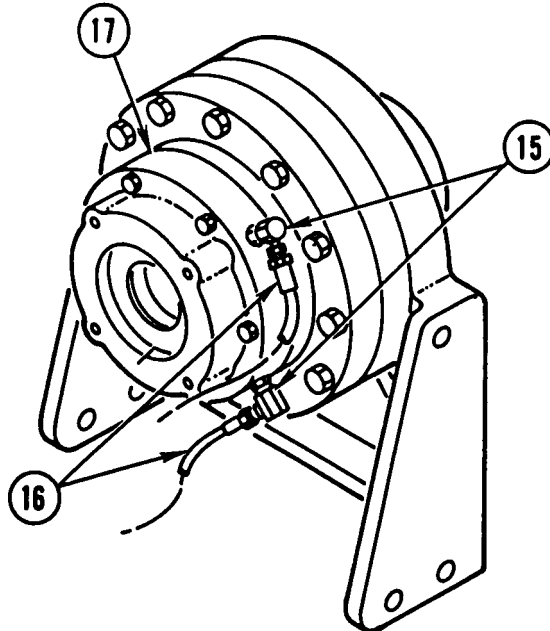

4. INSTALL TWO SWIVELS (15) AND TWO HOSES (16) IN BRAKE HOUSING (17).

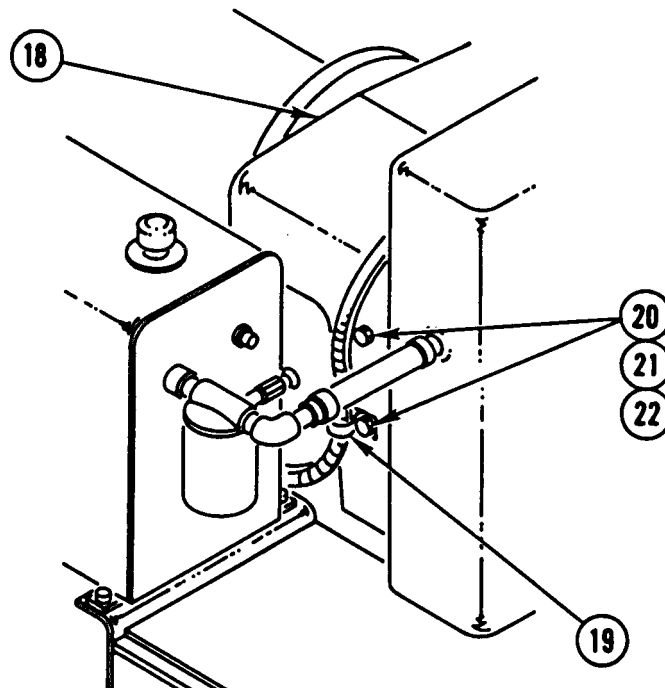

5. INSTALL COVER (18), CLAMP (19), FOUR SCREWS (20), FOUR NEW LOCK WASHERS (21), AND FOUR NUTS (22).

HYDRAULIC WINCH REPLACEMENT (CONT)

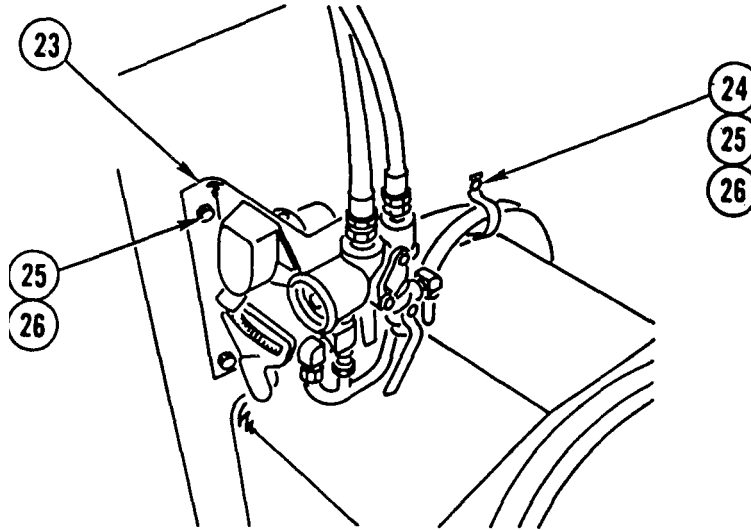

6. INSTALL BRACKET ASSEMBLY (23), CLAMP (24), FOUR WASHERS (25), AND FOUR SCREWS (26).

NOTE

Follow-on Maintenance:

- Install hosenenna (TM 9-2320-363-20).
- Install hydraulic motor (page 11-15).
- Install winch wire rope (TM 9-2320-363-20).

HYDRAULIC MOTOR REPLACEMENT

This task covers: a. Removal b. Cleaning c. Inspection d. Installation

INITIAL SETUP

Applicable Configuration:

M916A1 and M916A2

Tools and Special Equipment:

Shop Equipment, SC 4910-95-CL-A31

Tool Kit, SC 5180-90-CL-N05

Materials/Parts:

Packing (2)	P/N 58864 9962
Gasket	P/N 58864 1162
Washer, Lock (6)	P/N 1295
Washer, Lock (4)	P/N 1495
Washer, Lock (4)	P/N 1144
Compound, Pipe Sealing	Appendix B, Item 15

References:

TM 9-2320-363-20

Equipment Condition:

Reference	Condition Description
TM 9-2320-363-20	Winch Hydraulic Oil Tank Drained

General Safety Instructions:

WARNING

Adhesives, solvents, and sealing compounds can burn easily, can give off harmful vapors, and are harmful to skin and clothing. To avoid injury or death, keep away from open fire and use in well-ventilated area. If adhesive, solvent, or sealing compound gets on skin or clothing, wash immediately with soap and water.

HYDRAULIC MOTOR REPLACEMENT (CONT)

REMOVAL

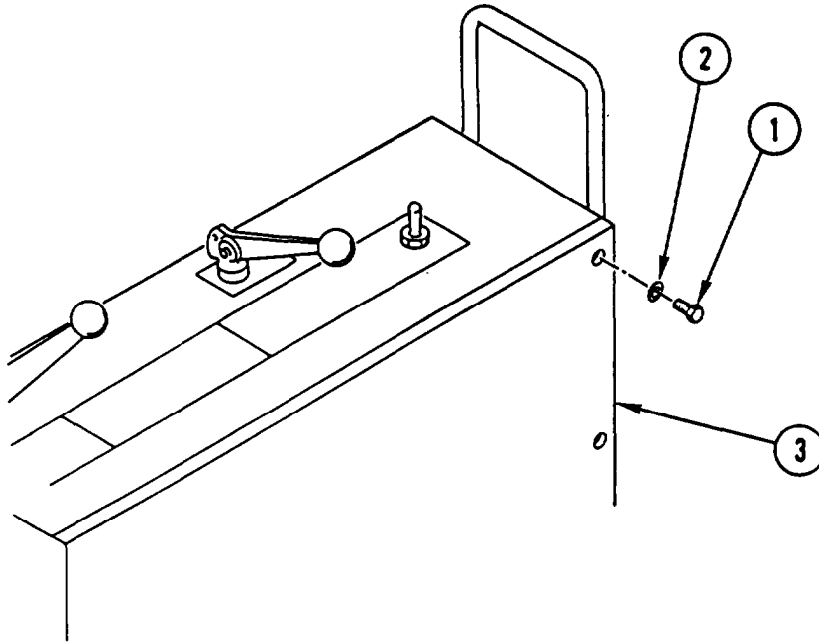

1. REMOVE SIX CAPSCREWS (1), SIX LOCK WASHERS (2), AND COVER (3). DISCARD LOCK WASHERS.

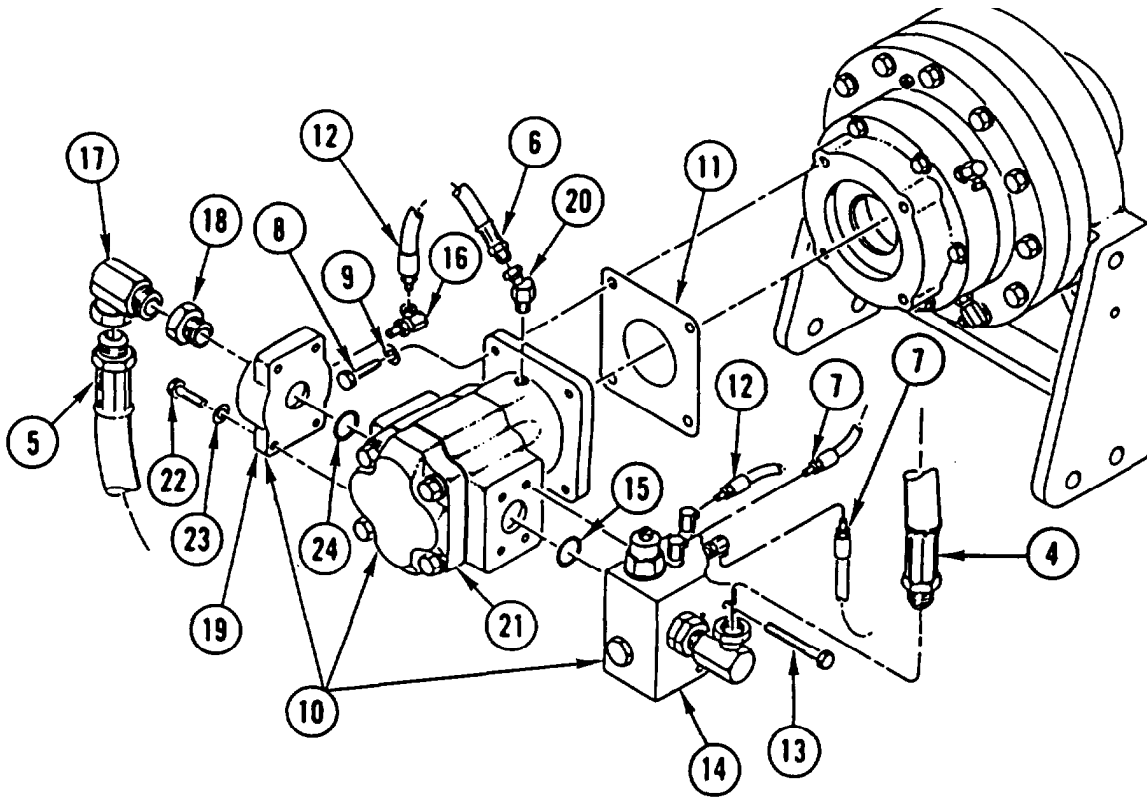

2. DISCONNECT AND SET ASIDE HOSE (4), HOSE (5), HOSE (6), AND TWO HOSES (7).
3. REMOVE FOUR SCREWS (8), FOUR LOCK WASHERS (9), MOTOR ASSEMBLY (10), AND GASKET (11). DISCARD GASKET AND LOCK WASHERS.
4. REMOVE HOSE (12), FOUR SCREWS (13), COUNTERBALANCE VALVE (14), AND PACKING (15). DISCARD PACKING.
5. REMOVE SWIVEL (16), SWIVEL (17), AND BUSHING (18) FROM FLANGE (19).
6. REMOVE SWIVEL (20) FROM MOTOR (21).
7. REMOVE FOUR SCREWS (22), FOUR LOCK WASHERS (23), FLANGE (19), AND PACKING (24) FROM MOTOR (21). DISCARD PACKING AND LOCK WASHERS.

CLEANING

Use general cleaning methods to clean all parts (page 2-30).

INSPECTION

Inspect all parts for wear or damage.

HYDRAULIC MOTOR REPLACEMENT (CONT)

INSTALLATION

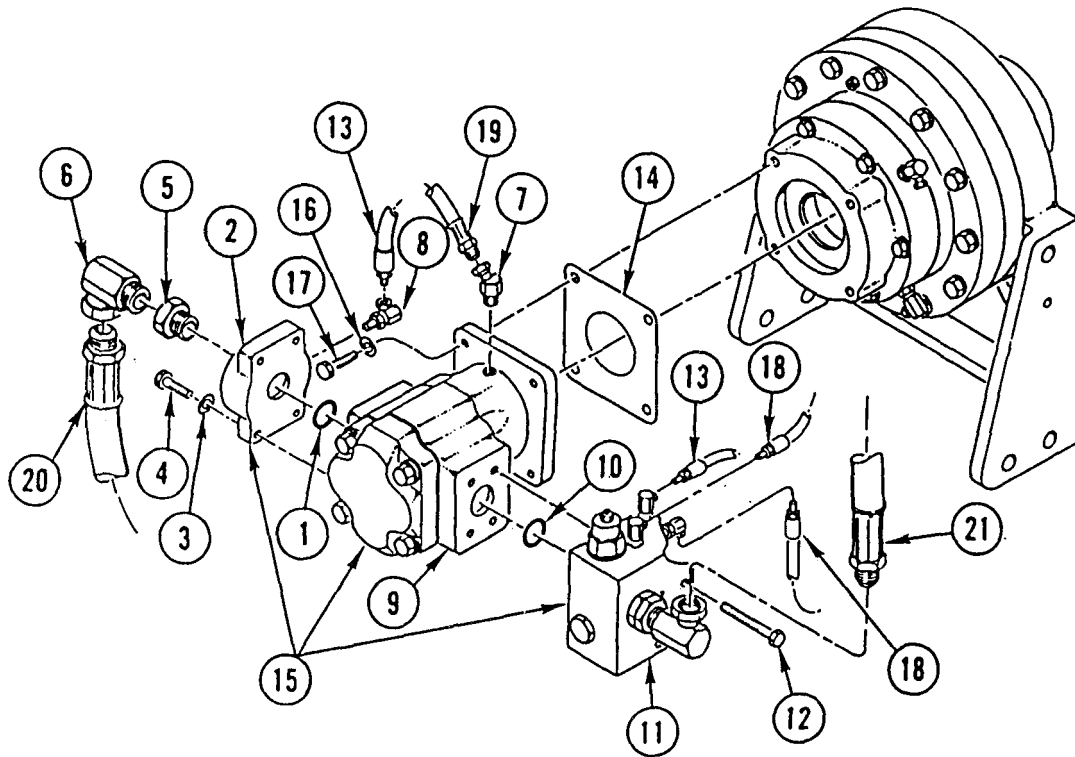

1. INSTALL NEW PACKING (1), FLANGE (2), FOUR NEW LOCK WASHERS (3), AND FOUR SCREWS (4).

WARNING

Adhesives, solvents, and sealing compounds can burn easily, can give off harmful vapors, and are harmful to skin and clothing. To avoid injury or death, keep away from open fire and use in well-ventilated area. If adhesive, solvent, or sealing compound gets on skin or clothing, wash immediately with soap and water.

2. COAT THREADS OF BUSHING (5) AND SWIVEL (6) WITH PIPE SEALING COMPOUND AND INSTALL BUSHING (5) AND SWIVEL (6) IN FLANGE (2).
3. COAT THREADS OF TWO SWIVELS (7 AND 8) WITH PIPE SEALING COMPOUND. INSTALL SWIVEL (7) ON MOTOR (9) AND INSTALL SWIVEL (8) ON FLANGE (2).
4. INSTALL NEW PACKING (10), COUNTERBALANCE VALVE (11), FOUR SCREWS (12), AND HOSE (13).
5. INSTALL NEW GASKET (14), MOTOR ASSEMBLY (15), FOUR NEW LOCK WASHERS (16), AND FOUR SCREWS (17).

- CONNECT TWO HOSES (18), HOSE (19), HOSE (20), AND HOSE (21).

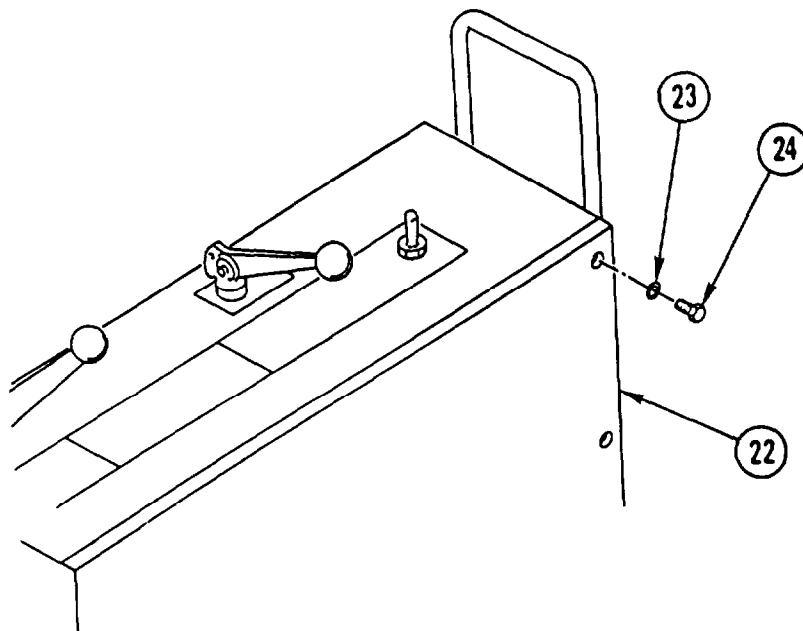

- INSTALL COVER (22), SIX NEW LOCK WASHERS (23), AND SIX CAPSCREWS (24).

NOTE

Follow-on Maintenance:

Fill winch hydraulic oil tank (TM 9-2320-363-20).

COUNTERBALANCE VALVE REPLACEMENT AND REPAIR

This task covers: a. Removal b. Disassembly c. Cleaning d. Inspection e. Repair f. Assembly
a. Installation

INITIAL SETUP

Applicable Configuration:

M916A1 and M916A2

Tools and Special Equipment:

Shop Equipment, SC 4910-95-CL-A31

Tool Kit, SC 5180-90-CL-N05

Materials/Parts:

Kit, Parts P/N 58864 9863

Packing P/N 58864 9962

Washer, Lock (6) P/N 1295

Materials/Parts (Cont):

Packing (3) P/N 76511

Packing P/N 2507-16-16

Packing P/N SAE 11-20-16

References:

TM 9-2320-363-20

Equipment Condition:

Reference	Condition	Description
TM 9-2320-363-20	Winch Hydraulic Oil Tank Drained	

REMOVAL

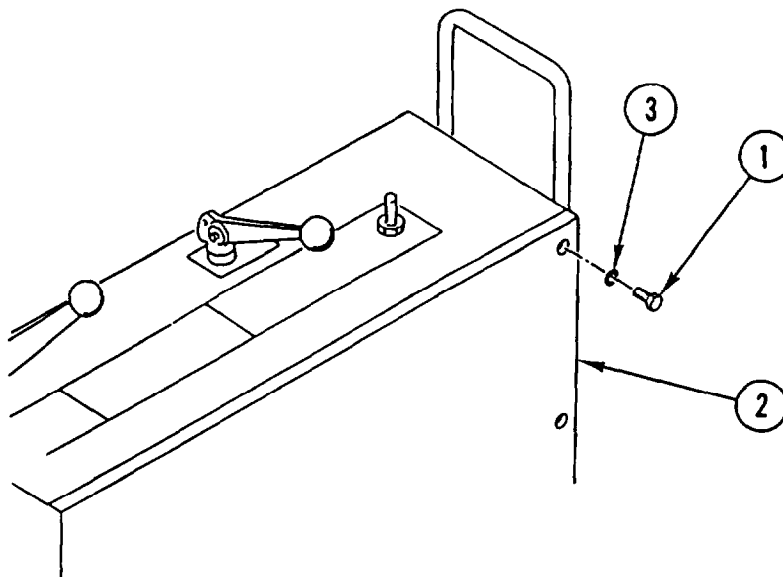

1. REMOVE SIX CAPSCREWS (1), SIX LOCK WASHERS (2), AND COVER (3). DISCARD LOCK WASHERS.

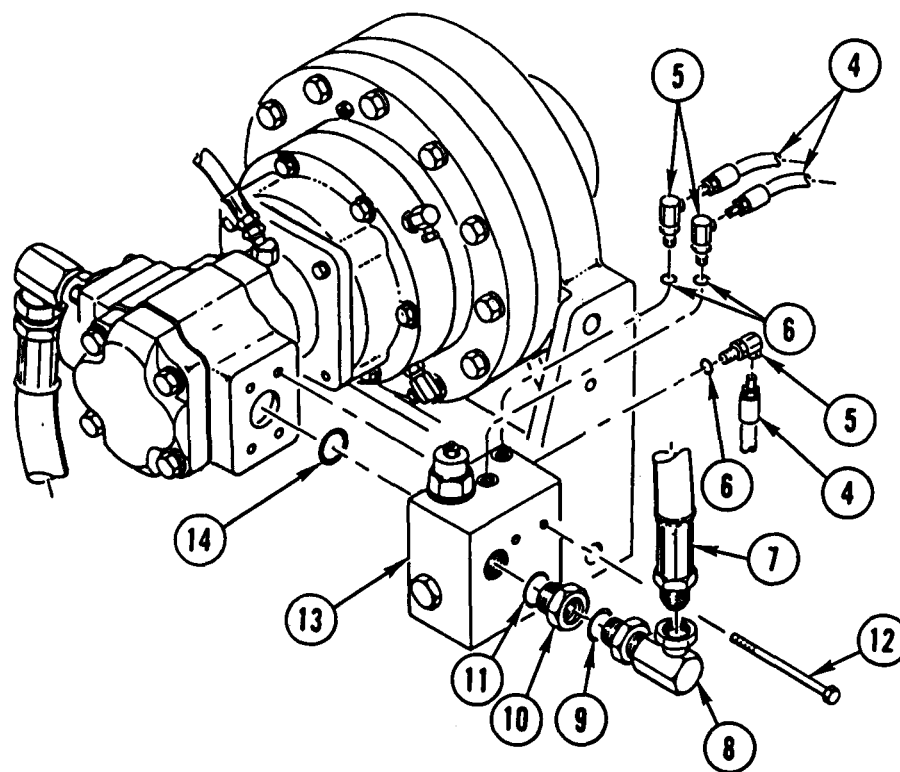

2. DISCONNECT THREE HOSES (4) AND REMOVE THREE ELBOWS (5) AND THREE PACKINGS (6). DISCARD PACKINGS.
3. DISCONNECT HOSE (7) FROM ELBOW (8).
4. REMOVE ELBOW (8), PACKING (9), BUSHING (10), AND PACKING (11). DISCARD PACKINGS.
5. REMOVE FOUR SCREWS (12), VALVE BODY (13), AND PACKING (14). DISCARD PACKING.

COUNTERBALANCE VALVE REPLACEMENT AND REPAIR (CONT)

DISASSEMBLY

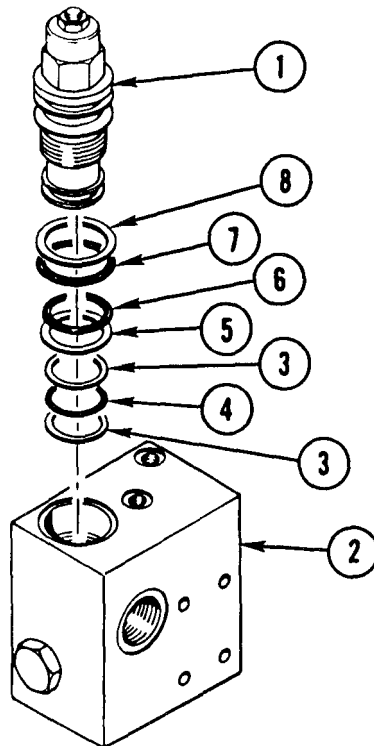

1. REMOVE VALVE (1) FROM VALVE BODY (2).
2. REMOVE AND DISCARD TWO BACKUP RINGS (3) AND PACKING (4).
3. REMOVE AND DISCARD BACKUP RING (5) AND PACKING (6).
4. REMOVE AND DISCARD PACKING (7) AND BACKUP RING (8).

CLEANING

Use general cleaning methods to clean all parts (page 2-30).

INSPECTION

Inspect all parts for wear or damage.

REPAIR

Use general repair methods to repair damaged parts (page 2-33).

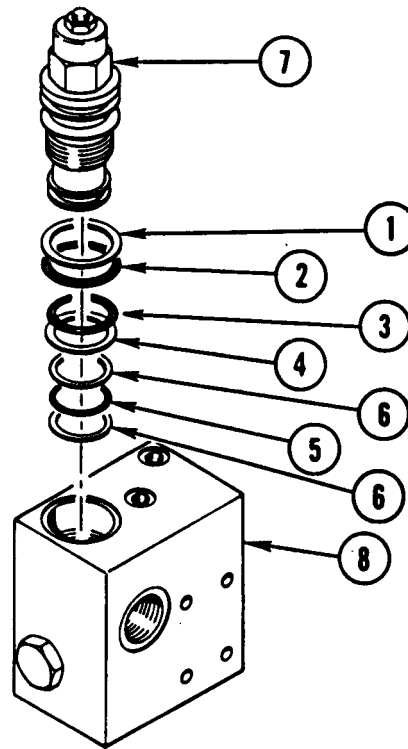
ASSEMBLY

1. INSTALL NEW BACKUP RING (1) AND NEW PACKING (2).
2. INSTALL NEW PACKING (3) AND NEW BACKUP RING (4).
3. INSTALL NEW PACKING (5) AND TWO NEW BACKUP RINGS (6) AS SHOWN.
4. INSTALL VALVE (7) IN VALVE BODY (8).

COUNTERBALANCE VALVE REPLACEMENT AND REPAIR (CONT)

INSTALLATION

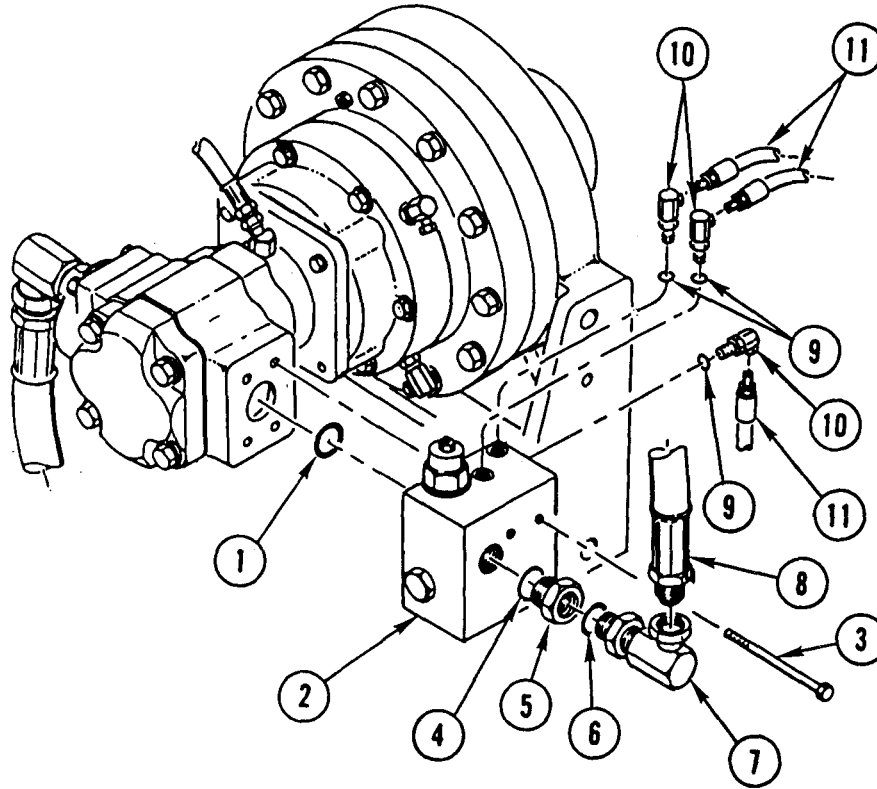

1. INSTALL NEW PACKING (1), VALVE BODY (2), AND FOUR SCREWS (3).
2. INSTALL NEW PACKING (4), BUSHING (5), NEW PACKING (6), AND ELBOW (7).
3. CONNECT HOSE (8) TO ELBOW (7).
4. INSTALL THREE NEW PACKINGS (9) AND THREE ELBOWS (10) AND CONNECT THREE HOSES (11).

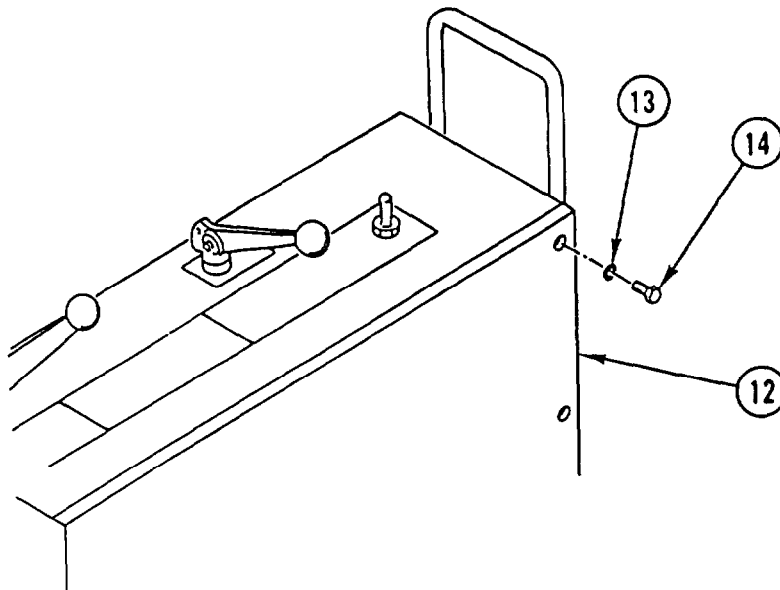

5. INSTALL COVER (12), SIX NEW LOCK WASHERS (13), AND SIX CAPSCREWS (14).

NOTE

Follow-on Maintenance:

Fill winch hydraulic oil tank (TM 9-2320-363-20).

SPEED CONTROL VALVE REPLACEMENT

This task covers: a. Removal b. Cleaning c. Inspection d. Installation

INITIAL SETUP

Applicable Configuration:

M916A1 and M916A2

Tools and Special Equipment:

Shop Equipment, SC 4910-95-CL-A31

Tool Kit, SC 5180-90-CL-N05

Materials/Parts:

Washer, Lock (2)	P/N 1395
Washer, Lock (6)	P/N 1295
Packing (2)	PIN 2507-12-12
Packing	P/N 0507-12-12

References:

TM 9-2320-363-20

Equipment Condition:

Reference	Condition	Description
TM 9-2320-363-20	Winch Hydraulic Oil Tank Drained	

REMOVAL

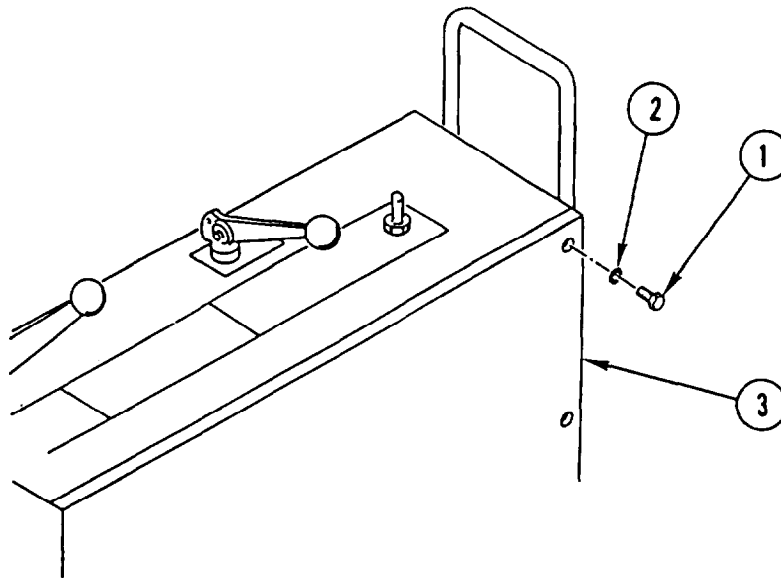

1. REMOVE SIX CAPSCREWS (1), SIX LOCK WASHERS (2), AND COVER (3). DISCARD LOCK WASHERS.

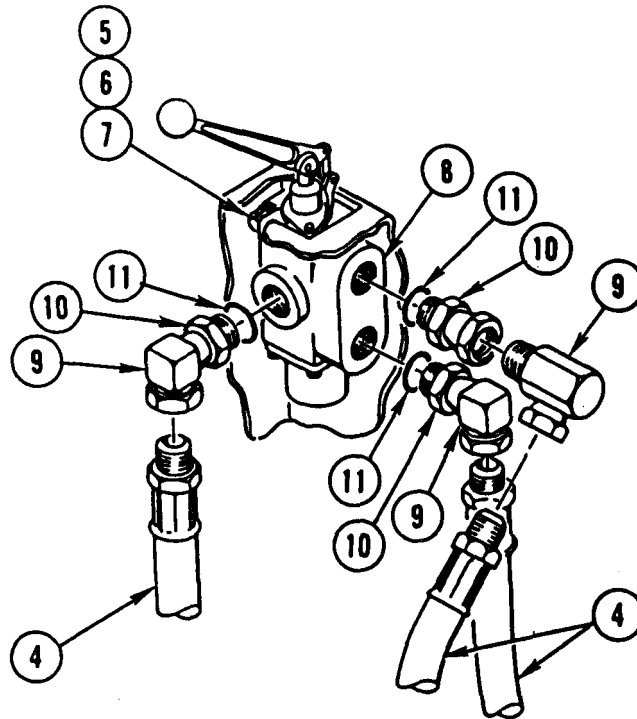

2. DISCONNECT THREE HYDRAULIC HOSE ASSEMBLIES (4).
3. REMOVE TWO NUTS (5), TWO LOCK WASHERS (6), TWO CAPSCREWS (7), AND SPEED CONTROL VALVE (8). DISCARD LOCK WASHERS.
4. REMOVE THREE ELBOWS (9), THREE ADAPTERS (10), AND THREE PACKINGS (11). DISCARD PACKINGS.

CLEANING

Use general cleaning methods to clean all parts (page 2-30).

INSPECTION

Inspect all parts for wear or damage.

SPEED CONTROL VALVE REPLACEMENT (CONT)

INSTALLATION

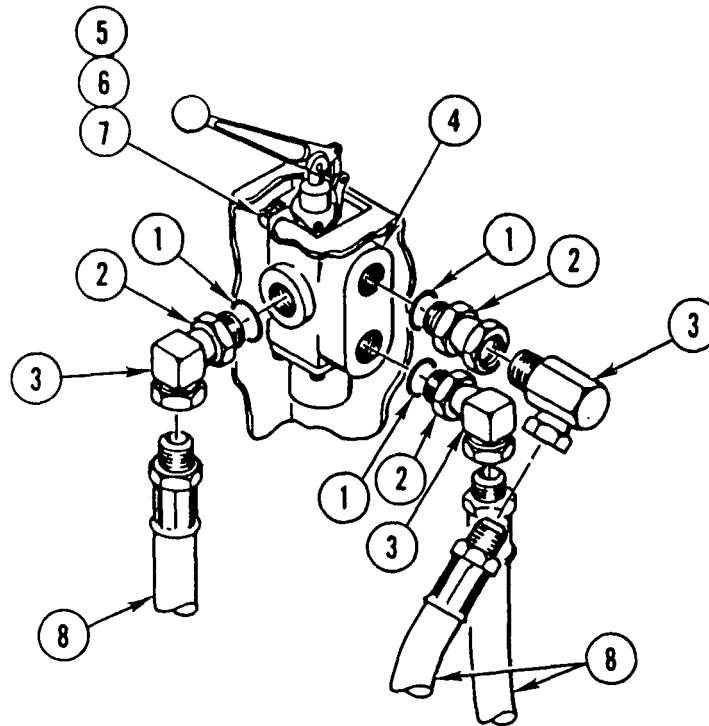

1. INSTALL THREE NEW PACKINGS (1), THREE ADAPTERS (2), AND THREE ELBOWS (3).
2. INSTALL SPEED CONTROL VALVE (4), TWO CAPSCREWS (5), TWO NEW LOCK WASHERS (6), AND TWO NUTS (7).
3. CONNECT THREE HYDRAULIC HOSE ASSEMBLIES (8).

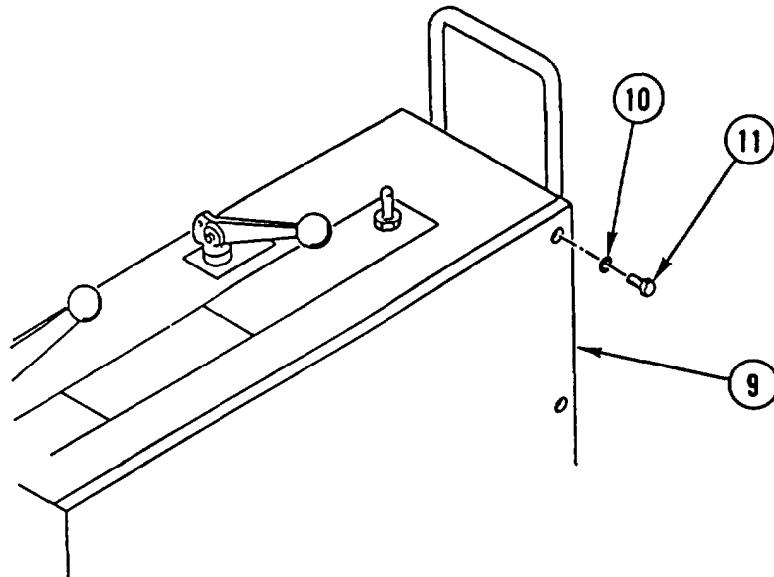

4. INSTALL COVER (9), SIX NEW LOCK WASHERS (10), AND SIX CAPSCREWS (11).

NOTE

Follow-on Maintenance:

Fill winch hydraulic oil tank (TM 9-2320-363-20).

DIRECTION CONTROL VALVE REPLACEMENT

This task covers: a. Removal b. Cleaning c. Inspection e. Installation

INITIAL SETUP

Applicable Configuration:

M916A1 and M916A2

Tools and Special Equipment:

Shop Equipment, SC 4910-95-CL-A31
Tool Kit, SC 5180-90-CL-N05

Materials/Parts:

Washer, Lock (3)	P/N 1395
Washer, Lock (6)	P/N 1295
Packing (3)	P/N 76728
Packing	P/N 0507-12-12

References:

TM 9-2320-363-20

Equipment Condition:

Reference	Condition	Description
TM 9-2320-363-20	Winch Hydraulic Oil Tank Drained	

REMOVAL

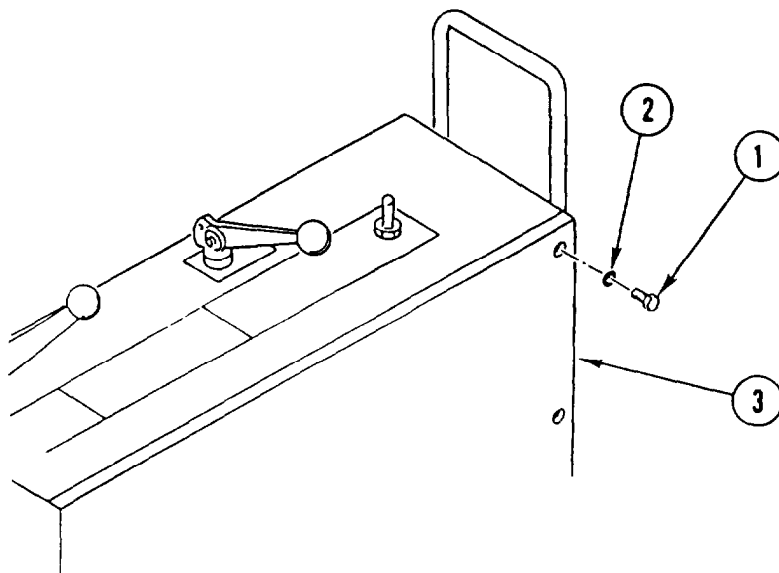

1. REMOVE SIX CAPSCREWS (1), SIX LOCK WASHERS (2), AND COVER (3). DISCARD LOCK WASHERS.

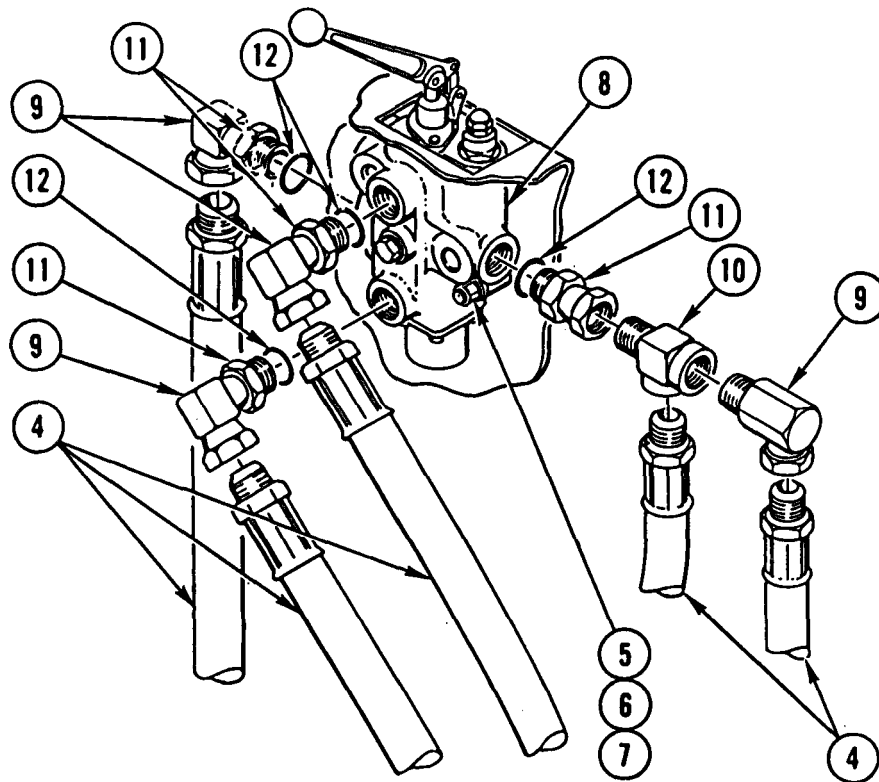

2. DISCONNECT FIVE HYDRAULIC HOSE ASSEMBLIES (4).
3. REMOVE THREE NUTS (5), THREE LOCK WASHERS (6), THREE CAPSCREWS (7), AND DIRECTION CONTROL VALVE (8). DISCARD LOCK WASHERS.
4. REMOVE FOUR ELBOWS (9), TEE (10), FOUR ADAPTERS (11), AND FOUR PACKINGS (12). DISCARD PACKINGS.

CLEANING

Use general cleaning methods to clean all parts (page 2-30).

INSPECTION

Inspect all parts for wear or damage.

DIRECTION CONTROL VALVE REPLACEMENT (CONT)

INSTALLATION

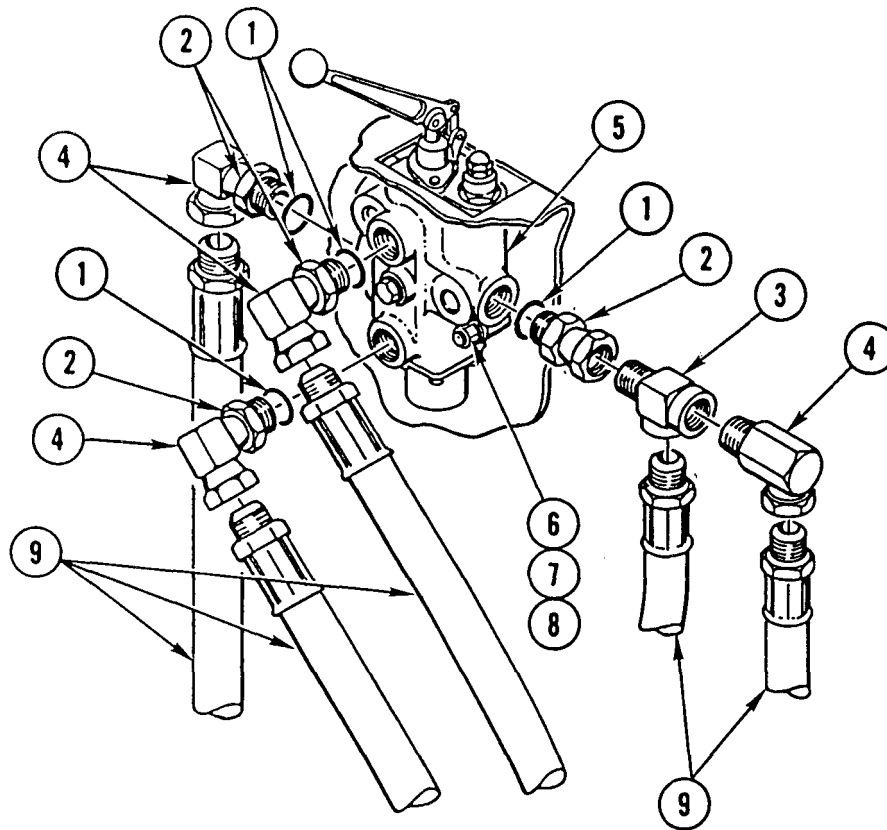

1. INSTALL FOUR NEW PACKINGS (1), FOUR ADAPTERS (2), TEE (3), AND FOUR ELBOWS (4).
2. INSTALL DIRECTION CONTROL VALVE (5), THREE CAPSCREWS (6), THREE NEW LOCK WASHERS (7), AND THREE NUTS (8).
3. CONNECT FIVE HYDRAULIC HOSE ASSEMBLIES (9).

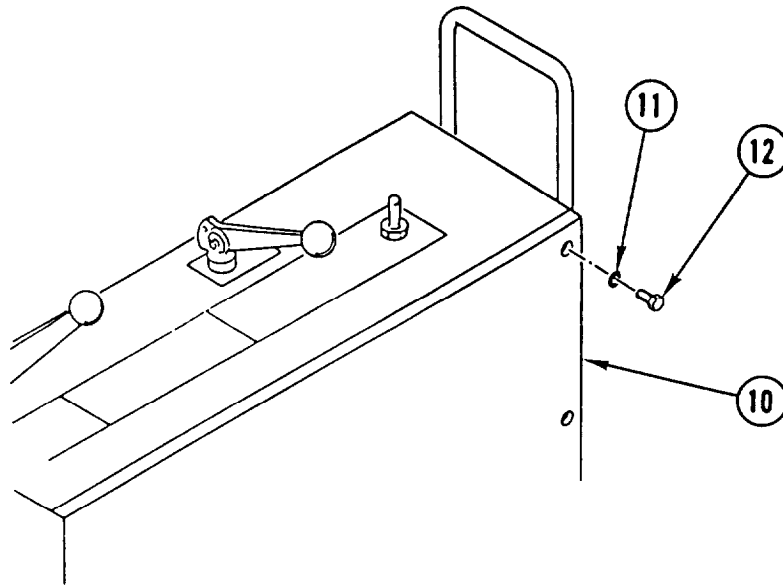

4. INSTALL COVER (10), SIX NEW LOCK WASHERS (11), AND SIX CAPSCREWS (12).

NOTE

Follow-on Maintenance:
Fill winch hydraulic oil tank (TM 9-2320-363-20).

HYDRAULIC WINCH FRAME REPLACEMENT

This task covers: a. Removal b. Cleaning c. Inspection d. Repair e. Installation

INITIAL SETUP

Applicable Configuration:

M916A1 and M916A2

Tools and Special Equipment:

Shop Equipment, SC 4910-95-CL-A31
Tool Kit, SC 5180-90-CL-N05

Materials/Parts:

Washer, Lock (16)

Washer, Lock (14)

Personnel Required: (2)

References:

TM 9-2320-363-10
TM 9-2320-363-20

Equipment Condition:

Reference

Condition Description

TM 9-2320-363-20

Winch Hydraulic Oil Tank
Removed

TM 9-2320-363-10

Spare Wheel Removed

TM 9-2320-363-20

Mud Flap Storage
Brackets Removed

TM 9-2320-363-20

Personal Gear Storage
Box and Mounting
Bracket Removed

TM 9-2320-363-20

Bl Storage Box and
Mounting Bracket
Removed

Page 11-9

Hydraulic Winch
Removed

Page 11-30

Direction Control Valve
Removed

Page 11-26

Speed Control Valve
Removed

TM 9-2320-363-20

Winch Speed Control
Switch Removed

TM 9-2320-363-20

Winch Lines and Fittings
Removed

REMOVAL

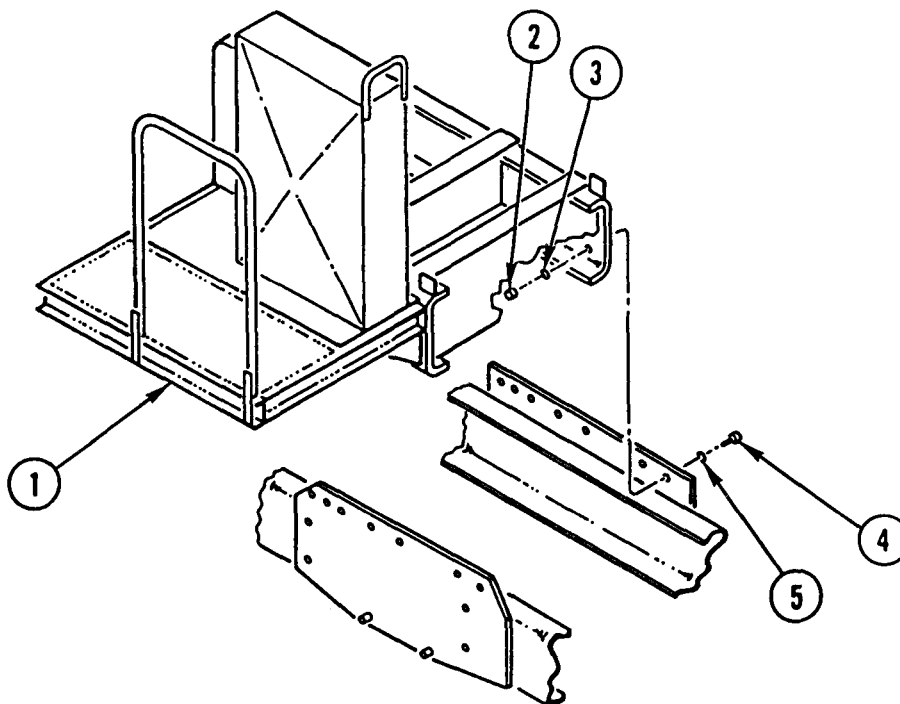

1. USING SUITABLE HOIST, SUPPORT HYDRAULIC WINCH FRAME (1) AND REMOVE 14 NUTS (2), 14 LOCK WASHERS (3), 14 SCREWS (4), 14 WASHERS (5), AND HYDRAULIC WINCH FRAME (1). DISCARD LOCK WASHERS.

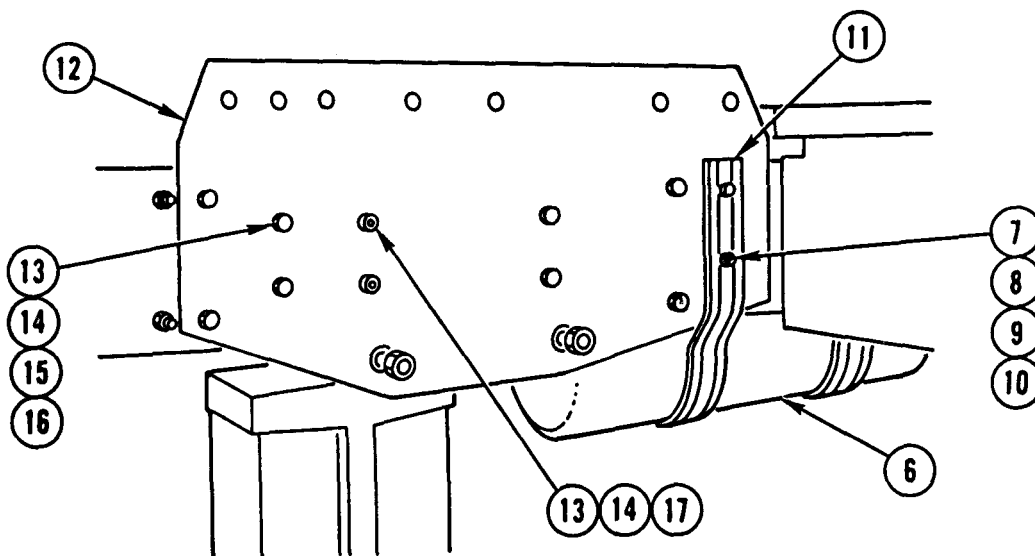

2. USING SUITABLE JACK STAND, SUPPORT AIR TANK (6) AND REMOVE TWO NUTS (7), TWO WASHERS (8), TWO SCREWS (9), TWO WASHERS (10), AND AIR TANK BRACKET (11).
3. USING SUITABLE HOIST, SUPPORT LEFT-HAND WINCH MOUNTING BRACKET (12) AND REMOVE 10 NUTS (13), 10 LOCK WASHERS (14), 8 SCREWS (15), 8 WASHERS (16), 2 SOCKET HEAD SCREWS (17), AND LEFT-HAND WINCH MOUNTING BRACKET (12). DISCARD LOCK WASHERS.

HYDRAULIC WINCH FRAME REPLACEMENT (CONT)

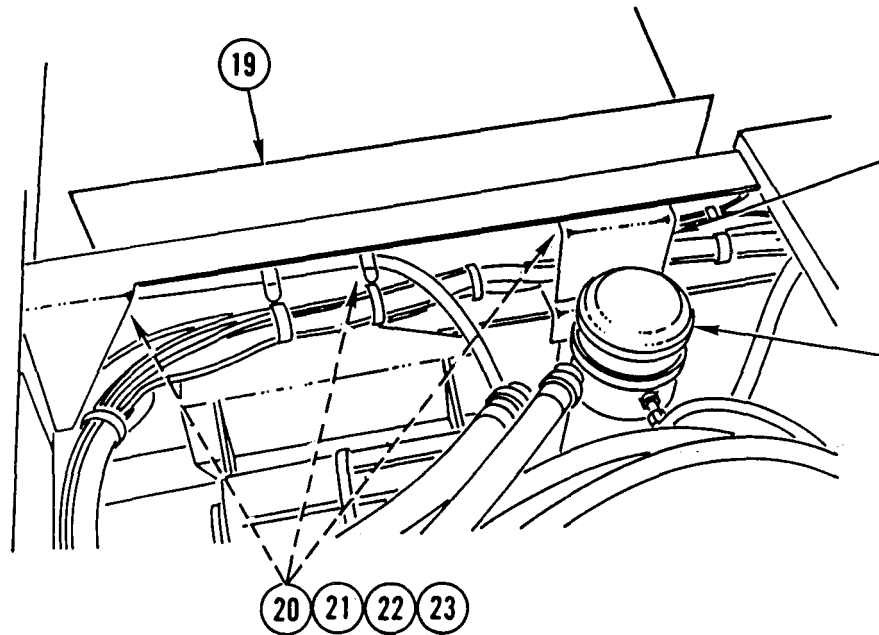

4. USING SUITABLE HOIST, SUPPORT AIR DRYER (18) AND RIGHT-HAND WINCH MOUNTING BRACKET (19). REMOVE SIX NUTS (20), SIX LOCK WASHERS (21), SIX SCREWS (22), SIX WASHERS (23), RIGHT-HAND WINCH MOUNTING BRACKET (19), AND AIR DRYER BRACKET (24). DISCARD LOCK WASHERS.

CLEANING

Use general cleaning methods to clean all parts (page 2-30).

INSPECTION

Inspect all parts for wear or damage.

REPAIR

Use general repair methods to repair damaged parts (page 2-33).

INSTALLATION

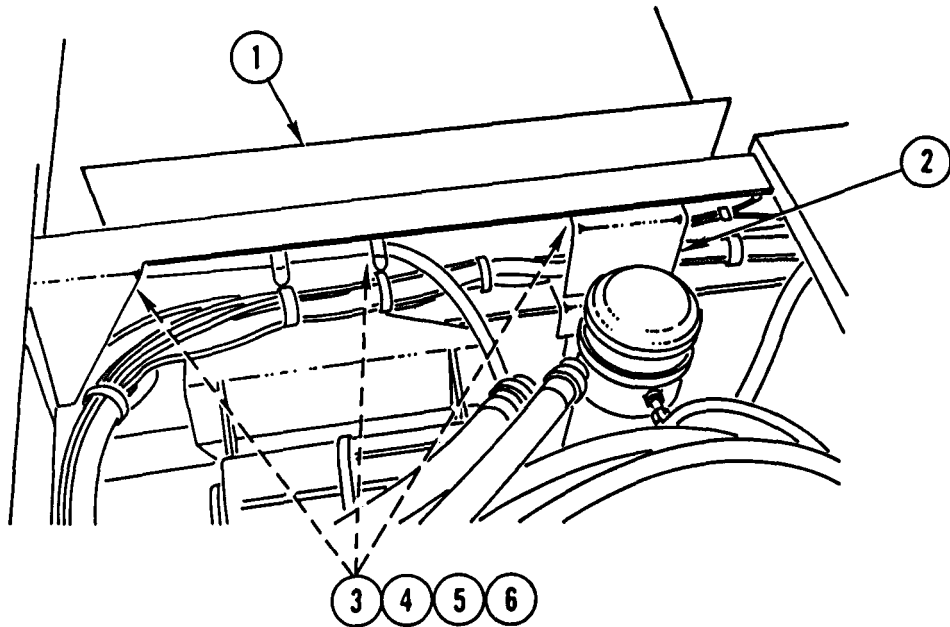

1. USING SUITABLE HOIST, INSTALL RIGHT-HAND WINCH MOUNTING BRACKET (1), AIR DRYER BRACKET (2), SIX WASHERS (3), SIX SCREWS (4), SIX NEW LOCK WASHERS (5), AND SIX NUTS (6).

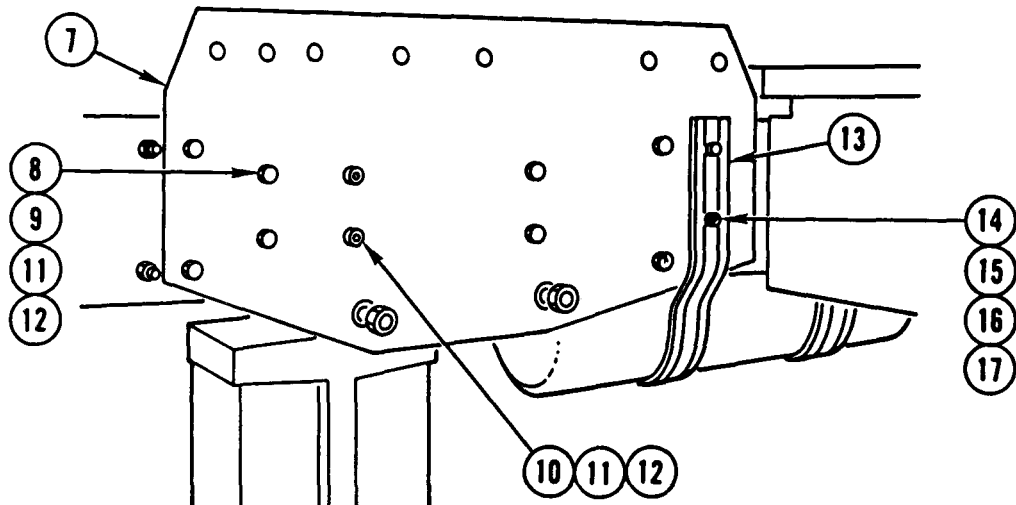

2. USING SUITABLE HOIST, INSTALL LEFT-HAND WINCH MOUNTING BRACKET (7), 8 WASHERS (8), 8 SCREWS (9), 2 SOCKET HEAD SCREWS (10), 10 NEW LOCK WASHERS (11), AND 10 NUTS (12).
3. INSTALL AIR TANK BRACKET (13), TWO WASHERS (14), TWO SCREWS (15), TWO WASHERS (16), AND TWO NUTS (17).

HYDRAULIC WINCH FRAME REPLACEMENT (CONT)

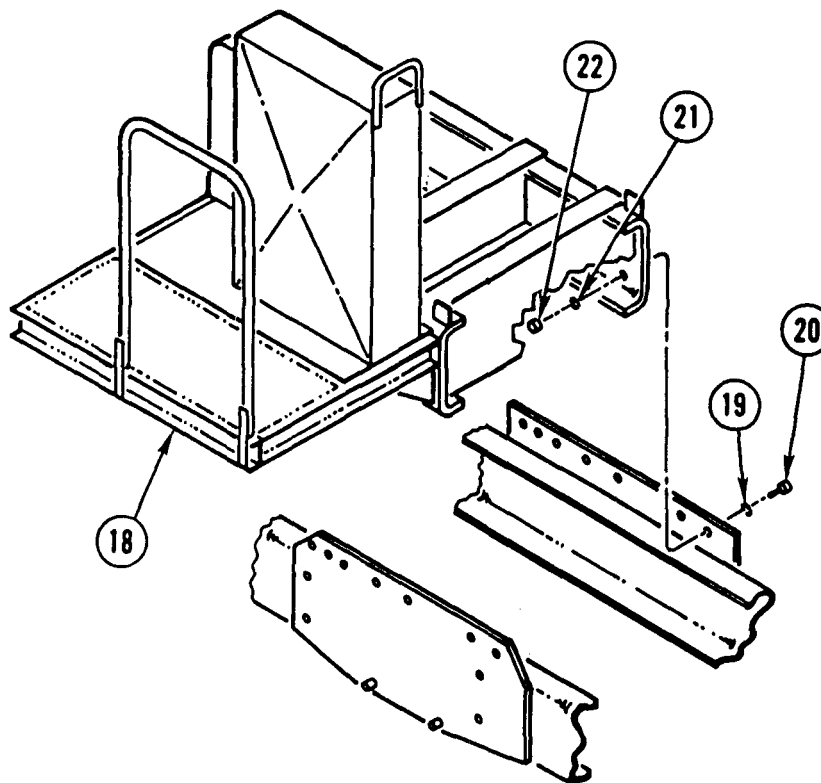

4. USING SUITABLE HOIST, INSTALL HYDRAULIC WINCH FRAME (18), 14 WASHERS (19), 14 SCREWS (20), 14 NEW LOCK WASHERS (21), AND 14 NUTS (22).

NOTE

Follow-on Maintenance:

- Install winch lines and fittings (TM 9-2320-363-20)
- Install winch speed control switch (TM 9-2320-363-20).
- Install speed control valve (page 11-26).
- Install direction control valve (page 11-30).
- Install hydraulic winch (page 11-9).
- Install Bil storage box and mounting bracket (TM 9-2320-363-20).
- Install personal gear storage box and mounting bracket (TM 9-2320-363-20).
- Install mud flap storage brackets (TM 9-2320-363-20).
- Install spare wheel (TM 9-2320-363-10).
- Install winch hydraulic oil tank (TM 9-2320-363-20).

WINCH HYDRAULIC OIL FILTER ADAPTER REPLACEMENT

This task covers: a. Removal b. Cleaning c. Inspection d. Installation

INITIAL SETUP

Applicable Configuration:

M916A1 and M916A2

Tools and Special Equipment:

Tool Kit, SC 5180-95-CL-N05

Materials/Parts:

Compound, Pipe Sealing Appendix B, Item 15

Tape, Teflon Appendix B, Item 60

References:

TM 9-2320-363-20

Equipment Condition:

Reference	Condition	Description
TM 9-2320-363-20	Oil Filter Element Removed	

General Safety Instructions:

WARNING

Spilled hydraulic fluid is very slippery. Wipe up any spilled fluid immediately. Failure to do so could result in serious injury to personnel.

WINCH HYDRAULIC OIL FILTER ADAPTER REPLACEMENT (CONT)

REMOVAL

1. LOOSEN TWO HOSE CLAMPS (1) AND DISCONNECT NIPPLE (2).

WARNING

Spilled hydraulic fluid is very slippery. Wipe up any spilled fluid immediately. Failure to do so could result in serious injury to personnel.

2. REMOVE HYDRAULIC OIL FILTER ADAPTER (3).
3. REMOVE AOAP VALVE (4).
4. REMOVE ELBOW (5) AND TWO NIPPLES (6).

CLEANING

Use general cleaning methods to clean all parts (page 2-30).

INSPECTION

Inspect all parts for wear or damage.

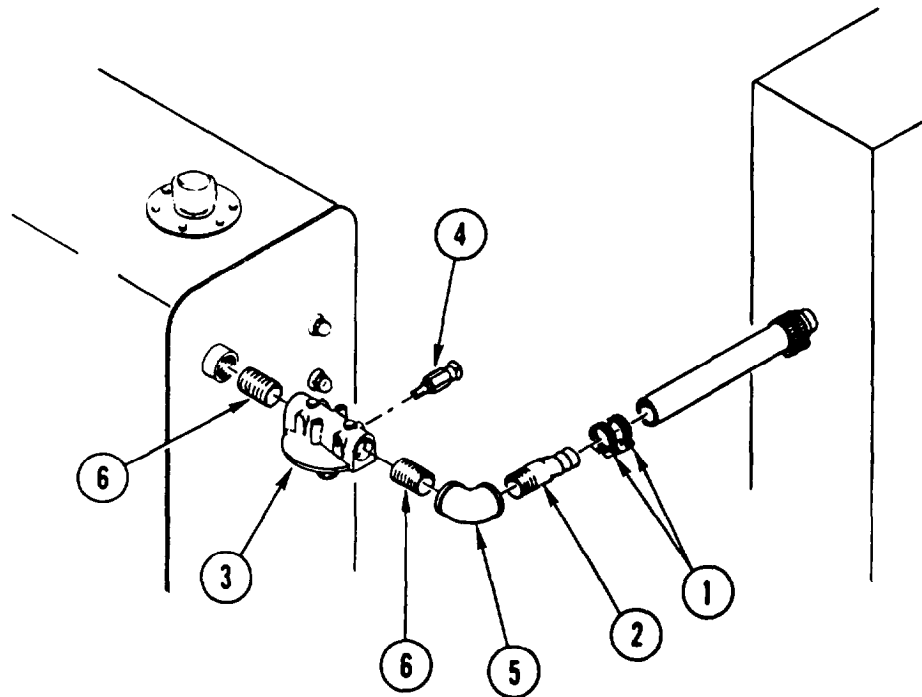

INSTALLATION

1. COAT THREADS OF TWO NIPPLES (6) WITH PIPE SEALING COMPOUND.
2. INSTALL TWO NIPPLES (6) AND ELBOW (5).
3. COAT THREADS OF AOAP VALVE (4) WITH PIPE SEALING COMPOUND OR TEFLON TAPE.
4. INSTALL AOAP VALVE (4).

WARNING

Spilled hydraulic fluid is very slippery. Wipe up any spilled fluid immediately. Failure to do so could result in serious injury to personnel.

5. INSTALL HYDRAULIC OIL FILTER ADAPTER (3).
6. CONNECT NIPPLE (2) AND TIGHTEN TWO HOSE CLAMPS (1).

NOTE

Follow-on Maintenance:
Install oil filter element (TM 9-2320-363-20).

POWER TAKE-OFF (PTO) REPLACEMENT

This task covers: a. Removal b. Cleaning c. Inspection d. Installation

INITIAL SETUP

Applicable Configuration:

All except M915A2

Tools and Special Equipment:

Tool Kit, SC 5180-95-CL-N05

Materials/Parts:

Kit P/N 328170-101X

Gasket P/N 23016683

Washer, Lock

References:

TM 9-2320-363-20

Equipment Condition:

Reference Condition Description

TM 9-2320-363-20 Air System Drained

TM 9-2320-363-20 Transmission Tunnel Access Cover Removed

General Safety Instructions:

WARNING

Spilled transmission fluid is very slippery. Wipe up any spilled fluid immediately. Failure to do so could result in serious injury to personnel.

REMOVAL

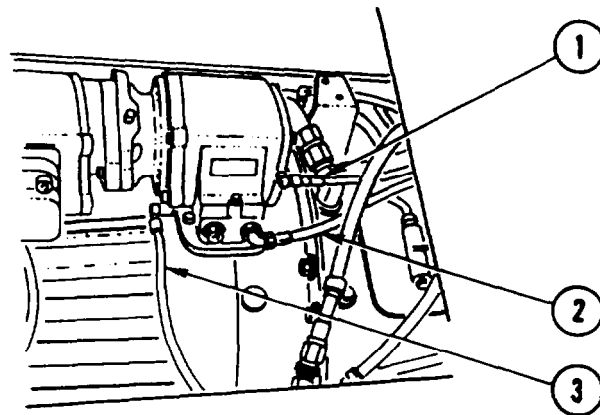

M916A1/M916A2
HYDRAULIC
PUMP SHOWN

NOTE

Tag air hoses prior to removal to aid in installation.

1. DISCONNECT TWO AIR HOSES (1 AND 2).

WARNING

Spilled transmission fluid is very slippery. Wipe up any spilled fluid immediately. Failure to do so could result in serious injury to personnel.

2. DISCONNECT LUBRICATION HOSE (3).

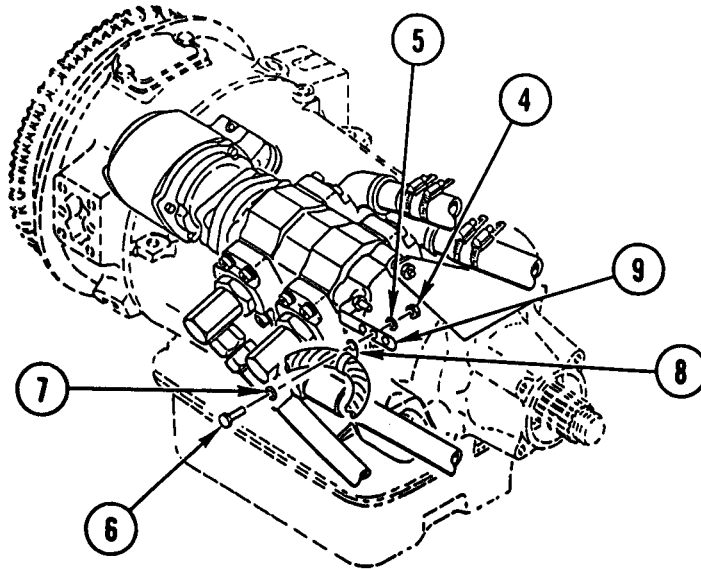

3. REMOVE NUT (4), WASHER (5), SCREW (6), WASHER (7), AND CLAMP (8) FROM BRACKET (9).

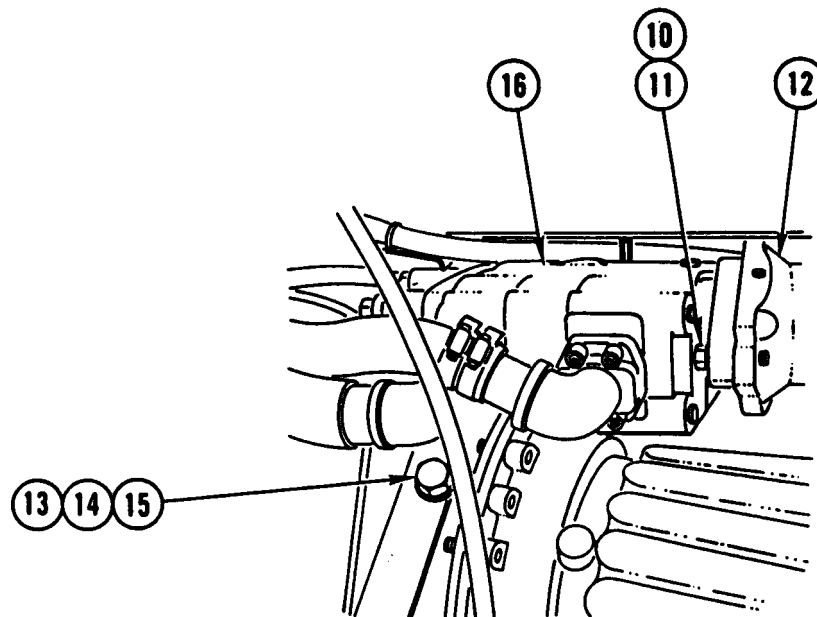

4. REMOVE TWO BOLTS (10) AND TWO WASHERS (11) FROM PTO (12).
5. REMOVE TWO BOLTS (13), TWO WASHERS (14), AND TWO LOCK WASHERS (15) AND MOVE HYDRAULIC PUMP (16) AWAY FROM PTO (12) APPROXIMATELY 0.75 IN. (19 mm). DISCARD LOCK WASHERS.

POWER TAKE-OFF (PTO) REPLACEMENT (CONT)

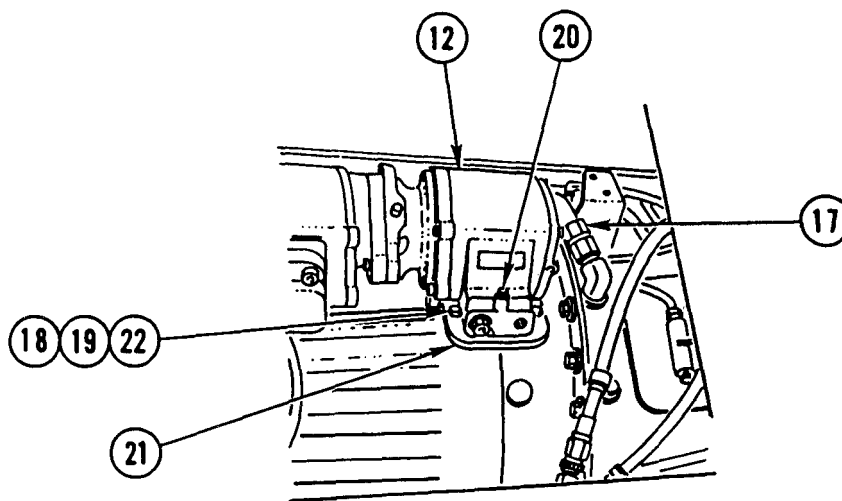

6. DISCONNECT HOSE (17).
7. REMOVE AND DISCARD FIVE NUTS (18), FIVE COPPER GASKETS (19), AND CAPSCREW (20).
8. REMOVE PTO (12) AND GASKET (21). DISCARD GASKET.
9. REMOVE AND DISCARD FIVE STUDS (22).

CLEANING

Use general cleaning methods to clean all parts (page 2-30).

INSPECTION

Inspect all parts for wear or damage.

INSTALLATION

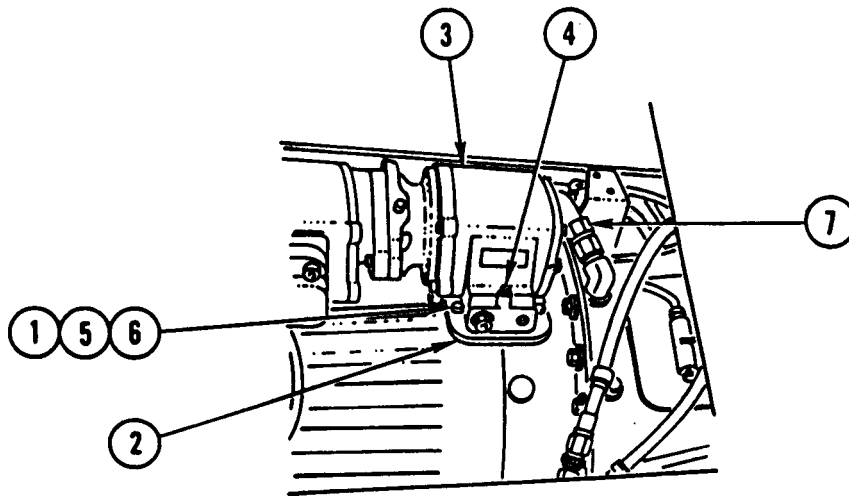

1. INSTALL FIVE NEW STUDS (1).
2. INSTALL NEW GASKET (2) AND PTO (3).
3. INSTALL NEW CAPSCREW (4), FIVE NEW COPPER GASKETS (5), AND FIVE NEW NUTS (6).
4. CONNECT HOSE (7).

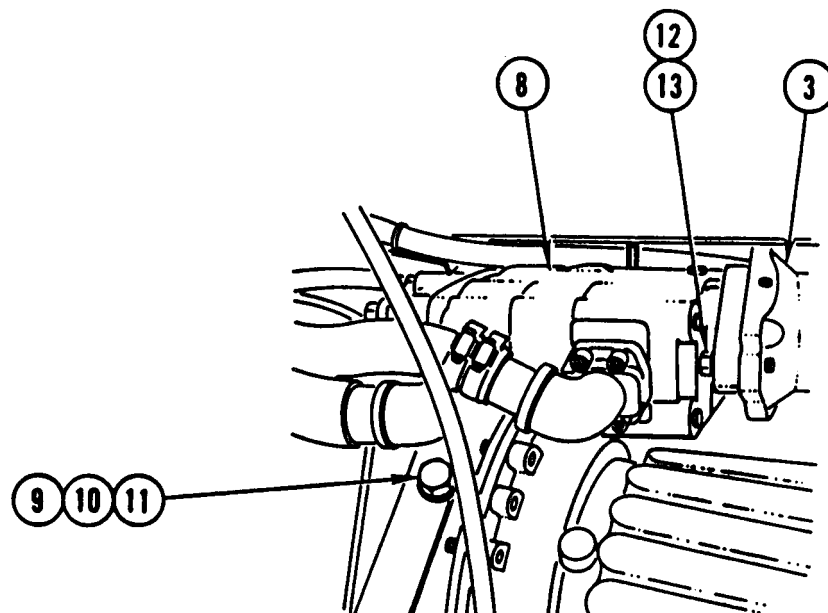

5. MOVE HYDRAULIC PUMP (8) UP TO PTO (3) AND INSTALL TWO NEW LOCK WASHERS (9), TWO WASHERS (10), AND TWO BOLTS (11).
6. INSTALL TWO WASHERS (12) AND TWO BOLTS (13).

POWER TAKE-OFF (PTO) REPLACEMENT (CONT)

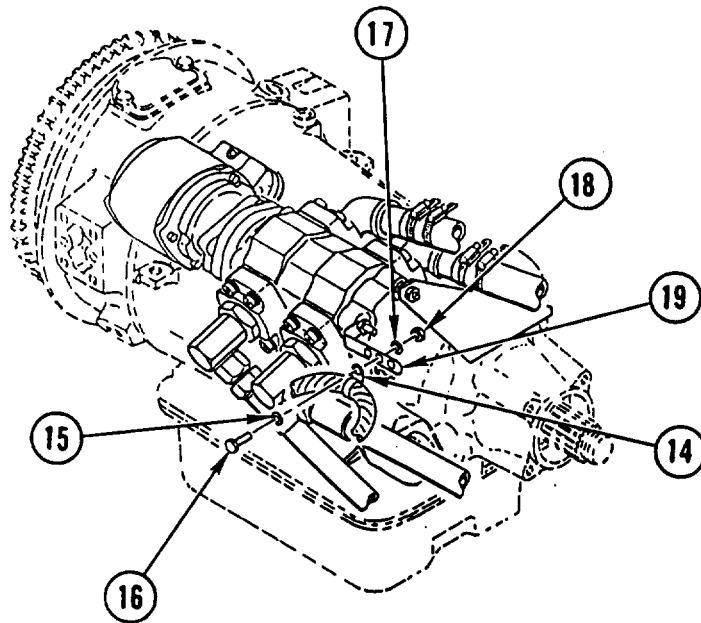

7. INSTALL CLAMP (14), WASHER (15), SCREW (16), WASHER (17), AND NUT (18) ON BRACKET (19).

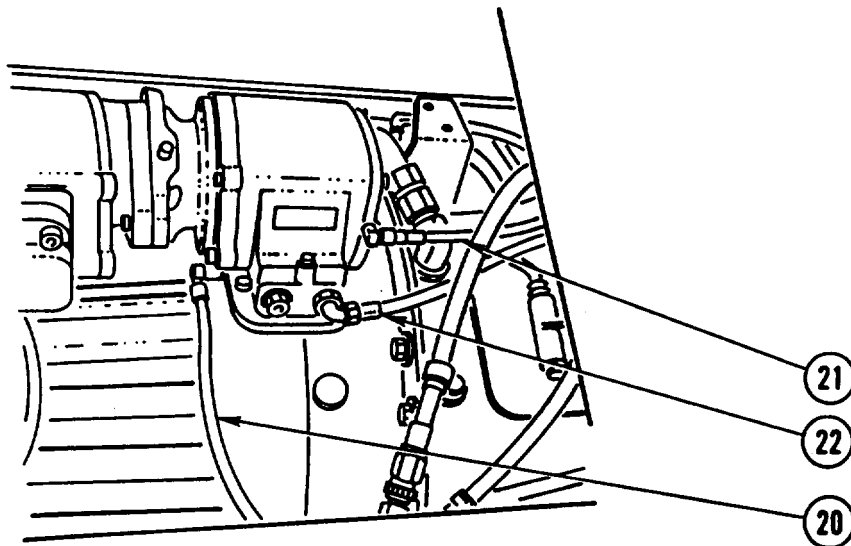

WARNING

Spilled transmission fluid is very slippery. Wipe up any spilled fluid immediately. Failure to do so could result in serious injury to personnel.

8. CONNECT LUBRICATION HOSE (20).
9. CONNECT TWO AIR HOSES (21 AND 22).

NOTE

Follow-on Maintenance:
Install transmission tunnel access cover (TM 9-2320-363-20).

CHAPTER 11.1
AIR CONDITIONING SYSTEM MAINTENANCE

OVERVIEW

This chapter illustrates and describes procedures for maintenance of the air conditioning system. A list of tasks contained in this chapter is shown below.

	Page
Air Conditioning System Refrigerant (R-134a) Maintenance (All Except M915A2 and M916A1)	11.1-2
Air Conditioner Compressor Replacement (All Except M915A2 and M916A1)	11.1-9
Air Compressor Receiver-Drier Replacement (All Except M915A2 and M916A1)	11.1-14
Air Conditioner Condenser Replacement (All Except M915A2 and M916A1)	11.1-16
Air Conditioner Hose Replacement (All Except M915A2 and M916A1)	11.1-18
Air Conditioner Fan Cycling Switch Replacement (All Except M915A2 and M916A1)	11.1-21
Air Conditioner Compressor Service (All Except M915A2 and M916A1)	11.1-23

AIR CONDITIONING SYSTEM REFRIGERANT (R-134a) MAINTENANCE

This task covers: a. Recovery b. Evacuating/Recycling c. Purging d. Flushing
e. Charging

INITIAL SETUP

Applicable Configuration:

All except M915A2 and M916A1

Tools and Special Equipment:

Shop Equipment, SC 4910-95-CL-A31
Tool Kit, SC 5180-90-CL-N26
Gage, Oil Level, 99-431
Recovery and Recycling System, 34400

Materials/Parts:

Receiver-Drier	P/N 088335-00
Cap and Plug Set	Appendix B, Item 7.1
Loctite	Appendix B, Item 33
Oil, Refrigerant	Appendix B, Item 43.1
Refrigerant, R-134a	Appendix B, Item 48.1

References:

TM 9-2320-363-10
TM 9-2320-363-20

Equipment Description:

Reference	Condition Description
TM 9-2320-363-10	Vehicle Blocked

General Safety Instructions:

WARNING

- Use care to prevent refrigerant from touching your skin or eyes, because liquid refrigerant, when exposed to air, quickly evaporates and will freeze skin or eye tissue. Serious injury or blindness could result if you come in contact with liquid refrigerant.
- Refrigerant R-134a air conditioning systems should not be pressure tested or leak tested with compressed air. Combustible mixtures of air and R-134a may form, resulting in a fire or explosion, which could cause personal injury.

RECOVERY

1. REMOVE THE CAPS FROM THE SUCTION AND DISCHARGE SERVICE VALVES. VALVES ARE LOCATED AT THE FIREWALL ON THE PASSENGER'S SIDE OF THE VEHICLE.
2. WEARING PROTECTIVE GOGGLES AND NON-LEATHER GLOVES, ATTACH THE RECOVERY/RECYCLING STATION'S HOSES TO THE VALVES.

NOTE

Push down firmly on the hose connectors until a clicking sound is heard. This will ensure that the coupler is locked.

- a. MAKE SURE THAT THE RECOVERY AND RECYCLING STATION'S VALVES ARE CLOSED.

- b. CONNECT THE RED HIGH-SIDE HOSE TO THE DISCHARGE SERVICE VALVE.
- c. CONNECT THE BLUE LOW-SIDE HOSE TO THE SUCTION SERVICE VALVE.

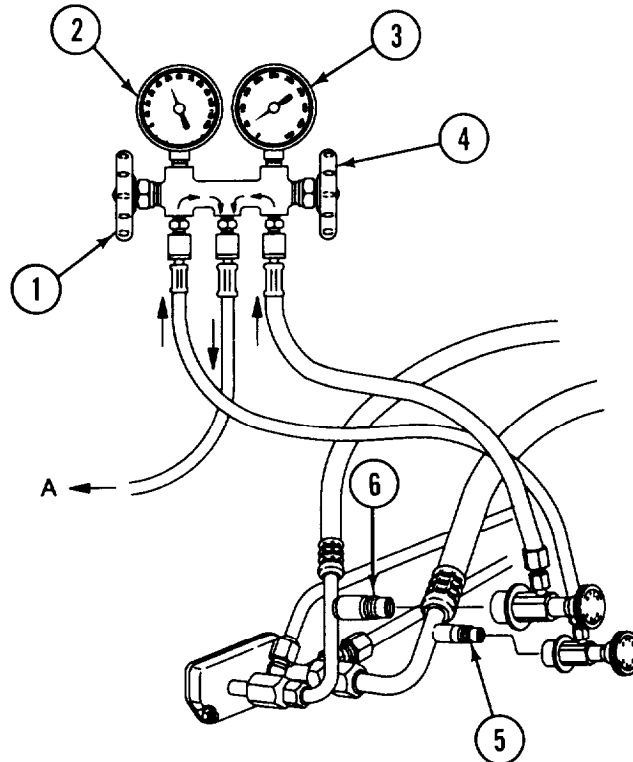

A. To Recovery Station

- 1. Manifold Suction Hand Valve (Open)
- 2. Low-Side Gauge
- 3. High-Side Gauge
- 4. Manifold Discharge Hand Valve (Open)
- 5. Suction Service Valve
- 6. Discharge Service Valve

- d. TURN THE KNOB CLOCKWISE ON EACH COUPLER TO OPEN THE SCHRADER VALVES.
3. FOLLOW THE RECOVERY AND RECYCLING STATION MANUFACTURERS INSTRUCTIONS AND RECOVER ALL OF THE REFRIGERANT FROM THE SYSTEM.

NOTE

- Always comply with all local regulations regarding refrigerant disposal. You may be subject to substantial penalties for improper disposal.
- Any time air conditioning system refrigerant is evacuated, replace receiver-drier.

4. REPLACE RECEIVER-DRIER (page 11.1-14).

NOTE

If the system is contaminated with moisture, all of the compressor oil must be replaced with clean oil. If the system is heavily contaminated with desiccant or grit, replace the compressor and expansion valve.

5. SERVICE AIR CONDITIONER COMPRESSOR (page 11.1-23).

AIR CONDITIONING SYSTEM REFRIGERANT (R-134a) MAINTENANCE
(CONT)

EVACUATING/RECYCLING

NOTE

The system must have been recovered and the compressor filled with the correct amount of refrigerant oil. Replace the receiver-drier if the system is opened.

1. WEARING PROTECTIVE GOGGLES AND NON-LEATHER GLOVES, ATTACH THE RECOVERY/RECYCLING STATION'S HOSES TO THE VALVES.

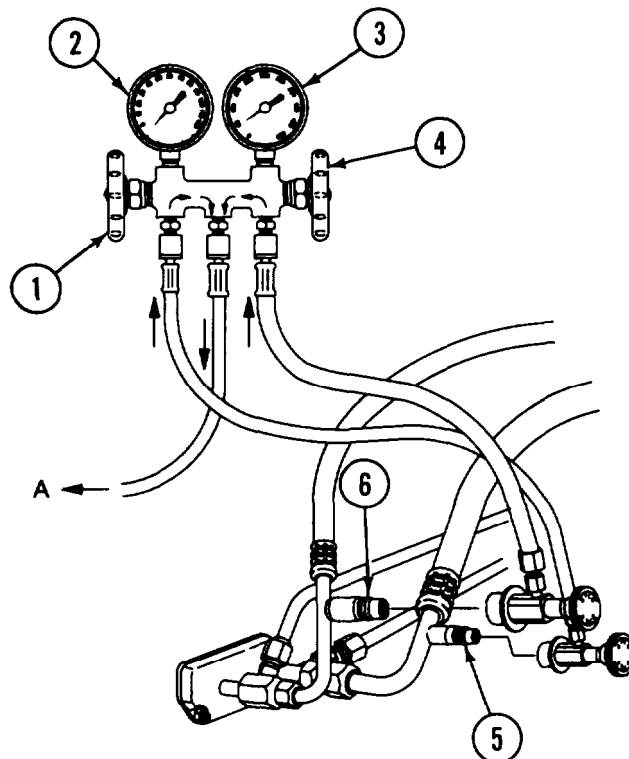

A. To Vacuum Pump

1. Manifold Suction Hand Valve (Open)
2. Low-Side Gauge
3. High-Side Gauge
4. Manifold Discharge Hand Valve (Open)
5. Suction Service Valve
6. Discharge Service Valve

NOTE

Push down firmly on the hose connectors until a clicking sound is heard. This will ensure that the coupler is locked.

- a. MAKE SURE THAT THE RECOVERY AND RECYCLING STATION'S VALVES ARE CLOSED.
 - b. CONNECT THE RED HIGH-SIDE HOSE TO THE DISCHARGE SERVICE VALVE.
 - c. CONNECT THE BLUE LOW-SIDE HOSE TO THE SUCTION SERVICE VALVE.
 - d. TURN THE KNOB CLOCKWISE ON EACH COUPLER TO OPEN THE SCHRADER VALVES.
2. FOLLOW THE RECOVERY AND RECYCLING STATION MANUFACTURER'S INSTRUCTIONS AND EVACUATE/RECYCLE THE REFRIGERANT SYSTEM.

PURGING

NOTE

Dry nitrogen gas is recommended for purging. A pressure regulator is required to regulate between 0 to 200 psi. Commercial cylinders of nitrogen contain pressures in excess of 2000 psi (13,780 kPa); this pressure must be reduced to 200 psi (1378 kPa) for purging.

1. RECOVER THE SYSTEM REFRIGERANT.
2. DISCONNECT BOTH ENDS OF THE LINE OR PART BEING PURGED. TIGHTLY CAP THE REST OF THE SYSTEM.
3. MAKE SURE VALVES 1,2, AND 3 ARE CLOSED.

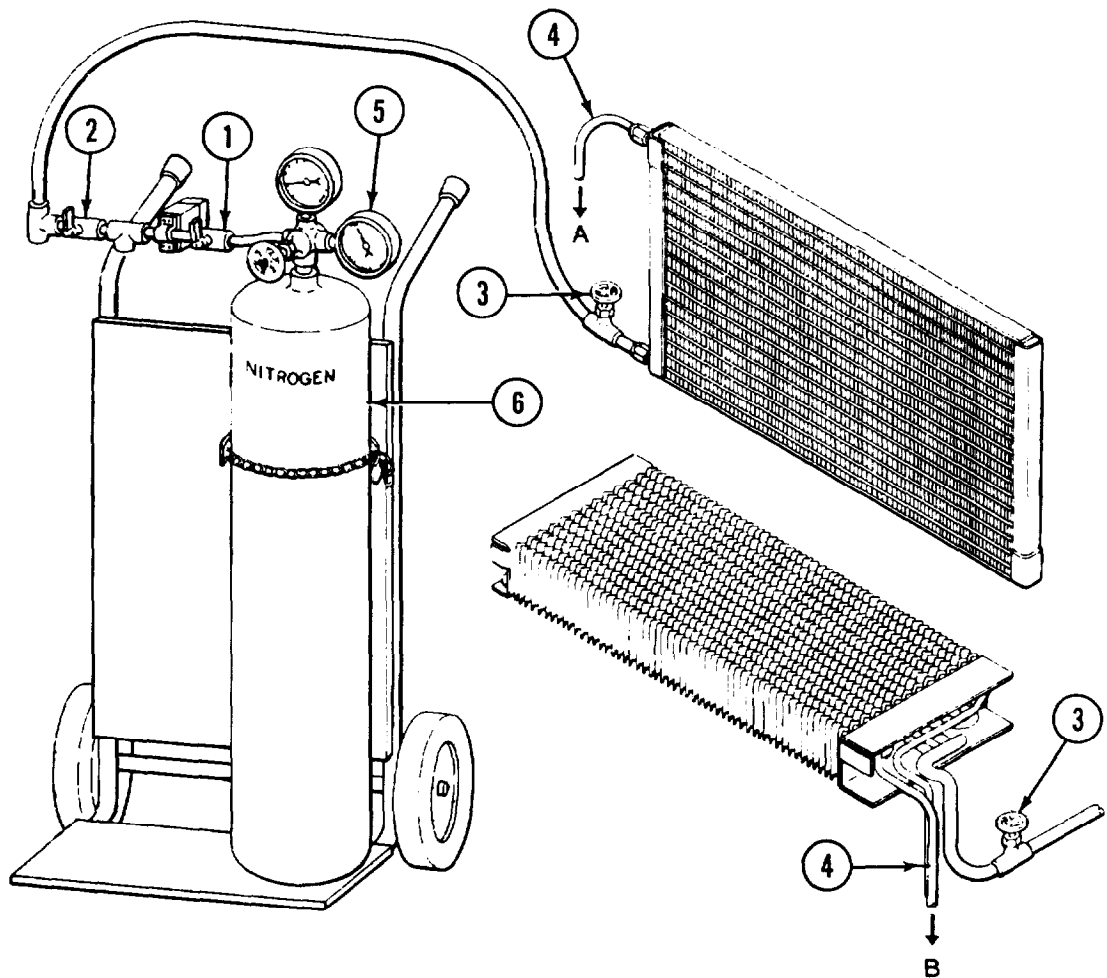

A. To Waste Container

B. To Recycling System Container

1. Nitrogen Bottle Control Valve
2. Purging Control Valve
3. Supply Line Valve

4. Drain Line
5. Nitrogen Bottle Regulator/Gauge
6. Nitrogen Bottle

AIR CONDITIONING SYSTEM REFRIGERANT (R-134a) MAINTENANCE
(CONT)

4. CONNECT THE SUPPLY LINE VALVE (3) TO THE OUTLET END OF THE PART OR LINE.
5. CONNECT THE DRAIN LINE (4) TO THE INLET END OF THE PART OR LINE.
6. PLACE THE OUTLET OF THE DRAIN LINE INTO A RECYCLING SYSTEM CONTAINER.
7. ADJUST THE NITROGEN BOTTLE REGULATOR (5) TO 200 psi (1378 kPa). OPEN THE NITROGEN BOTTLE CONTROL VALVE (1) AND THE PURGING CONTROL VALVE (2). THEN, SLOWLY OPEN THE SUPPLY LINE VALVE (3). CHECK THE DRAIN LINE (4) FOR GAS FLOW.

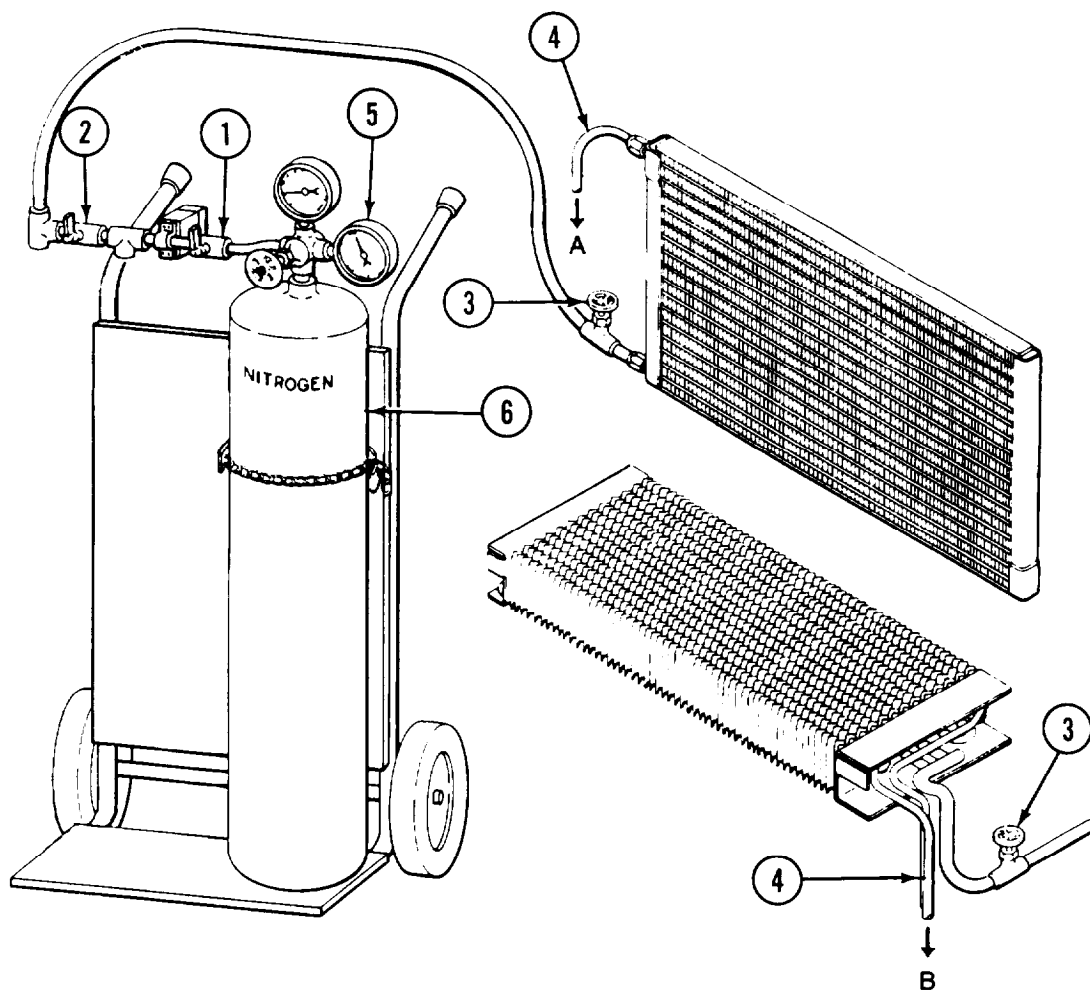

A. To Waste Container

B. To Recycling System Container

1. Nitrogen Bottle Control Valve
2. Purging Control Valve
3. Supply Line Valve

4. Drain Line
5. Nitrogen Bottle Regulator/Gauge
6. Nitrogen Bottle

8. LET THE NITROGEN FLOW AT 200 psi (1378 kPa) FOR 25 TO 30 SECONDS.
9. LOWER THE PRESSURE TO 4 psi (28 kPa) AND LET IT FLOW FOR 1 TO 2 MINUTES. IF THE LINE OR PART WAS VERY WET, ALLOW IT TO FLOW UNTIL THERE IS NO TRACE OF REFRIGERANT OIL OR SOLID BITS OF DIRT OR GRIT FLOWING FROM THE DRAIN TUBE.
10. CLOSE THE NITROGEN BOTTLE CONTROL VALVE AND THE PURGING CONTROL VALVE FIRST, THEN CLOSE THE SUPPLY LINE VALVE.
11. DISCONNECT THE SUPPLY LINE VALVE AND THE DRAIN LINE. TIGHTLY CAP BOTH ENDS OF THE PART OR LINE.

FLUSHING

1. RECOVER THE SYSTEM REFRIGERANT.
2. DISCONNECT BOTH ENDS OF THE LINE OR PART BEING FLUSHED. TIGHTLY CAP THE LINES TO THE REST OF THE SYSTEM.
3. HEAT R-134a IN A DIAL-A-CHARGE OR PRESSURIZE THE REFRIGERANT AS RECOMMENDED BY THE MANUFACTURER.
4. CONNECT THE DIAL-A-CHARGE OUTLET HOSE TO THE OUTLET SIDE OF THE SYSTEM (THIS WILL ENSURE THAT R-134a WILL FLOW IN THE REVERSE DIRECTION OF NORMAL FLOW).
5. CONNECT A LINE FROM THE INLET SIDE OF THE SYSTEM TO A RECOVERY/RECYCLING STATION.

NOTE

If the system is extremely contaminated, install a receiver-drier inline as a pre-filter for the recovery/recycling station.

6. TURN ON THE RECOVERY/RECYCLING STATION AND OPEN THE OUTLET VALVE FOR THE DIAL-A-CHARGE. ALLOW ABOUT 2 POUNDS (1 KILOGRAM) OF R-134a TO FLOW THROUGH THE SYSTEM.
7. CLOSE THE SUPPLY LINE VALVE AND WAIT FOR THE RECOVERY STATION TO SHUT OFF.
8. DISCONNECT THE SUPPLY LINE AND THE DRAIN LINE FROM THE DIAL-A-CHARGE AND THE RECOVERY STATION. CONNECT THE LINES TO A NITROGEN BOTTLE.
9. PURGE THE SYSTEM AND CHECK THE COLLECTION BOTTLE FOR CONTAMINANTS. REPEAT THE PROCESS IF NEEDED.
10. DISCONNECT THE LINES FROM THE PART AND TIGHTLY CAP BOTH ENDS OF THE PART.

AIR CONDITIONING SYSTEM REFRIGERANT (R-134a) MAINTENANCE (CONT)

CHARGING

NOTE

Before charging, the system must be recovered and evacuated with the recovery and recycling station connected to the service and discharge port connections.

1. OBTAIN ENOUGH REFRIGERANT TO FULLY CHARGE THE SYSTEM. SET THE TANK ON A SCALE AND WEIGH IT SO THAT THE CORRECT AMOUNT OF REFRIGERANT ENTERS THE SYSTEM. THIS PREVENTS OVERCHARGING, WHICH COULD DAMAGE THE COMPRESSOR.
2. CHARGE THE REFRIGERANT SYSTEM.

NOTE

If equipped with a recovery, recycling, and recharging station, charge the system on the high side following the manufacturers's instructions. If charging from a bulk container, do the following steps (a-d).

- a. TURN THE TANK (BULK CONTAINER) UPSIDE DOWN. WITH THE ENGINE OFF, OPEN THE HIGH-SIDE HAND VALVE. **DO NOT** OPEN THE LOW-SIDE HAND VALVE.
- b. ALLOW REFRIGERANT TO ENTER THE SYSTEM UNTIL THE CORRECT CHARGE (BY WEIGHT) HAS ENTERED. THEN, CLOSE THE HIGH-SIDE HAND VALVE.
- c. START THE ENGINE AND RUN IT AT 1500 RPM. SET THE CAB AIR CONDITIONER CONTROLS AT MAXIMUM COOLING AND FAN SPEED; THE REFRIGERANT COMPRESSOR MUST ENGAGE.
- d. IF A FULL CHARGE DID NOT ENTER THE SYSTEM, PLACE THE TANK (BULK CONTAINER) IN THE UPRIGHT POSITION, THEN OPEN THE **LOW-SIDE VALVE** TO DRAW VAPOR INTO THE SYSTEM; LEAVE THE VALVE OPEN UNTIL THE CORRECT WEIGHT OF REFRIGERANT HAS ENTERED THE SYSTEM, THEN CLOSE THE LOW-SIDE VALVE.

NOTE

If refrigerant is slow to enter the system because of low outside temperatures, vaporization can be quickened by placing the refrigerant tank in a tub of warm water, no warmer than 125°F (52°C).

3. DISCONNECT THE HIGH-SIDE HOSE. WITH THE ENGINE RUNNING, OPEN THE LOW-SIDE AND HIGH-SIDE HOSE VALVES TO RECOVER THE REFRIGERANT FROM THE LINES.
4. SHUT DOWN THE ENGINE.

NOTE

Follow-on Maintenance:

Leak test air conditioning system (TM 9-2320-363-20).

Check operation of air conditioning system (TM 9-2320-363-10).

AIR CONDITIONER COMPRESSOR REPLACEMENT

This Task Covers: a. Removal b. Installation

INITIAL SETUP

Applicable Configuration:

All except M915A2 and M916A1

Tools and Special Equipment:

Tool Kit, SC 5180-90-CL-N26
Shop Equipment, SC 4910-95CL-A31

Materials/Parts:

Nut, Lock (2)	P/N 210980 010010
Washer, Lock (6)	P/N 23-09318-011
Packing, Preformed	P/N 011C944-70
Packing, Preformed	P/N 015C944-70
Receiver-Drier	P/N 088335-00
Cap and Plug Set	Appendix B, Item 7.1
Loctite	Appendix B, Item 33
Oil, Refrigerant	Appendix B, Item 43.1
Tags, Identification	Appendix B, Item 55

References:

TM 9-2320-363-10
TM 9-2320-363-20

Equipment Condition:

Reference	Condition Description
TM 9-2320-363-20	Batteries Disconnected
TM9-2320-363-20	Alternator Belt Removed
Page 11.1-2	Refrigerant Recovered

General Safety Instructions:

WARNING

- Use care to prevent refrigerant from touching your skin or eyes, because liquid refrigerant, when exposed to air, quickly evaporates and will freeze skin or eye tissue. Serious injury or blindness could result if you come in contact with liquid refrigerant.
- Refrigerant R-134a air conditioning systems should not be pressure tested or leak tested with compressed air. Combustible mixtures of air and R-134a may form, resulting in a fire or explosion, which could cause personal injury.

NOTE

If the air conditioner compressor is being removed as an equipment condition for engine replacement, DO NOT disconnect refrigerant hoses and fittings and only perform the following four steps.

- Disconnect compressor clutch electrical lead.
- Cut cable ties securing refrigerant hoses.
- Remove compressor mounting bolts.
- Move compressor from mounting bracket to truck frame and secure in place to prevent damage.

AIR CONDITIONER COMPRESSOR REPLACEMENT (CONT)

REMOVAL

1. DISCONNECT CONNECTOR (1) OF COMPRESSOR (2) FROM CONNECTOR (3).

CAUTION

Water and dirt can damage the refrigerant system. Five minutes of not being capped is the limit for any hose or component. Do not blow shop air through the refrigerant hoses; shop air is wet (humid).

NOTE

Do not disconnect or connect refrigerant fittings using only one wrench. Hold one fitting in place using a wrench, and turn the other fitting with a second wrench.

2. TAG AND DISCONNECT TWO HOSES (4) FROM TOP OF COMPRESSOR (2). INSTALL PLUGS IN LINES AND DISCARD PREFORMED PACKING (5).
3. REMOVE TWO SCREWS (6) WASHERS (7) LOCK NUTS (8) AND COMPRESSOR (2) WITH BRACKET (9) ATTACHED. DISCARD LOCK NUTS.
4. SECURE BRACKET (9) IN SOFT JAWED VISE.
5. REMOVE SCREW (10), WASHER (11) AND SPACER (12) FROM ALTERNATOR ADJUSTMENT BOLT (13).
6. REMOVE SCREW (14) AND LOCK WASHER (15) FROM SIDE OF COMPRESSOR BRACKET (9). DISCARD LOCK WASHER.
7. REMOVE THREE SCREWS (16) AND LOCK WASHERS (17) FROM SIDE OF COMPRESSOR BRACKET (9). DISCARD LOCK WASHERS.
8. REMOVE TWO SCREWS (18) AND LOCK WASHERS (19) FROM UNDERSIDE OF COMPRESSOR BRACKET (9).
9. REMOVE COMPRESSOR (2) FROM BRACKET (9).

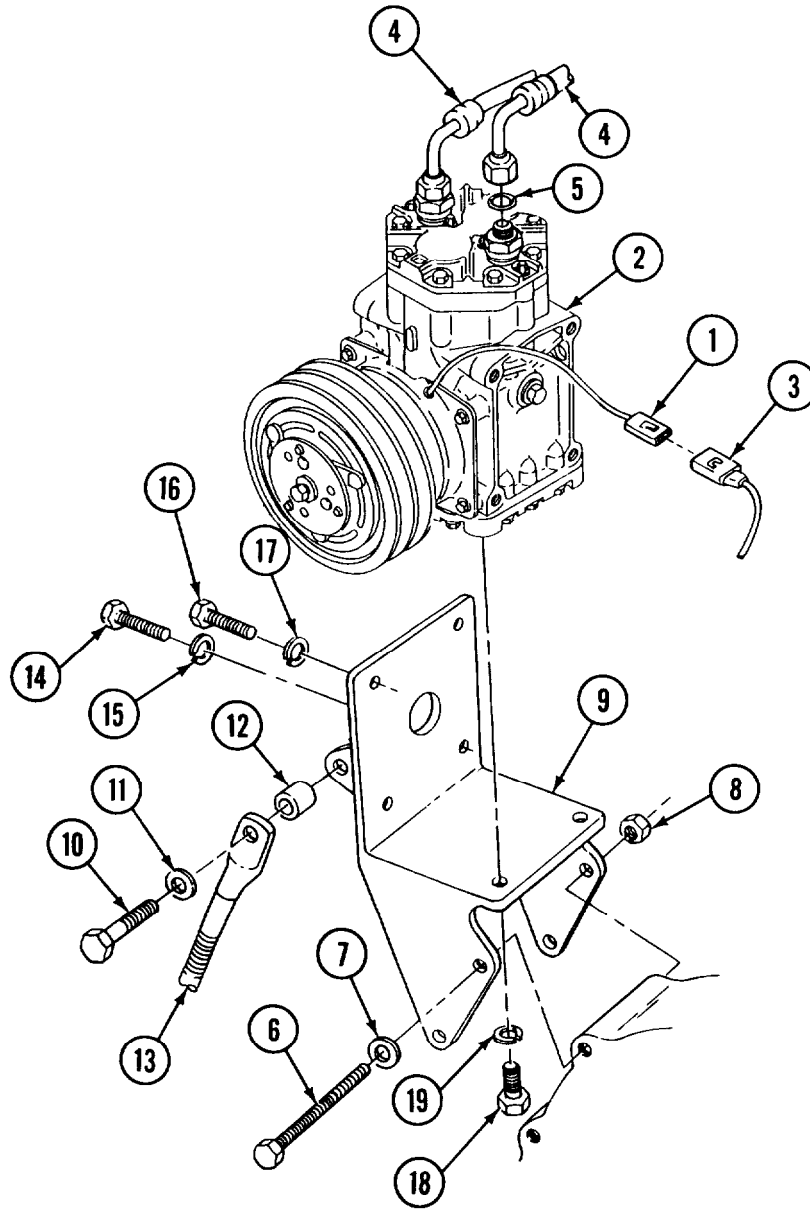

AIR CONDITIONER COMPRESSOR REPLACEMENT (CONT)

INSTALLATION

WARNING

- Use care to prevent refrigerant from touching your skin or eyes, because liquid refrigerant, when exposed to air, quickly evaporates and will freeze skin or eye tissue. Serious injury or blindness could result if you come in contact with liquid refrigerant.
- Refrigerant R-134a air conditioning systems should not be pressure tested or leak tested with compressed air. Combustible mixtures of air and R-134a may form, resulting in a fire or explosion which could cause personal injury.

1. WITH BRACKET (1) SECURED IN SOFT JAWED VISE, POSITION COMPRESSOR (2) ONTO BRACKET (1) AND ALIGN UNDERSIDE MOUNTING HOLES ON COMPRESSOR WITH MOUNTING HOLES ON BRACKET.
2. INSTALL TWO SCREWS (3) AND NEW LOCK WASHERS (4). HAND TIGHTEN.
3. ON SIDE OF BRACKET (1), INSTALL THREE SCREWS (5) AND NEW LOCK WASHERS (6). HAND TIGHTEN.
4. ON SIDE OF BRACKET (1) INSTALL SCREW (7) AND NEW LOCK WASHER (8). HAND TIGHTEN.
5. INSTALL SPACER (9) WASHER (10), AND SCREW (11) TO ALTERNATOR ADJUSTMENT BOLT (12).

NOTE

Torque underside mounting screws before torquing side mounting screws.

6. TORQUE UNDERSIDE SCREWS (3) TO 20-25 LB-FT(27-34 N.m).
7. TORQUE SIDE MOUNTING SCREWS (5 AND 7) TO 20-25 LB-FT (27-34 N.m).
8. POSITION BRACKET (1) WITH COMPRESSOR (2) ONTO ENGINE BLOCK AND INSTALL TWO SCREWS (13), NEW LOCK WASHERS (14) AND NEW LOCK NUTS (15).
9. CONNECT TWO HOSES (16) TO TOP OF COMPRESSOR (2) USING NEW PREFORMED PACKINGS (17) COATED WITH REFRIGERANT OIL AND LOCTITE APPLIED TO MALE FITTINGS.
10. CONNECT CONNECTOR (18) OF COMPRESSOR (2) TO CONNECTOR (19).

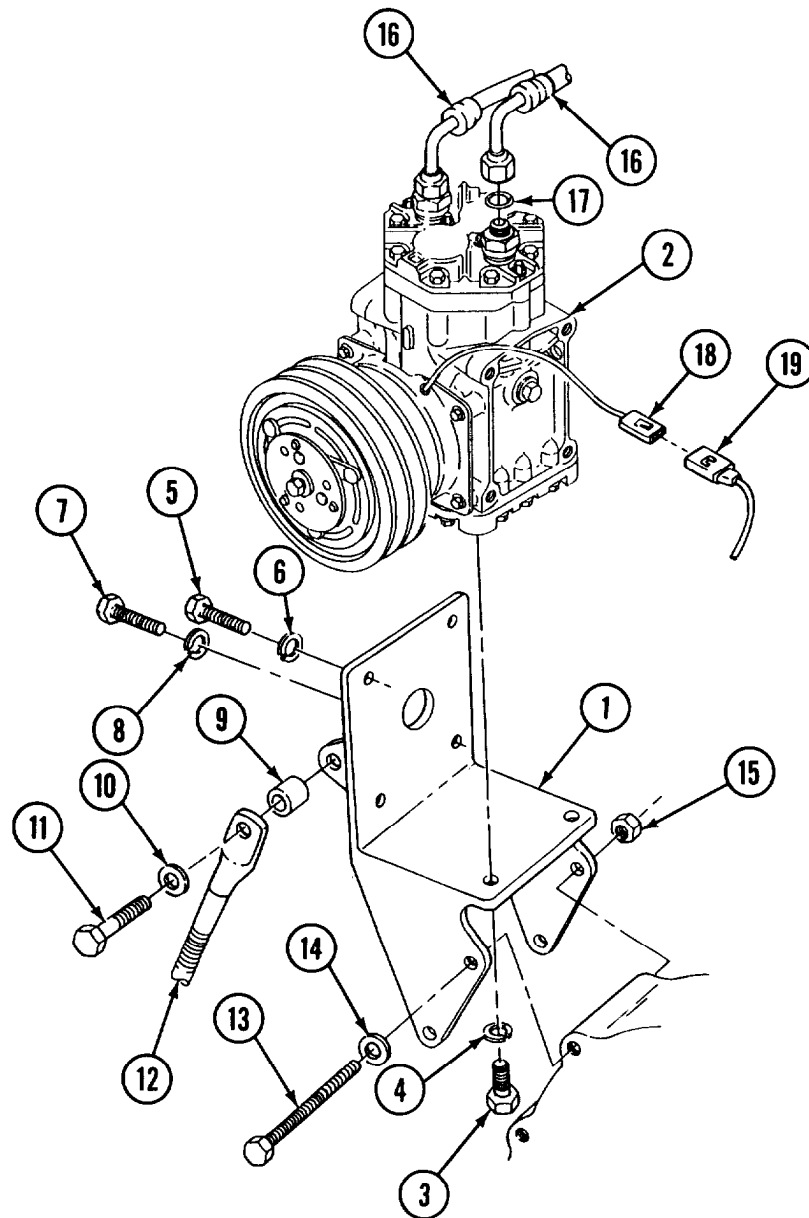

NOTE

Any time air conditioner system refrigerant is evacuated, replace receiver-drier.

- 11. REPLACE RECEIVER-DRIER (page 11.11-14).
- 12. SERVICE AIR CONDITIONER COMPRESSOR (page 11.1-23).

NOTE

Follow-on Maintenance:

- Install and adjust alternator belt (TM 9-2320-363-20).
- Charge and leak test air conditioning system (page 11.1-2 and TM 9-2320-363-20).
- Connect batteries (TM 9-2320-363-20).
- Check operation of air conditioning system (TM 9-2320-363-10).

AIR CONDITIONER RECEIVER-DRIER REPLACEMENT

This task covers: a. Removal b. Installation

INITIAL SETUP

Applicable Configuration:

All except M915A2 and M916A1

Tools and Special Equipment:

Tool Kit, SC 5180-90-CL-N26
Shop Equipment, SC 4910-95-CL-A31

Materials/Parts:

Packing, Preformed (2)	P/N 011C944-70
Cap and Plug Set	Appendix B, Item 7.1
Loctite	Appendix B, Item 33
Oil, Refrigerant	Appendix B, Item 43.1
Tags, Identification	Appendix B, Item 55

References:

TM 9-2320-363-10
TM 9-2320-363-20

Equipment Condition:

Reference	Condition Description
TM 9-2320-363-20	Batteries Disconnected
TM 9-2320-363-20	Binary Switch Removed
Page 11.1-2	Refrigerant Recovered
Page 11.1-21	Fan Cycling Switch Removed

General Safety Instructions:

WARNING

- Use care to prevent refrigerant from touching your skin or eyes, because liquid refrigerant, when exposed to air, quickly evaporates and will freeze skin or eye tissue. Serious injury or blindness could result if you come in contact with liquid refrigerant.
- Refrigerant R-134a air conditioning systems should not be pressure tested or leak tested with compressed air. Combustible mixtures of air and R-134a may form, resulting in a fire or explosion, which could cause personal injury.

REMOVAL

CAUTION

Water and dirt can damage the refrigerant system. Five minutes of not being capped is the limit for any hose or component. Do not blow shop air through the refrigerant hoses; shop air is wet (humid).

NOTE

The receiver-drier and moisture indicator are one unit and cannot be replaced separately.

NOTE

- If the desiccant cartridge inside the receiver-drier has fallen apart, evacuate the system and replace the expansion valve and the refrigerant compressor (desiccant matter can't be removed from these parts). A cartridge may fall apart from too much moisture in the system, because of poor evacuation of the system, or lack of maintenance.
 - Do not disconnect or connect refrigerant fittings using only one wrench. Hold one fitting in place using a wrench, and turn the other fitting with a second wrench.
1. TAG AND DISCONNECT REFRIGERANT LINES (1) FROM THE RECEIVER-DRIER (2). INSTALL PLUGS IN THE REFRIGERANT LINES. DISCARD PREFORMED PACKINGS.
 2. LOOSEN HOSE CLAMP (3) ATTACHING THE RECEIVER-DRIER (2) TO THE MOUNTING BRACKET AND REMOVE THE RECEIVER-DRIER.

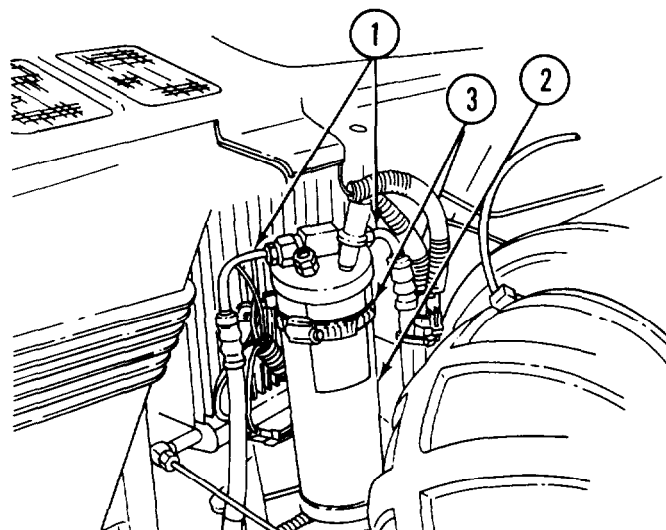
**INSTALLATION**

1. POSITION THE RECEIVER-DRIER (2) IN THE MOUNTING BRACKET. TIGHTEN THE HOSE CLAMP (3) SECURELY.
2. REMOVE THE PLUGS FROM THE REFRIGERANT LINES (1) AND THE LINE PORTS ON THE NEW RECEIVER-DRIER (2). INSTALL NEW PREFORMED PACKINGS AND APPLY REFRIGERANT OIL TO THEM. APPLY LOCTITE 2420 TO THE MALE FITTING THREADS AND CONNECT THE REFRIGERANT LINES TO THE RECEIVER-DRIER. USING TWO WRENCHES TO AVOID TWISTING THE TUBING, TIGHTEN THE CONNECTIONS TO THE VALVES IN TABLE D-3, APPENDIX D.
3. SERVICE AIR CONDITIONER COMPRESSOR (page 11 .1-23).

NOTE

Follow-on Maintenance:

- Install fan cycling switch (page 11 .1-21).
- Install binary switch (TM 9-2320-363-20).
- Connect batteries (TM 9-2320-363-20).
- Charge and leak test air conditioning system (page 11.1-2 and TM 9-2320-363-20).
- Check operation of air conditioning system (TM 9-2320-363-10).

AIR CONDITIONER CONDENSER REPLACEMENT

This task covers: a. Removal b. Installation

INITIAL SETUP

Applicable Configuration:

All except M915A2 and M916A1

Tools and Special Equipment:

Tool Kit, SC 5180-90-CL-N26
Shop Equipment, SC 4910-95CL-A31

Materials/Parts:

Packing, Preformed	P/N 011 C944-70
Packing, Preformed	P/N 0 1 X944-70
Receiver-Drier	P/IN 088335-00
Cap and Plug Set	Appendix B, Item 7.1
Loctite	Appendix B, Item 33
Oil, Refrigerant	Appendix B, Item 43.1
Tags, Identification	Appendix B, Item 55

References:

TM 9-2320-363-10
TM 9-2320-363-20

Equipment Condition:

Reference	Condition Description
Page 11.1-2	Refrigerant Recovered

General Safety Instructions:

WARNING

- Use care to prevent refrigerant from touching your skin or eyes, because liquid refrigerant, when exposed to air, quickly evaporates and will freeze skin or eye tissue. Serious injury or blindness could result if you come in contact with liquid refrigerant.
- Refrigerant R-134a air conditioning systems should not be pressure tested or leak tested with compressed air. Combustible mixtures of air and R-134a may form, resulting in a fire or explosion, which could cause personal injury.

REMOVAL

CAUTION

Water and dirt can damage the refrigerant system. Five minutes of not being capped is the limit for any hose or component. Do not blow shop air through the refrigerant hoses; shop air is wet (humid).

NOTE

Do not disconnect or connect refrigerant fittings using only one wrench. Hold one fitting in place using a wrench, and turn the other fitting with a second wrench.

1. TAG AND DISCONNECT THE REFRIGERANT LINES (1) AT THE CONDENSER (2). INSTALL PLUGS IN THE REFRIGERANT LINES AND THE CONDENSER PARTS. DISCARD PREFORMED PACKINGS.

2. REMOVE THE FASTENERS ATTACHING THE CONDENSER (2) TO THE RADIATOR, AND REMOVE THE CONDENSER.

INSTALLATIO

1. PLACE THE CONDENSER (2) ON THE RADIATOR. INSTALL AND TIGHTEN THE FASTENERS 108 LB-IN (1220 N.cm).

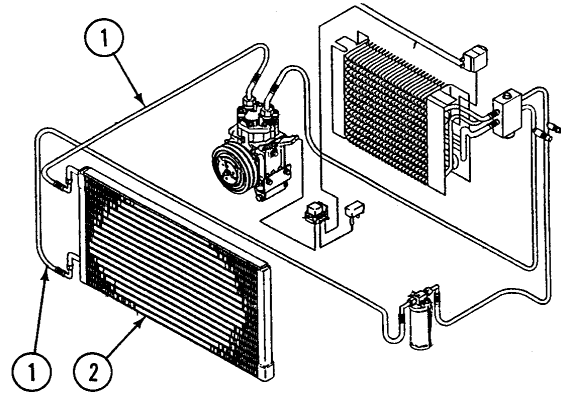

2. REMOVE THE PLUGS FROM THE REFRIGERANT LINES (1) AND THE CONDENSER (2). INSTALL NEW PREFORMED PACKINGS AND APPLY REFRIGERANT OIL TO THEM. APPLY LOCTITE 242® TO THE MALE FITTING THREADS AND CONNECT THE REFRIGERANT LINES TO THE CONDENSER. USING TWO WRENCHES TO AVOID TWISTING THE TUBING, TIGHTEN THE CONNECTIONS TO THE VALUES IN TABLE D-3, APPENDIX D.

NOTE

Any time air conditioning system refrigerant is evacuated, replace receiver-drier.

3. REPLACE RECEIVER-DRIER (page 11.1-14).
4. SERVICE AIR CONDITIONER COMPRESSOR (page 11.1-23).

NOTE

Follow-on Maintenance:

Charge and leak test air conditioning system (page 11.1-2 and TM 9-2320-363-20).
 Check operation of air conditioning system (TM 9-2320-363-10).

AIR CONDITIONER HOSE REPLACEMENT

This task covers: a. Removal b. Installation

INITIAL SETUP

Applicable Configuration:

All except M915A2 and M916A1

Tools and Special Equipment:

Tool Kit, SC 5180-90-CL-N26
Shop Equipment, SC 4910-95-CL-A31
Leak Detector, 16500
Recovery and Recycling System, 34400

Materials/Parts:

Gasket	P/N 22-46774-000
Packing, Preformed	(As Required)
Receiver-Drier	P/N 088335-00
Cap and Plug Set	Appendix B, Item 7.1
Caulk, Strip	Appendix B, Item 7.2
Loctite 242	Appendix B, Item 33
Oil, Refrigerant	Appendix B, Item 43.1
Tape, Insulation	Appendix B, Item 57.1

References:

TM 9-2320-363-10
TM 9-2320-363-20

Equipment Condition:

Reference	Condition Description
TM 9-2320-363-20 Page 11.1-2	Batteries Disconnected Refrigerant Recovered

General Safety Instructions:

WARNING

- Use care to prevent refrigerant from touching your skin or eyes, because liquid refrigerant, when exposed to air, quickly evaporates and will freeze skin or eye tissue. Serious injury or blindness could result if you come in contact with liquid refrigerant.
- Refrigerant R-134a air conditioning systems should not be pressure tested or leak tested with compressed air. Combustible mixtures of air and R-134a may form, resulting in a fire or explosion, which could cause personal injury.

REMOVAL

WARNING

Use care to prevent refrigerant from touching your skin or eyes, because liquid refrigerant, when exposed to air, quickly evaporates and will freeze skin or eye tissue. Serious injury or blindness could result if you come in contact with liquid refrigerant.

1. THE FOLLOWING AIR CONDITIONING SYSTEM HOSES CAN BE REPLACED:
 - a. COMPRESSOR-TO-TUBE ASSEMBLY (ON FIREWALL)
 - b. COMPRESSOR-TO-CONDENSER
 - c. RECEIVER-DRIER-TO-TUBE ASSEMBLY (ON FIREWALL)
 - d. RECEIVER-DRIER-TO-EXPANSION VALVE
 - e. TUBE ASSEMBLY (ON FIREWALL)-TO-EXPANSION VALVE (2 PLACES)

2. REMOVE INSULATING TAPE FROM EACH HOSE CONNECTION.

NOTE

Do not disconnect or connect refrigerant fittings using only one wrench. Hold one fitting in place using a wrench, and turn the other fitting with a second wrench.

3. DISCONNECT EACH END OF HOSE CONNECTION.

CAUTION

Water and dirt can damage the refrigerant system. Five minutes of not being capped is the limit for any hose or component. Do not blow shop air through the refrigerant hoses; shop air is wet (humid).

4. CAP EACH OPENING WHERE HOSE WAS DISCONNECTED.
5. DISCARD PREFORMED PACKINGS (1).
- 5.5 AT FIREWALL, REMOVE TWO SCREWS (4), TWO WASHERS (5), TUBE ASSEMBLY (3), AND GASKET (2).

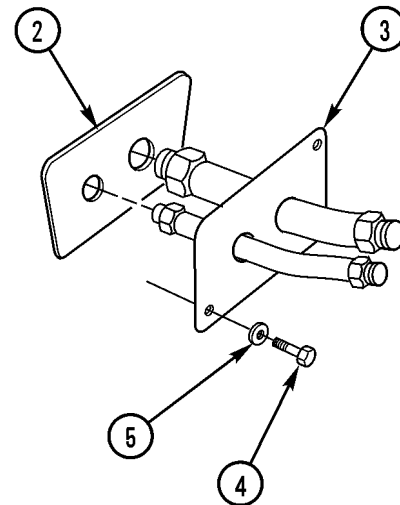

INSTALLATION

- 0.1 INSTALL GASKET (2) ON TUBE ASSEMBLY (3) AND TUBE ASSEMBLY ON FIREWALL.
- 0.2 INSTALL TWO WASHERS (5) AND TWO SCREWS (4).
1. INSTALL NEW PREFORMED PACKINGS (1) AND LUBRICATE THEM WITH REFRIGERANT OIL.
2. APPLY LOCTITE TO MALE FITTING THREADS (6) AND CONNECT EACH END OF HOSE.
3. TORQUE CONNECTIONS (Table D-3, Appendix D).
4. APPLY INSULATING TAPE AT EACH HOSE CONNECTION.
5. WRAP REMAINDER OF HOSE WITH STRIP CAULK.

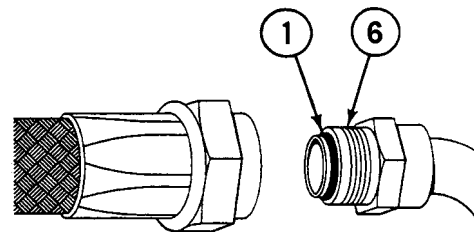

AIR CONDITIONER HOSE REPLACEMENT (CONT)

NOTE

Any time air conditioning system refrigerant is evacuated, replace receiver-drier.

6. REPLACE RECEIVER-DRIER (page 11.1-14).
7. SERVICE AIR CONDITIONER COMPRESSOR (page 11.1-23).

WARNING

Refrigerant R-134a air conditioning systems should not be pressure tested or leak tested with compressed air. Combustible mixtures of air and R-134a may form, resulting in fire or explosion, which could cause personal injury.

8. CHARGE SYSTEM WITH REFRIGERANT (page 11.1-2). LEAK TEST AIR CONDITIONING SYSTEM (TM 9-2320-363-20).

NOTE

Follow-on Maintenance:

Connect batteries (TM 9-2320-363-20).

Check operation of air conditioning system (TM 9-2320-363-10).

AIR CONDITIONER FAN CYCLING SWITCH REPLACEMENT

This task covers: a. Removal b. Installation

INITIAL SETUP

Applicable Configuration:

All except M915A2 and M916A1

Tools and Special Equipment:

Tool Kit, SC 5180-90-CL-N26
Shop Equipment, SC 4910-95-CL-A31
Recovery and Recycling System, 34400

Materials/Parts:

Packing, Preformed P/N 011C944-70
Oil, Refrigerant Appendix B, Item 43.1

References:

TM 9-2320-363-10
TM 9-2320-363-20

Equipment Condition:

Reference	Condition Description
TM 9-2320-363-20	Batteries Disconnected

General Safety Instructions:

WARNING

Use care to prevent refrigerant from touching your skin or eyes, because liquid refrigerant, when exposed to air, quickly evaporates and will freeze skin or eye tissue. Serious injury or blindness could result if you come in contact with liquid refrigerant.

REMOVAL

1. DISCONNECT HARNESS CONNECTOR (1) FROM FAN CYCLING SWITCH (2).
2. UNSCREW FAN CYCLING SWITCH (2) FROM COUPLING (3) ON RECEIVER-DRIER (4). DISCARD PREFORMED PACKING.

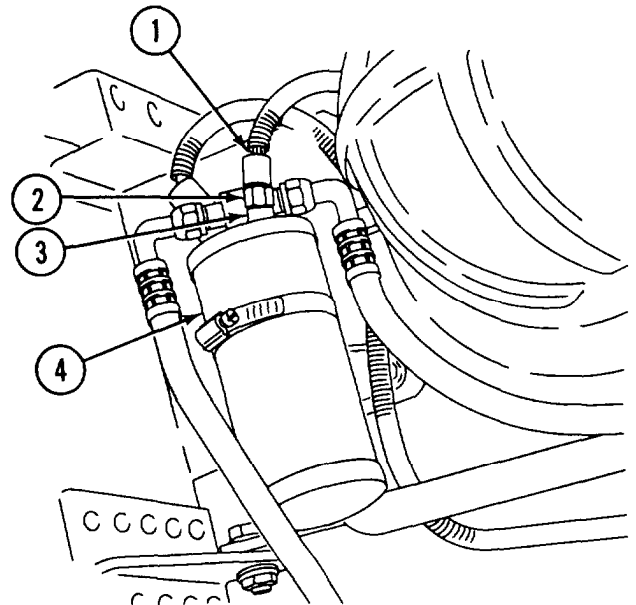

AIR CONDITIONER FAN CYCLING SWITCH REPLACEMENT (CONT)

INSTALLATION

1. LUBRICATE A NEW PREFORMED PACKING WITH REFRIGERANT OIL AND INSTALL IT OVER MALE THREADS OF COUPLING (1) ON RECEIVER-DRIER (2).
2. SCREW FAN CYCLING SWITCH (3) INTO COUPLING (1) ON RECEIVER-DRIER (2).
3. CONNECT HARNESS CONNECTOR (4) TO FAN CYCLING SWITCH (3).

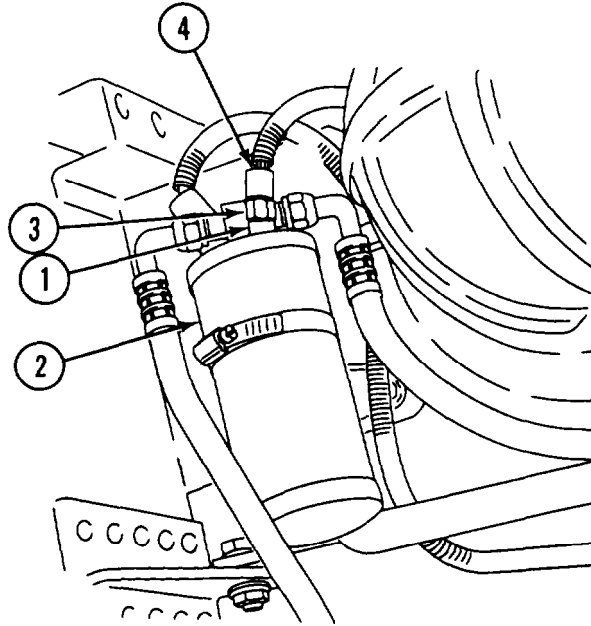

4. CHECK REFRIGERANT SYSTEM CHARGE AND CHARGE SYSTEM AS REQUIRED (page 11.1-2).

NOTE

Follow-on Maintenance:

Connect batteries (TM 9-2320-363-20).

Check operation of air conditioning system (TM 9-2320-363-10).

AIR CONDITIONER COMPRESSOR SERVICE

This task covers: a. General Information b. Service

INITIAL SETUP

Applicable Configuration:

All except M915A2 and M916A1

Tools and Special Equipment:

Tool Kit, SC 5180-90-CL-N26
Shop Equipment, SC 4910-95-CL-A31
Gage, Oil Level. 99-431

Materials/Parts:

Oil, Refrigerant Appendix B, Item 43.1

References:

TM 9-2320-363-20

Equipment Condition:

Reference	Condition Description
TM 9-2320-363-20	Batteries Disconnected
Page 11.1-2	Refrigerant Recovered

General Safety Instructions:

WARNING

Do not remove air conditioner compressor oil fill plug without first recovering the system. Failure to recover the system could cause uncontrolled release of high-pressure refrigerant, which can freeze skin and eye tissue causing serious injury or blindness.

GENERAL INFORMATION

CAUTION

- Always use the correct refrigerant oil in R-134a air conditioning system. Never mix oils. If the wrong oil is used, or if oils are mixed, the compressor could seize due to improper lubrication.
- Refrigerant oil must be from a container that has not been opened or that has been tightly sealed since its last use. Tubing, funnels, or other equipment used to transfer refrigerant oil should be very clean and dry. Failure to follow this caution may result in contamination of system.

NOTE

Replacing only the amount of refrigerant oil that was removed during evacuation may result in the wrong oil charge; oil charge may have been incorrect prior to evacuation. The only way to ensure proper oil charge is to check the oil level in the compressor with an oil level gage.

AIR CONDITIONER COMPRESSOR SERVICE (CONT)

1. WHEN HANDLING REFRIGERANT OIL:
 - a. OIL SHOULD BE FREE OF WATER, DUST, METAL POWDER, AND OTHER FOREIGN SUBSTANCES.
 - b. DO NOT MIX REFRIGERANT OIL WITH OTHER TYPES OR VISCOSITIES OF OIL
 - c. QUICKLY SEAL OIL CONTAINER AFTER USE. REFRIGERANT OIL ABSORBS MOISTURE WHEN EXPOSED TO AIR FOR ANY PERIOD.
2. AIR CONDITIONING SYSTEM SHOULD HAVE ABOUT 14 fl oz (414 ml) OF REFRIGERANT OIL. THERE SHOULD BE 10 fl oz (296 ml) IN THE COMPRESSOR.
3. EACH MAJOR COMPONENT HAS ABOUT 2 fl oz (59 ml) OF REFRIGERANT OIL. THEREFORE, ADDITIONAL OIL MUST BE ADDED TO THE COMPRESSOR WHEN A MAJOR COMPONENT IS REPLACED.

EXAMPLE: IF THE CONDENSER AND RECEIVER-DRIER ARE TO BE REPLACED, FIRST CHECK OIL LEVEL IN COMPRESSOR. COMPRESSOR SHOULD HAVE 10 fl oz (296 ml). ADD OIL IF NEEDED. THEN, AFTER REPLACING CONDENSER AND RECEIVER-DRIER, ADD AN ADDITIONAL 4 fl oz (118 ml) OF OIL TO THE COMPRESSOR. THE ENTIRE SYSTEM SHOULD THEN HAVE ABOUT 14 fl oz (414 ml).

SERVICE

WARNING

Do not remove air conditioner compressor oil fill plug without first recovering the system. Failure to recover the system could cause uncontrolled release of high-pressure refrigerant, which can freeze skin and eye tissue causing serious injury or blindness.

1. REMOVE OIL FILL PLUG (1) AND PREFORMED PACKING FROM COMPRESSOR (2). RETAIN PREFORMED PACKING IF NOT DAMAGED. OR IF THERE ARE NO SIGNS OF LEAKS.
2. USE OIL LEVEL GAGE TO CHECK OIL LEVEL IN COMPRESSOR (2):
 - a. IF GAGE BOTTOMS OUT BEFORE GOING IN MORE THAN 3 IN. (7.6 CM), IT IS HITTING COMPRESSOR CRANKSHAFT. ROTATE DRIVE PLATE BY HAND AND INSERT GAGE AGAIN UNTIL IT CONTACTS BOTTOM OF SUMP.
 - b. USE THE FOLLOWING TABLE TO DETERMINE OIL QUANTITY IN COMPRESSOR (2).

**Oil Level Gage Depth
In Inches (mm)**

7/8 in. (22.2 mm)
 1 in. (25.4 mm)
 1 1/8 in. (28.6 mm)
 1 7/16 in. (36.5 mm)
 1 1/16 in. (43 mm)

**Oil Quantity
In Fluid Oz (ml)**

6 fl oz (177 ml)
 8 fl oz (237 ml)
 10 fl oz (296 ml)
 12 fl oz (355 ml)
 14 fl oz (414 ml)

3. ADD OR REMOVE OIL FROM COMPRESSOR (2) SO THAT OIL CHARGE IN COMPRESSOR IS 10 fl oz (296 ml).
4. ADD ADDITIONAL OIL TO COMPRESSOR (2) BASED ON NUMBER OF MAJOR AIR CONDITIONING COMPONENTS REPLACED. TOTAL CHARGE SHOULD BE 14 fl oz (414 ml)
5. ENSURE THAT PREFORMED PACKING AND THREADS OF OIL FILL PLUG (1) ARE CLEAN. BEING CAREFUL NOT TO TWIST PREFORMED PACKING, INSTALL OVER THREADS OF OIL FILL PLUG. INSTALL OIL FILL PLUG AND TIGHTEN SNUGLY.

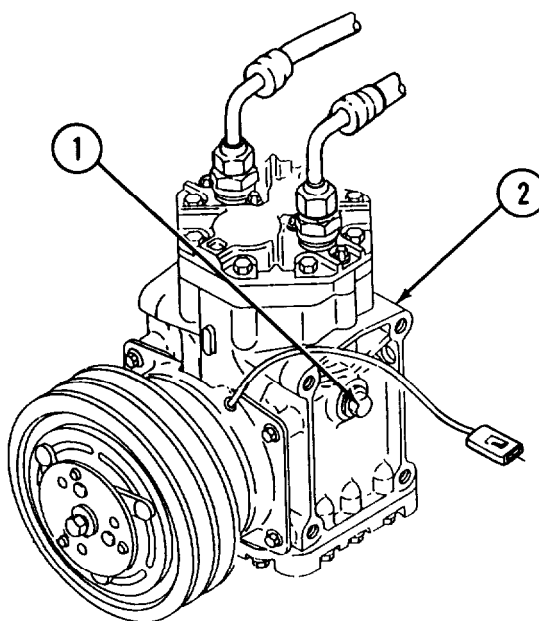

NOTE

Follow-on Maintenance:

Charge and leak test air conditioning system (page 11.1-2 and TM 9- 2320- 363- 20) .

INDEX

<i>Subject</i>	<i>Page</i>
A	
Accessory Drive Replacement	3-126
Adapter, Front Engine Mount, Replacement	3-46
Adapter, Winch Hydraulic Oil Filter, Replacement (M916A1 and M916A2)	11-39
Air Compressor Drive Replacement and Repair	3-92
Air Conditioner Compressor Replacement (All Except M915A2 and M916A1)	11.1-9
Air Conditioner Compressor Service (All Except M915A2 and M916A1)	11.1-23
Air Conditioner Condenser Replacement (All Except M915A2 and M916A1)	11.1-16
Air Conditioner Fan Cycling Switch Replacement (All Except M915A2 and M916A1)	11.1-21
Air Conditioner Receiver-Drier Replacement (All Except M915A2 and M916A1)	11.1-14
Air Conditioner Hose Replacement (All Except M915A2 and M916A1)	11.1-18
Air Conditioning System Refrigerant (R-134a) Maintenance (All Except M915A2 and M916A1)	11.1-2
Air Conditioning System Troubleshooting and Testing (All Except M915A2 and M916A1)	2-28.1
Air Ducts Replacement	
All Except M915A2 and M916A1	10-39.0
M915A2 and M916A1	10-36
Air Intake Manifold Replacement	
All Except M915A2 and M916A1	3-66.1
M915A2 and M916A1	3-61
Air Shift Chamber Replacement (All Except M915A2)	3-270
Arm Assemblies, Rocker, Replacement	3-183
Axle Assembly, Front, Replacement (M915A2)	5-40
Axle, Front, Replacement (All Except M915A2)	5-2
Axle, Rear, Replacement	
All Except M915A2	6-22
M915A2	6-16
B	
Ball, Bushing, and Oil Seal, Front, Replacement (All Except M915A2)	5-30
Ball Socket, Front, Replacement (All Except M915A2)	5-15
Beam, Equalizing, Replacement	
All Except M915A2	9-28
M915A2	9-22
Bearings and Camshaft Replacement	3-162
Breather Tube Replacement	3-78
C	
Cab Alligator Crossmember Replacement	
All Except M915A2	8-37
M915A2	8-28
Cab Anti-Lock Brake System (ABS) Wiring Harness Replacement (M915A2)	4-42
Cab Anti-Lock Brake System (ABS) Wiring Harness Replacement (M916A2 and M917A1)	4-43.0
Cab Door Replacement	10-89
Cab Floor Anti-Lock Brake System (ABS) Wiring Harness Replacement (M915A2 and M916A1)	4-38
Cab Mounts, Front, Replacement	10-40
Cab Mounts, Rear, Replacement	10-49

INDEX (CONT)

<i>Subject</i>	<i>Page</i>
C (Cont)	
Cab Replacement	
All Except M915A2	10-75
M915A2	10-64
Camshaft and Bearings Replacement	3-162
Carrier, Forward-Rear Axle Differential, Replacement	6-2
Case, Transfer, Mounts, Replacement (All Except M915A2)	3-269.0
Case, Transfer, Replacement (All Except M915A2)	3-263
Caster, Front Axle, Adjustment (M915A2)	5-60
Chassis Wiring Harness Replacement	4-6
Cleaning Instructions, General	2-30
Common Tools and Equipment	2-1
Compressor, Air Conditioner, Replacement (All Except M915A2 and M916A1)	11.1-9
Compressor, Air Conditioner, Service (All Except M915A2 and M916A1)	11.1-23
Compressor, Drive, Air, Replacement and Repair	3-92
Condenser, Air Conditioner, Replacement (All Except M915A2 and M916A1)	11.1-16
Counterbalance Valve Replacement and Repair (M916A1 and M916A2)	11-20
Cover and Pad, Seat, Repair	10-2
Cover, Gear Case, Replacement	3-116
Cover, Rocker, Replacement	3-71
Crankshaft Front Oil Seal Replacement	3-227
Crankshaft Oversize Front Oil Seal Replacement	3-231
Crankshaft Oversize Rear Oil Seal Replacement	3-145
Crankshaft Rear Oil Seal Replacement	3-141
Cross Tube Arm, Front, Replacement	5-58
Crossmember Assembly, Rear, Replacement	
All Except M915A2	8-20
M915A2	8-15
Crossmember, Cab Alligator, Replacement	
All Except M915A2	8-37
M915A2	8-28
Crossmember, Front, Replacement	8-10
Crossmember, Midships Alligator, Replacement	
All Except M915A2	8-54
M915A2	8-46
Crossmember, Overslung, Replacement	8-25
Crossmember, Rear Suspension, Replacement	
All Except M915A2	8-67
M915A2	8-62
CTIS Wiring Harness Replacement (M917A1 and M917A1 w/MCS)	4-47.4
Cylinder Head Replacement	3-80
D	
Damper, Vibration, Replacement	3-122
Dashboard Replacement	10-3
Destruction of Army Materiel to Prevent Enemy Use	1-1
Differential Carrier, Front, Replacement (All Except M915A2)	5-34
Differential Carrier, Rear-Rear Axle, Replacement	6-12

INDEX (CONT)

<i>Subject</i>	<i>Page</i>
D (Cont)	
Direction Control Valve Replacement (M916A1 and M916A2)	11-30
Ducts, Air, Replacement	
All Except M915A2 and M916A1	10-39.0
M915A2 and M916A1	10-36
E	
Electronic Control Module Wiring Harness Replacement	4-16
Element, Internal Filter, Replacement	3-258
Engine Power Wiring Harness Replacement	4-18
Engine Replacement	3-4
Engine Retarder Replacement and Repair	3-129
Engine Retarder Solenoid Test and Replacement	4-50
Engine Wiring Harness Replacement	4-8
Equalizing Beam Replacement	
All except M915A2	9-28
M915A2	9-22
Equipment Description and Data	
Characteristics, Capabilities, and Features	1-3
Differences Between Models	1-3
Location and Description of Components	1-3
Exhaust Manifold Replacement	
All Except M915A2 and M916A1	3-70.1
M915A2 and M916A1	3-67
F	
Fan Cycling Switch, Air Conditioner, Replacement (All Except M915A2 and M916A1)	11.1-21
Fan Drive Support Replacement	3-56
Flex Plate Replacement and Repair	3-154
Flywheel Housing Replacement	3-148
Forms and Records, Maintenance	1-1
Forward-Rear Axle Differential Carrier Replacement	6-2
Frame, Hydraulic Winch, Replacement (M916A1 and M916A2)	11-34
Frame Rail Extension and Reinforcement Replacement	8-2
Front Anti-Lock Brake System (ABS) Wiring Harness Replacement (M915A2 and M916A1)	4-44
Front Anti-Lock Brake System (ABS) Wiring Harness Replacement (M916A2 and M917A1)	4-45.2
Front Axle Assembly Replacement (M915A2)	5-40
Front Axle Caster Adjustment (M915A2)	5-60
Front Axle Replacement (All Except M915A2)	5-2
Front Axle Shaft Replacement and Repair (All Except M915A2)	5-7
Front Ball, Bushing, and Oil Seal Replacement (All Except M915A2)	5-30
Front Ball Socket Replacement (All Except M915A2)	5-15
Front Cab Mounts Replacement	10-40
Front Cross Tube Arm Replacement	5-58
Front Crossmember Replacement	8-10
Front Differential Carrier Replacement (All Except M915A2)	5-34
Front Engine Mount Adapter Replacement	3-46

INDEX (CONT)

<i>Subject</i>	<i>Page</i>
F (Cont)	
Front Engine Mount Support Replacement	8-7
Front Spring Hangers Replacement	9-8
Front Spring Replacement	9-2
Front Steering Arm Replacement (M915A2)	5-56
Front Steering Knuckle Replacement and Repair (M915A2)	5-44
Front Yoke and Oil Seal Replacement (All Except M915A2)	5-38
G	
Gear Case Cover Replacement	3-116
Gear, Steering, Replacement	7-4
General Assembly Instructions	2-34
General Cleaning Instructions	2-30
General Disassembly Instructions	2-29
General Information	1-1
General Inspection Instructions	2-32
General Installation Instructions	2-35
General Lubrication Instructions	2-36
General Maintenance Instructions	2-29
General Removal Instructions	2-29
General Repair Instructions	2-33
General Torque Value Instructions	2-36
Governor Service and Replacement	3-260
H	
Hanger, Rear Spring, Replacement	9-18
Hangers, Front Spring, Replacement	9-8
Head, Cylinder, Replacement	3-80
Hose, Air Conditioner, Replacement (All Except M915A2 and M916A1)	11.1-18
Housing, Flywheel, Replacement	3-148
Hydraulic Motor Replacement (M916A1 and M916A2)	11-15
Hydraulic Pump Replacement (M916A1 and M916A2)	11-2
Hydraulic Winch Frame Replacement (M916A1 and M916A2)	11-34
Hydraulic Winch Replacement (M916A1 and M916A2)	11-9
I	
Injector Replacement	3-108
Injector Solenoid Repair	3-114
Injector Wiring Harness Replacement	4-2
Inspection Instructions, General	2-32
Internal Filter Element Replacement	3-258

INDEX (CONT)

<i>Subject</i>	<i>Page</i>
L	
Lockup Cutoff Control Valve Replacement	3-262
Lubrication Instructions, General	2-36
Lubrication Pump Replacement (All Except M915A2)	3-276
M	
Main Cab Wiring Harness Replacement	4-22
Maintenance Forms, Records and Reports	1-1
Manifold, Air Intake, Replacement	
All Except M915A2 and M916A1	3-66.1
M915A2 and M916A1	3-61
Manifold, Exhaust, Replacement	
All Except M915A2 and M916A1	3-70.1
M915A2 and M916A1	3-67
Material Control System (MCS) Chassis Wiring Harness Replacement (M917A1 w/MCS)	4-47.2
Metric System	1-2
Midships Alligator Crossmember Replacement	
All Except M915A2	8-54
M915A2	8-46
Modulator Valve Replacement	3-261
Motor, Hydraulic, Replacement (M916A1 and M916A2)	11-15
Mounts, Front Cab, Replacement	10-40
Mounts, Rear Cab, Replacement	10-49
Mounts, Rear Engine, Replacement	
All Except M915A2	3-52
M915A2	3-48
Mounts, Transfer Case, Replacement (All Except M915A2)	3-269.0
O	
Oil Pan Replacement	3-220
Oil Pump Replacement and Repair	3-199
Oil Relief Valve and Oil Regulator Valve Replacement	3-216
Output Shaft Replacement and Repair	6-7
Overhead Cab Wiring Harness Replacement	4-36
Overslung Crossmember Replacement	8-25
P	
Pan, Oil, Replacement	3-220
Plate, Flex, Replacement and Repair	3-154
Power Steering Pump Replacement	7-2
Power Take-Off (PTO) Replacement (All Except M915A2)	11-42
Power Take-Off (PTO) Wiring Harness Replacement (All Except M915A2)	4-47.6
Preliminary Troubleshooting Procedures	2-2
Preparation for Storage and Shipment	1-1
Principles of Operation	1-3

INDEX (CONT)

<i>Subject</i>	<i>Page</i>
P (Cont)	
Pump, Hydraulic, Replacement (M916A1 and M916A2)	11-2
Pump, Lubrication, Replacement (All Except M915A2)	3-276
Pump, Oil, Replacement and Repair	3-199
Pump, Power Steering, Replacement	7-2
R	
Rail Extension and Reinforcement, Frame, Replacement	8-2
Rear Anti-Lock Brake System (ABS) Wiring Harness Replacement (M915A2 and M916A1)	4-46
Rear Anti-Lock Brake System (ABS) Wiring Harness Replacement (M916A2 and M917A1)	4-45.4
Rear Axle Replacement	
All Except M915A2	6-22
M915A2	6-16
Rear Cab Mounts Replacement	10-49
Rear Crossmember Assembly Replacement	
All Except M915A2	8-20
M915A2	8-15
Rear Engine Mounts Replacement	
All Except M915A2	3-52
M915A2	3-48
Rear-Rear Axle Differential Carrier Replacement	6-12
Rear Spring and Saddle Assembly Replacement	9-12
Rear Spring Hanger Replacement	9-18
Rear Suspension Crossmember Replacement	
All Except M915A2	8-67
M915A2	8-62
Rear Window Replacement	10-84
Rear Yoke and Oil Seal Replacement	
All Except M915A2	6-30
M915A2	6-28
Receiver-Drier, Air Conditioner, Replacement (All Except M915A2 and M916A1)	11.1-14
Refrigerant (R-134a), Air Conditioning System, Maintenance (All Except M915A2 and M916A1)	11.1-2
Regulator Valve, Oil, Replacement	3-216
Relief Valve, Oil, Replacement	3-216
Relieving Hydraulic System Pressure (M916A1 and M916A2)	2-2
Repair Instructions, General	2-33
Repair Parts	2-1
Reporting Equipment Improvement Recommendations (EIRs)	1-2
Reports	1-1
Retarder, Engine, Replacement and Repair	3-129
Retarder, Solenoid, Engine, Test and Replacement	4-50
Rocker Arm Assemblies Replacement	3-183
Rocker Cover Replacement	3-71
Rod, Tie, Replacement and Repair	5-52
Rod, Torque, Replacement	9-14

INDEX (CONT)

<i>Subject</i>	<i>Page</i>
S	
Seal, Crankshaft Front Oil, Replacement	3-227
Seal, Crankshaft Oversize Front Oil, Replacement	3-231
Seal, Crankshaft Oversize Rear Oil, Replacement	3-145
Seal, Crankshaft Rear Oil, Replacement	3-141
Seat Cover and Pad Repair	10-2
Service, Air Conditioner Compressor (All Except M915A2 and M916A1)	11.1-23
Shaft, Front Axle, Replacement (All Except M915A2)	5-7
Shaft, Output, Replacement and Repair	6-7
Shift Chamber, Air, Replacement (All Except M915A2)	3-270
Solenoid, Injector, Repair	3-114
Solenoid, Starter, Replacement	4-48
Special Tools, TMDE, and Support Equipment	2-1
Speed Control Valve Replacement (M916A1 and M916A2)	11-26
Spring and Saddle Assembly, Rear, Replacement	9-12
Spring, Front, Replacement	9-2
Stall, Test, Transmission	2-3
Starter Solenoid Replacement	4-48
STE-ICE Wiring Harness Replacement	4-20
Steering Arm, Front, Replacement (M915A2)	5-56
Steering Gear Replacement	7-4
Steering Knuckle, Front, Replacement and Repair (M915A2)	5-44
Support Equipment, Special Tools and TMDE	2-1
Support, Fan Drive, Replacement	3-56
Support, Front Engine Mount, Replacement	8-7
Switch Panel Wiring Harness Replacement	4-40
T	
Tie Rod Replacement and Repair	5-52
Tools and Equipment, Common	2-1
Torque Rod Replacement	9-14
Torque Value Instructions, General	2-36
Transfer Case Mounts Replacement (All Except M915A2)	3-269.0
Transfer Case Replacement (All Except M915A2)	3-263
Transfer Case Yoke and Oil Seal Replacement (All Except M915A2)	3-274
Transmission Output Yoke Replacement and Repair	3-256
Transmission Replacement	3-235
Transmission Stall Test	2-3
Troubleshooting	
Air Conditioner (All Except M915A2 and M916A1)	2-28.1
Arctic Heater	2-26
Engine	2-6
Hydraulic Winch (M916A1 and M916A2)	2-24
Steering	2-20
Transmission	2-8
Troubleshooting Procedures, Preliminary	2-2

INDEX (CONT)

<i>Subject</i>	<i>Page</i>
T (Cont)	
Tube, Breather, Replacement	3-78
Turbocharger Replacement	3-101
Turn Signal (Thru-Deck) Wiring Harness Replacement	4-14
Turn Signal/Marker Light Wiring Harness Replacement	4-12
V	
Valve, Counterbalance, Replacement and Repair (M916A1 and M916A2)	11-20
Valve, Direction Control, Replacement (M916A1 and M916A2)	11-30
Valve, Lockup Cutoff Control, Replacement	3-262
Valve, Modulator, Replacement	3-261
Valve, Speed Control, Replacement (M916A1 and M916A2)	11-26
Vibration, Damper, Replacement	3-122
W	
Warranty Information	1-2
Winch, Hydraulic, Oil Filter Adapter Replacement (M916A1 and M916A2)	11-39
Winch, Hydraulic, Replacement (M916A1 and M916A2)	11-9
Window, Rear, Replacement	10-84
Windshield Replacement	10-52
Wiring Harness, Cab Anti-Lock Brake System (ABS), Replacement (M915A2)	4-42
Wiring Harness, Cab Floor, Anti-Lock Brake System (ABS), Replacement (M915A2 and M916A1) ..	4-38
Wiring Harness, Cab Floor, Anti-Lock Brake System (ABS), Replacement (M916A2 and M917A1) ..	4-43.0
Wiring Harness, Chassis, Replacement	4-6
Wiring Harness, CTIS, Replacement (M917A1 and M917A1 w/MCS)	4-47.4
Wiring Harness, Electronic Control Module, Replacement	4-16
Wiring Harness, Engine Power, Replacement	4-18
Wiring Harness, Engine, Replacement	4-8
Wiring Harness, Front Anti-Lock Brake System (ABS), Replacement (M915A2 and M916A1)	4-44
Wiring Harness, Front Anti-Lock Brake System (ABS), Replacement (M916A2 and M917A1)	4-45.2
Wiring Harness, Injector, Replacement	4-2
Wiring Harness, Main Cab, Replacement	4-22
Wiring Harness, Material Control System (MCS), Chassis, Replacement (M917A1 w/MCS)	4-47.2
Wiring Harness, Overhead Cab, Replacement	4-36
Wiring Harness, Power Take-Off (PTO), Replacement (All Except M915A2)	4-47.6
Wiring Harness, Rear Anti-Lock Brake System (ABS), Replacement (M915A2 and M916A1)	4-46
Wiring Harness, Rear Anti-Lock Brake System (ABS), Replacement (M916A2 and M917A1)	4-45.4
Wiring Harness, STE/ICE, Replacement	4-20
Wiring Harness, Switch Panel, Replacement	4-40
Wiring Harness, Turn Signal (Thru-Deck), Replacement	4-14
Wiring Harness, Turn Signal/Marker Light, Replacement	4-12
Y	
Yoke, Transmission Output, Replacement and Repair	3-256
Yoke and Oil Seal, Front, Replacement (All Except M915A2)	5-38
Yoke and Oil Seal, Rear, Replacement	
All Except M915A2	6-30
M915A2	6-28
Yoke and Oil Seal, Transfer Case, Replacement (All Except M915A2)	3-274

By Order of the Secretary of the Army:

Official:

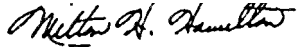

MILTON H. HAMILTON
*Administrative Assistant to the
Secretary of the Army*
01658

GORDON R. SULLIVAN
*General, United States Army
Chief of Staff*

Distribution:

To be distributed in accordance with DA Form 12-36-E (Block 0905) Direct Support and General Support maintenance requirements for TM9-2320-363-34-1.

RECOMMENDED CHANGES TO PUBLICATIONS AND BLANK FORMS						Use Part II (reverse) for Repair Parts and Special Tool Lists (RPSTL) and Supply Catalogs/Supply Manuals (SC/SM).	DATE Date you filled out this form.
For use of this form, see AR 25-30; the proponent agency is ODISC4.							
TO: (Forward to proponent of publication or form) (Include ZIP Code) AMSTALC-LPIT / TECH PUBS, TACOM-RI 1 Rock Island Arsenal Rock Island, IL 61299-7630						FROM: (Activity and location) (Include ZIP Code) Your mailing address	
PART I – ALL PUBLICATIONS (EXCEPT RPSTL AND SC/SM) AND BLANK FORMS							
PUBLICATION/FORM NUMBER TM 9-2320-363-34-1				DATE 16 June 1992	TITLE Truck, Tractor, M915A2, M916A1, M916A2, M917A1, M917A1 W/MCS Volume 1 of 2		
ITEM NO.	PAGE NO.	PARA-GRAPH	LINE NO. *	FIGURE NO.	TABLE NO.	RECOMMENDED CHANGES AND REASON (Provide exact wording of recommended changes, if possible).	
	0004 00-2	4-7				Wrong POC is listed. <div style="text-align: center; border: 1px solid black; padding: 20px;"></div>	
<i>*Reference to line numbers within the paragraph or subparagraph.</i>							
TYPED NAME, GRADE OR TITLE Your Name				TELEPHONE EXCHANGE/AUTOVON, PLUS EXTENSION		SIGNATURE Your Signature	

TO: <i>(Forward direct to addressee listed in publication)</i> AMSTALC-LPIT / TECH PUBS, TACOM-RI 1 Rock Island Arsenal Rock Island, IL 61299-7630	FROM: <i>(Activity and location) (Include ZIP Code)</i> Your address	DATE Date you filled out this form
--	--	--

PART II – REPAIR PARTS AND SPECIAL TOOL LISTS AND SUPPLY CATALOGS/SUPPLY MANUALS

PUBLICATION NUMBER TM 9-2320-363-34-1	DATE 16 June 1992	TITLE Truck, Tractor, M915A2, M916A1, M916A2, M917A1, M917A1 W/MCS Volume 1 of 2
--	----------------------	--

PAGE NO.	COLM NO.	LINE NO.	NATIONAL STOCK NUMBER	REFERENCE NO.	FIGURE NO.	ITEM NO.	TOTAL NO. OF MAJOR ITEMS SUPPORTED	RECOMMENDED ACTION

PART III – REMARKS *(Any general remarks or recommendations, or suggestions for improvement of publications and blank forms. Additional blank sheets may be used if more space is needed.)*

TYPED NAME, GRADE OR TITLE Your Name	TELEPHONE EXCHANGE/AUTOVON, PLUS EXTENSION	SIGNATURE Your Signature
---	--	-----------------------------

RECOMMENDED CHANGES TO PUBLICATIONS AND BLANK FORMS						Use Part II (reverse) for Repair Parts and Special Tool Lists (RPSTL) and Supply Catalogs/Supply Manuals (SC/SM).	DATE
For use of this form, see AR 25-30; the proponent agency is ODISC4.							
TO: (Forward to proponent of publication or form) (Include ZIP Code) AMSTALC-LPIT / TECH PUBS, TACOM-RI 1 Rock Island Arsenal Rock Island, IL 61299-7630						FROM: (Activity and location) (Include ZIP Code)	
PART I - ALL PUBLICATIONS (EXCEPT RPSTL AND SC/SM) AND BLANK FORMS							
PUBLICATION/FORM NUMBER TM 9-2320-363-34-1						DATE 16 June 1992	TITLE Truck, Tractor, M915A2, M916A1, M916A2, M917A1, M917A1 W/MCS Volume 1 of 2
ITEM NO.	PAGE NO.	PARA-GRAPH	LINE NO. *	FIGURE NO.	TABLE NO.	RECOMMENDED CHANGES AND REASON (Provide exact wording of recommended changes, if possible).	
<i>*Reference to line numbers within the paragraph or subparagraph.</i>							
TYPED NAME, GRADE OR TITLE				TELEPHONE EXCHANGE/AUTOVON, PLUS EXTENSION		SIGNATURE	

TO: <i>(Forward direct to addressee listed in publication)</i> AMSTALC-LPIT / TECH PUBS, TACOM-RI 1 Rock Island Arsenal Rock Island, IL 61299-7630	FROM: <i>(Activity and location) (Include ZIP Code)</i>	DATE
--	--	-------------

PART II - REPAIR PARTS AND SPECIAL TOOL LISTS AND SUPPLY CATALOGS/SUPPLY MANUALS

PUBLICATION NUMBER TM 9-2320-363-34-1	DATE 16 June 1992	TITLE Truck, Tractor, M915A2, M916A1, M916A2, M917A1, M917A1 W/MCS Volume 1 of 2
--	----------------------	--

PAGE NO.	COLM NO.	LINE NO.	NATIONAL STOCK NUMBER	REFERENCE NO.	FIGURE NO.	ITEM NO.	TOTAL NO. OF MAJOR ITEMS SUPPORTED	RECOMMENDED ACTION

PART III - REMARKS *(Any general remarks or recommendations, or suggestions for improvement of publications and blank forms. Additional blank sheets may be used if more space is needed.)*

TYPED NAME, GRADE OR TITLE	TELEPHONE EXCHANGE/AUTOVON, PLUS EXTENSION	SIGNATURE
----------------------------	--	-----------

RECOMMENDED CHANGES TO PUBLICATIONS AND BLANK FORMS For use of this form, see AR 25-30; the proponent agency is ODISC4.						Use Part II (reverse) for Repair Parts and Special Tool Lists (RPSTL) and Supply Catalogs/Supply Manuals (SC/SM).	DATE
TO: (Forward to proponent of publication or form) (Include ZIP Code) AMSTALC-LPIT / TECH PUBS, TACOM-RI 1 Rock Island Arsenal Rock Island, IL 61299-7630						FROM: (Activity and location) (Include ZIP Code)	
PART I - ALL PUBLICATIONS (EXCEPT RPSTL AND SC/SM) AND BLANK FORMS							
PUBLICATION/FORM NUMBER TM 9-2320-363-34-1						DATE 16 June 1992	TITLE Truck, Tractor, M915A2, M916A1, M916A2, M917A1, M917A1 W/MCS Volume 1 of 2
ITEM NO.	PAGE NO.	PARA-GRAPH	LINE NO. *	FIGURE NO.	TABLE NO.	RECOMMENDED CHANGES AND REASON (Provide exact wording of recommended changes, if possible).	
<i>*Reference to line numbers within the paragraph or subparagraph.</i>							
TYPED NAME, GRADE OR TITLE				TELEPHONE EXCHANGE/AUTOVON, PLUS EXTENSION		SIGNATURE	

TO: <i>(Forward direct to addressee listed in publication)</i> AMSTALC-LPIT / TECH PUBS, TACOM-RI 1 Rock Island Arsenal Rock Island, IL 61299-7630	FROM: <i>(Activity and location) (Include ZIP Code)</i>	DATE
--	--	-------------

PART II - REPAIR PARTS AND SPECIAL TOOL LISTS AND SUPPLY CATALOGS/SUPPLY MANUALS

PUBLICATION NUMBER TM 9-2320-363-34-1	DATE 16 June 1992	TITLE Truck, Tractor, M915A2, M916A1, M916A2, M917A1, M917A1 W/MCS Volume 1 of 2
---	-----------------------------	---

PAGE NO.	COLM NO.	LINE NO.	NATIONAL STOCK NUMBER	REFERENCE NO.	FIGURE NO.	ITEM NO.	TOTAL NO. OF MAJOR ITEMS SUPPORTED	RECOMMENDED ACTION

PART III - REMARKS *(Any general remarks or recommendations, or suggestions for improvement of publications and blank forms. Additional blank sheets may be used if more space is needed.)*

--

TYPED NAME, GRADE OR TITLE	TELEPHONE EXCHANGE/AUTOVON, PLUS EXTENSION	SIGNATURE
-----------------------------------	---	------------------

THE METRIC SYSTEM AND EQUIVALENTS

<p>Linear Measure</p> <p>1 Centimeter = 10 Millimeters = 0.01 Meters = 0.3937 Inches 1 Meter = 100 Centimeters = 1000 Millimeters = 39.37 Inches 1 Kilometer = 1000 Meters = 0.621 Miles</p> <p>Weights</p> <p>1 Gram = 0.001 Kilograms = 1000 Milligrams = 0.035 Ounces 1 Kilogram = 1000 Grams = 2.2 Pounds 1 Metric Ton = 1000 Kilograms = 1 Megagram = 1.1 Short Tons</p> <p>Liquid Measure</p> <p>1 Milliliter = 0.001 Liters = 0.0338 Fluid Ounces 1 Liter = 1000 Milliliters = 33.82 Fluid Ounces</p>	<p>Square Measure</p> <p>1 Sq Centimeter = 100 Sq Millimeters = 0.155 Sq Inches 1 Sq Meter = 10,000 Sq Centimeters = 10.76 Sq Feet 1 Sq Kilometer = 1,000,000 Sq Meters = 0.386 Sq Miles</p> <p>Cubic Measure</p> <p>1 Cu Centimeter = 1,000 Cu Millimeters = 0.06 Cu Inches 1 Cu Meter = 1,000,000 Cu Centimeters = 35.31 Cu Feet</p> <p>Temperature</p> <p>$5/9 (^{\circ}\text{F} - 32) = ^{\circ}\text{C}$ 212° Fahrenheit is equivalent to 100° Celsius 90° Fahrenheit is equivalent to 32.2° Celsius 32° Fahrenheit is equivalent to 0° Celsius $9/5 \text{ C}^{\circ} + 32 = \text{F}^{\circ}$</p>
--	--

APPROXIMATE CONVERSION FACTORS

To Change	To	Multiply By
Inches	Centimeters	2.540
Feet	Meters	0.305
Yards	Meters	0.914
Miles	Kilometers	1.609
Sq Inches	Sq Centimeters	6.451
Sq Feet	Sq Meters	0.093
Sq Yards	Sq Meters	0.836
Sq Miles	Sq Kilometers	2.590
Acres	Sq Hectometers	0.405
Cubic Feet	Cubic Meters	0.028
Cubic Yards	Cubic Meters	0.765
Fluid Ounces	Milliliters	29.573
Pints	Liters	0.473
Quarts	Liters	0.946
Gallons	Liters	3.785
Ounces	Grams	28.349
Pounds	Kilograms	0.454
Short Tons	Metric Tons	0.907
Pound-Feet	Newton-Meters	1.356
Pounds per Sq Inch	Kilopascals	6.895
Miles per Gallon	Kilometers per Liter	0.425
Miles per Hour	Kilometers per Hour	1.609

To Change	To	Multiply By
Centimeters	Inches	0.394
Meters	Feet	3.280
Meters	Yards	1.094
Kilometers	Miles	0.621
Sq Centimeters	Sq Inches	0.155
Sq Meters	Sq Feet	10.764
Sq Meters	Sq Yards	1.196
Sq Kilometers	Sq Miles	0.386
Sq Hectometers	Acres	2.471
Cubic Meters	Cubic Feet	35.315
Cubic Meters	Cubic Yards	1.308
Milliliters	Fluid Ounces	0.034
Liters	Pints	2.113
Liters	Quarts	1.057
Liters	Gallons	0.264
Grams	Ounces	0.035
Kilograms	Pounds	2.205
Metric Tons	Short Tons	1.102
Newton-Meters	Pound-Feet	0.738
Kilopascals	Pounds per Sq Inch	0.145
Kilometers per Liter	Miles per Gallon	2.354
Kilometers per Hour	Miles per Hour	0.621

